

Geared servo motors

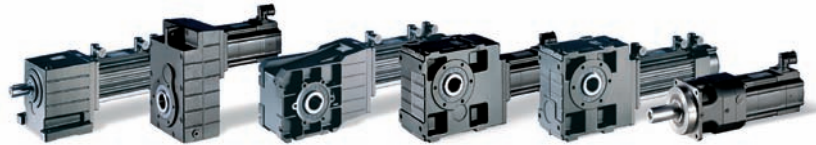

G-motion servo MC



Our commitment to you

If you are looking for effective and easy solutions for the implementation of your machine and drive concepts or want to optimise existing concepts and cut your costs, Lenze is your ideal partner.

We have a 60 years experience at the cutting edge of drive and automation technology.



Drive and automation technology set in motion by Lenze – for example in logistics centres, in the textile and printing industry, in the automotive industry or as the driving force behind robots.

Lenze | about us

We can offer you automation solutions, including control, visualisation and drive technology, from one source. Our drive systems will improve the performance of your machines. From project planning to commissioning, we have the know-how. Our international sales and service network can provide you with expert help and advice at any time.

Cut your process costs and increase your ability to compete. Let us analyse your drive technology tasks and support you with made-to-measure solutions.

We can take an integrated approach to projects thanks to the scalability of our products and the scope of the overall portfolio. We can get the best from your machines and systems.

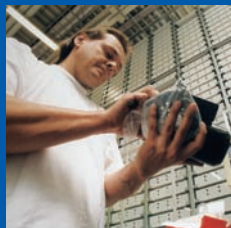

At your side all over the world – with thorough and professional support from our motivated team.

System overview | G-motion servo

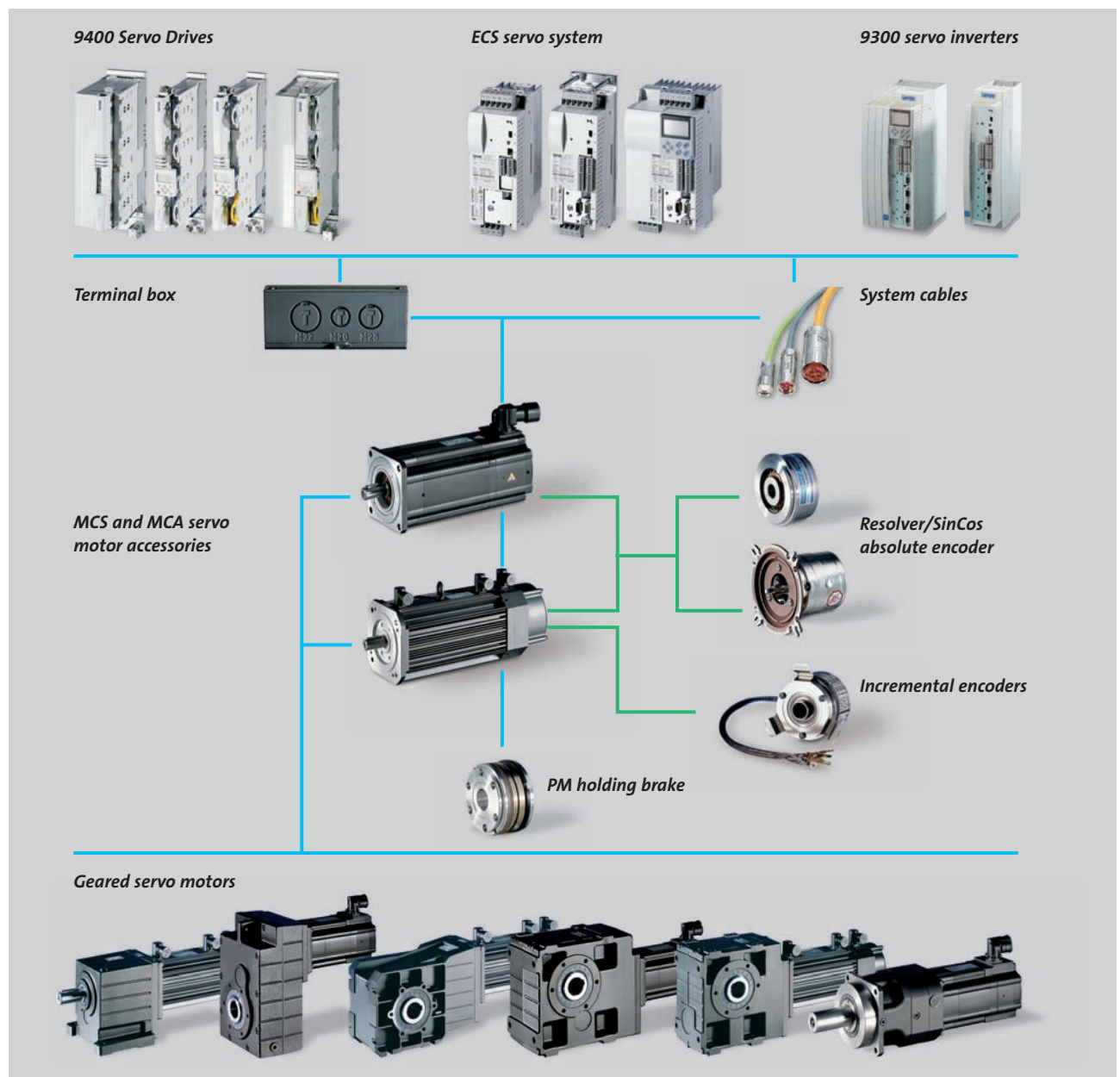

Further catalogues

This catalogue describes geared servo motors in the G-motion Servo MC series. Further components in the above system overview may be found in the following catalogues:

Components

9400 Servo Drives
 ECS servo system
 9300 servo inverter
 MCS/MCA servo motors
 and accessories

Catalogue

→ 9400 Servo Drives
 → ECS servo system
 → 9300 servo inverter
 → Servo motors

Overview | G-motion servo MC

Contents _____ 6



General information _____ 14

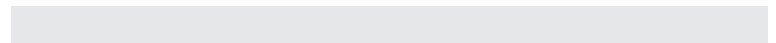

Drive dimensioning _____ 33

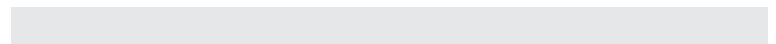

GST helical gearbox _____ 65

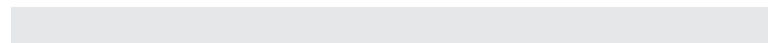

GFL shaft-mounted helical gearbox _____ 273

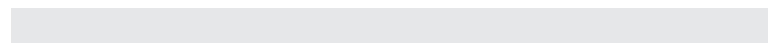

GPA planetary gearbox _____ 451

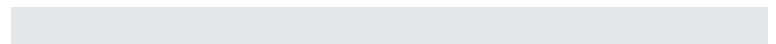

GKR bevel gearbox _____ 485

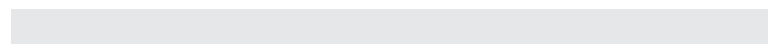

GKS helical-bevel gearbox _____ 539

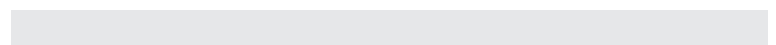

GSS helical-worm gearbox _____ 705

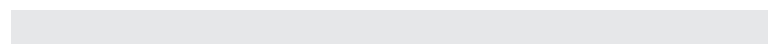

Servo motors _____ 801

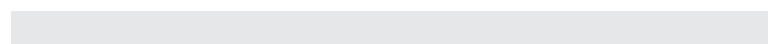

Lenze worldwide _____ 812

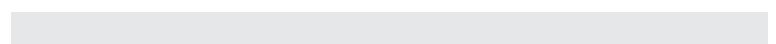

Contents | G-motion servo MC

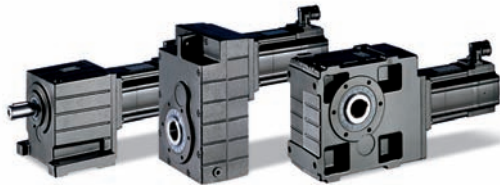

General

Product keys, mounting positions, position of the system blocks, versions, options and order details checklist >

as an insert in the front of the catalogue or _____	14
Product information _____	28
List of abbreviations _____	29
Definitions _____	31
Notes on ordering _____	32

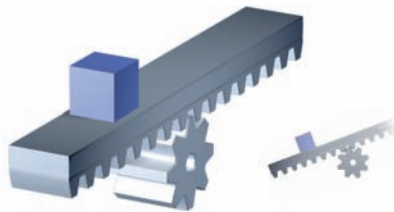

Drive dimensioning

Our service _____	33
Aim of dimensioning _____	34
Scope _____	36
Operating modes _____	37
Dimensioning of geared servo motors _____	38
Dimensioning for operating mode S1 _____	38
Dimensioning for operating modes S2, S3 and S6 _____	41
Dimensioning for profiles _____	45
Maximum gearbox input speeds _____	50
Recommended motors for operating modes S1 and S6 _____	50
Speed correction factors _____	51
Additional radial force factors/Application factors _____	52
Application factors/efficiencies _____	53
General data _____	61
Ventilation _____	63
Lubricants _____	64

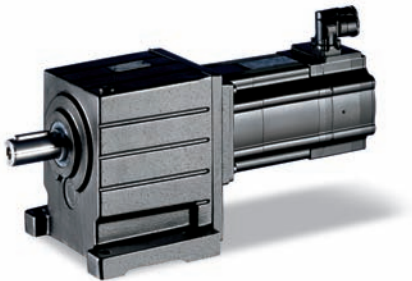

GST helical gearbox

GST [N]	Permissible radial and axial forces on the output _____	65
GST [']	Output backlash _____	69
GST [⊗]	Ventilation Position of ventilation, sealing elements and oil control _____	71
	Compensation reservoir for mounting position C _____	74
GST [kg]	Weights _____	75
GST [i]	Ratios _____	82
GST [Nm]	Selection tables	
GST□□-□S (MCS)	Synchronous geared servo motors ___	92
GST□□-□A (MCA)	Asynchronous geared servo motors _	176
GST [mm]	Dimensions	
GST□□-1S (MCS)	Synchronous geared servo motors 1-stage _____	234
GST□□-2S (MCS)	Synchronous geared servo motors 2-stage _____	240
GST□□-3S (MCS)	Synchronous geared servo motors 3-stage _____	246
GST□□-1A (MCA)	Asynchronous geared servo motors 1-stage _____	252
GST□□-2A (MCA)	Asynchronous geared servo motors 2-stage _____	258
GST□□-3A (MCA)	Asynchronous geared servo motors 3-stage _____	264
GST & [mm]	Further gearbox dimensions	
	VAR output side _____	270
	VAL output side _____	271

>>>

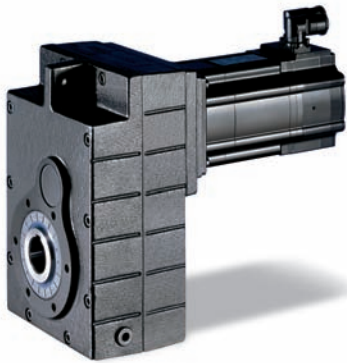

GFL shaft-mounted helical gearbox

GFL [N]	Permissible radial and axial forces on the output _____	273
GFL [']	Output backlash _____	276
GFL [⊗]	Ventilation Position of the ventilation, sealing elements and oil control _____	277
	Compensation reservoir for mounting position C _____	279
GFL [kg]	Weights _____	280
GFL [i]	Ratios _____	283
GFL [Nm]	Selection tables	
GFL□□-□S (MCS)	Synchronous geared servo motors ___	290
GFL□□-□A (MCA)	Asynchronous geared servo motors _	362
GFL [mm]	Dimensions	
GFL□□-2S (MCS)	Synchronous geared servo motors 2-stage _____	412
GFL□□-3S (MCS)	Synchronous geared servo motors 3-stage _____	420
GFL□□-2A (MCA)	Asynchronous geared servo motors 2-stage _____	428
GFL□□-3A (MCA)	Asynchronous geared servo motors 3-stage _____	436
GFL & [mm]	Further gearbox dimensions	
	Hollow shaft with shrink disc _____	444
	Foot mounting _____	446
	Rubber buffer set _____	448
	Mounting set for hollow shaft circlip _____	449
	Proposed design for auxiliary tools _	449



GPA planetary gearbox

GPA [N]	Permissible radial and axial forces at the output _____	451
GPA [']	Output backlash _____ Torsional stiffness _____	452
GPA [kg]	Weights _____	453
GPA [Nm]	Selection tables	
GPA□□-□S (MCS)	Synchronous geared servo motors	456
GPA□□-□A (MCA)	Asynchronous geared servo motors	467
GPA [mm]	Dimensions	
GPA□□-1S (MCS)	Synchronous geared servo motors 1-stage _____	476
GPA□□-2S (MCS)	Synchronous geared servo motors 2-stage _____	478
GPA□□-1A (MCA)	Asynchronous geared servo motors 1-stage _____	480
GPA□□-2A (MCA)	Asynchronous geared servo motors 2-stage _____	482

>>>

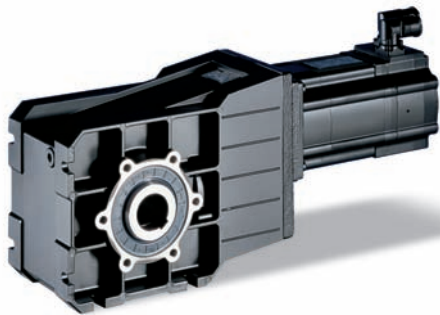

GKR bevel gearbox

GKR [N]	Permissible radial and axial forces at the output _____	485
GKR [']	Output backlash _____	488
GKS [⊗]	Position of ventilation _____	489
GKR [kg]	Weights _____	490
GKR [i]	Ratios _____	492
GKR [Nm]	Selection tables	
GKR□□-2S (MCS)	Synchronous geared servo motors _	495
GKR□□-2A (MCA)	Asynchronous geared servo motors _	510
GKR [mm]	Dimensions	
GKR□□-2S (MCS)	Synchronous geared servo motors	
	2-stage _____	516
GKR□□-2A (MCA)	Asynchronous geared servo motors	
	2-stage _____	524
GKR & [mm]	Further gearbox dimensions	
	Hollow shaft with shrink disc _____	532
	Hoseproof hollow shaft cover _____	533
	Gearbox with 2nd output shaft end _	533
	Rubber buffer for torque plate _____	534
	Torque plate at threaded hole circle _	535
	Torque plate at casing foot _____	537
	Mounting set for hollow shaft circlip	537
	Proposed design for auxiliary tools _	537

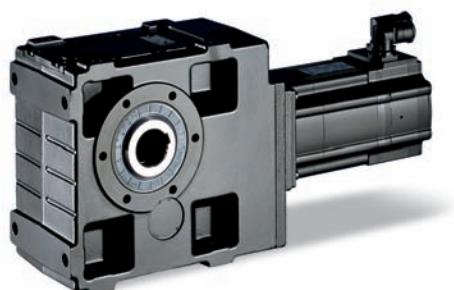

GKS helical-bevel gearbox

GKS [N]	Permissible radial and axial forces at the output _____	539
GKS [']	Output backlash _____	542
GKS [⊗]	Ventilation Position of ventilation, sealing elements and oil control _____	543
	Compensation reservoir for mounting position C _____	545
GKS [kg]	Weights _____	546
GKS [i]	Ratios _____	549
GKS [Nm]	Selection tables	
GKS□□-□S (MCS)	Synchronous geared servo motors	558
GKS□□-□A (MCA)	Asynchronous geared servo motors	620
GKS [mm]	Dimensions	
GKS□□-3S (MCS)	Synchronous geared servo motors 3-stage _____	666
GKS□□-4S (MCS)	Synchronous geared servo motors 4-stage _____	674
GKS□□-3A (MCA)	Asynchronous geared servo motors 3-stage _____	682
GKS□□-4A (MCA)	Asynchronous geared servo motors 4-stage _____	690
GKS & [mm]	Further gearbox dimensions	
	Hollow shaft with shrink disc _____	698
	Hoseproof hollow shaft cover _____	699
	Gearbox with 2nd output shaft end	700
	Torque plate at threaded pitch circle	701
	Torque plate at casing foot _____	702
	Mounting set for hollow shaft circlip	703
	Proposed design for auxiliary tools	703

>>>

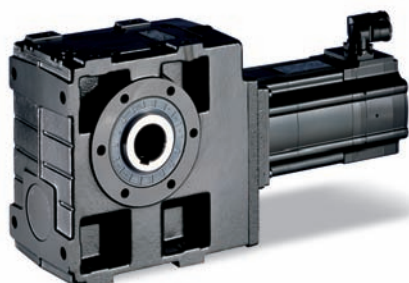

GSS helical-worm gearbox

GSS [N]	Permissible radial and axial forces at the output _____	705
GSS [⊗]	Ventilation Position of ventilation, sealing elements and oil control _____	707
GSS [kg]	Weights _____	709
GSS [i]	Ratios _____	712
GSS [Nm]	Selection tables	
GSS□□-□S (MCS)	Synchronous geared servo motors _	716
GSS□□-□A (MCA)	Asynchronous geared servo motors _	746
GSS [mm]	Dimensions	
GSS□□-2S (MCS)	Synchronous geared servo motors 2-stage _____	764
GSS□□-3S (MCS)	Synchronous geared servo motors 3-stage _____	772
GSS□□-2A (MCA)	Asynchronous geared servo motors 2-stage _____	780
GSS□□-3A (MCA)	Asynchronous geared servo motors 3-stage _____	788
GSS & [mm]	Further gearbox dimensions	
	Hollow shaft with shrink disc _____	796
	Gearbox with 2nd output shaft end _____	797
	Hoseproof hollow shaft cover _____	797
	Torque plate at the threaded pitch circle _____	798
	Torque plate at casing foot _____	799
	Mounting set for hollow shaft circlip _____	800
	Proposed design for auxiliary tools _	800



Servo motors

MCS & [mm]

Further dimensions

MCS synchronous servo motors with
encoder/resolver

SRS / SRM / ECN / EQN / EQI / C20 _____ 801

Terminal box for motor connection _____ 802

MCA & [mm]

Further dimensions

MCA asynchronous servo motors with
encoder/resolver

SRS / SRM /

ECN / EQN / EQI / S20 / T20 / CDD _____ 803

Connectors for motor connection _____ 804

Terminal box for motor connection _____ 808

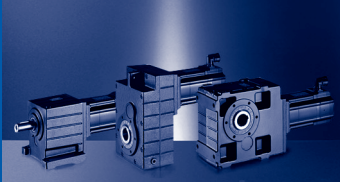

General information

Helical gearbox product key

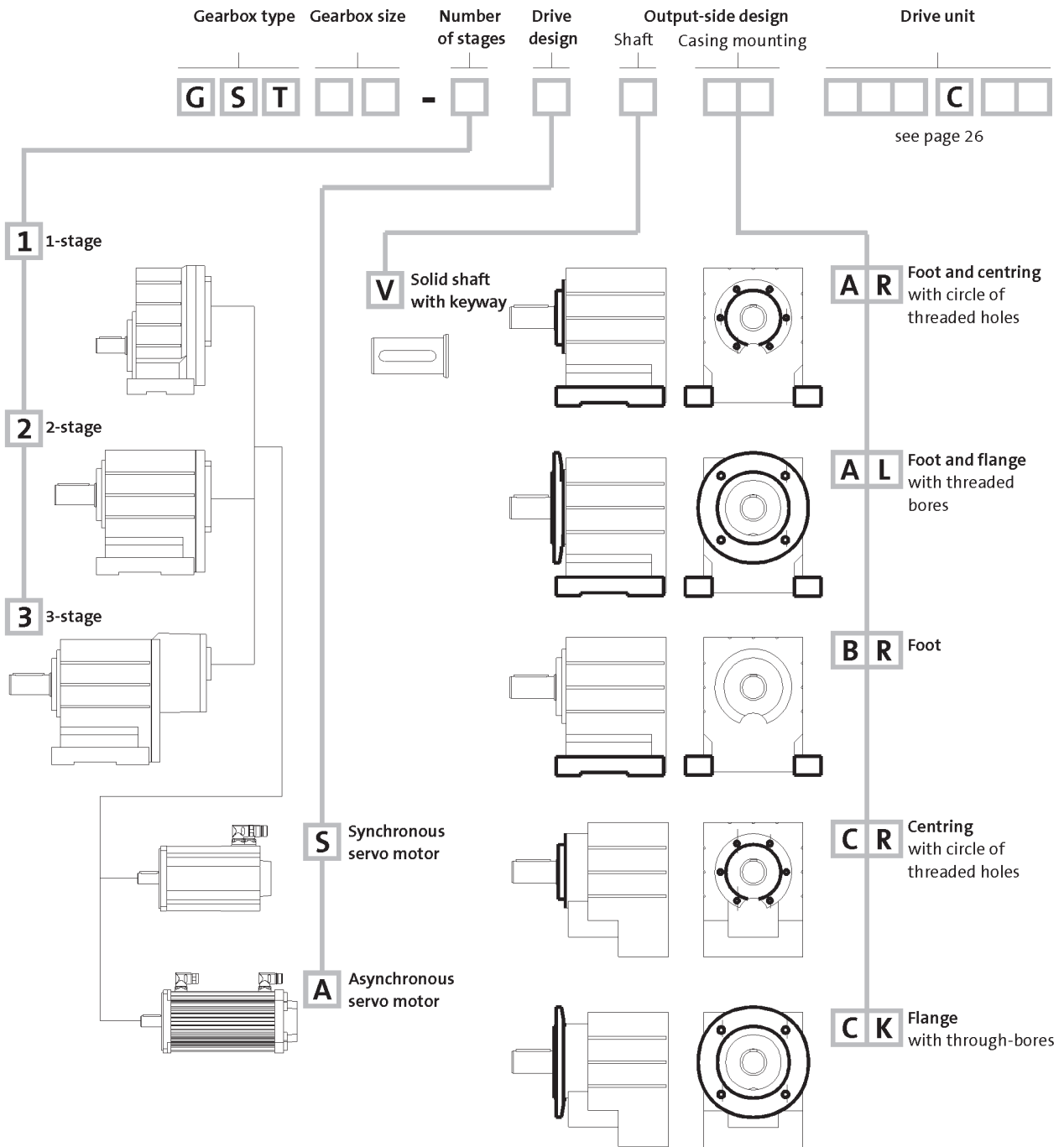

	Output-side design		
	V	K	L
	d x l [mm]	Øa2 [mm]	Øa2 [mm]
GST03-2	14x28	120/140/160	
	20x40	120/140/160	
GST04-1	16x32	120/140/160	
GST04-2	20x40	120/140/160	120/140
GST05-1	20x40	120/140/160/200	
GST05-2/3	25x50	120/140/160/200	120/140/160
GST06-1	25x50	160/200	

	Output side design		
	V	K	L
	d x l [mm]	Øa2 [mm]	Øa2 [mm]
GST06-2/3	30x60	160/200	160/200
GST07-1	30x60	200/250	
GST07-2/3	40x80	200/250	200/250
GST09-1	40x80	250/300	
GST09-2/3	50x100	250/300	250/300
GST11-2/3	60x120	300/350	300/350
GST14-2/3	80x160	350/400	350/400

General information

Helical gearbox product key

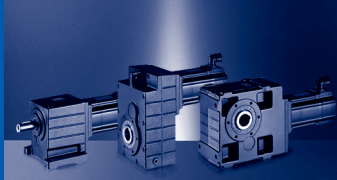

Mounting position (A - F) and position of system blocks (1 - 6)

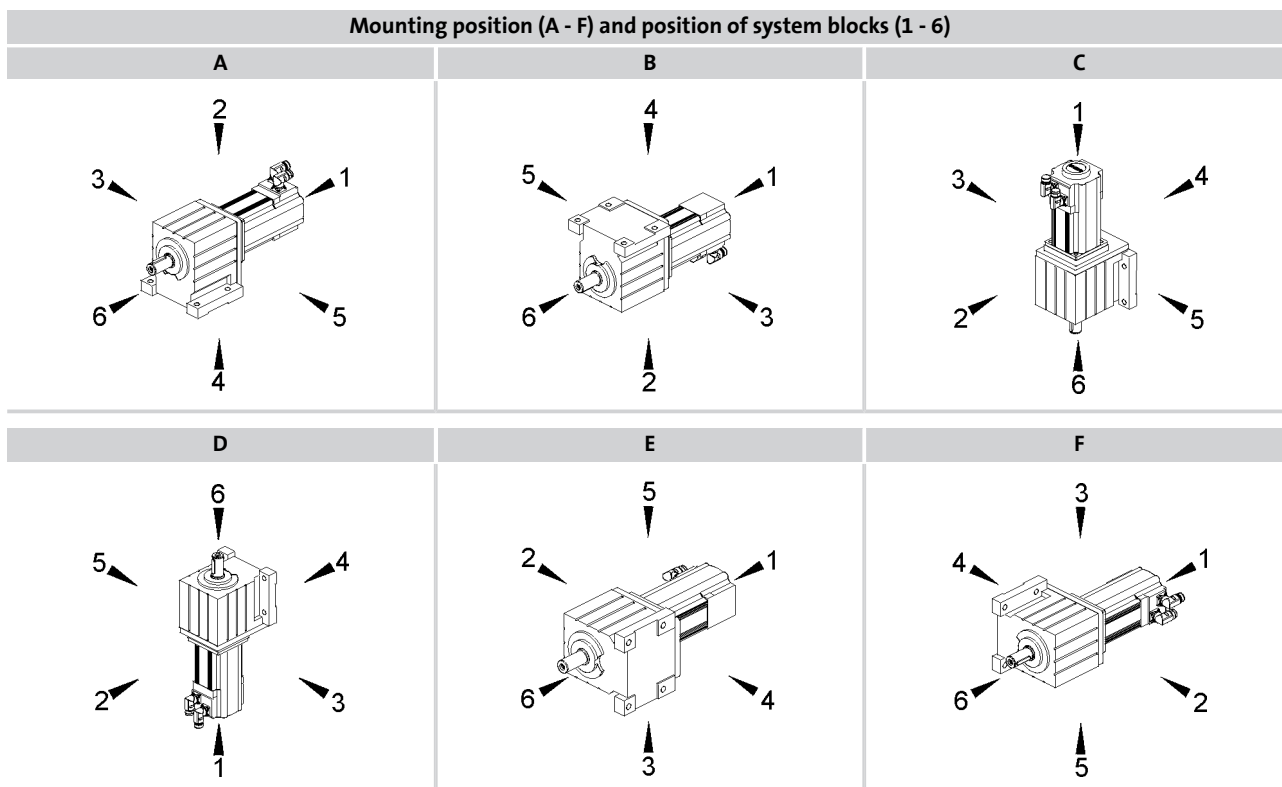

Connector/terminal box: 2, 3, 4, 5

Basic versions	
Colour	Grey primer RAL 9005 (jet black matt) paint
Lubricant	Synthetic CLP HC 320
Ventilation	Oil control plugs for GST05 - 14 Breather elements for GST06 - 14
Options	
Colour	Special paint in accordance with RAL
Lubricant	CLP HC 220 USDA H1
Ventilation	Breather elements for GST05 Compensation reservoir for GST09...14 in mounting position C
Bearing	Reinforced driven shaft
Shaft sealing rings	Driven shaft: Viton

Ordering details checklist	
Product key	GST...
Ratio	$i = \dots$
Shaft diameter	$d = \dots$ [mm]
Flange diameter	$a_2 = \dots$ [mm]
Mounting position	A, B, C, D, E, F
Position of system blocks	Connector/terminal box: 2, 3, 4, 5
Colour	
Options	

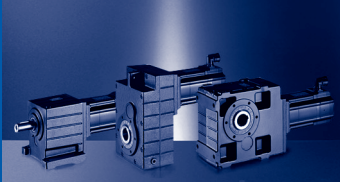

General information

Shaft-mounted helical gearbox product key

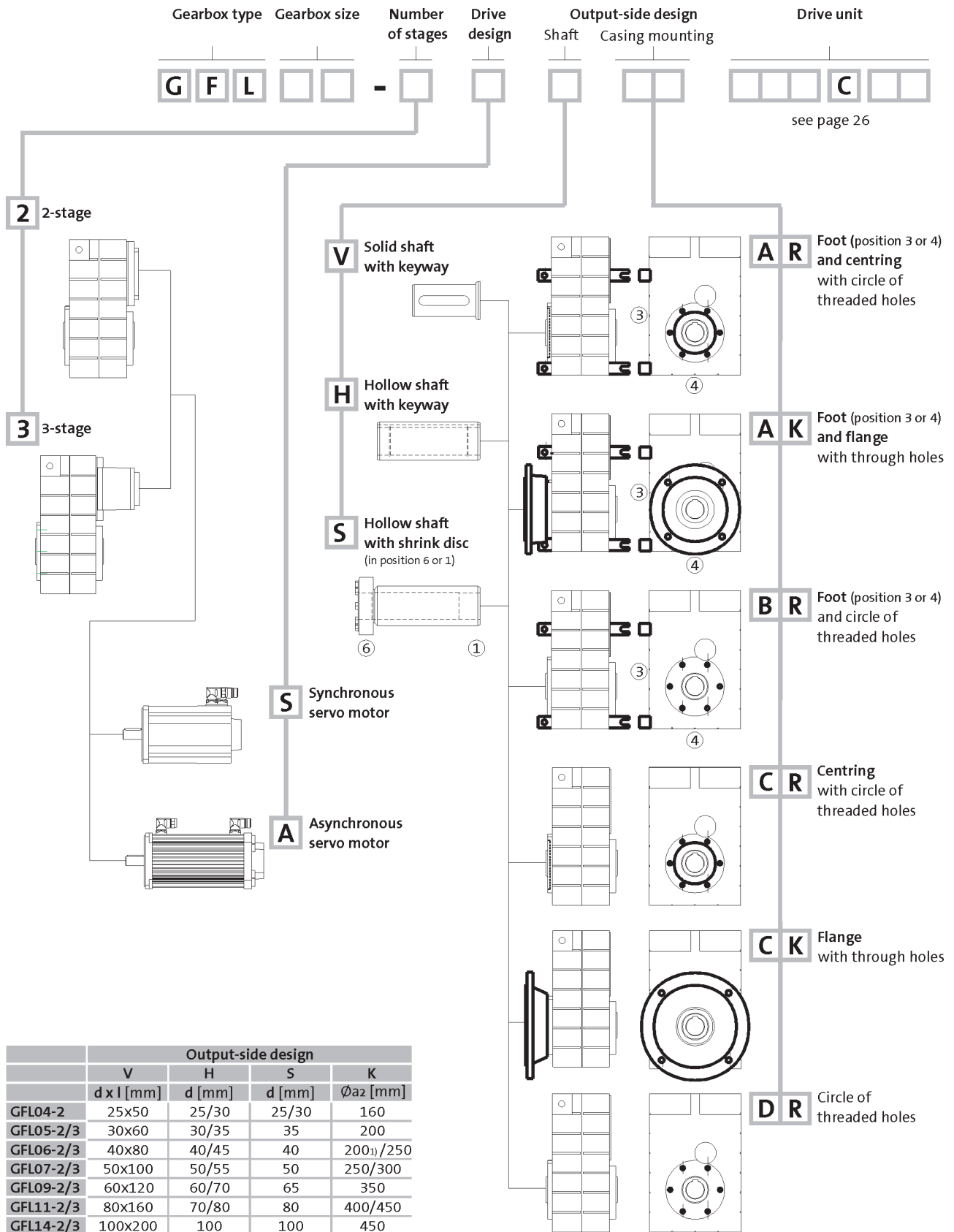

1) Only with output-side design H and S

General information

Shaft-mounted helical gearbox product key

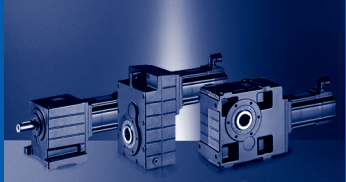

Mounting position (A - F) and position of system blocks (1 - 6)

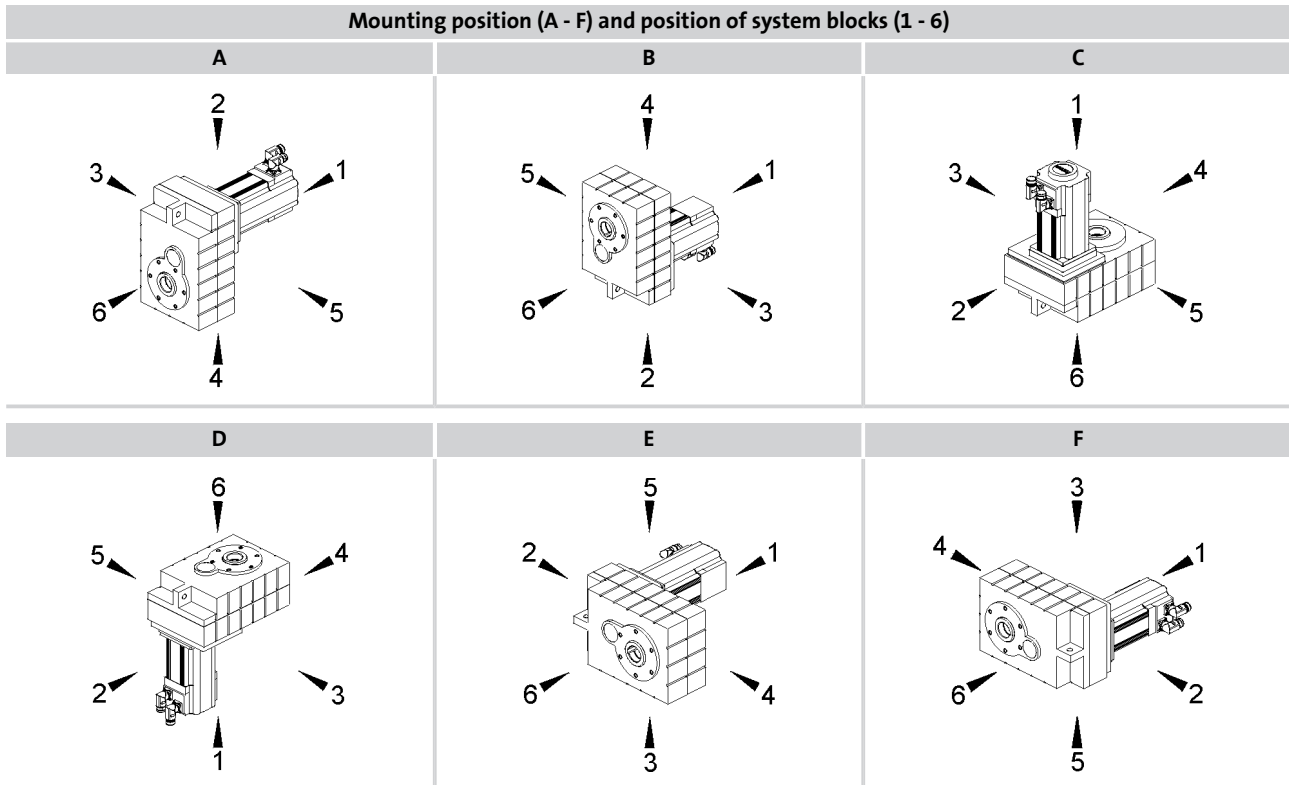

Solid shaft: 6
 Hollow shaft: 0
 Hollow shaft with shrink disc: 1, 6

Without foot: 0
 Foot: 3, 4
 Connector/terminal box: 2, 3, 4, 5

Basic versions	
Colour	Grey primer RAL 9005 (jet black matt) paint
Lubricant	Synthetic CLP HC 320
Ventilation	Oil control plugs for GFL05 - 14 Breather elements for GFL06 - 14
Options	
Colour	Special paint in accordance with RAL
Lubricant	CLP HC 220 USDA H1
Ventilation	Breather elements for GFL05 Compensation reservoir for GFL09...14 in mounting position C
Shaft sealing rings	Driven shaft: Viton
Accessories	Rubber buffer for torque plate Cover shrink disc Hollow shaft circlip assembly kit

Ordering details checklist	
Product key	GFL...
Ratio	$i = \dots$
Shaft diameter	$d = \dots$ [mm]
Flange diameter	$a_2 = \dots$ [mm]
Mounting position	A, B, C, D, E, F
Position of system blocks	Shaft: 0, 1, 6 Foot: 0, 3, 4 Connector/terminal box: 2, 3, 4, 5
Colour	
Options	

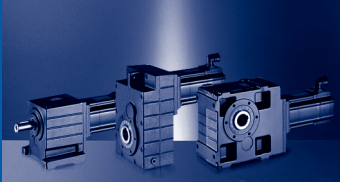

General information

Bevel gearbox product key

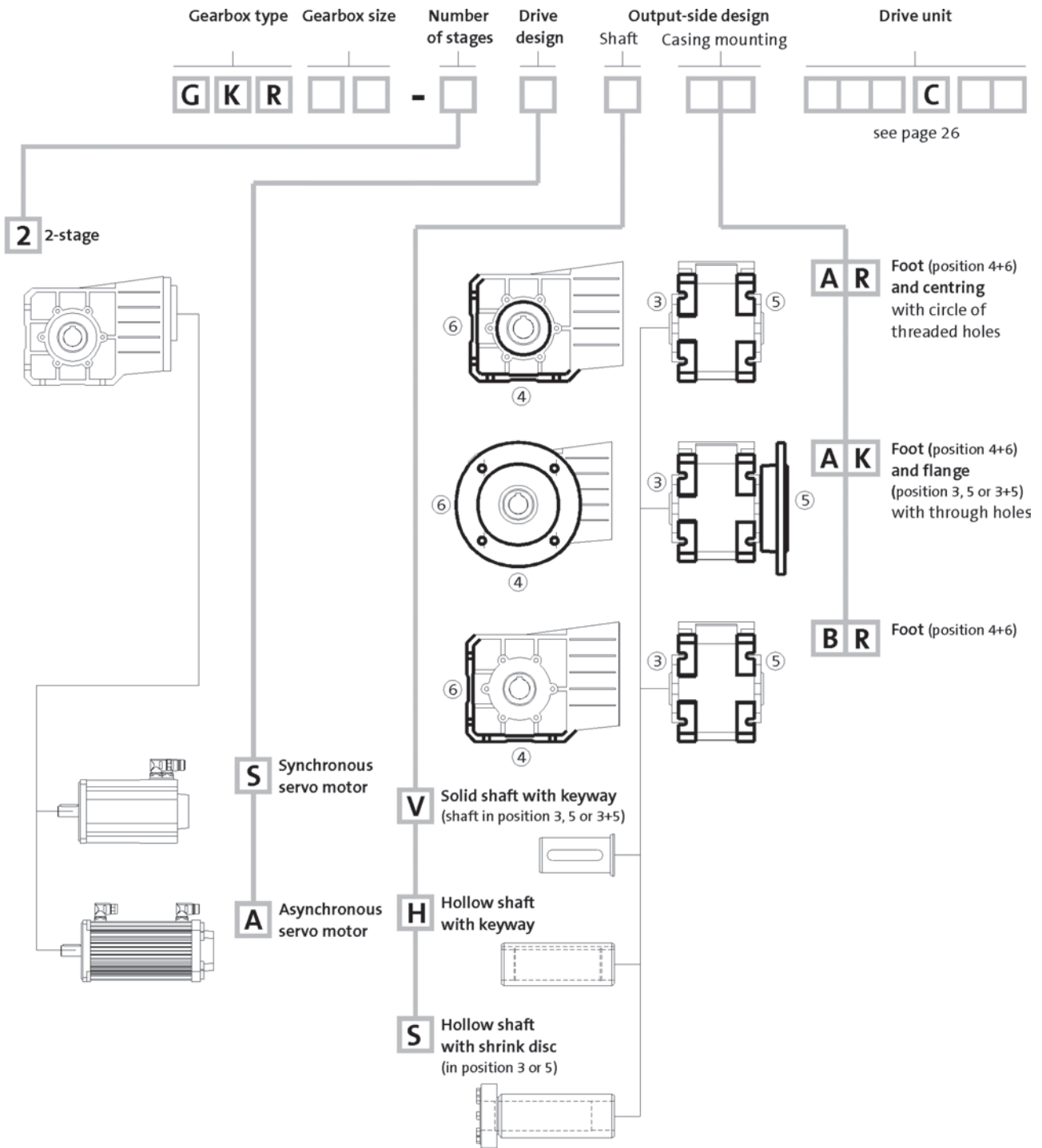

	Output-side design			
	V	H	S	K
	d x l [mm]	d [mm]	d [mm]	Øa2 [mm]
GKR03-2	20x40	18/20	20	110/120
GKR04-2	20x40	20/25	20	120/160
GKR05-2	30x60	30/35	30/35	160/200
GKR06-2	35x70	40/45	40	200/250

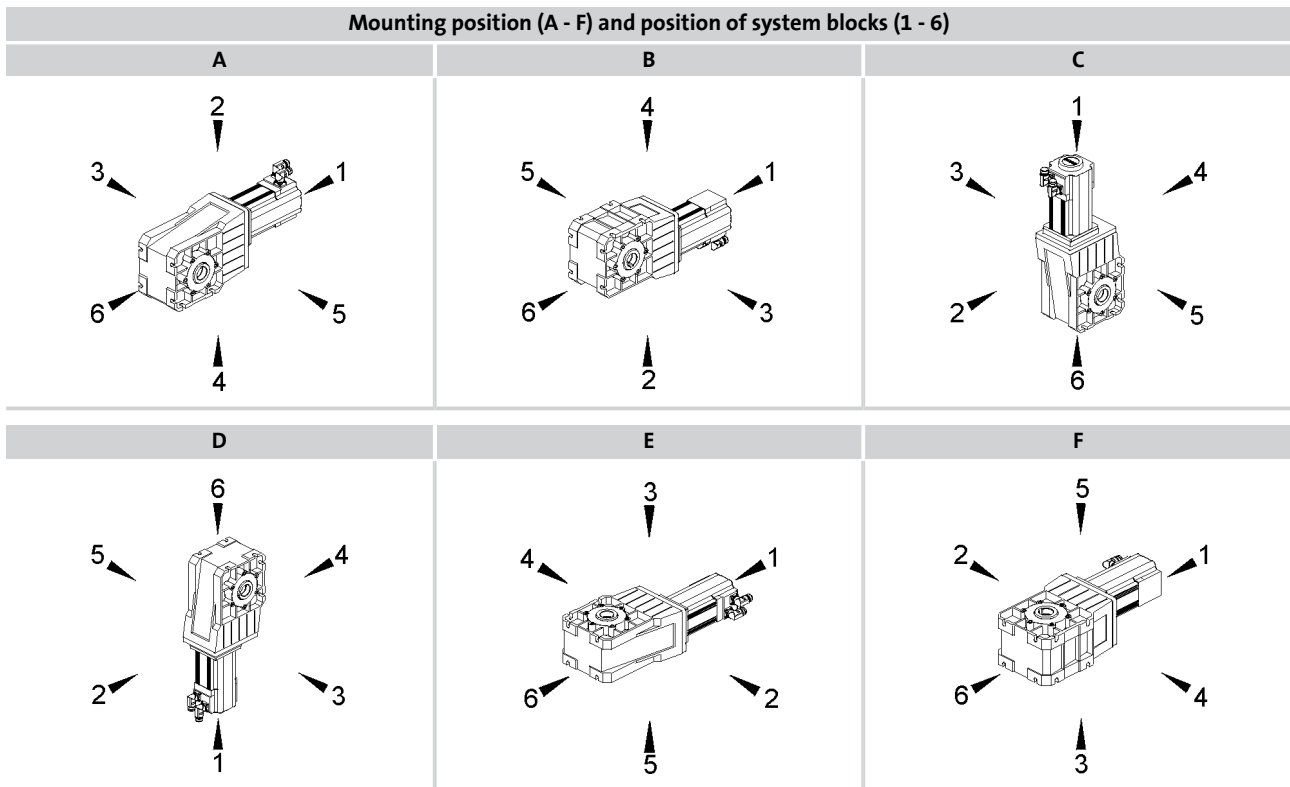
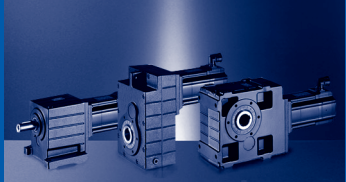

Solid shaft: 3, 5, 8 (3+5)
Hollow shaft: 0
Hollow shaft with shrink disc: 3, 5

Without flange: 0
Flange: 3, 5, 8 (3+5)
Connector/terminal box: 2, 3, 4, 5

Basic versions	
Colour	Grey primer RAL 9005 (jet black matt) paint
Lubricant	Synthetic CLP HC 320
Ventilation	Breather elements for GKR06
Options	
Colour	Special paint in accordance with RAL
Lubricant	CLP HC 220 USDA H1
Shaft sealing rings	Driven shaft: Viton
Accessories	Rubber buffer for torque plate (GKR03/04 only) Threaded hole circle torque plate Torque plate for casing foot (GKR05/06 only) 2nd output shaft end Cover shrink disc Hoseproof hollow shaft cover Hollow shaft circlip assembly kit

Ordering details checklist	
Product key	GKR...
Ratio	$i = \dots$
Shaft diameter	$d = \dots$ [mm]
Flange diameter	$a_2 = \dots$ [mm]
Mounting position	A, B, C, D, E, F
Position of system blocks	Shaft: 3, 5, 8 Flange: 0, 3, 5, 8 Connector/terminal box: 2, 3, 4, 5
Colour	
Options	

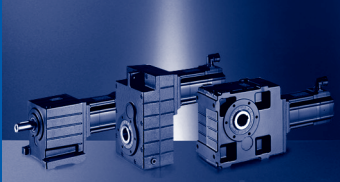

General information

Helical-bevel gearbox product key

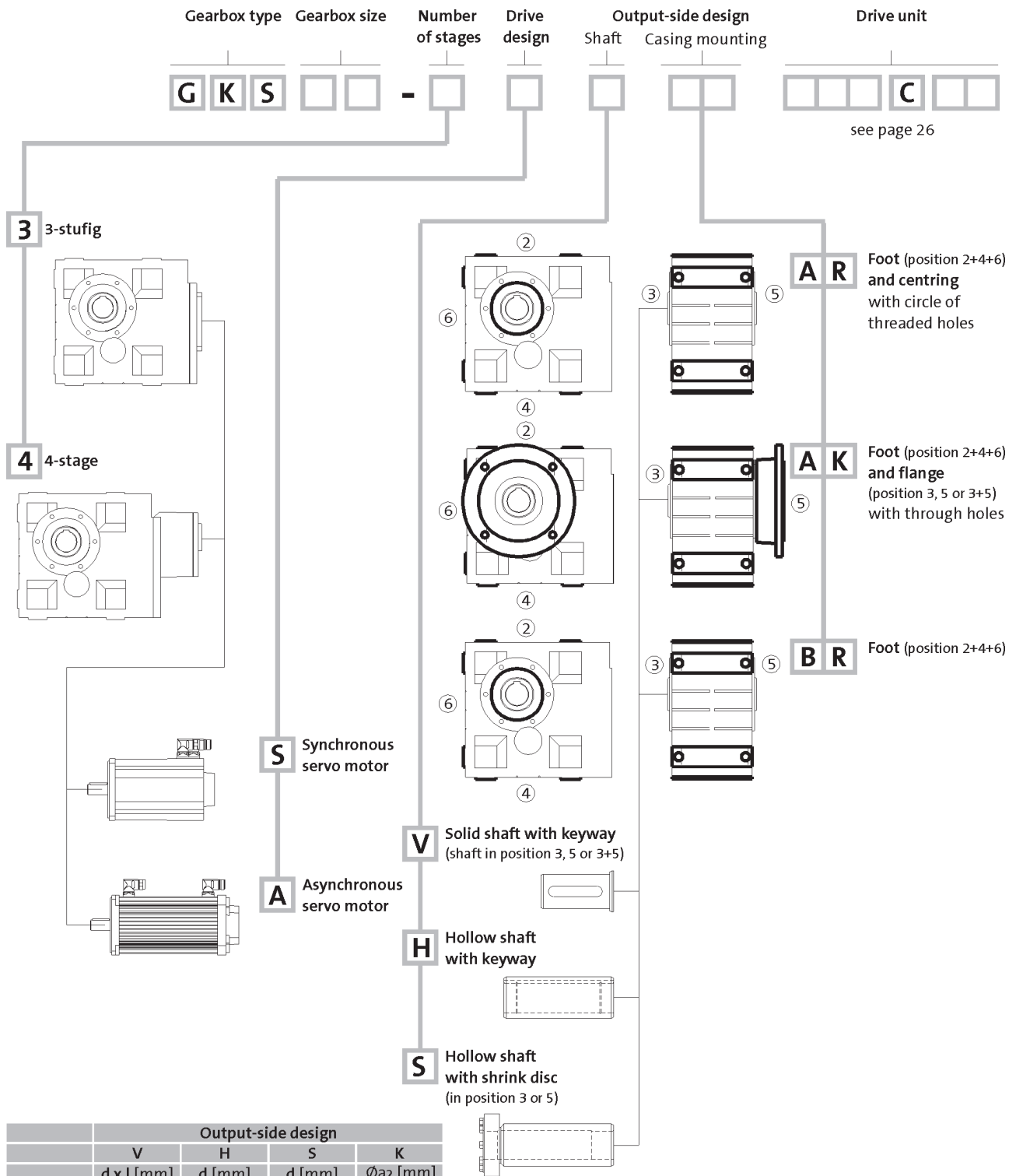

1) Only with output-side design H and S

General information

Helical-bevel gearbox product key

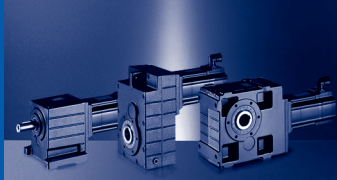

Mounting position (A - F) and position of system blocks (1 - 6)

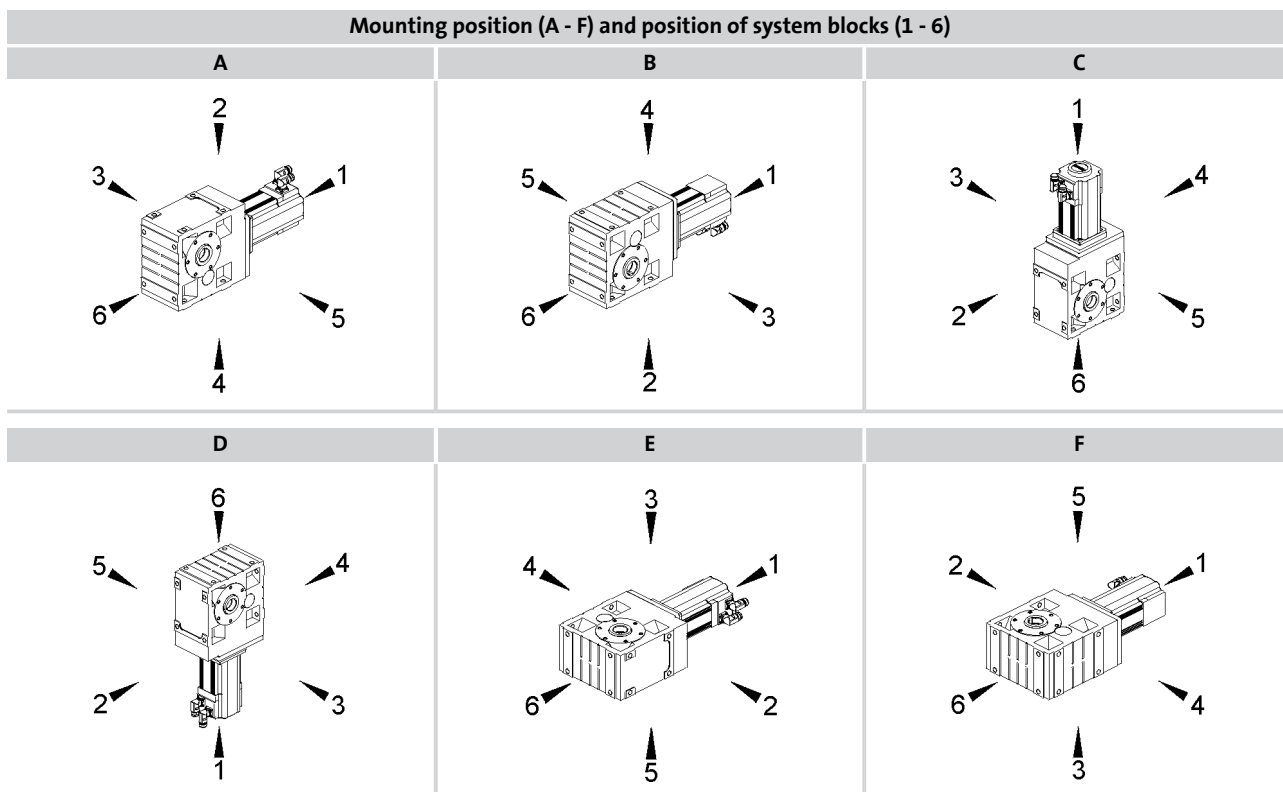

Solid shaft: 3, 5, 8 (3+5)
 Hollow shaft: 0
 Hollow shaft with shrink disc: 3, 5

Without flange: 0
 Flange: 3, 5, 8 (3+5)
 Connector/terminal box: 2, 3, 4, 5

Basic versions	
Colour	Grey primer RAL 9005 (jet black matt) paint
Lubricant	Synthetic CLP HC 320
Ventilation	Oil control plugs for GKS05 - 14 Breather elements for GKS06 - 14
Options	
Colour	Special paint in accordance with RAL
Lubricant	CLP HC 220 USDA H1
Ventilation	Breather elements for GKS05 Compensation reservoir for GKS09...14 in mounting position C
Shaft sealing rings	Driven shaft: Viton
Accessories	Threaded hole circle torque plate Casing foot torque plate 2nd output shaft end Cover shrink disc Hoseproof hollow shaft cover Hollow shaft circlip assembly kit

Ordering details checklist	
Product key	GKS...
Ratio	$i = \dots$
Shaft diameter	$d = \dots$ [mm]
Flange diameter	$a_2 = \dots$ [mm]
Mounting position	A, B, C, D, E, F
Position of system blocks	Shaft: 3, 5, 8 Flange: 0, 3, 5, 8 Connector/terminal box: 2, 3, 4, 5
Colour	
Options	

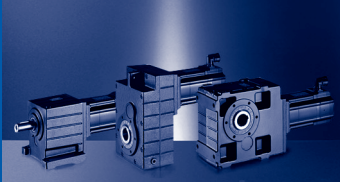

General information

Helical-worm gearbox product key

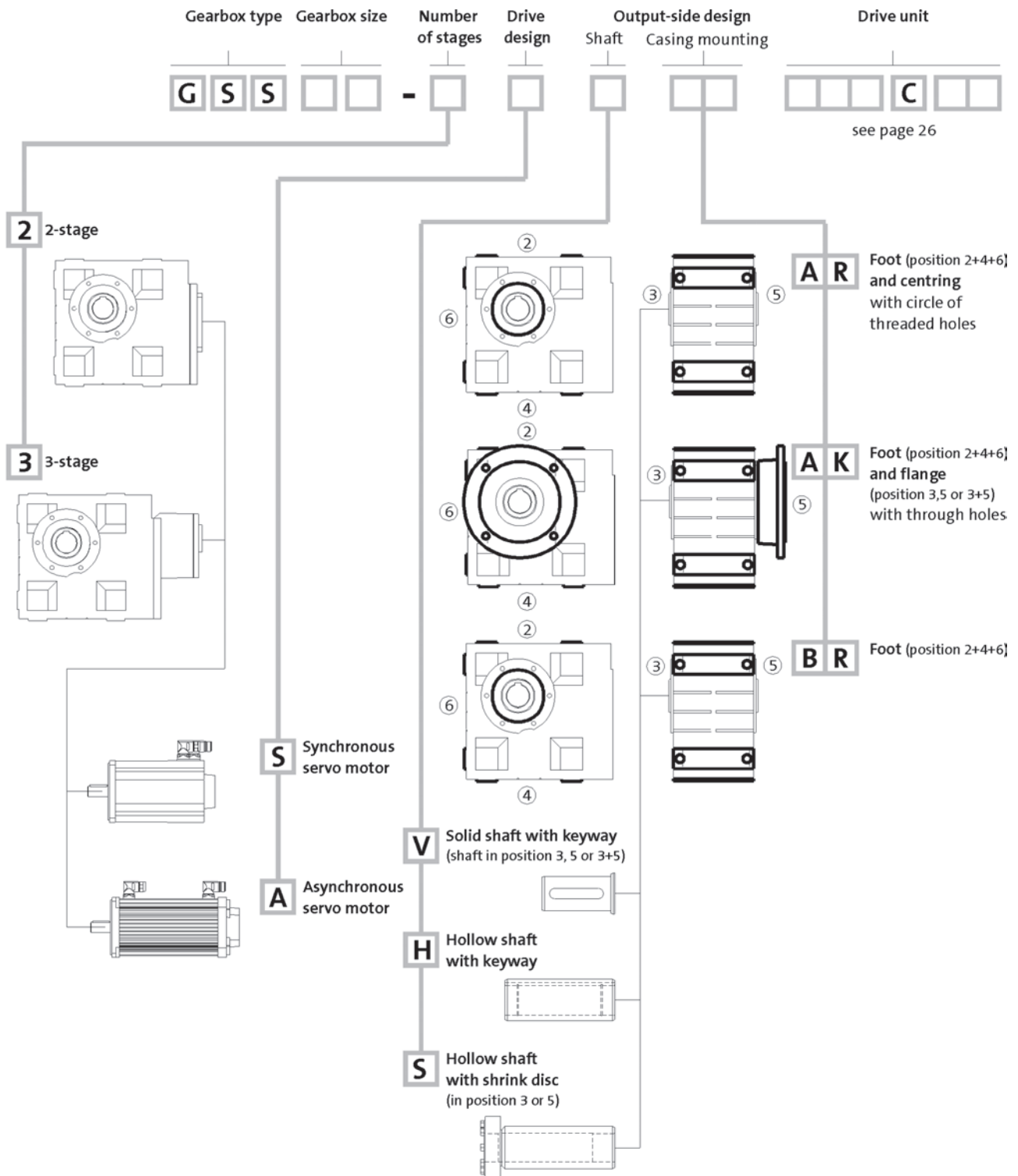

	Output-side design			
	V	H	S	K
	d x l [mm]	d [mm]	d [mm]	Øa2 [mm]
GSS04-2	25x50	25/30	25/30	160
GSS05-2/3	30x60	30/35	35	200
GSS06-2/3	40x80	40/45	40	200 ₁ /250
GSS07-2/3	50x100	50/55	50	250/300

1) Only with output-side design H and S

General information

Helical-worm gearbox product key

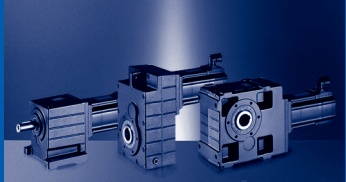

Mounting position (A - F) and position of system blocks (1 - 6)

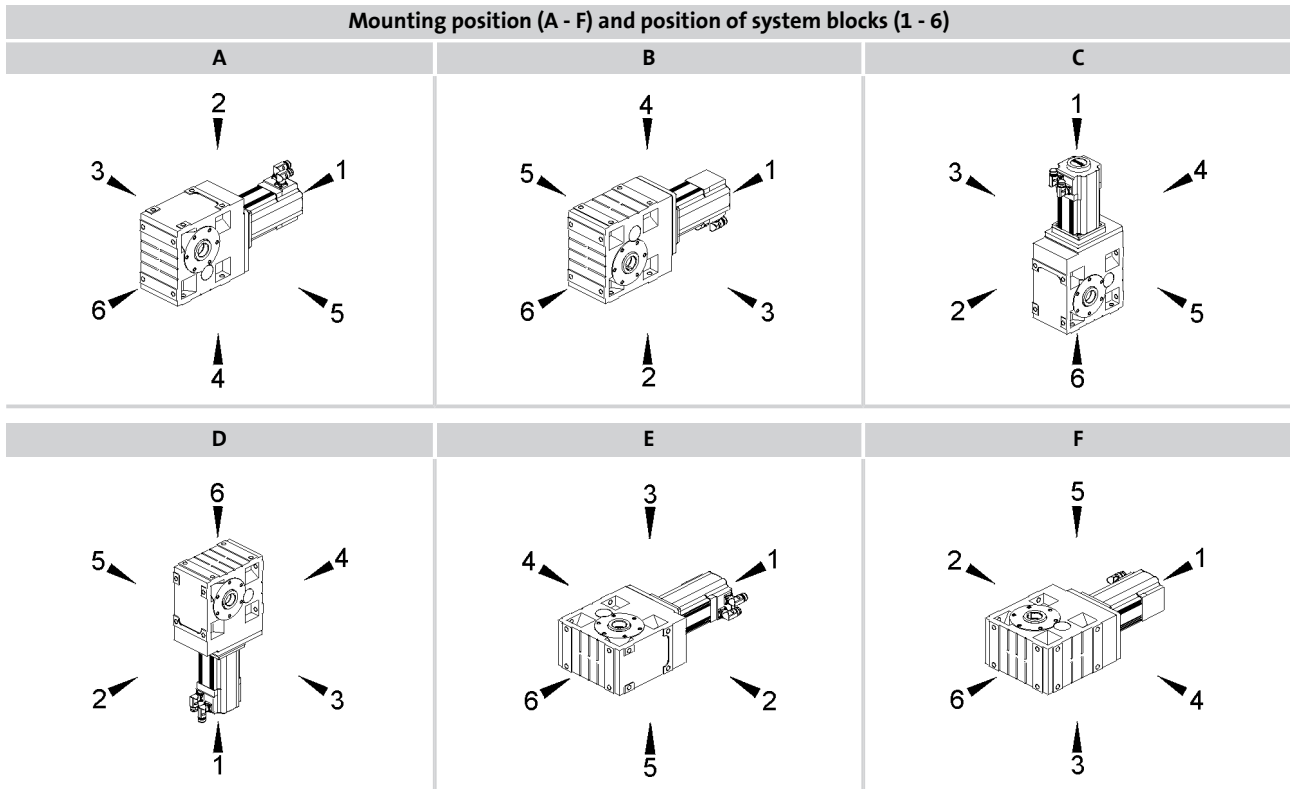

Solid shaft: 3, 5, 8 (3+5)
 Hollow shaft: 0
 Hollow shaft with shrink disc: 3, 5

Without flange: 0
 Flange: 3, 5, 8 (3+5)
 Connector/terminal box: 2, 3, 4, 5

Basic versions	
Colour	Grey primer RAL 9005 (jet black matt) paint
Lubricant	Synthetic CLP PG 460
Ventilation	Breather elements for GSS05 - 07 Oil control plugs for GSS05 - 07
Options	
Colour	Special paint in accordance with RAL
Lubricant	CLP PG 220 USDA H1
Shaft sealing rings	Driven shaft: Viton
Accessories	Threaded hole circle torque plate Casing foot torque plate 2nd output shaft end Cover shrink disc Hoseproof hollow shaft cover Hollow shaft circlip assembly kit

Ordering details checklist	
Product key	GSS...
Ratio	$i = \dots$
Shaft diameter	$d = \dots$ [mm]
Flange diameter	$a_2 = \dots$ [mm]
Mounting position	A, B, C, D, E, F
Position of system blocks	Shaft: 3, 5, 8 Flange: 0, 3, 5, 8 Connector/terminal box: 2, 3, 4, 5
Colour	
Options	

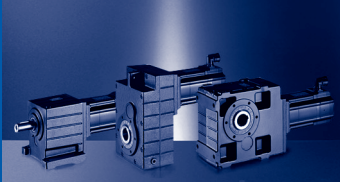

General information

Planetary gearbox product key

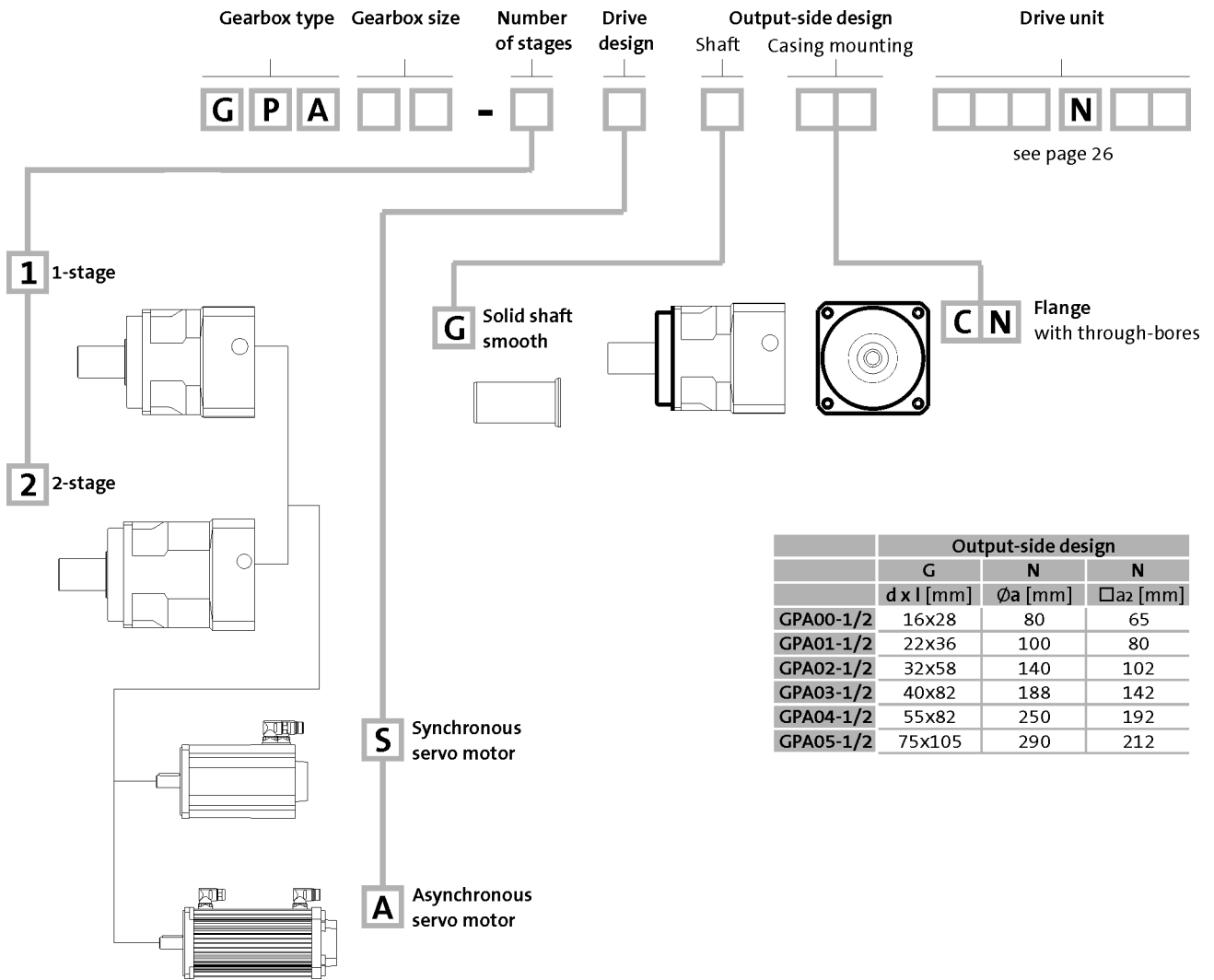

General information

Planetary gearbox product key

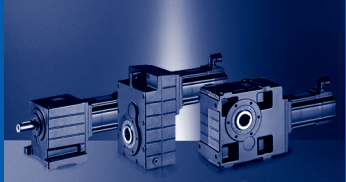

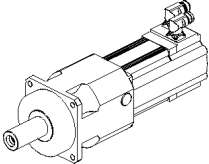
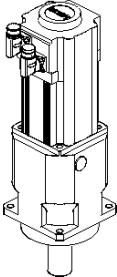
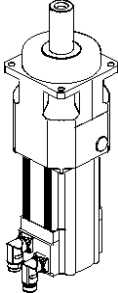
Mounting position (A - D)		
A	C	D
		

Basic versions	
Colour	RAL 9005 (jet black matt) paint
Lubricant	Synthetic CLP PAO 150

Ordering details checklist	
Product key	GPA...
Mounting position	A, C, D

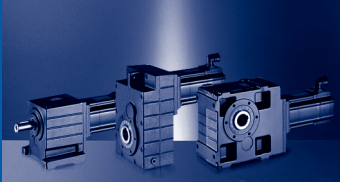

General information

Servo motors product key

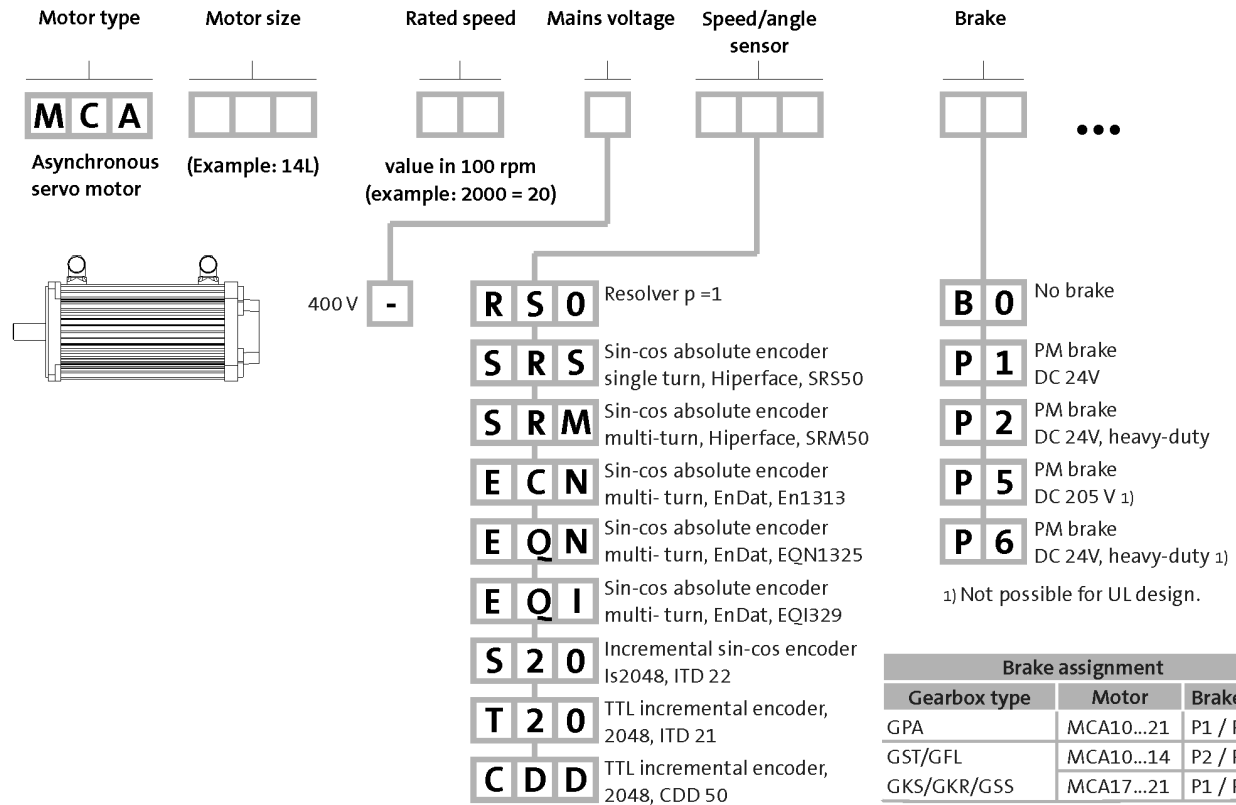
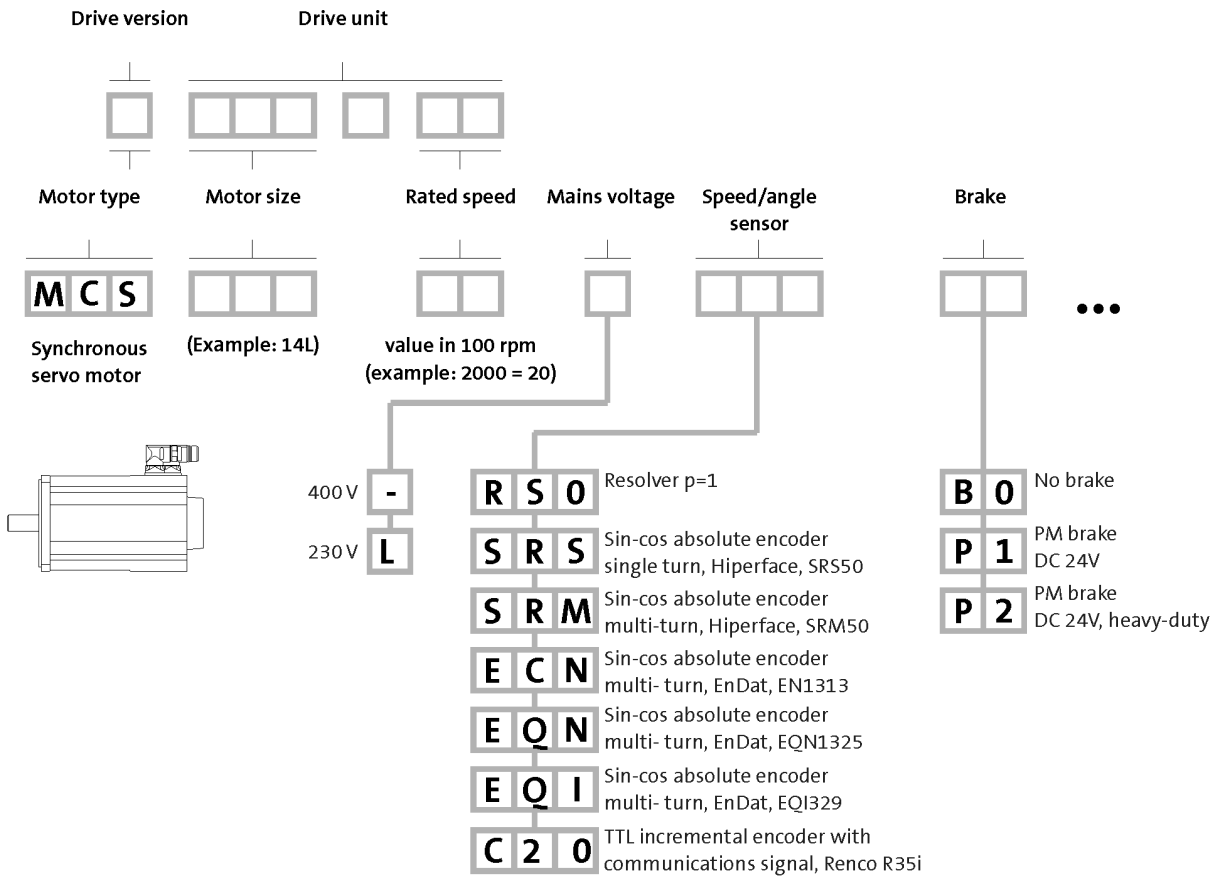

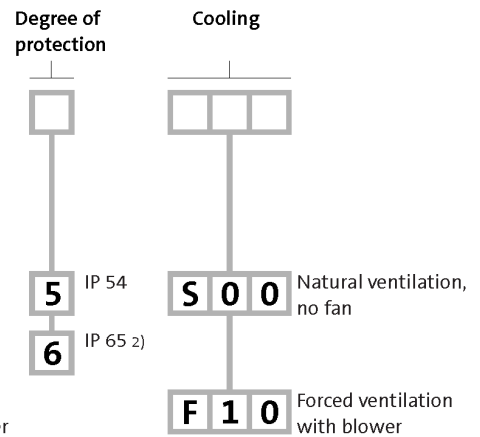
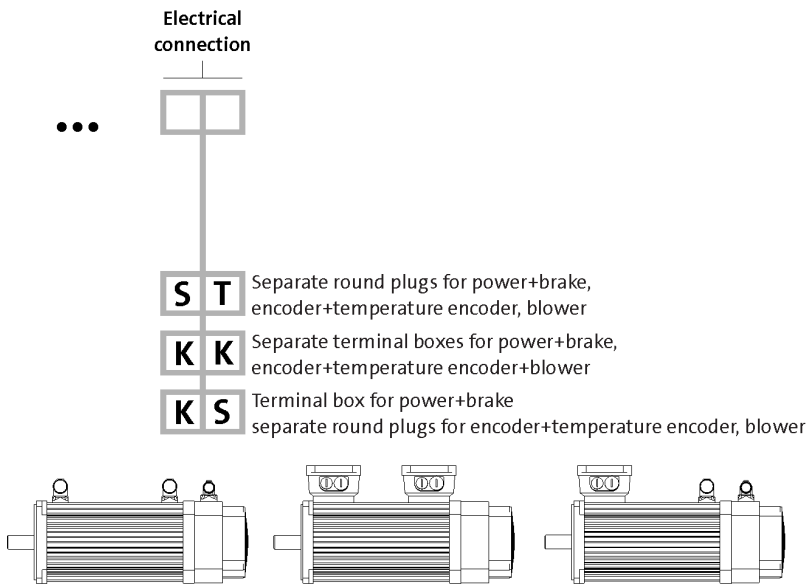
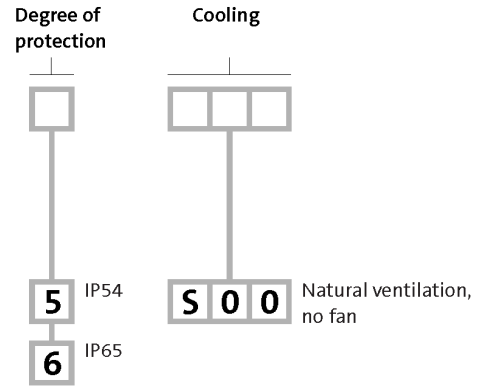
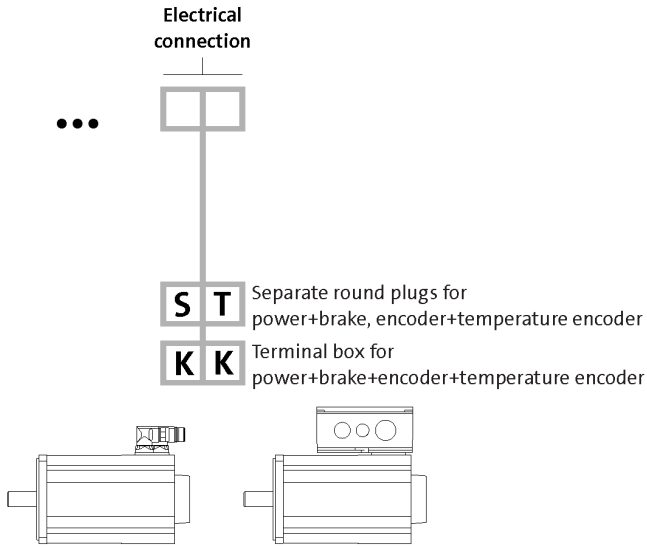
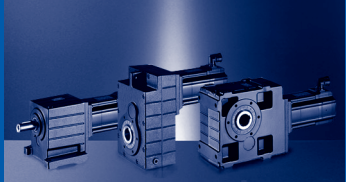

2) Not possible with blowers

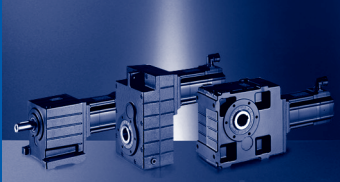

General information

Product information

Innovative geared motors combined with powerful drive electronics to meet the highest standards in terms of dynamics, positioning accuracy and robustness: the G-motion servo.

Featuring a wide variety of geared motors in the following variants:

- ▶ Helical gearboxes
- ▶ Shaft-mounted helical gearboxes
- ▶ Bevel gearboxes
- ▶ Helical-bevel gearboxes
- ▶ Helical-worm gearboxes
- ▶ Servo-planetary gearboxes

Lenze offers high levels of functionality while complying with many industrial standards. Closely stepped output speeds allow you to make the perfect choice for your drive task.

Lenze geared servo motors are available in a power range from 0.25...20.3 kW.

Together with the Lenze servo controllers, these geared motors offer a perfect drive combination with high dynamic performance.

- ▶ Power range of the synchronous servo motors: 0.25...10 kW
- ▶ Power range of the asynchronous servo motors: 0.8...20.3 kW

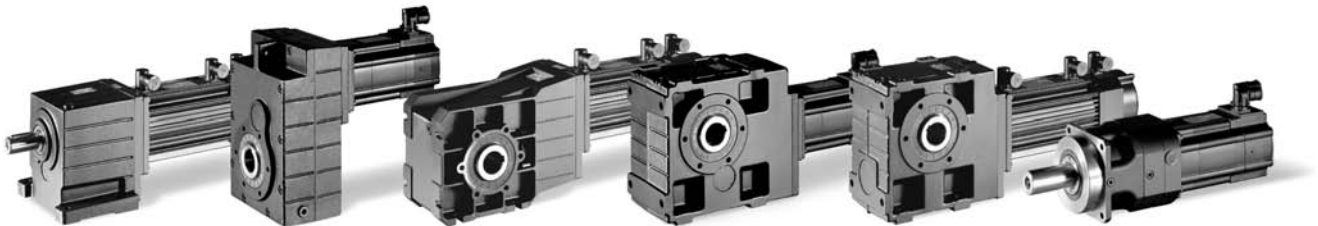

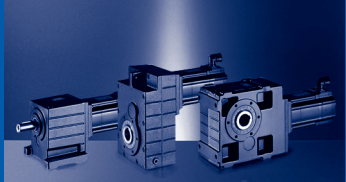

Designations used in the catalogue:

□	wildcard	k_{n1}	Speed correction factor for ambient temperature
α	Angle of action of radial force	k_{n2}	Speed correction factor for mounting position
φ	Ratio step	k_{n3}	Speed correction factor for duty time/average speed
η [%]	Mechanical efficiency	k_m	Speed correction factor for average speed
η_A [%]	Mechanical start-up efficiency of gearbox	KE_{LL} [V/1000 min ⁻¹]	Voltage constant (phase-to-phase)
$\eta_{c=1}$ [%]	Mechanical efficiency of gearbox with gearbox loading $c = 1$	Kt_0 [Nm/A]	Torque constant at standstill
η_G [%]	Mechanical efficiency of gearbox	$L_{1\sigma}$ [mH]	Stator leakage inductance
ϑ [°C]	Temperature	$L_{2\sigma}$ [mH]	Rotor leakage inductance (referred to stator)
AC	Alternating current/voltage	L_h [mH]	Mutual inductance
BD [h]	Operating time	L_{str} [mH]	Winding inductance per phase
c	Load capacity of geared motors	m [kg]	Mass
DC	Direct current/voltage	M_B [Nm]	Brake holding torque
ED	Duty time	M_{eff} [Nm]	Effective torque at output
f_α	Effective direction factor at output shaft	M_L [Nm]	Load torque
f_N [Hz]	Rated frequency	$M_{L,max}$ [Nm]	Maximum load torque
f_w	Additional load factor at output shaft	$M_{L,z}$ [Nm]	Stationary load torque per time segment
f_z	Additional radial force factor of transmission element	M_{max} [Nm]	Maximum motor torque
Fa [N]	Applied axial force	M_N [Nm]	Rated motor torque
Fa_{Tab} [N]	Table value of axial force	$M_{S,z}$ [Nm]	Acceleration torque
Fa_{zul} [N]	Permissible axial force	$M_{s,eff}$ [Nm]	Effective torque
Fr [N]	Applied radial force	M_z [Nm]	Output torque per time segment
Fr_{Tab} [N]	Table value of radial force	$M_{p,max}$ [Nm]	Maximum torque of profile
Fr_{zul} [N]	Permissible radial force	M_0 [Nm]	Continuous standstill torque
H [m]	Site altitude above sea level	M_1 [Nm]	Input torque
i	Ratio	M_2 [Nm]	Output torque
i_g	Precise ratio	$M_{2,max}$ [Nm]	Maximum output torque
I_B [A]	Rated brake current	$M_{2,GN}$ [Nm]	Rated gearbox torque at the output at $c=1$ and $n_1 = 1400 \text{ min}^{-1}$
I_{max} [A]	Maximum current	N	Start-ups
I_M [A]	Rated motor current	$n_{L,z}$ [min ⁻¹]	Load speed
I_0 [A]	Continuous standstill current	$\Delta n_{L,z}$ [min ⁻¹]	Load speed difference per time segment
J_B [kgcm ²]	Moment of inertia of the brake	n_{max} [min ⁻¹]	Maximum speed
J_G [kgcm ²]	Moment of inertia of the gearbox reduced to the motor shaft	n_N [min ⁻¹]	Rated speed
J_L [kgcm ²]	Moment of inertia of load at output shaft	n_m [min ⁻¹]	Mean speed
J_M [kgcm ²]	Moment of inertia of the motor	n_1 [min ⁻¹]	Input speed
k	Application factor (following DIN 3990)	$n_{1,max}$ [min ⁻¹]	Maximum input speed
k_l	Intensity of gearbox load capacity	n_2 [min ⁻¹]	Output speed
k_j	Load-matching factor	$n_{2,Eck}$ [min ⁻¹]	Output speed at rated motor speed
k_L	Overload factor		

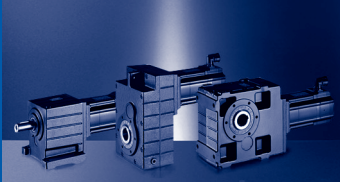

General information

List of abbreviations

Designations used in the catalogue:

$n_{2,th}$ [min ⁻¹]	Thermal limit speed at output
P_N [kW]	Rated power
R_1 [Ω]	Winding resistance per phase
R_2 [Ω]	Rotor resistance (referred to stator)
R_{UV} [Ω]	Winding resistance between 2 terminals
T [s]	Load cycle duration
t_L [%]	Runtime at maximum torque
T_U [°C]	Ambient operating temperature
Δt_z [s]	Individual time segments
U_B [V]	Rated brake voltage
U_N [V]	Rated motor voltage
z_g	Multiplied numbers of teeth (driven gears)
z_t	Multiplied numbers of teeth (driving gears)

IM	International Mounting Code
IP	International Protection Code
CE	Communauté Européene
CSA	Canadian Standards Association
DIN	Deutsches Institut für Normung
EMV	Electromagnetic compatibility
EN	European standard
IEC	International Electrotechnical Commission
NEMA	National Electrical Manufacturers Association
UL	Underwriters Laboratory
UR	Underwriters Laboratory recognized component
VDE	Verband deutscher Elektrotechniker

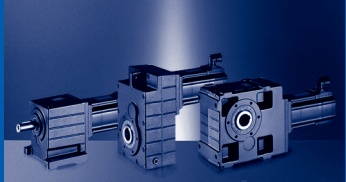

General information about the data provided in this catalogue

Power ratings, torques and speeds

The power ratings, torques and speeds specified in the catalogue are rounded values and apply to

- ▶ Daily running time of 8h, 240 days a year
- ▶ Ambient temperature up to 30°C
- ▶ Operating time 5.5 hrs a day
- ▶ Average speed utilisation in relation to the load speed of the geared motor: 80%
- ▶ Site altitude up to 1000 m above sea level.
- ▶ Mounting positions and designs listed in the catalogue (selection table relates to mounting position A).
- ▶ Standard lubricant.

Under different operating conditions, the values obtained may vary from those listed here.

In the case of extreme operating conditions, please contact your Lenze sales office.

Load capacity c of the gearboxes

Characteristic value for the load capacity of Lenze geared motors.

- ▶ c is the ratio of the permissible rated torque of the gearbox to the rated torque supplied by the drive component (e.g. the internal Lenze motor).
- ▶ c must always be greater than the application factor k determined for the application.

Application factor k (in accordance with DIN 3990)

Takes into account the influence of temporally variable loads which are actually present during the anticipated runtime of geared motors.

k depends on

- ▶ The type of load
- ▶ The intensity of the load
- ▶ Temporary factors

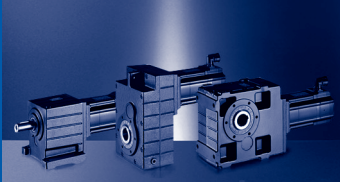

General information

Notes on ordering

We aim to process your order quickly and accurately. Therefore, please ensure that your order details are complete.

In order to receive the correct products in good time, please provide the following information:

- ▶ Your address and order data
- ▶ Our product keys for the individual products in this catalogue
- ▶ Your delivery details, such as delivery date and delivery address

Ordering procedure

Use the ordering details checklist to ensure that you provide all the necessary information for each product.

You can find the ordering details checklist, product key, basic designs, options, mounting position and system block positions in the chapter General information - Product key.

A list of Lenze sales offices can be found at the end of this catalogue.



Lenze wants to assist you in optimising your project planning processes. Drive selection and dimensioning is the foundation of all plant planning. This project planning manual for Lenze geared servo motors will guide you from the initial torque and speed input variables right through to a functional and efficient drive train. Your local Lenze sales office will assist you in drive dimensioning. Please consult us.

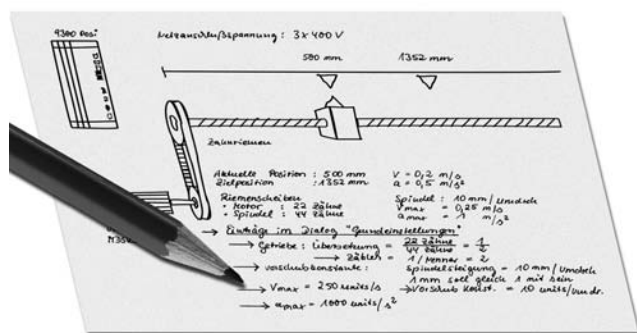

From the rough outline to the finished drive solution

After gathering information about the mechanical parameters and the motion profile, sales staff use the "Drive Solution Designer" to complete drive dimensioning and optimisation in next to no time.

The original application data and the results from the Drive Solution Designer are summarised in a document in a structured manner. The graphical analysis provides clear, comprehensive information about the drive load and configuration. The hardware required by the solution is documented; this simplifies the ordering process and means that the complete solution can be supplied quickly.

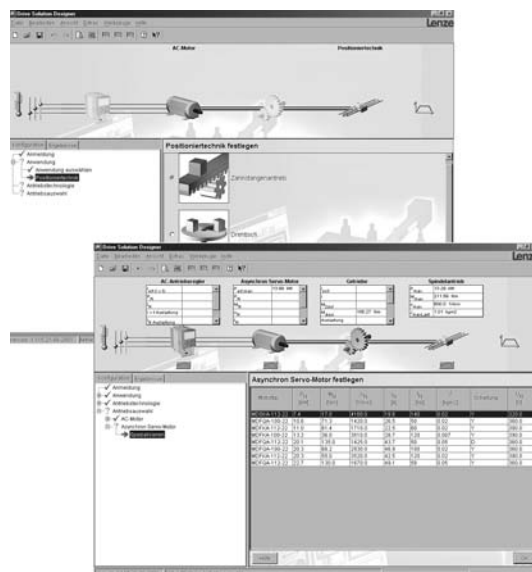



Drive dimensioning

Aim of dimensioning

This section describes the dimensioning of drives with geared servo motors.

The aim of dimensioning

is to select the right geared servo motor for a given application, ensuring that the requirements for the specific application are reliably met. The operating conditions concerned are taken into consideration in this process:

- ▶ Ambient temperature
- ▶ Mounting position
- ▶ Load cycle

For the sake of simplicity, the dimensioning given is for standard operating modes and for general load cycles:

- ▶ Constant load, operating mode **S1** *
- ▶ Short-time operation **S2**
- ▶ Intermittent operation **S3**
- ▶ Continuous operation **S6** *
- ▶ Load profiles for an **application-specific load cycle**

* For maximum life expectancy, Lenze recommends the use of motors with a low rated speed for operating modes S1 and S6.

Dimensioning involves 3 elements:

- ▶ **Satisfying the drive function** - Can the required speeds, torques, accelerations be achieved with the chosen drive?
- ▶ **Mechanical strength** - Can the drive withstand the torques and forces occurring?
- ▶ **Thermal dimensioning** - Does the operating temperature remain within the permissible limits, preventing premature ageing?

Drive function

The process values required are used to select a drive for which all working points lie within the speed/torque characteristic curves. This results in the selection of a gearbox of the correct ratio with a motor of the correct speed and an inverter with the correct maximum current. Other limits (maximum speed, site altitude) are shown in tables.

Mechanical strength

The forces and torques arising together with the application factor and the gearbox torque are used to select a drive with adequate mechanical strength (endurance strength of the gearing for periodically occurring torques and endurance limit for sporadically occurring torques).



Thermal dimensioning

For the **inverter**, thermal dimensioning uses the continuous inverter current or the continuous torque achievable by the motor/inverter combination.

For the **motor**, thermal dimensioning uses the average speed and the effective torque.

For the **gearbox**, thermal dimensioning uses the average speed and the continuous torque of the motor/gearbox combination. The thermal limit speed specified is intended as a recommendation. The average speed of the drive must not exceed the specified values.

Dimensioning in three steps

The dimensioning of geared servo motors can be divided into three steps, which are listed separately for each of the operating modes referred to above (S1, S2, S3, S6, profile):

Determination of input variables, including:

- ▶ Load torque, load speed, acceleration (for speed profiles, several working points with times)
- ▶ Maximum torque
- ▶ Mounting position
- ▶ Power loading
- ▶ Method of torque transmission

Calculation of values required for the process, including:

- ▶ Overall torques from load torque and acceleration
- ▶ Maximum load torque
- ▶ Effective torque
- ▶ Average speed
- ▶ Maximum speed

Selection of the geared servo motor and checking the selection for fulfilment of required values, including:

- ▶ Calculation of overall torque on the motor end (effective torque, maximum torque)
- ▶ Thermal checking of the motor by reference to effective torque and average speed
- ▶ Thermal checking of the gearbox by reference to average speed and effective torque
- ▶ Checking of maximum gearbox torque by reference to periodically occurring torques and sporadically occurring maximum torques
- ▶ Checking of the motor/inverter combination by reference to maximum torques
- ▶ Checking of load adjustment
- ▶ Checking of axial and radial force on the gearbox

To obtain a **reliable drive**, **particular attention** must be given to selecting and checking it. The various elements involved in dimensioning and checking are described in more detail below. Special emphasis is placed on **compliance with the limits of the geared servo motor drive** (functional limits, thermal limits, mechanical limits).



Dimensioning of geared servo motors for kinematic profiles, operating modes S1, S2, S3, S6 and speed profiles

Suitable for simple linear speed profiles, not for S-curves or similar. For complex or full-load dimensioning, please contact your local Lenze subsidiary.

Standard operating conditions:

- ▶ Single shift operation, 8 hours a day, 240 days a year
- ▶ Ambient temperature up to 30 °C
- ▶ Operating time 5.5 hours a day
- ▶ Average speed utilisation in relation to the load speed of the geared motor 80 %
- ▶ Mounting position A
- ▶ Site altitude up to 1000 m above sea level

Included

- ▶ Rated mains voltage AC 400 V, 3-phase
- ▶ Ambient temperature
- ▶ Site altitude
- ▶ Dimensioning with 9400, 9300 and ECS speed-torque characteristic curves for mains voltages of 400 V, 3-phase
- ▶ Process requirement
- ▶ Preselection of motor
- ▶ Load capacity of gearbox
- ▶ Intended transmission ratio
- ▶ Maximum permissible gearbox input speed
- ▶ Axial and radial load on gearbox output shaft
- ▶ Overall reduced moment of inertia
- ▶ Load adjustment to moments of inertia

Not included

- ▶ Correct consideration of efficiency in motor mode/generator mode
- ▶ Accessories such as brake choppers, brake resistors, feedback systems, mains filters
- ▶ Current derating on 9300 servo at low speeds
- ▶ Special ambient conditions such as special power system characteristics, high temperatures/site altitudes, contamination, outdoor use, explosion protection
- ▶ Maximum standstill current
- ▶ Setting the controller inhibit to reduce the heat load on the drive



The operating mode is important when selecting a motor. For example, the temperature rise on a motor subject to short-term load will be lower than that on a motor subject to long-term load. EN 60034 defines operating modes S1 to S8.

Continuous operation S1

The operating time at rated power is long enough for the machine to reach steady-state temperature. The motor operates continuously at rated power.

Short-time operation S2

In comparison with the subsequent pause, the operating time is too short for the machine to reach steady-state temperature. During the subsequent lengthy pause, the motor cools down to the initial temperature.

Intermittent operation S3, S4, S5

Cycles of the same type combine to form a sequence. The cycle time is usually 10 minutes.

- ▶ S3: The starting current is not significant for the temperature rise in the motor
- ▶ S4: The starting current contributes to the temperature rise in the motor
- ▶ S5: Starting current and braking current contribute to the temperature rise in the motor

Continuous operation with intermittent loading S6

The motor continues to be ventilated during the no-load phases, enabling it to cool down.

Uninterrupted operation with acceleration and braking S7

The motor runs almost without break.

Uninterrupted operation S8 with pole changing

The machine runs constantly under load but with frequent speed variation.



Drive dimensioning

Operating mode S1

Dimensioning of geared servo motors for operating mode S1 (EN 60034)

The drive is constantly loaded in operating mode S1, there may be a change of direction of rotation or an alternating load.
Precondition: constant power loss, neglect of start-up process (constant temperature rise)

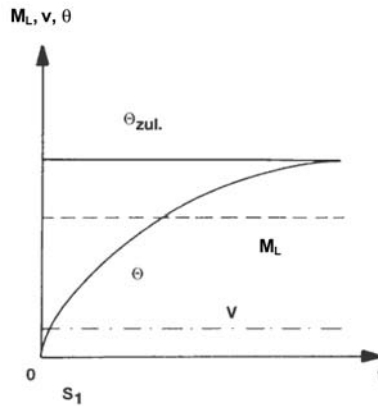

Required input variables			
Operating time/day	BD =		[h]
Average speed utilisation of the geared motor related to the speed under load n_L			[%]
Ambient temperature	$T_u =$		[°C]
Site altitude above sea level	H =		[m]
Radial force	$F_r =$		[N]
Axial force	$F_a =$		[N]
Transmission element at gearbox (gear wheels, sprockets...)			
Pitch circle diameter of the transmission element	$d_w =$		[mm]
Load torque	$M_L =$		[Nm]
Load speed	$n_L =$		[min ⁻¹]
Momentary maximum torque (emergency off, quick stop, occasional high starting duty)	$M_{L,max} =$		[Nm]
Runtime at maximum torque	$t_L =$		[%]
Determine gearbox design and servo motor design			
Gearbox type (GST, GFL, GKR, GKS, GSS, GPA)			
Mounting position (A, B, C, D, E, F)			
Output designs (shaft design: hollow shaft, solid shaft...)			
Input design (A asynchronous/S synchronous)			
Cooling type (S00 without fan/F10 with blower)			

→  14 - General information - Product key



Determine gearbox size from the forces		
Determination of the axial and radial forces acting on the gearbox shaft		
	Calculation	Check
Additional radial force factor of transmission element	$f_z =$	
Radial force	$Fr = 2000 \cdot \frac{M_{L,max} \cdot f_z}{d_w}$	$Fr \leq Fr_{zul} = \min(f_w \cdot f_\alpha \cdot Fr_{Tab}; f_w \cdot Fr_{max})$
Axial force		$Fa \leq Fa_{zul} = Fa_{Tab} \quad , \quad Fr = 0$

→ 52 - f_z

→ Permissible radial and axial forces $G \square \square$ [N]
 $Fr_{Tab}, Fa_{Tab}, f_w, f_\alpha$

Determine speed correction factors	
Ambient temperature, site altitude	$k_{n1} =$
Mounting position	$k_{n2} =$
Average speed utilisation of the geared motor (in % of n_L) and daily operating time	$k_{n3} =$
	$k_n = k_{n1} \cdot k_{n2} \cdot k_{n3}$

→ 51 - k_{n1}, k_{n2}, k_{n3}

Select and check the geared servo motor-inverter combination			
For maximum life expectancy, Lenze recommends the use of motors with a low rated speed for operating modes S1 and S6.			
	Check	Selection	
Output torque	$M_2 \geq M_L$	$M_2 =$	[Nm]
Output speed (recommendation)	$n_{2,th} \geq \frac{n_L}{k_n}$	$n_{2,th} =$	[min ⁻¹]
Output speed	$n_{2,Eck} \geq n_L$	$n_{2,Eck} =$	
Alternating load influence: without alternating load	$M_{2,GN} \geq M_L$	$M_{2,GN} =$	[Nm]
Alternating load influence: with alternating load	$M_{2,GN} \geq M_L \cdot 1.4$		
Ratio		$i =$	
Load capacity of the geared motor		$c =$	
Momentary maximum torque	$M_{2,max} = M_{2,GN} \cdot 1.5 \geq M_{L,max}$	$M_{2,max} =$	[Nm]

→ Selection tables $G \square \square$ [Nm]

$M_2, M_{2,GN}, n_{2,th}, n_{2,Eck}, i, c$

→ 50 - Motors for operating modes S1 and S6

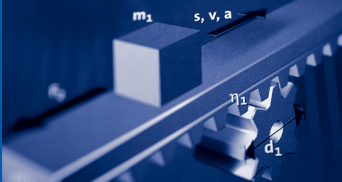

Drive dimensioning

Operating mode S1

Determine the required gearbox load capacity		
Calculate intensity	Without alternating load	k ₁ =
	$k_1 = \frac{M_{L,max}}{M_2}$	
	With alternating load	k ₁ =
	$k_1 = \frac{M_{L,max}}{M_2} \cdot 1.4$	
At runtime t _L > 10%: take intensity k ₁ from the calculation into account At runtime t _L ≤ 10%: take load factor k from the diagram into account		k =
Required load capacity	t _L > 10% → c ≥ k ₁	c =
	t _L ≤ 10% → c ≥ k	

→  52 - K



Dimensioning of geared servo motors for operating modes S2, S3 and S6 (EN 60034)

Short-time operation S2: Short-time running of the drive followed by a “long” pause

Periodic intermittent operation S3: Periodic alternation of the drive between on and off (maximum cycle time 10 minutes)

Periodic intermittent loading S6: The load alternates between on and off with the motor running constantly (maximum cycle time 10 minutes).

The acceleration process is ignored. Dimensioning for profile is required for dynamic applications.

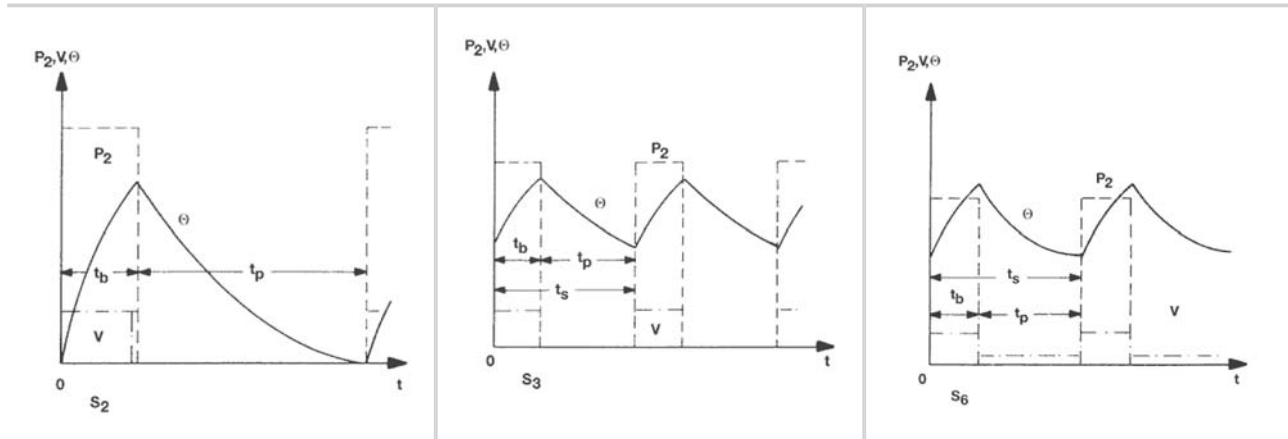

Required input variables			
Operating time/day	BD =		[h]
Average speed utilisation of the geared motor related to the speed under load n_L			[%]
Operating mode	S2 - ED = S3, S6 - ED =		[min] [%]
Ambient temperature	$T_u =$		[°C]
Site altitude above sea level	H =		[m]
Radial force	Fr =		[N]
Axial force	Fa =		[N]
Transmission element at gearbox (gear wheels, sprockets...)			
Pitch circle diameter of the transmission element	$d_w =$		[mm]
Load torque	$M_L =$		[Nm]
Load speed	$n_L =$		[min ⁻¹]
Momentary maximum torque (emergency off, quick stop, occasional high starting duty)	$M_{L,max} =$		[Nm]
Runtime at maximum torque	$t_L =$		[%]



Drive dimensioning

Operating modes S2, S3 and S6

Determine gearbox design and servo motor design	
Gearbox type (GST, GFL, GKR, GKS, GSS, GPA)	
Mounting position (A, B, C, D, E, F)	
Output designs (shaft design: hollow shaft, solid shaft...)	
Input design (A asynchronous/S synchronous)	
Cooling type (S00 without fan/F10 with blower)	

→ 14 - General information - Product key

Determine gearbox size from the forces		
Determination of the axial and radial forces acting on the gearbox shaft		
	Calculation	Check
Additional radial force factor of transmission element	$f_z =$	
Radial force	$Fr = 2000 \cdot \frac{M_{L,max} \cdot f_z}{d_w}$	$Fr \leq Fr_{zul} = \min(f_w \cdot f_\alpha \cdot Fr_{Tab}; f_w \cdot Fr_{max})$
Axial force		$Fa \leq Fa_{zul} = Fa_{Tab} \quad , \quad Fr = 0$

→ 52 - f_z

→ Permissible radial and axial forces $G \square \square$ [N]
 $Fr_{Tab}, Fa_{Tab}, f_w, f_\alpha$

Determine speed correction factors	
Ambient temperature, site altitude	$k_{n1} =$
Mounting position	$k_{n2} =$
Average speed utilisation of the geared motor (in % of n_{II}) and daily operating time	$k_{n3} =$

→ 51 - k_{n1}, k_{n2}, k_{n3}

Speed correction factors for average speed k_m					
Op. mode S2		Op. mode S3		Op. mode S6	
ED [min]	k_m	ED [%]	k_m	ED [%]	k_m
10	0.16	15	0.15	15	1
30	0.5	25	0.25	25	
60	1	40	0.4	40	
90		60	0.6	60	

$$k_m =$$

$$k_n = \frac{k_{n1} \cdot k_{n2} \cdot k_{n3}}{k_m}$$



Specify the overload factor k_L (guide values) as a function of the application/kinematics					
Op. mode S2		Op. mode S3		Op. mode S6	
ED [min]	k_L	ED [%]	k_L	ED [%]	k_L
10	1.4-1.5	15	1.4-1.5	15	1.5-1.6
30	1.15-1.2	25	1.3-1.4	25	1.4-1.5
60	1.07-1.1	40	1.15-1.2	40	1.3-1.4
90	1.0-1.05	60	1.05-1.1	60	1.15-1.2

$k_L =$

Select and check the geared servo motor-inverter combination			
For maximum life expectancy, Lenze recommends the use of motors with a low rated speed for operating modes S1 and S6.			
	Check	Selection	
Output torque	$M_2 \geq \frac{M_L}{k_L}$	$M_2 =$	[Nm]
Output speed (recommendation)	$n_{2,th} \geq \frac{n_L}{k_n}$	$n_{2,th} =$	[min ⁻¹]
Output speed	$n_{2,Eck} \geq n_L$	$n_{2,Eck} =$	
Alternating load influence: without alternating load	$M_{2,GN} \geq M_L$	$M_{2,GN} =$	[Nm]
Alternating load influence: with alternating load	$M_{2,GN} \geq M_L \cdot 1.4$		
Ratio		$i =$	
Load capacity of the geared motor		$c =$	
Efficiency of gearbox	$\eta_G = \eta_{c=1} - (c-1) \cdot 0.01$	$\eta_G =$	
Momentary maximum torque	$M_{2,max} = M_{2,GN} \cdot 1.5 \geq M_{L,max}$	$M_{2,max} =$	[Nm]
Thermally effective working point (○) below S1 torque characteristic of the servo motor		$\left(\frac{i \cdot k_m \cdot n_L}{k_{n3}}, \frac{M_L}{k_L \cdot i \cdot \eta_G} \right)$	
All working points (●) below the maximum torque characteristic of the servo motor/inverter combination, taking $M_{L,max}$ into account		$\left(i \cdot n_L, \frac{M_L}{i \cdot \eta_G} \right)$	

- Selection tables G□□ [Nm]
 $M_2, M_{2,GN}, n_{2,th}, n_{2,Eck}, i, c$
- Servo motors catalogue
Torque characteristics
- 50 - Motors for operating modes S1 and S6
- 53 - $\eta_{c=1}$

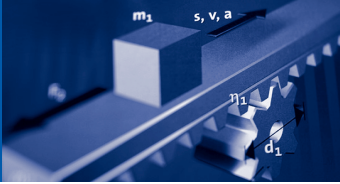

Drive dimensioning

Operating modes S2, S3 and S6

Determine the required gearbox load capacity		
Calculate intensity	Without alternating load $k_1 = \frac{M_{L,max}}{M_2}$	k ₁ =
	With alternating load $k_1 = \frac{M_{L,max}}{M_2} \cdot 1.4$	
At runtime $t_L > 10\%$: take intensity k_1 from the calculation into account At runtime $t_L \leq 10\%$: take load factor k from the diagram into account		k =
Required load capacity	$t_L > 10\% \rightarrow c \geq k_1$ $t_L \leq 10\% \rightarrow c \geq k$	c =

→  52 - K



Dimensioning of geared servo motors with speed profiles, cycle time/load cycle duration ≤ 1 min

The profiles, some examples of which are shown below, must be determined.
A small sketch of the movement to be carried out can help with the subsequent calculation.

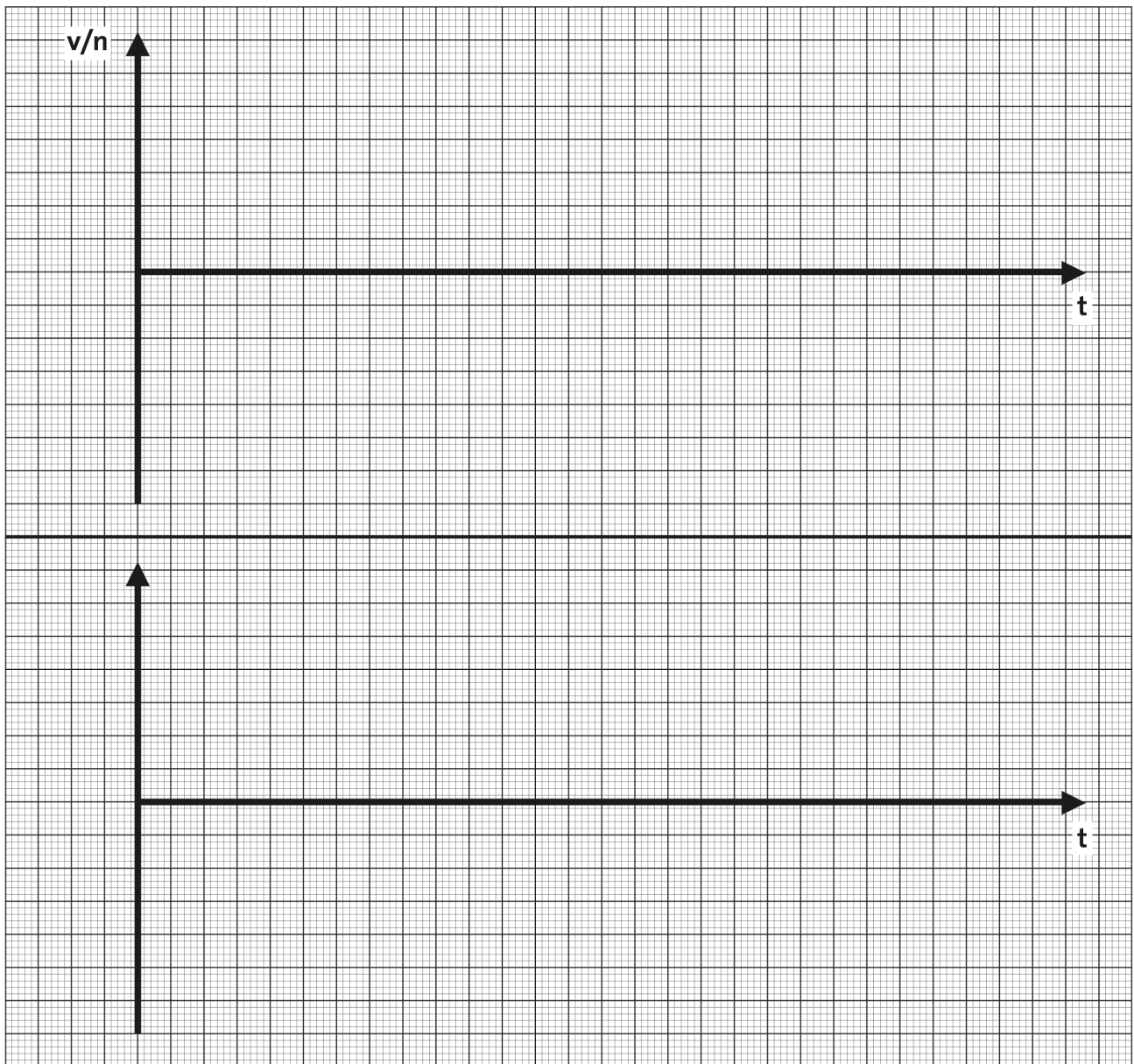
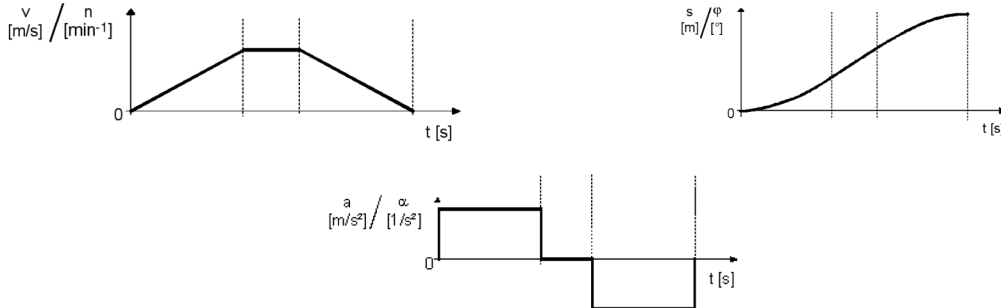

Drive dimensioning

Speed profiles

Required input variables			
Operating time/day	BD =		[h]
Average speed utilisation of the geared motor related to the speed under load n_L			[%]
Ambient temperature	$T_u =$		[°C]
Site altitude above sea level	H =		[m]
Radial force	$F_r =$		[N]
Axial force	$F_a =$		[N]
Transmission element at gearbox (gear wheels, sprockets...)			
Pitch circle diameter of the transmission element	$d_w =$		[mm]
Momentary maximum torque (emergency off, quick stop, occasional high starting duty)	$M_{L,max} =$		[Nm]
Runtime at maximum torque	$t_L =$		[%]

Time characteristic of load for the individual time segments z

Total time	Individual time segments	Load speed	Load speed variation	Stationary load torque	Torque	Acceleration torque	Moment of inertia
t [s]	Δt_z [s]	$n_{L,z}$ [min ⁻¹]	$\Delta n_{L,z}$ [min ⁻¹]	$M_{L,z}$ [Nm]	M_z [Nm]	$M_{s,z}$ [Nm]	J_L [kgm ²]

Load cycle duration	$T = \sum \Delta t_z$	T =	[s]
---------------------	-----------------------	-----	-----

Calculation of values required for the process

Torque per time segment	$M_z = M_{L,z} + J_L \cdot \frac{2\pi \cdot \Delta n_{L,z}}{60 \cdot \Delta t_z} = M_{L,z} + 0.105 \cdot \frac{\Delta n_{L,z}}{\Delta t_z} \cdot J_L$		
Maximum torque of profile	$M_{p,max} = \max(M_z)$	$M_{p,max} =$	[Nm]
Effective torque	$M_{eff} = \sqrt{\frac{1}{T} \sum_z M_z^2 \cdot \Delta t_z}, T \leq 1 \text{ min}$	$M_{eff} =$	[Nm]
Mean speed	$n_m = \overline{n_{L,z}} = \frac{1}{T} \sum_z n_{L,z} \cdot \Delta t_z$	$n_m =$	[min ⁻¹]
Maximum speed	$n_{max} = \max(n_{L,z})$	$n_{max} =$	[min ⁻¹]



Determine gearbox design and servo motor design	
Gearbox type (GST, GFL, GKR, GKS, GSS, GPA)	
Mounting position (A, B, C, D, E, F)	
Output designs (shaft design: hollow shaft, solid shaft...)	
Input design (A asynchronous/S synchronous)	
Cooling type (S00 without fan/F10 with blower)	

→ 14 - General information - Product key

Determine gearbox size from the forces		
Determination of the axial and radial forces acting on the gearbox shaft		
	Calculation	Check
Additional radial force factor of transmission element	$f_z =$	
Radial force	$Fr = 2000 \cdot \frac{M_{L,max} \cdot f_z}{d_w}$	$Fr \leq Fr_{zul} = \min(f_w \cdot f_\alpha \cdot Fr_{Tab}; f_w \cdot Fr_{max})$
Axial force		$Fa \leq Fa_{zul} = Fa_{Tab} \quad , \quad Fr = 0$

→ 52 - f_z

→ Permissible radial and axial forces $G \square \square$ [N]
 $Fr_{Tab}, Fa_{Tab}, f_w, f_\alpha$

Determine speed correction factors	
Ambient temperature, site altitude	$k_{n1} =$
Mounting position	$k_{n2} =$
Average speed utilisation of the geared motor (in % of n_{II}) and daily operating time	$k_{n3} =$
	$k_n = k_{n1} \cdot k_{n2} \cdot k_{n3}$



→ 51 - kn_1, kn_2, kn_3



Drive dimensioning

Speed profiles

Select and check the geared servo motor-inverter combination	Check	Preselection	
Output torque	$M_2 > M_{\text{eff}}$	$M_2 =$	[Nm]
Output speed (recommendation)	$n_{2,\text{th}} \geq \frac{n_m}{k_n}$	$n_{2,\text{th}} =$	[min ⁻¹]
Output speed	$n_{2,\text{Eck}} \geq n_L$	$n_{2,\text{Eck}} =$	
Maximum speed	$n_{1,\text{max}} \geq n_{\text{max}} \cdot i$	$n_{1,\text{max}} =$	
Alternating load influence: without alternating load	$M_{2,\text{GN}} \geq M_{\text{p,max}}$	$M_{2,\text{GN}} =$	[Nm]
Alternating load influence: with alternating load	$M_{2,\text{GN}} \geq M_{\text{p,max}} \cdot 1,4$		
Load capacity of the geared motor		$c =$	
Efficiency of gearbox	$\eta_G = \eta_{c=1} - (c-1) \cdot 0,01$	$\eta_G =$	
Ratio	$i \approx \sqrt{\frac{J_L}{J_G + J_M + J_B}}$ (Optimum $k_j = 1$)	$i =$	
Load-matching factor (for optimum dynamics/control properties)	Requirement $k_j = 0.5 \dots 10$ Optimum $k_j = 1$	$k_j = \frac{J_L}{i^2 \cdot (J_G + J_M + J_B)}$	

- Selection tables G□□ [Nm]
 $M_2, M_{2,\text{GN}}, n_{2,\text{th}}, n_{2,\text{Eck}}, i, c, J_G, J_M$
- Servo motors catalogue
 J_B
-  50 - $n_{1,\text{max}}$
-  53 - $\eta_{c=1}$

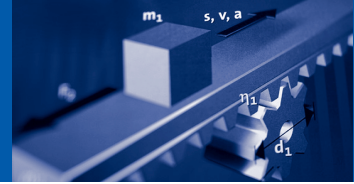

Check the motor torques		
Taking into account the mass inertia of gearbox, motor and brake		
Acceleration torque	$M_{S,z} = M_z + (J_{GM} + J_B) \cdot \frac{2\pi \cdot \Delta n_{L,z}}{60 \cdot \Delta t_z} \cdot i^2$	$M_{S,z} =$
Effective torque	$M_{S,eff} = \sqrt{\frac{1}{T} \sum_z M_{S,z}^2 \cdot \Delta t_z}$	$M_{S,eff} =$
Thermally effective working point (○) below S1 torque characteristic of the servo motor		$\left(\frac{i \cdot n_m}{k_{n3}}, \frac{M_{S,eff}}{i \cdot \eta_G} \right)$
All working points (●) below the maximum torque characteristics of the servo motor/inverter combination		$\left(i \cdot n_{L,z}, \frac{M_{S,z}}{i \cdot \eta_G} \right)$

→ Servo motors catalogue
Torque characteristics

Determine the required gearbox load capacity		
Calculate intensity	Without alternating load $k_1 = \frac{M_{L,max}}{M_2}$	$k_1 =$
	With alternating load $k_1 = \frac{M_{L,max}}{M_2} \cdot 1.4$	
At runtime $t_L > 10\%$: take intensity k_1 from the calculation into account At runtime $t_L \leq 10\%$: take load factor k from the diagram into account		$k =$
Required load capacity	$t_L > 10\% \rightarrow c \geq k_1$ $t_L \leq 10\% \rightarrow c \geq k$	$c =$

→ 52 - K

Maximum gearbox input speeds

- ▶ These may not be exceeded, even momentarily.

Motor type	Input speeds	Motor type	Input speeds
	$n_{1,max} [min^{-1}]$		$n_{1,max} [min^{-1}]$
MCA10...	5000	MCS06...	5000
MCA13...			
MCA14...			
MCA17...			
MCA19...			
MCA21...	4000	MCS19...	4000

Recommended motors for operating modes S1 and S6

- ▶ With operating modes S1 and S6, the motor rotates at a constant, high speed. Motors with low rated speeds are preferable in respect of service life and oil temperature rise.

Motor type	Motor type
MCA10I40	MCS06C41
MCA13I41	MCS06F41
MCA13I34	MCS06I41
MCA14L20	MCS09D41
MCA14L16	MCS09F38
MCA17N23	MCS09H41
MCA17N17	MCS09L41
MCA19S23	MCS12D20
MCA19S17	MCS12H15
MCA21X25	MCS12L20
MCA21X17	MCS14D15
-	MCS14H15
-	MCS14L15
-	MCS14P14
-	MCS19F14
-	MCS19J14
-	MCS19P14



Ambient temperature and site altitude k_{n1}

Ambient temperature	Site altitude H [m] above sea level			
	< 1000	< 2000	< 3000	< 4000
T_u [°C]	k_{n1}	k_{n1}	k_{n1}	k_{n1}
≤ 20	1.15	1.04	0.92	0.81
30	1	0.9	0.8	0.7
40	0.8	0.72	0.64	0.56
50	0.6	0.54	0.48	0.42
60	0.4	0.36	0.32	0.28

Mounting positions k_{n2}

Gearbox type	Mounting position					
	A	B	E	D	E	F
	k_{n2}	k_{n2}	k_{n2}	k_{n2}	k_{n2}	k_{n2}
GST	1	0.8	0.8	0.7 ¹⁾	1	1
GFL	1	0.8	0.85	0.7 ¹⁾	0.9	0.8
GKR	1	0.9	0.8	0.8 ¹⁾	0.95	0.95
GKS	1	0.8	0.8	0.7 ¹⁾	0.8	0.8
GSS	1	0.9	0.8	0.8 ¹⁾	0.95	0.95
GPA	1	-	0.8	0.7 ¹⁾	-	-

¹⁾ The average input speed n_1 should not exceed 1500 min⁻¹.

Daily operating time and average speed utilisation of the geared motor k_{n3}

Daily operating time	Average speed utilisation of the geared motor related to the speed under load n_L				
	100%	80%	60%	50%	25%
[h]	k_{n3}	k_{n3}	k_{n3}	k_{n3}	k_{n3}
1	1.29	1.33	1.38	1.42	1.55
2	1.15	1.2	1.25	1.29	1.42
3	1.08	1.12	1.17	1.21	1.34
4	1.02	1.06	1.12	1.15	1.29
5.5	0.96	1	1.06	1.09	1.22
8	0.89	0.93	0.99	1.02	1.15
12	0.81	0.85	0.91	0.94	1.08
16	0.76	0.8	0.85	0.89	1.02
22	0.71	0.76	0.81	0.85	0.98
24	0.68	0.72	0.78	0.81	0.94

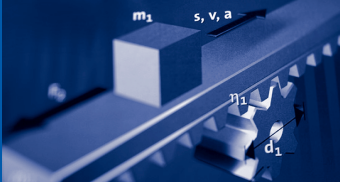

Drive dimensioning

Additional radial force factors/Application factors

Additional radial force factors for the transmission elements

Transmission element	Additional radial force factor
	f_z
Gear wheels	1.12
Sprockets	1.25...1.4
Toothed belt pulleys	1.5
Narrow V-belt, depending on tension	1.5 ... 2.0

Application factors GPA

Take application factor k of the machine from the diagram into account.
Interpolation between the curves is permissible.

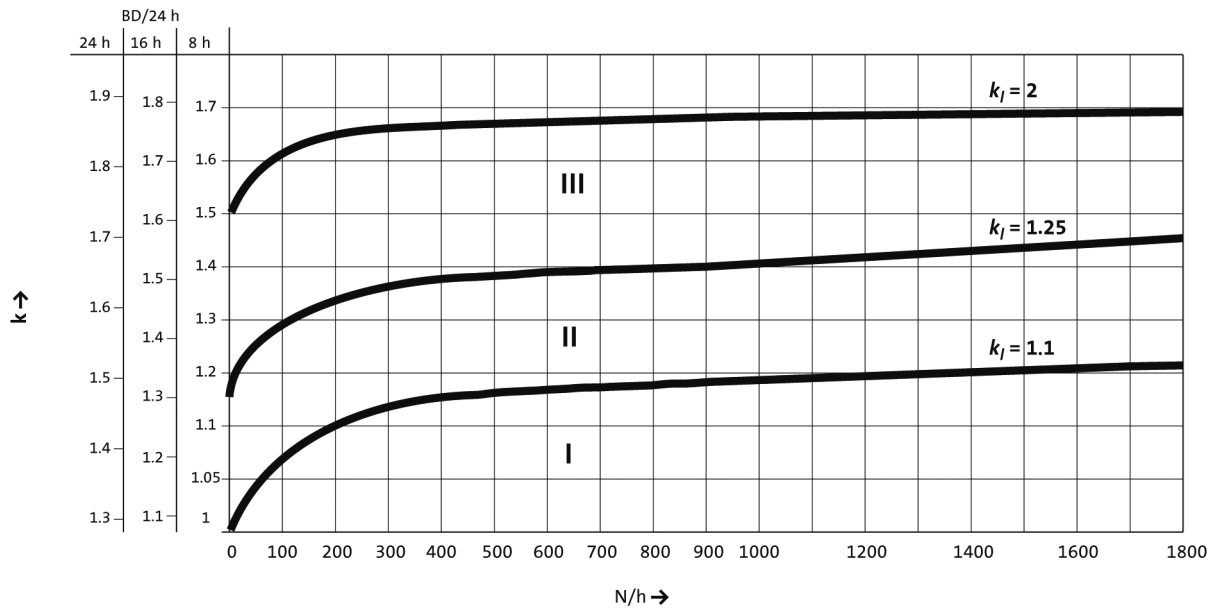

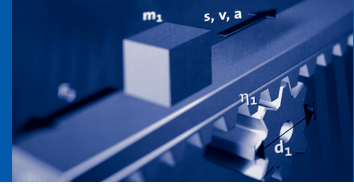

Application factors

GST, GFL, GKR, GKS, GSS

Take application factor k of the machine from the diagram into account.
Interpolation between the curves is permissible.

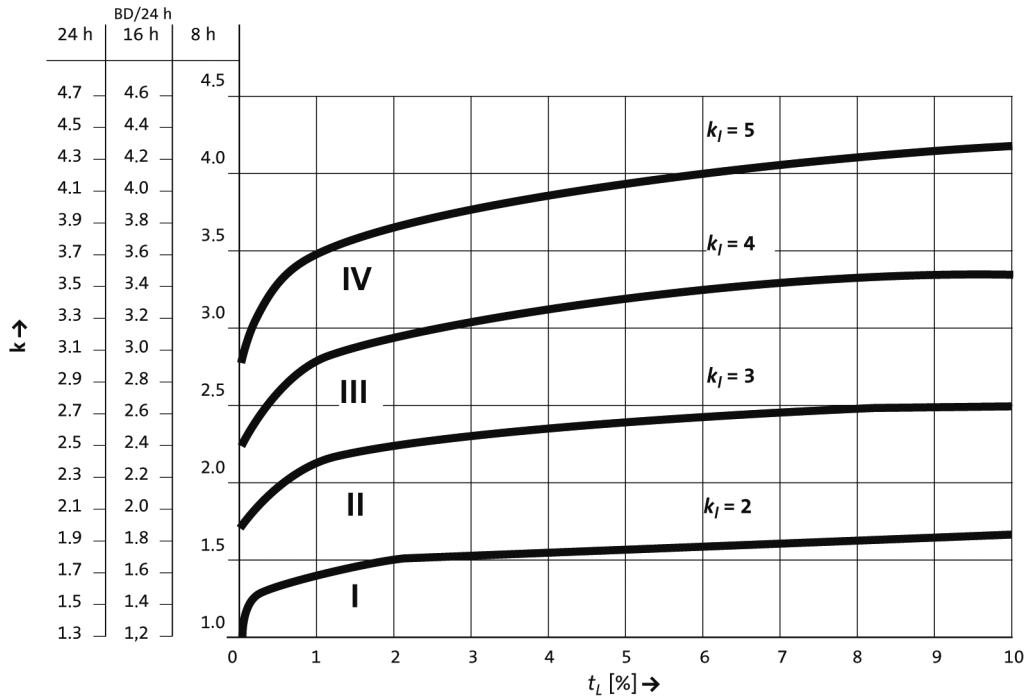

Efficiencies

Gearbox type	Number of stages			
	1	2	3	4
	$\eta_{c=1}$	$\eta_{c=1}$	$\eta_{c=1}$	$\eta_{c=1}$
GST	0.98	0.97	0.95	
GFL		0.97	0.95	
GKR		0.95		
GKS			0.95	0.93
GPA	0.97	0.95		



Drive dimensioning

GSS efficiencies

The start-up efficiency η_A of a helical-worm gearbox is lower than its operative efficiency at rated speed.

The start-up efficiency η_A must therefore always be taken into consideration when starting under load.

		Output speeds n_2 [min ⁻¹]														
		I	1	5	10	16	25	32	40	63	100	160	250	400	630	800
		η_A	$\eta_{c=1}$	$\eta_{c=1}$	$\eta_{c=1}$	$\eta_{c=1}$	$\eta_{c=1}$	$\eta_{c=1}$	$\eta_{c=1}$	$\eta_{c=1}$	$\eta_{c=1}$	$\eta_{c=1}$	$\eta_{c=1}$	$\eta_{c=1}$	$\eta_{c=1}$	$\eta_{c=1}$
GSS04-2	5.639	0.71	0.78	0.79	0.83	0.86	0.88	0.89	0.89	0.9	0.9	0.9	0.9	0.9	0.89	0.89
	7.733	0.67	0.74	0.76	0.81	0.84	0.86	0.87	0.87	0.88	0.88	0.87	0.87	0.87	0.87	-
	9.042	0.71	0.78	0.79	0.83	0.86	0.88	0.89	0.89	0.9	0.9	0.9	0.9	0.9	0.89	0.89
	9.897	0.67	0.74	0.76	0.81	0.84	0.86	0.87	0.87	0.88	0.88	0.87	0.87	0.87	0.87	-
	10.827	0.71	0.78	0.79	0.83	0.86	0.88	0.89	0.89	0.9	0.9	0.9	0.9	0.9	0.89	0.89
	12.4	0.67	0.74	0.76	0.81	0.84	0.86	0.87	0.87	0.88	0.88	0.87	0.87	0.87	0.87	-
	13.81	0.71	0.78	0.79	0.83	0.86	0.88	0.89	0.89	0.9	0.9	0.9	0.9	0.9	0.89	0.89
	15.869	0.67	0.74	0.76	0.81	0.84	0.86	0.87	0.87	0.88	0.88	0.87	0.87	0.87	0.87	-
	17.36	0.67	0.74	0.76	0.81	0.84	0.86	0.87	0.87	0.88	0.88	0.87	0.87	0.87	0.87	-
	20.417	0.55	0.6	0.71	0.76	0.78	0.79	0.79	0.79	0.79	0.79	0.78	0.78	-	-	-
	22.143	0.67	0.74	0.76	0.81	0.84	0.86	0.87	0.87	0.88	0.88	0.87	0.87	0.87	0.87	0.87
	24.8	0.56	0.62	0.72	0.77	0.79	0.8	0.81	0.81	0.81	0.8	0.8	0.79	-	-	-
	27.125	0.67	0.74	0.76	0.81	0.84	0.86	0.87	0.87	0.88	0.88	0.87	0.87	0.87	0.87	0.87
	31.738	0.56	0.62	0.72	0.77	0.79	0.8	0.81	0.81	0.81	0.8	0.8	0.79	-	-	-
	34.1	0.67	0.74	0.76	0.81	0.84	0.86	0.87	0.87	0.88	0.88	0.87	0.87	0.87	0.87	0.87
	39.2	0.55	0.6	0.71	0.76	0.78	0.79	0.79	0.79	0.79	0.79	0.78	0.78	-	-	-
	43.917	0.67	0.74	0.76	0.81	0.84	0.86	0.87	0.87	0.88	0.88	0.87	0.87	0.87	0.87	0.87
	50	0.55	0.6	0.71	0.76	0.78	0.79	0.79	0.79	0.79	0.79	0.78	0.78	-	-	-
	54.25	0.56	0.62	0.72	0.77	0.79	0.8	0.81	0.81	0.81	0.8	0.8	0.79	-	-	-
	61.25	0.55	0.6	0.71	0.76	0.78	0.79	0.79	0.79	0.79	0.79	0.78	0.78	-	-	-
	68.2	0.56	0.62	0.72	0.77	0.79	0.8	0.81	0.81	0.81	0.8	0.8	0.79	-	-	-
	77	0.55	0.6	0.71	0.76	0.78	0.79	0.79	0.79	0.79	0.79	0.78	0.78	-	-	-
	87.833	0.56	0.62	0.72	0.77	0.79	0.8	0.81	0.81	0.81	0.8	0.8	0.79	-	-	-
	99.167	0.55	0.6	0.71	0.76	0.78	0.79	0.79	0.79	0.79	0.79	0.78	0.78	-	-	-
	111.318	0.56	0.62	0.72	0.77	0.79	0.8	0.81	0.81	0.81	0.8	0.8	0.79	-	-	-
	125.682	0.55	0.6	0.71	0.76	0.78	0.79	0.79	0.79	0.79	0.79	0.78	0.78	-	-	-
	139.5	0.56	0.62	0.72	0.77	0.79	0.8	0.81	0.81	0.81	0.8	0.8	0.79	-	-	-
	157.5	0.55	0.6	0.71	0.76	0.78	0.79	0.79	0.79	0.79	0.79	0.78	0.78	-	-	-
183.786	0.56	0.62	0.72	0.77	0.79	0.8	0.81	0.81	0.81	0.8	0.8	0.79	-	-	-	
207.5	0.55	0.6	0.71	0.76	0.78	0.79	0.79	0.79	0.79	0.79	0.78	0.78	-	-	-	



		Output speeds n_2 [min ⁻¹]															
		I	1	5	10	16	25	32	40	63	100	160	250	400	630	800	
		η_A	$\eta_{c=1}$	$\eta_{c=1}$	$\eta_{c=1}$	$\eta_{c=1}$	$\eta_{c=1}$	$\eta_{c=1}$	$\eta_{c=1}$	$\eta_{c=1}$	$\eta_{c=1}$	$\eta_{c=1}$	$\eta_{c=1}$	$\eta_{c=1}$	$\eta_{c=1}$	$\eta_{c=1}$	
GSS05-2	5.639	0.71	0.79	0.81	0.85	0.87	0.89	0.9	0.9	0.91	0.91	0.91	0.91	0.9	0.9	0.9	
	7.733																
	9.042	0.67	0.75	0.79	0.83	0.86	0.87	0.88	0.88	0.89	0.89	0.88	0.88	0.88	0.88	-	
	9.897																
	10.827	0.71	0.79	0.81	0.85	0.87	0.89	0.9	0.9	0.91	0.91	0.91	0.91	0.9	0.9	0.9	
	12.4	0.67	0.75	0.79	0.83	0.86	0.87	0.88	0.88	0.89	0.89	0.88	0.88	0.88	0.88	-	
	13.81	0.71	0.79	0.81	0.85	0.87	0.89	0.9	0.9	0.91	0.91	0.91	0.91	0.9	0.9	0.9	
	15.869																
	17.36	0.67	0.75	0.79	0.83	0.86	0.87	0.88	0.88	0.89	0.89	0.88	0.88	0.88	0.88		
	20.417	0.55	0.62	0.74	0.79	0.8	0.81	0.81	0.81	0.81	0.81	0.81	0.81	0.81	-	-	
	22.143	0.67	0.75	0.79	0.83	0.86	0.87	0.88	0.88	0.89	0.89	0.88	0.88	0.88	0.88	0.88	
	24.8	0.57	0.63	0.75	0.79	0.81	0.82	0.82	0.83	0.83	0.82	0.82	0.82	0.82	-	-	
	27.125	0.67	0.75	0.79	0.83	0.86	0.87	0.88	0.88	0.89	0.89	0.88	0.88	0.88	0.88	0.88	
	31.738	0.57	0.63	0.75	0.79	0.81	0.82	0.82	0.83	0.83	0.82	0.82	0.82	0.82	-	-	
	35.306	0.67	0.75	0.79	0.83	0.86	0.87	0.88	0.88	0.89	0.89	0.88	0.88	0.88	0.88	0.88	
	39.2	0.55	0.62	0.74	0.79	0.8	0.81	0.81	0.81	0.81	0.81	0.81	0.81	0.81	-	-	
	43.917	0.67	0.75	0.79	0.83	0.86	0.87	0.88	0.88	0.89	0.89	0.88	0.88	0.88	0.88	0.88	
	50	0.55	0.62	0.74			0.8	0.81	0.81	0.81	0.81	0.81	0.81	0.81			
	54.25	0.57	0.63	0.75			0.81	0.82	0.82	0.83	0.83	0.82	0.82	0.82			-
	61.25	0.55	0.62	0.74			0.8	0.81	0.81	0.81	0.81	0.81	0.81	0.81			
	70.611	0.57	0.63	0.75			0.81	0.82	0.82	0.83	0.83	0.82	0.82	0.82			
	79.722	0.55	0.62	0.74			0.8	0.81	0.81	0.81	0.81	0.81	0.81	0.81			
	87.833	0.57	0.63	0.75			0.81	0.82	0.82	0.83	0.83	0.82	0.82	0.82			
	99.167	0.55	0.62	0.74	0.79		0.8	0.81	0.81	0.81	0.81	0.81	0.81	0.81	-	-	
	113.667	0.57	0.63	0.75			0.81	0.82	0.82	0.83	0.83	0.82	0.82	0.82			
	128.333	0.55	0.62	0.74			0.8	0.81	0.81	0.81	0.81	0.81	0.81	0.81			
	137.95	0.57	0.63	0.75			0.81	0.82	0.82	0.83	0.83	0.82	0.82	0.82			
	155.75	0.55	0.62	0.74			0.8	0.81	0.81	0.81	0.81	0.81	0.81	0.81			
176.313	0.57	0.63	0.75			0.81	0.82	0.82	0.83	0.83	0.82	0.82	0.82				
199.063	0.55	0.62	0.74			0.8	0.81	0.81	0.81	0.81	0.81	0.81	0.81				



Drive dimensioning

GSS efficiencies

		Output speeds n_2 [min ⁻¹]														
		I	1	5	10	16	25	32	40	63	100	160	250	400	630	800
		η_A	$\eta_{c=1}$	$\eta_{c=1}$	$\eta_{c=1}$	$\eta_{c=1}$	$\eta_{c=1}$	$\eta_{c=1}$	$\eta_{c=1}$	$\eta_{c=1}$	$\eta_{c=1}$	$\eta_{c=1}$	$\eta_{c=1}$	$\eta_{c=1}$	$\eta_{c=1}$	$\eta_{c=1}$
GSS05-3	125.476															
	153.708	0.67	0.75	0.79	0.83	0.86	0.87	0.88	0.88	0.89	0.89	0.88	0.88	0.88	0.88	
	193.233															
	222.133	0.55	0.62	0.74		0.8	0.81	0.81	0.81	0.81	0.81	0.81	0.81			
	250.952	0.57	0.63	0.75		0.81	0.82	0.82	0.83	0.83	0.82	0.82	0.82			
	283.333	0.55	0.62	0.74		0.8	0.81	0.81	0.81	0.81	0.81	0.81	0.81			
	307.417	0.57	0.63	0.75		0.81	0.82	0.82	0.83	0.83	0.82	0.82	0.82			
	347.083	0.55	0.62	0.74		0.8	0.81	0.81	0.81	0.81	0.81	0.81	0.81			
	386.467	0.57	0.63	0.75	0.79	0.81	0.82	0.82	0.83	0.83	0.82	0.82	0.82	-	-	
	436.333	0.55	0.62	0.74		0.8	0.81	0.81	0.81	0.81	0.81	0.81	0.81			
	497.722	0.57	0.63	0.75		0.81	0.82	0.82	0.83	0.83	0.82	0.82	0.82			
	561.944	0.55	0.62	0.74		0.8	0.81	0.81	0.81	0.81	0.81	0.81	0.81			
	630.803	0.57	0.63	0.75		0.81	0.82	0.82	0.83	0.83	0.82	0.82	0.82			
	712.197	0.55	0.62	0.74		0.8	0.81	0.81	0.81	0.81	0.81	0.81	0.81			



		Output speeds n_2 [min ⁻¹]																
		I	1	5	10	16	25	32	40	63	100	160	250	400	630	800		
		η_A	$\eta_{c=1}$	$\eta_{c=1}$	$\eta_{c=1}$	$\eta_{c=1}$	$\eta_{c=1}$	$\eta_{c=1}$	$\eta_{c=1}$	$\eta_{c=1}$	$\eta_{c=1}$	$\eta_{c=1}$	$\eta_{c=1}$	$\eta_{c=1}$	$\eta_{c=1}$	$\eta_{c=1}$		
GSS06-2	5.833	0.72	0.8	0.83	0.87	0.89	0.9	0.91	0.91	0.91	0.92	0.92	0.92	0.91	0.91	0.91		
	8	0.67	0.75	0.81	0.85	0.87	0.88	0.89	0.89	0.89	0.89	0.89	0.89	0.89	0.89	-		
	9.042	0.67	0.75	0.81	0.85	0.87	0.88	0.89	0.89	0.89	0.89	0.89	0.89	0.89	0.89	0.89	-	
	10.238	0.72	0.8	0.83	0.87	0.89	0.9	0.91	0.91	0.91	0.92	0.92	0.92	0.91	0.91	0.91		
	11.2	0.67	0.75	0.81	0.85	0.87	0.88	0.89	0.89	0.89	0.89	0.89	0.89	0.89	0.89	0.89	-	
	12.4	0.67	0.75	0.81	0.85	0.87	0.88	0.89	0.89	0.89	0.89	0.89	0.89	0.89	0.89	0.89	-	
	14.286	0.72	0.8	0.83	0.87	0.89	0.9	0.91	0.91	0.91	0.92	0.92	0.92	0.91	0.91	0.91	0.91	
	15.869	0.67	0.75	0.81	0.85	0.87	0.88	0.89	0.89	0.89	0.89	0.89	0.89	0.89	0.89	0.89	-	
	17.36	0.67	0.75	0.81	0.85	0.87	0.88	0.89	0.89	0.89	0.89	0.89	0.89	0.89	0.89	0.89	-	
	20.417	0.57	0.64	0.77	0.81	0.82	0.83	0.83	0.83	0.83	0.83	0.83	0.83	0.83	-	-	-	
	22.143	0.67	0.75	0.81	0.85	0.87	0.88	0.89	0.89	0.89	0.89	0.89	0.89	0.89	0.89	0.89	0.89	
	24.8	0.57	0.64	0.77	0.81	0.83	0.83	0.83	0.83	0.83	0.83	0.83	0.83	0.83	-	-	-	
	27.125	0.67	0.75	0.81	0.85	0.87	0.88	0.89	0.89	0.89	0.89	0.89	0.89	0.89	0.89	0.89	0.89	
	31.738	0.57	0.64	0.77	0.81	0.83	0.83	0.83	0.83	0.83	0.83	0.83	0.83	0.83	-	-	-	
	35.306	0.67	0.75	0.81	0.85	0.87	0.88	0.89	0.89	0.89	0.89	0.89	0.89	0.89	0.89	0.89	0.89	
	39.2	0.57	0.64	0.77	0.81	0.82	0.83	0.83	0.83	0.83	0.83	0.83	0.83	0.83	-	-	-	
	43.917	0.67	0.75	0.81	0.85	0.87	0.88	0.89	0.89	0.89	0.89	0.89	0.89	0.89	0.89	0.89	0.89	
	50						0.82											-
	54.25						0.83											-
	61.25						0.82											-
	70.611						0.83											-
	79.722						0.82											-
	87.833						0.83											-
	99.167	0.57	0.64	0.77	0.81		0.82	0.83	0.83	0.83	0.83	0.83	0.83	0.83	-	-	-	
	113.667						0.83											-
	128.333						0.82											-
137.95						0.83											-	
155.75						0.82											-	
174.375						0.83											-	
196.875						0.82											-	



Drive dimensioning

GSS efficiencies

		Output speeds n_2 [min ⁻¹]														
		I	1	5	10	16	25	32	40	63	100	160	250	400	630	800
		η_A	$\eta_{c=1}$	$\eta_{c=1}$	$\eta_{c=1}$	$\eta_{c=1}$	$\eta_{c=1}$	$\eta_{c=1}$	$\eta_{c=1}$	$\eta_{c=1}$	$\eta_{c=1}$	$\eta_{c=1}$	$\eta_{c=1}$	$\eta_{c=1}$	$\eta_{c=1}$	$\eta_{c=1}$
GSS06-3	126.531					0.83										
	142.857					0.82										
	155					0.83										
	175					0.82										
	194.857					0.83										
	220					0.82										
	238.7					0.83										
	269.5					0.82										
	310.689					0.83										
	350.778					0.82										
	386.467					0.83										
	436.333	0.57	0.64	0.77	0.81	0.82	0.83	0.83	0.83	0.83	0.83	0.83	0.83	-	-	-
	497.722					0.83										
	561.944					0.82										
	630.803					0.83										
	712.197					0.82										
	816.333					0.83										
	921.667					0.82										
	1023					0.83										
	1155					0.82										
1241.55					0.83											
1401.75					0.82											
1635.693					0.83											
1846.75					0.82											



	Output speeds n_2 [min ⁻¹]														
	I	1	5	10	16	25	32	40	63	100	160	250	400	630	800
	η_A	$\eta_{c=1}$	$\eta_{c=1}$	$\eta_{c=1}$	$\eta_{c=1}$	$\eta_{c=1}$	$\eta_{c=1}$	$\eta_{c=1}$	$\eta_{c=1}$	$\eta_{c=1}$	$\eta_{c=1}$	$\eta_{c=1}$	$\eta_{c=1}$	$\eta_{c=1}$	$\eta_{c=1}$
GSS07-2	5.862	0.74	0.82	0.86	0.89	0.91	0.92	0.92	0.92	0.92	0.92	0.92	0.92	0.92	0.92
	8.125														
	9.086	0.69	0.77	0.84	0.88	0.89	0.9	0.9	0.9	0.9	0.9	0.9	0.9	0.9	-
	10														
	11.2	0.74	0.82	0.86	0.89	0.91	0.92	0.92	0.92	0.92	0.92	0.92	0.92	0.92	0.92
	12.594	0.69	0.77	0.84	0.88	0.89	0.9	0.9	0.9	0.9	0.9	0.9	0.9	0.9	0.9
	14.286	0.74	0.82	0.86	0.89	0.91	0.92	0.92	0.92	0.92	0.92	0.92	0.92	0.92	0.92
	15.5														
	17.36	0.69	0.77	0.84	0.88	0.89	0.9	0.9	0.9	0.9	0.9	0.9	0.9	0.9	-
	20.517	0.6	0.67	0.81	0.84	0.84	0.85	0.85	0.85	0.85	0.85	0.85	0.85	-	-
	22.143	0.69	0.77	0.84	0.88	0.89	0.9	0.9	0.9	0.9	0.9	0.9	0.9	0.9	0.9
	25.188	0.6	0.66	0.8	0.84	0.85	0.85	0.85	0.85	0.85	0.85	0.85	0.85	-	-
	27.125	0.69	0.77	0.84	0.88	0.89	0.9	0.9	0.9	0.9	0.9	0.9	0.9	0.9	0.9
	31	0.6	0.66	0.8	0.84	0.85	0.85	0.85	0.85	0.85	0.85	0.85	0.85	-	-
	35.306	0.69	0.77	0.84	0.88	0.89	0.9	0.9	0.9	0.9	0.9	0.9	0.9	0.9	0.9
	39.2	0.6	0.67	0.81	0.84	0.84	0.85	0.85	0.85	0.85	0.85	0.85	0.85	-	-
	43.271	0.69	0.77	0.84	0.88	0.89	0.9	0.9	0.9	0.9	0.9	0.9	0.9	0.9	0.9
	50		0.67	0.81		0.84									
	54.25		0.66	0.8		0.85									-
	61.25		0.67	0.81		0.84									
	70.611		0.66	0.8		0.85									
	79.722		0.67	0.81		0.84									
	86.542		0.66	0.8		0.85									
	97.708	0.6	0.67	0.81	0.84	0.84	0.85	0.85	0.85	0.85	0.85	0.85	0.85	-	-
	113.667		0.66	0.8		0.85									
	128.333		0.67	0.81		0.84									
	137.95		0.66	0.8		0.85									
	155.75		0.67	0.81		0.84									
174.375		0.66	0.8		0.85										
196.875		0.67	0.81		0.84										



Drive dimensioning

GSS efficiencies

		Output speeds n_2 [min ⁻¹]														
		I	1	5	10	16	25	32	40	63	100	160	250	400	630	800
		η_A	$\eta_{c=1}$	$\eta_{c=1}$	$\eta_{c=1}$	$\eta_{c=1}$	$\eta_{c=1}$	$\eta_{c=1}$	$\eta_{c=1}$	$\eta_{c=1}$	$\eta_{c=1}$	$\eta_{c=1}$	$\eta_{c=1}$	$\eta_{c=1}$	$\eta_{c=1}$	$\eta_{c=1}$
GSS07-3	126.531	0.6	0.66	0.8	0.84	0.85	0.85	0.85	0.85	0.85	0.85	0.85	0.85	-	-	-
	142.857		0.67	0.81		0.84										
	155		0.66	0.8		0.85										
	175		0.67	0.81		0.84										
	201.746		0.66	0.8		0.85										
	227.778		0.67	0.81		0.84										
	247.139		0.66	0.8		0.85										
	279.028		0.67	0.81		0.84										
	321.673		0.66	0.8		0.85										
	363.179		0.67	0.81		0.84										
	394.245		0.66	0.8		0.85										
	445.116		0.67	0.81		0.84										
	490.403		0.66	0.8		0.85										
	553.681		0.67	0.81		0.84										
	634.639		0.66	0.8		0.85										
	716.528		0.67	0.81		0.84										
	833.556		0.66	0.8		0.85										
	941.111		0.67	0.81		0.84										
	1011.633		0.66	0.8		0.85										
	1142.167		0.67	0.81		0.84										
1227.755	0.66	0.8	0.85													
1386.175	0.67	0.81	0.84													
1569.181	0.66	0.8	0.85													
1771.656	0.67	0.81	0.84													



General data

Gearbox type	GST	GFL	GKR	GKS	GSS
Housing					
Design	Cuboid				
Material	Aluminium/grey cast iron				
Solid shaft					
Design	With keyway in accordance with DIN 6885 Centring hole in accordance with DIN 332, Part 2				
Tolerance	k6 ($d \leq 50$ mm) m6 ($d > 50$ mm)				
Material	Tempering steel C45 or 42CrMo4				
Hollow shaft					
Design	-	Hollow shaft (H): with keyway Hollow shaft with shrink disc (S): smooth			
Tolerance	-	Bore measured in accordance with ISO H7 with plug gauge			
Material	-	Tempering steel C45			
Geared parts					
Design	Optimised tooth flanks and profile geometry; ground tooth flanks				
Material	Case-hardened steel			Case-hardened steel, worm gear bronze	
Shaft-hub joint					
Design	1st stage/pre-stage: friction-type connection (= 2nd, 3rd or 4th stage): friction-type or positive-fit				
Shaft sealing rings					
Design	With dust lip				
Material	NB/FP (Viton)				
Bearing					
Design	Ball bearings/tapered-roller bearings depending on frame size and design				
Lubricants					
Design	In accordance with DIN 51502				
Fill volumes	Depending on the mounting position (see Operating Instructions)				
Mechanical efficiency					
At rated torque	$0.95 \leq \eta \leq 0.98$	$0.95 \leq \eta \leq 0.96$	$0.93 \leq \eta \leq 0.95$	$0.79 \leq \eta \leq 0.92$ ▶ depending on ratio ▶ when $n_1 = 1400 \text{ min}^{-1}$ ▶ gearbox at operating temperature and gearing run in	
Noises	Does not exceed the emission values specified in VDI Guideline 2159				
Enclosure					
Design	IP55 and IP65				

General data

Gearbox type	GPA
Housing	
Design	Cuboid
Material	Cast iron with nodular graphite
Solid shaft	
Design	Smooth without keyway Centring hole in accordance with DIN 332, Part 2
Tolerance	k6
Material	Tempering steel C45
Geared parts	
Design	Spur toothing, optimised tooth flanks and profile geometry
Planet pinions + sun wheel	Design: case-hardened and tooth flanks ground Material: case-hardened steel 17 Cr Ni Mo 6
Internal gearing	Design: shaped or broached Material: ductile cast iron EN-GJS-700-2
Ratios	Design: all ratios are mathematically exact
Shaft-hub joint	
	Positive-fit with special splined shaft profile
Shaft sealing rings	
Design	With dust lip
Material	FP (Viton)
Bearing	
Design	Ball bearings/tapered-roller bearings/needle bearings depending on frame size
Lubricants	
Design	In accordance with DIN 51502
Fill volumes	Depending on the mounting position (see Operating Instructions)
Mechanical efficiency	
At rated torque	$0.95 \leq \eta \leq 0.98$
Noises	
	Does not exceed the emission values specified in VDI Guideline 2159
Enclosure	
Design	IP54 and IP65



Ventilation

Gearboxes without ventilation

Ventilation is not required for the following gearboxes:

GST03/04

GFL04

GPA00...05

GKR03...05

GKS04

GSS04

Gearboxes that can be fitted with optional ventilation

If you are using these gearboxes, in most cases you will not need to provide special means of ventilation. In borderline cases, e.g. at input speeds $> 2000 \text{ min}^{-1}$, we recommend the use of breather elements, which can be purchased separately.

GST05

GFL05

GKS05

Gearboxes with ventilation

The following gearboxes are supplied with breather elements as standard:

GST06...14

GFL06...14

GKR06

GKS06...14

GSS05 - 07

Special precautions for mounting position C (motor on top)

For gearbox sizes G□□09...14 in this mounting position, we recommend the use of an oil compensation reservoir. This can be purchased separately. Depending on the gearbox type, you can find illustrations and special precautions under ventilation G□□ [⊗].

It is not required at high ratios or low input speeds. Please contact Lenze in such cases.

Lubricants

Lenze gearboxes and geared motors are ready for operation on delivery and are filled with lubricants that are specific to both the drive and the design. The mounting position and design specified in the order are decisive factors in choosing the volume of lubricant.

The lubricants listed in the lubricant table are approved for use in Lenze drives.

Lubricant table

- ▶ Please contact us you are working at ambient temperatures < -20°C or > +40°C.

Lubricants in accordance with DIN 51517-3: CLP-ISO 12925-1: CKC/CKD	CLP HC 320	CLP HC 150	CLP HC 220 USDA H1	CLP PG 460	CLP PG 220 USDA H1
GST / GFL / GKR / GKS	•		•		
GPA		•			
GSS					•
Ambient temperature [°C]	-25 ... +50		-20 ... +40		
Specification	Synthetic oil (synthetic hydrocarbon/poly-alpha-olefin oil)			Synthetic oil (polyglycol)	
Note			For the foodstuffs processing industry.	Not mixable with other oil types.	For the foodstuffs processing industry. Not mixable with other oil types.
Change interval	25000 operating hours		16000 operating hours	25000 operating hours	16000 operating hours
	After no more than three years (oil temperature 70 - 80°C)				
Fuchs	Fuchs Renolin Unisyn CLP 320				
Klüber	Klübersynth GEM4-320		Klüberoil 4 UH1-220 N	Klübersynth GH 6-460	
Shell	Shell Omala Oil HD 320		Shell Cassida Fluid GL 220	Shell Tivela S 460	Shell Cassida Fluid WG 220
Mobil			Mobil SHC 629		

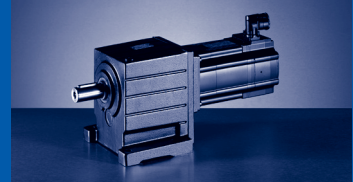

Permissible radial force

$$Fr_{zul} = \min(f_w \times f_\alpha \times Fr_{Tab}; f_w \times Fr_{max})$$

At Fr and $Fa \neq 0$ please contact your Lenze sales office.

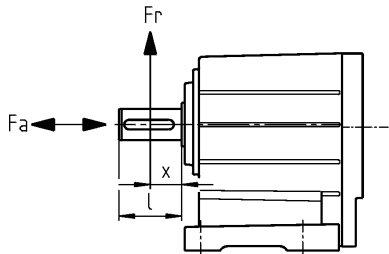

Permissible axial force

$$Fa_{zul} = Fa_{Tab} \text{ at } Fr = 0$$

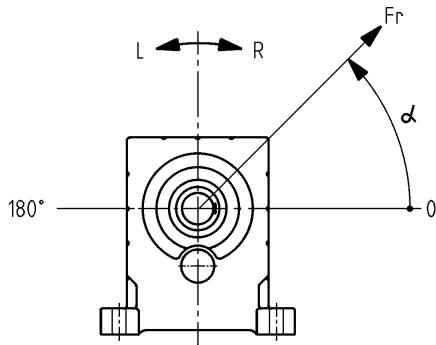

Effective direction factor f_α at output shaft

GST03-2

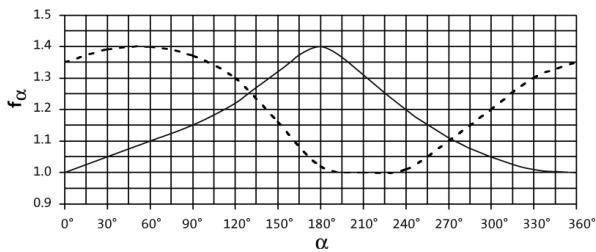

GST04...09-1

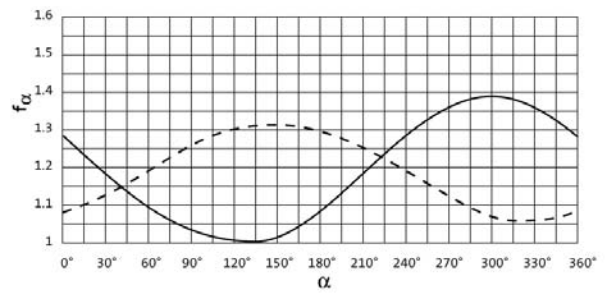

GST04...09-2, 3

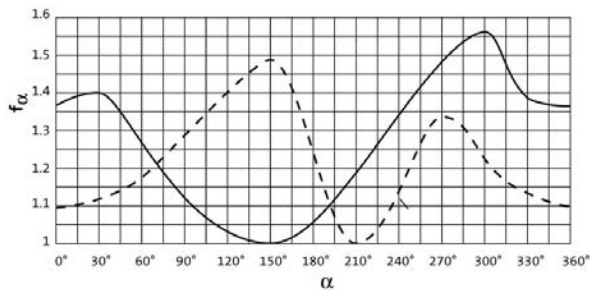

GST11...14-2, 3

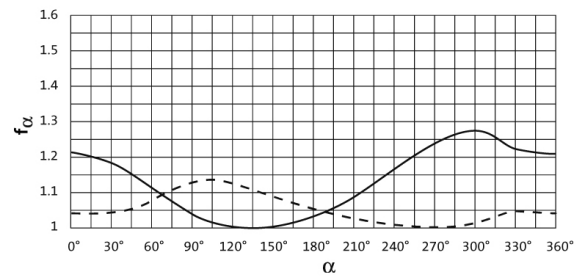

—— Direction of rotation R

- - - Direction of rotation L

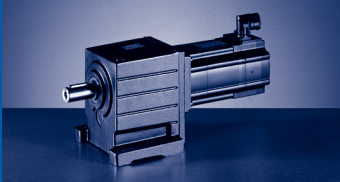

GST [N]

Additional load factor f_w at output shaft

GST03-2

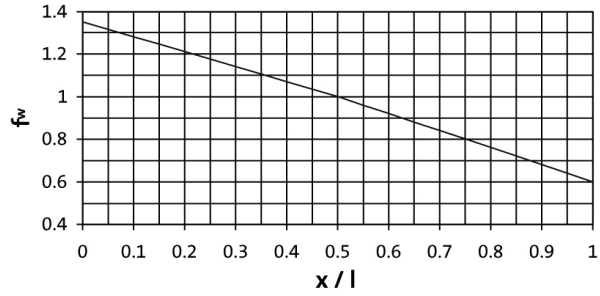

GST04...14-1, 2, 3

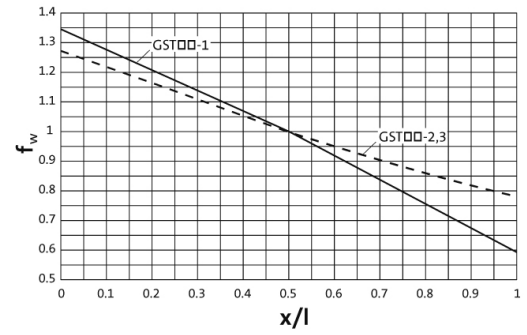

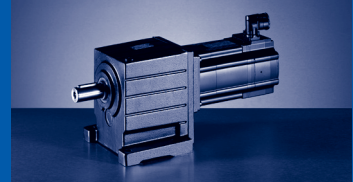

GST□□-1

Solid shaft (V□□)										
Application of force F_r : centre of shaft journal ($x = l/2$)										
$F_{a_{Tab}}$ only valid for $F_r = 0$										
	GST04-1		GST05-1		GST06-1		GST07-1		GST09-1	
n_2 [min ⁻¹]	$F_{r_{Tab}}$ [N]	$F_{a_{Tab}}$ [N]	$F_{r_{Tab}}$ [N]	$F_{a_{Tab}}$ [N]	$F_{r_{Tab}}$ [N]	$F_{a_{Tab}}$ [N]	$F_{r_{Tab}}$ [N]	$F_{a_{Tab}}$ [N]	$F_{r_{Tab}}$ [N]	$F_{a_{Tab}}$ [N]
2500	100	600	100	800	200	900	700	1200	1750	2500
1600	180	800	250	1100	600	1200	1000	1600	2200	3400
1000	440	1000	550	1400	800	1500	1200	2000	2500	4300
600	600	1300	750	2000	800	2000	1300	2700	2500	5700
400	850	1400	1400	2000	1100	2500	1900	3300	3500	6800
200	1050	1400	2000	2000	2200	2500	3000	3700	6200	7000
125	1050	1400	2300	2000	2900	2500	3900	3700	7900	7000
80	1050	1400	2300	2000	3500	2500	4700	3700	9000	7000
≤ 50	1050	1400	2300	2000	3500	2500	5300	3700	9500	7000
$F_{r_{max}}$	1050	-	2300	-	3500	-	5300	-	9500	-

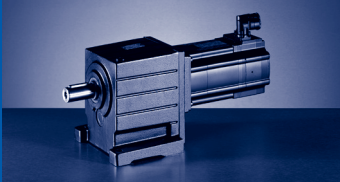

GST [N]

GST□□-2 / 3 with standard bearings

		Solid shaft (V□□) Application of force Fr: centre of shaft journal (x = l/2) Fa _{Tab} only valid for Fr = 0															
		GST03-2		GST04-2		GST05-2/3		GST06-2/3		GST07-2/3		GST09-2/3		GST11-2/3		GST14-2/3	
n ₂ [min ⁻¹]	Fr _{Tab} [N]	Fa _{Tab} [N]	Fr _{Tab} [N]	Fa _{Tab} [N]	Fr _{Tab} [N]	Fa _{Tab} [N]	Fr _{Tab} [N]	Fa _{Tab} [N]	Fr _{Tab} [N]	Fa _{Tab} [N]	Fr _{Tab} [N]	Fa _{Tab} [N]	Fr _{Tab} [N]	Fa _{Tab} [N]	Fr _{Tab} [N]	Fa _{Tab} [N]	
1000	100	300	730	600	1150	1200	140	500	140	1100	1500	1300	11500	5700	16600	9000	
630	300	400	950	800	1500	1600	750	600	2050	1500	1950	1800	14400	7600	20700	12000	
400	630	600	1250	1100	1950	2000	2350	850	3400	1900	6800	2300	17000	9500	24000	15000	
250	710	700	1450	1300	2200	2300	2600	900	3800	2200	7600	2800	19000	10000	27000	16000	
160	800	800	1700	1650	2600	2650	3100	1250	4500	2900	9400	4000	21000	11000	31000	18000	
100	920	900	2100	2000	3000	3100	3600	1800	5400	3900	11500	5600	21000	14000	36000	20000	
63	1100	1000	2500	2000	3500	3600	4300	2600	6400	5300	11500	8100	21000	16000	39000	20000	
40	1400	1000	2650	2000	3800	3600	4350	3600	7600	7000	11500	11000	21000	16000	40000	20000	
25	1500	1000	2650	2000	3900	3600	4350	4800	9100	7000	11500	12000	21000	16000	40000	20000	
≤ 16	1500	1000	2650	2000	3900	3600	4350	4800	9500	7000	11500	12000	21000	16000	40000	20000	
Fr _{max}	1500	-	2650	-	3900	-	4350	-	9500	-	11500	-	21000	-	40000	-	

GST□□-2/3 with reinforced bearings

		Solid shaft (V□□) Application of force Fr: centre of shaft journal (x = l/2) Fa _{Tab} only valid for Fr = 0									
		GST04-2		GST05-2/3		GST06-2/3		GST07-2/3		GST09-2/3	
n ₂ [min ⁻¹]	Fr _{Tab} [N]	Fa _{Tab} [N]	Fr _{Tab} [N]	Fa _{Tab} [N]	Fr _{Tab} [N]	Fa _{Tab} [N]	Fr _{Tab} [N]	Fa _{Tab} [N]	Fr _{Tab} [N]	Fa _{Tab} [N]	
1000	1900	1000	3350	2100	4250	2100	5650	3300	11300	4800	
630	2350	1300	3950	2800	5100	2800	6850	4400	14000	6400	
400	2850	1700	4900	3600	6300	3500	8500	5500	16500	8000	
250	3150	1900	5400	3900	7000	3600	9500	6100	17000	9000	
160	3550	2200	5400	4300	7700	4200	10500	7100	17000	10500	
100	3750	2500	5400	4500	7700	4900	12500	8300	17000	12500	
63	3750	2500	5400	4500	7700	5700	13000	9000	17000	14000	
40	3750	2500	5400	4500	7700	5700	13000	9000	17000	14000	
25	3750	2500	5400	4500	7700	5700	13000	9000	17000	14000	
≤ 16	3750	2500	5400	4500	7700	5700	13000	9000	17000	14000	
Fr _{max}	3750	-	5400	-	7700	-	13000	-	17000	-	

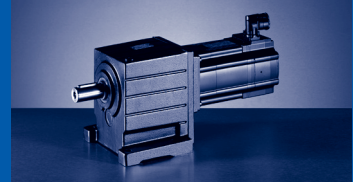

Output backlash in angular minutes

GST03-2

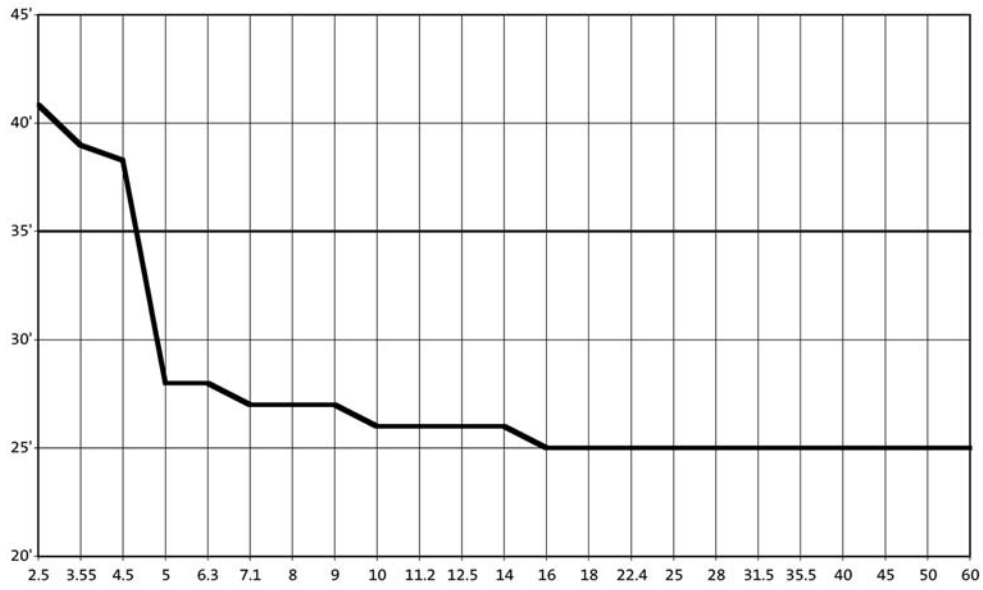

Ratio

GST04...09-1

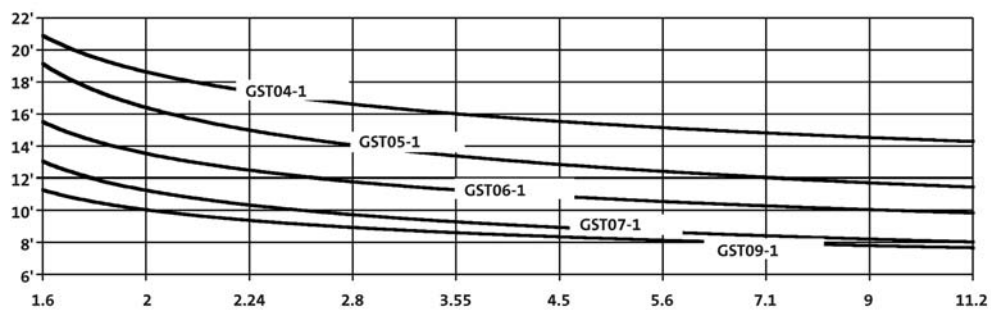

Ratio

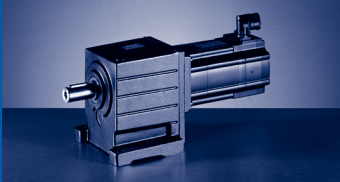

Output backlash in angular minutes

GST04...14-2

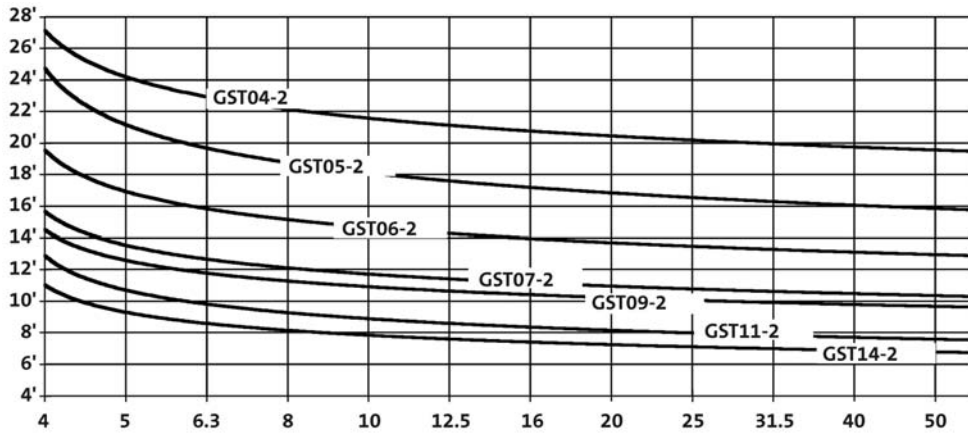

Ratio

GST05...14-3

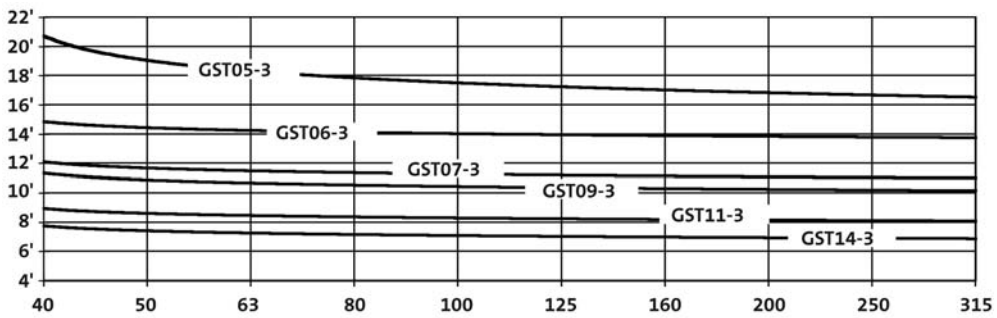

Ratio

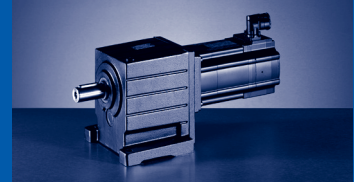

Position of ventilation, sealing elements and oil control

GST05...09-1

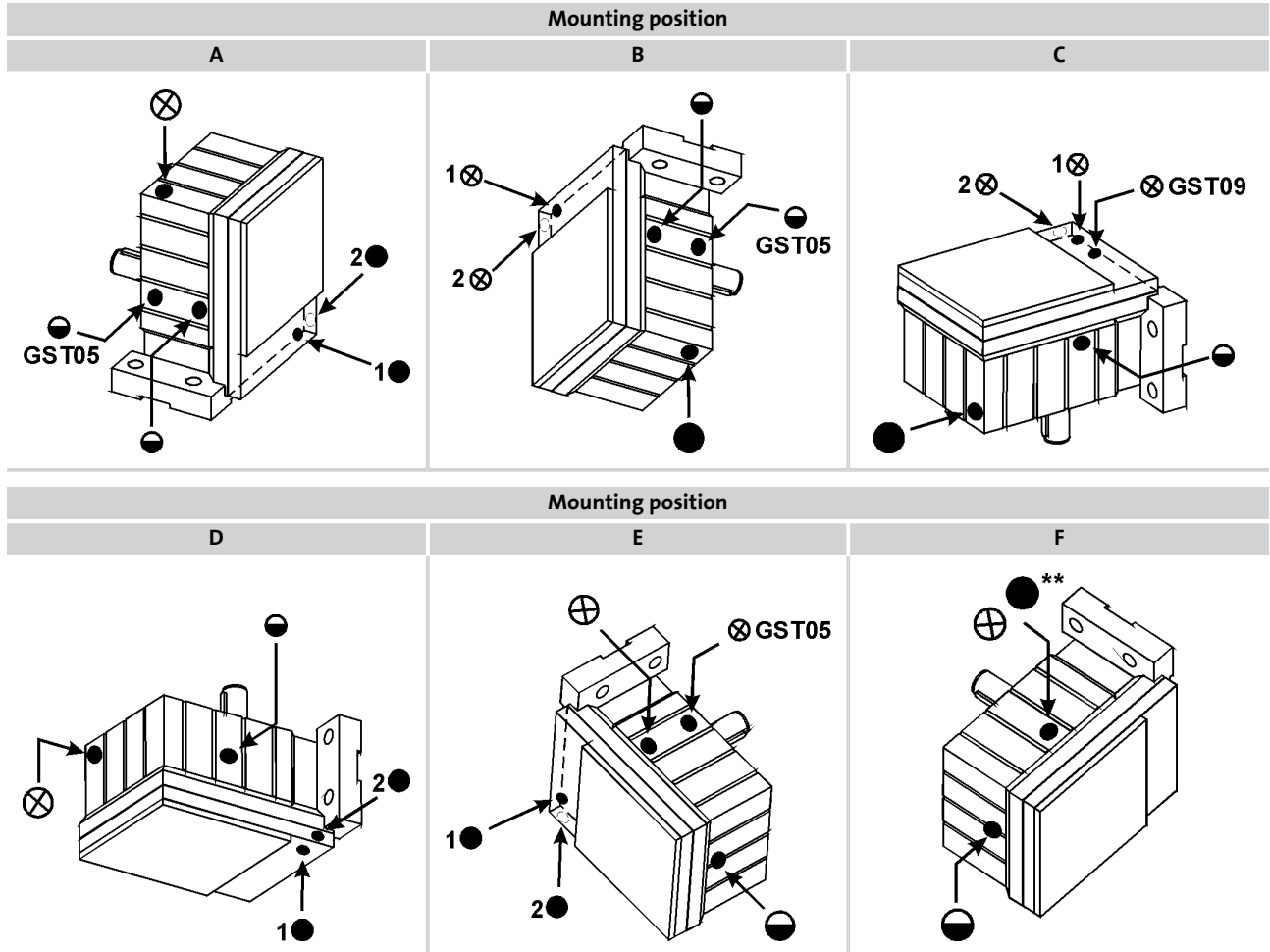

- ⊗ Ventilation/oil filler plug
- Oil drain plug
- ⊖ Oil control plug
- * On both sides
- ** Opposite

Pos.1 standard
 Pos.2 only on GST05-1A □□□ 14LC□□

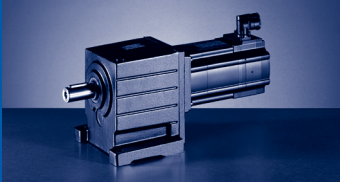

Position of ventilation, sealing elements and oil control

GST05...14-2

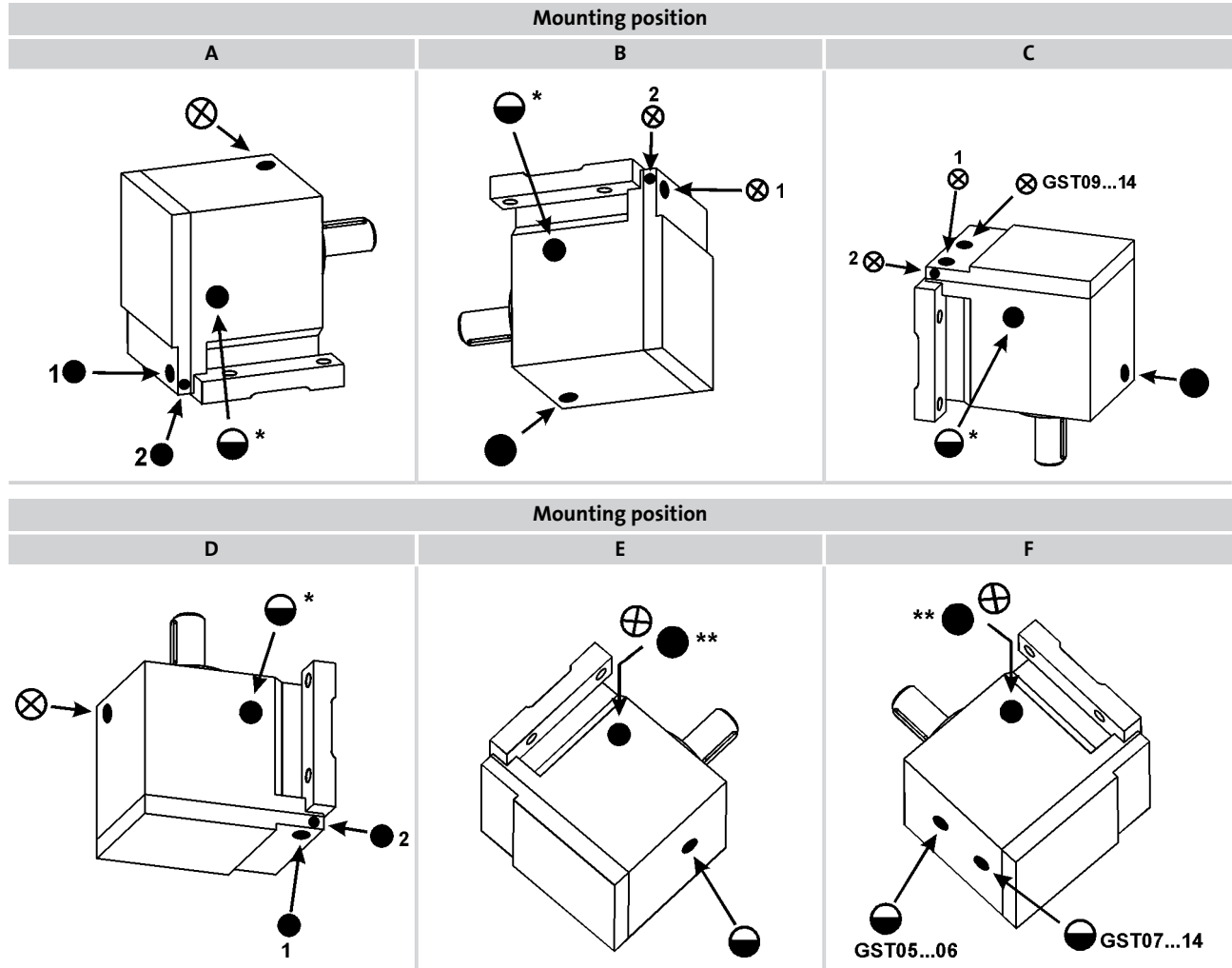

- ⊗ Ventilation/oil filler plug
- Oil drain plug
- Oil control plug
- * On both sides
- ** Opposite

Pos.1 standard
 Pos.2 only on GST05-2A □□□ 14LC□□



Position of ventilation, sealing elements and oil control

GST05...14-3

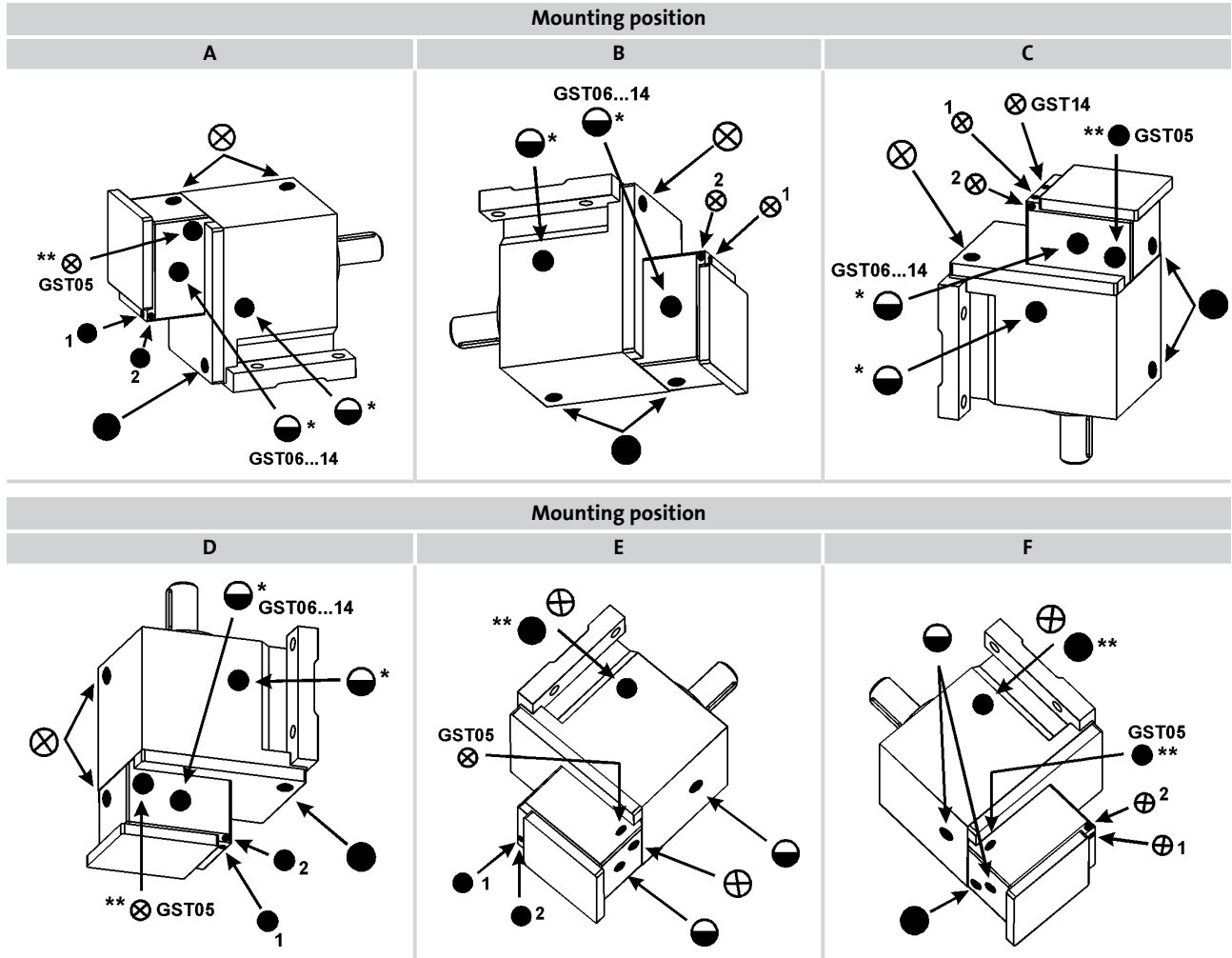

- ⊗ Ventilation/oil filler plug
- Oil drain plug
- ◐ Oil control plug
- * On both sides
- ** Opposite

Pos.1 standard
 Pos.2 only on GST07-3A □□□ 14LC□□

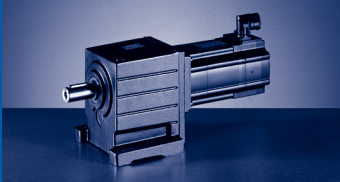

Compensation reservoir for mounting position C

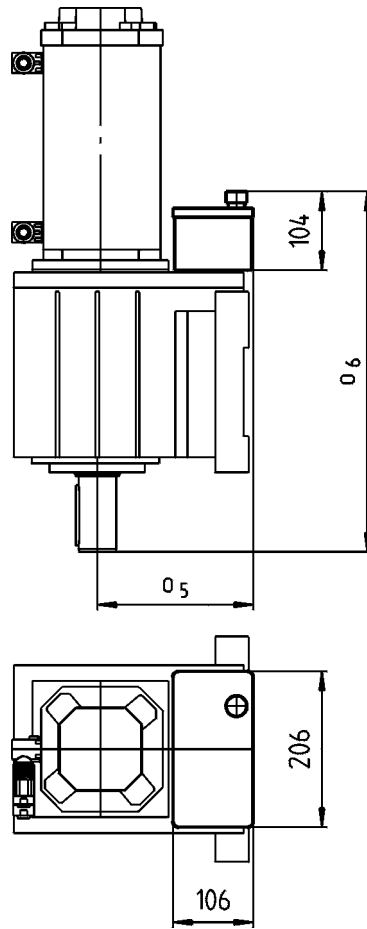

GST□□-2A...		14LC□□ ¹⁾	17NC□□ ¹⁾	19SC□□ ¹⁾	21XC□□ ¹⁾	GST□□-2S...		12□C□□	14□C□□	19□C□□
GST09...	o ₅	206		226	245	GST09...	o ₅	206		245
	o ₆	477					o ₆	477		
GST11...	o ₅	208		230	254	GST11...	o ₅	208		254
	o ₆	536		540			o ₆	536		540
GST14...	o ₅			252	282	GST14...	o ₅			282
	o ₆			640			o ₆			640

¹⁾ Connector/terminal box position 4 is not permitted.

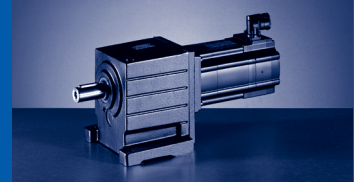

GST□□-1S VBR...RSO B0

	06C C41	06F C41	06I C41	09D C41	09F C38	09H C41	09L C41	12D C20	12D C41	12H C15	12H C30	12H C35	12L C20	12L C41
GST04...	7		8	10		11	13							
GST05...	9		10	12		13		15			18			21
GST06...	14		15	16	17	18	20	19			23			26
GST07...				26	27	28	30	29			32			35
GST09...								45			48			51

	14D C15	14D C36	14H C15	14H C32	14L C15	14L C32	14P C14	14P C32	19F C14	19F C30	19J C14	19J C30	19P C14	19P C30
GST06...	25		29		34		39							
GST07...	34		39		44		49		51		58			68
GST09...	50		55		59		64		66		73			83

GST□□-1S VCR...RSO B0

	06C C41	06F C41	06I C41	09D C41	09F C38	09H C41	09L C41	12D C20	12D C41	12H C15	12H C30	12H C35	12L C20	12L C41
GST04...	6		7	9	10	11	13							
GST05...	8		9	11		12		14			17			20
GST06...	12		13	15	16			18			21			24
GST07...				23	24	25	27	26			29			32
GST09...								40			43			47

	14D C15	14D C36	14H C15	14H C32	14L C15	14L C32	14P C14	14P C32	19F C14	19F C30	19J C14	19J C30	19P C14	19P C30
GST06...	23		28		32		37							
GST07...	31		36		41		46		48		55			65
GST09...	45		50		55		60		62		69			79

Note additional weights.
Weights in [kg] with oil capacity for mounting position A, all given as approximate values

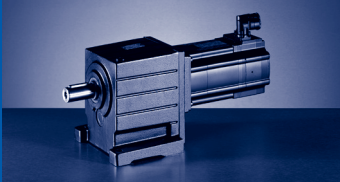

GST [kg]

GST□□-2S VAR/VBR...RSO B0

	06C C41	06F C41	06I C41	09D C41	09F C38	09H C41	09L C41	12D C20	12D C41	12H C15	12H C30	12H C35	12L C20	12L C41
GST03...	4	5	6											
GST04...	9		10	11	12	13	15							
GST05...	12	13		15	16	17	19	18		22			25	
GST06...	20	21		23	24	25		26		29			32	
GST07...				38	39	40	42	41		44			48	
GST09...								69		72			76	
	14D C15	14D C36	14H C15	14H C32	14L C15	14L C32	14P C14	14P C32	19F C14	19F C30	19J C14	19J C30	19P C14	19P C30
GST06...	31		36		40		45							
GST07...	47		51		56		61		63		70		80	
GST09...	75		79		84		89		91		98		108	
GST11...	121		126		130		135		137		144		154	
GST14...								227		234		244		

GST□□-2S VCR...RSO B0

	06C C41	06F C41	06I C41	09D C41	09F C38	09H C41	09L C41	12D C20	12D C41	12H C15	12H C30	12H C35	12L C20	12L C41
GST03...	4	5												
GST04...	8		9	11	12	13	14							
GST05...	11	12		14		15		17		20			23	
GST06...	18	19		20	21	22	24	23		26			29	
GST07...				34	35	36		37		40			43	
GST09...								61		64			67	
	14D C15	14D C36	14H C15	14H C32	14L C15	14L C32	14P C14	14P C32	19F C14	19F C30	19J C14	19J C30	19P C14	19P C30
GST06...	28		33		38		42							
GST07...	42		47		52		56		59		66		76	
GST09...	66		71		75		80		82		89		99	
GST11...	106		111		115		120		122		129		139	
GST14...								199		206		216		

Note additional weights.

Weights in [kg] with oil capacity for mounting position A, all given as approximate values

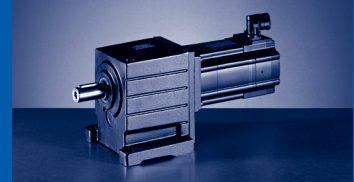

GST□□-3S VAR/VBR...RSO B0

	06C C41	06F C41	06I C41	09D C41	09F C38	09H C41	09L C41	12D C20	12D C41	12H C15	12H C30	12H C35	12L C20	12L C41
GST05...	15		16	18		19	21							
GST06...	25		26	28		29	31							
GST07...	43		44	45	46	47	49			52		55		
GST09...	75	76		78	79	80	82	81		84		87		
GST11...				133		134	136			139		142		
GST14...								243		246		249		

	14D C15	14D C36	14H C15	14H C32	14L C15	14L C32	14P C14	14P C32	19F C14	19F C30	19J C14	19J C30	19P C14	19P C30
GST09...	86		91		95		100							
GST11...	141		146		150		155		158		165		175	
GST14...	248		253		257		262		264		271		281	

GST□□-3S VCR...RSO B0

	06C C41	06F C41	06I C41	09D C41	09F C38	09H C41	09L C41	12D C20	12D C41	12H C15	12H C30	12H C35	12L C20	12L C41
GST05...	13		14	16	17	18	20							
GST06...	22		23	25	26	27	28							
GST07...	38	39		41	42	43	45	44		47		51		
GST09...	67		68	69	70	71	73	72		76		79		
GST11...				118	119		121			124		127		
GST14...								215		218		221		

	14D C15	14D C36	14H C15	14H C32	14L C15	14L C32	14P C14	14P C32	19F C14	19F C30	19J C14	19J C30	19P C14	19P C30
GST09...	78		82		87		92							
GST11...	126		131		135		140		143		150		160	
GST14...	220		225		229		234		236		243		253	

Note additional weights.
Weights in [kg] with oil capacity for mounting position A, all given as approximate values

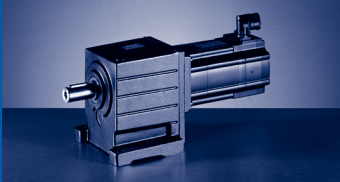

GST [kg]

GST□□-1A VBR...RSO B0

	10I C40 ...S00	13I C41 ...S00	13I C34 ...F10	14L C20 ...S00	14L C41 ...S00	14L C16 ...F10	14L C35 ...F10	17N C23 ...S00	17N C41 ...S00
GST04...	10	15	16						
GST05...	14	18	20	24		26			
GST06...	18	22	24	29		30		36	
GST07...	28	32	33	38		40		45	
GST09...				52		54		60	

	17N C17 ...F10	17N C35 ...F10	19S C23 ...S00	19S C42 ...S00	19S C17 ...F10	19S C35 ...F10	21X C25 ...S00	21X C42 ...S00	21X C17 ...F10	21X C35 ...F10
GST06...	39									
GST07...	48		69		72		86		89	
GST09...	63		83		86		101		104	

GST□□-1A VCR...RSO B0

	10I C40 ...S00	13I C41 ...S00	13I C34 ...F10	14L C20 ...S00	14L C41 ...S00	14L C16 ...F10	14L C35 ...F10	17N C23 ...S00	17N C41 ...S00
GST04...	10	14	16						
GST05...	13	17	19	23		25			
GST06...	17	21	22	27		29		35	
GST07...	25	29	30	35		36		42	
GST09...				48		50		56	

	17N C17 ...F10	17N C35 ...F10	19S C23 ...S00	19S C42 ...S00	19S C17 ...F10	19S C35 ...F10	21X C25 ...S00	21X C42 ...S00	21X C17 ...F10	21X C35 ...F10
GST06...	37									
GST07...	45		66		69		83		86	
GST09...	58		78		82		96		100	

Note additional weights.

Weights in [kg] with oil capacity for mounting position A, all given as approximate values

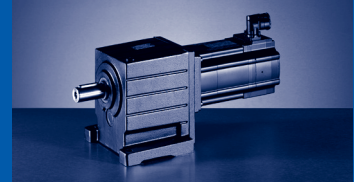

GST□□-2A VAR/VBR...RSO B0

	10I C40 ...S00	13I C41 ...S00	13I C34 ...F10	14L C20 ...S00	14L C41 ...S00	14L C16 ...F10	14L C35 ...F10	17N C23 ...S00	17N C41 ...S00
GST04...	12	17	18						
GST05...	18	22	23		27		29		
GST06...	25	29	30		35		37		43
GST07...	40	44	46		50		52		58
GST09...					77		79		85
GST11...					123		125		131
GST14...									

	17N C17 ...F10	17N C35 ...F10	19S C23 ...S00	19S C42 ...S00	19S C17 ...F10	19S C35 ...F10	21X C25 ...S00	21X C42 ...S00	21X C17 ...F10	21X C35 ...F10
GST06...	45									
GST07...	60		81		84		98		101	
GST09...	87		107		111		125		129	
GST11...	133		153		156		170		173	
GST14...			245		248		259		263	

GST□□-2A VCR...RSO B0

	10I C40 ...S00	13I C41 ...S00	13I C34 ...F10	14L C20 ...S00	14L C41 ...S00	14L C16 ...F10	14L C35 ...F10	17N C23 ...S00	17N C41 ...S00
GST04...	12	16	18						
GST05...	16	20	22		26		28		
GST06...	22	26	28		32		34		40
GST07...	36	40	41		45		47		53
GST09...					68		70		76
GST11...					108		110		116
GST14...									

	17N C17 ...F10	17N C35 ...F10	19S C23 ...S00	19S C42 ...S00	19S C17 ...F10	19S C35 ...F10	21X C25 ...S00	21X C42 ...S00	21X C17 ...F10	21X C35 ...F10
GST06...	43									
GST07...	56		77		80		93		97	
GST09...	79		99		102		117		120	
GST11...	118		138		141		155		158	
GST14...			217		220		231		235	

Note additional weights.

Weights in [kg] with oil capacity for mounting position A, all given as approximate values

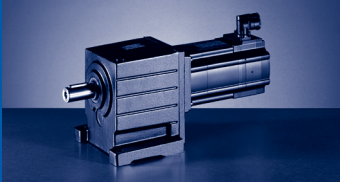

GST [kg]

GST□□-3A VAR/VBR...RSO B0

	10I C40 ...S00	13I C41 ...S00	13I C34 ...F10	14L C20 ...S00	14L C41 ...S00	14L C16 ...F10	14L C35 ...F10	17N C23 ...S00	17N C41 ...S00
GST05...	18	23	25						
GST06...	28	33	35						
GST07...	48	52	54	58		60			
GST09...	80	84	85	90		92		98	
GST11...	134	138	140	144		146		152	
GST14...				250		252		258	

	17N C17 ...F10	17N C35 ...F10	19S C23 ...S00	19S C42 ...S00	19S C17 ...F10	19S C35 ...F10	21X C25 ...S00	21X C42 ...S00	21X C17 ...F10	21X C35 ...F10
GST09...	100									
GST11...	155		175		179		192		196	
GST14...	261		281		284		299		302	

GST□□-3A VCR...RSO B0

	10I C40 ...S00	13I C41 ...S00	13I C34 ...F10	14L C20 ...S00	14L C41 ...S00	14L C16 ...F10	14L C35 ...F10	17N C23 ...S00	17N C41 ...S00
GST05...	17	21	23						
GST06...	26	30	32						
GST07...	44	48	49	53		55			
GST09...	71	75	77	82		83		89	
GST11...	119	123	125	129		131		137	
GST14...				222		224		230	

	17N C17 ...F10	17N C35 ...F10	19S C23 ...S00	19S C42 ...S00	19S C17 ...F10	19S C35 ...F10	21X C25 ...S00	21X C42 ...S00	21X C17 ...F10	21X C35 ...F10
GST09...	92									
GST11...	140		160		164		177		181	
GST14...	233		253		256		271		274	

Note additional weights.

Weights in [kg] with oil capacity for mounting position A, all given as approximate values



Additional weights MCS servo motors

	06C C41	06F C41	06I C41	09D C41	09F C38	09H C41	09L C41	12D C20	12D C41	12H C15	12H C30	12H C35	12L C20	12L C41
...P1	0.3			0.8			0.9							
...P2				0.5			1.2							
...SCS/SCM/SRM/SRS ...ECN/EQN	0.4			0.2			0.3							

	14D C15	14D C36	14H C15	14H C32	14L C15	14L C32	14P C14	14P C32	19F C14	19F C30	19J C14	19J C30	19P C14	19P C30
...P1	1.9						1.5							
...P2	3.1									4.3				
...SCS/SCM/SRM/SRS ...ECN/EQN							0.3							

Additional weights MCA servo motors

	10I C40 ...S00	13I C41 ...S00	13I C34 ...F10	14L C20 ...S00	14L C41 ...S00	14L C16 ...F10	14L C35 ...F10	17N C23 ...S00	17N C41 ...S00
...P1/P5								2.4	
...P2/P6	0.8	1.4		1.5					
...CDD ...ECN/EQN/EQI ...SCS/SCM/SRM/SRS/S20 ...T20	0.3	0.5		0.6			0.7		

	17N C17 ...F10	17N C35 ...F10	19S C23 ...S00	19S C42 ...S00	19S C17 ...F10	19S C35 ...F10	21X C25 ...S00	21X C42 ...S00	21X C17 ...F10	21X C35 ...F10
...P1/P5	2.4		4.8			5				
...P2/P6										
...CDD ...ECN/EQN/EQI ...SCS/SCM/SRM/SRS/S20 ...T20	0.7		1			1.1				

Additional weights gearbox

	Flange
	VAL/VCK
GST03...	0.8
GST04...	1
GST05...	1.5
GST06...	3
GST07...	4
GST09...	7
GST11...	10.5
GST14...	15.5

Weights in [kg]

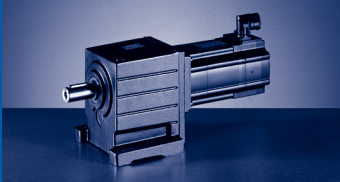

GST [i]

► $i_g = z_g / z_t$

	i	z_g	z_t
GST03-2	2.597	896	345
	3.413	1280	375
	4.368	1376	315
	5.312	1344	253
	5.965	1372	230
	6.982	1920	275
	7.84	1960	250
	8.935	2064	231
	10.033	2107	210
	11.429	2640	231
	12.833	2695	210
	14.836	2448	165
	16.66	2499	150
	19.013	2928	154
	21.35	2989	140
	24.595	2976	121
	27.618	3038	110
	32	3168	99
	35.933	3234	90
	41.455	4560	110
46.55	4655	100	
52.909	4656	88	
59.413	4753	80	
GST04-1	1.6	40	25
	2.048	43	21
	2.24	56	25
	2.857	60	21
	3.5	63	18
	4.4	66	15
	5.667	68	12
	7.182	79	11
	9	81	9
	11.857	83	7
GST04-2	2.956	1330	450
	3.333	1400	420
	4.053	1520	375
	4.571	1600	350
	5.187	1634	315
	5.85	1720	294
	6.4	2240	350
	7.04	1760	250
	8	1800	225
	9.01	1892	210
	9.856	2464	250
	11.2	2520	225

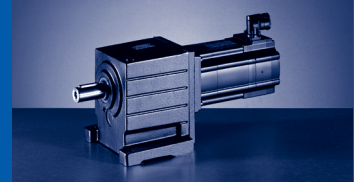

▶ $i_g = z_g / z_t$

	i	z_g	z_t
GST04-2	12.571	2640	210
	14.286	2700	189
	15.4	2772	180
	17.5	2835	162
	19.36	2904	150
	22	2970	135
	24.933	2992	120
	28.333	3060	108
	31.6	3476	110
	35.909	3555	99
	39.6	3564	90
	45	3645	81
	52.171	3652	70
	59.286	3735	63
GST05-1	1.6	40	25
	2.048	43	21
	2.24	56	25
	2.857	60	21
	3.5	63	18
	4.556	82	
	5.667	68	12
	7.333	88	
	8.9	89	10
	11.375	91	8
	GST05-2	2.956	1330
3.333		1400	420
4.053		1520	375
4.571		1600	350
5.187		1634	315
5.85		1720	294
6.4		2240	350
7.238		2280	315
8.163		2400	294
9.01		1892	210
10			252
11.2		2520	225
13.016		3280	252
14.356		2584	180
16.19		2720	168
17.5		2835	162
20.044		3608	180
22.778		3690	162
24.933		2992	120
28.333		3060	108
32.267	3872	120	

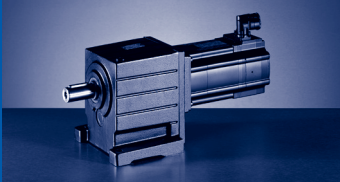

GST [i]

► $i_g = z_g / z_t$

	i	z_g	z_t
GST05-2	36.667	3960	108
	39.16	3916	100
	44.5	4005	90
	50.05	4004	80
	56.875	4095	72
GST05-3	36.267	152320	4200
	46.259	163200	3528
	56.667		3024
	63.467	171360	2700
	71.238	179520	2520
	80.952	183600	2268
	91.746	184960	2016
	99.167	192780	1944
	116.277	214880	1848
	124.667	201960	1620
	145.714	220320	1512
	160.556	208080	1296
	179.067	236368	1320
	191.973	225760	1176
	224.4	242352	1080
	255	247860	972
	295.638	248336	840
	335.952	253980	756
	GST06-1	1.6	40
2.048		43	21
2.24		56	25
2.857		60	21
3.5		63	
4.556		82	18
5.667		68	12
7.333		88	
8.9		89	10
11.25		90	8
GST06-2		3.033	1365
	3.333	1400	420
	4.16	1560	375
	4.571	1600	350
	5.324	1677	315
	5.85	1720	294
	6.4	2240	350
	7.04	1760	250
	8.163	2400	294
	9.01	1892	210
	10		252
	11.2	2520	225

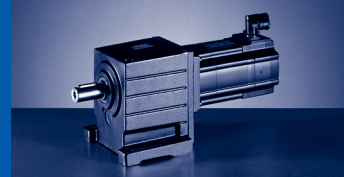

► $i_g = z_g / z_t$

	i	z_g	z_t
GST06-2	12.571	2640	210
	14.286	2700	189
	15.4	2772	180
	17.5	2835	162
	20.044	3608	180
	22.778	3690	162
	24.933	2992	120
	28.333	3060	108
	32.267	3872	120
	36.667	3960	108
	39.16	3916	100
	44.5	4005	90
	49.5	3960	80
	56.25	4050	72
GST06-3	39.2	158760	4050
	44	166320	3780
	51.022	206640	4050
	53.9	174636	3240
	67.76	182952	2700
	70.156	227304	3240
	80.952	183600	2268
	87.267	188496	2160
	99.167	192780	1944
	109.707	197472	1800
	124.667	201960	1620
	141.289	203456	1440
	160.556	208080	1296
	179.067	236368	1320
	203.485	241740	1188
	231.733	305888	1320
	255	247860	972
	290.4	313632	1080
	330	320760	972
	382.59	321376	840
434.762	328680	756	
GST07-1	1.625	39	24
	2	42	21
	2.24	56	25
	2.857	60	21
	3.5	63	18
	4.556	82	
	5.583	67	12
	7.333	88	
	8.9	89	10
	11.25	90	8

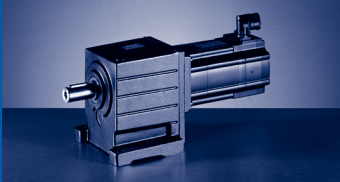

GST [i]

► $i_g = z_g / z_t$

	i	z_g	z_t
GST07-2	3.048	1326	435
	3.35	1360	406
	4.225	1521	360
	4.643	1560	336
	5.2	1638	315
	5.714	1680	294
	6.4	2240	350
	7.15	1716	240
	8.125	1755	216
	8.8	1848	210
	9.856	2464	250
	11.2	2520	225
	12.571	2640	210
	14.286	2700	189
	15.4	2772	180
	17.5	2835	162
	20.044	3608	180
	22.778	3690	162
	24.567	2948	120
	27.917	3015	108
	32.267	3872	120
	36.667	3960	108
	39.16	3916	100
	44.5	4005	90
	49.5	3960	80
56.25	4050	72	
GST07-3	39.2	158760	4050
	44	166320	3780
	51.022	206640	4050
	53.9	174636	3240
	65.079	221400	3402
	70.156	227304	3240
	79.762	180900	2268
	85.983	185724	2160
	97.708	189945	1944
	111.915	241736	2160
	127.176	247230	1944
	139.211	200464	1440
	158.194	205020	1296
	180.156	259424	1440
	204.722	265320	1296
	236.622	340736	1440
	248.458	268335	1080
	268.889	348480	1296
	326.333	352440	1080

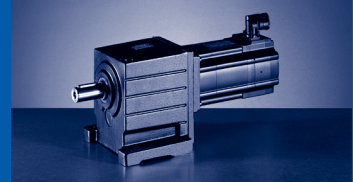

► $i_g = z_g / z_t$

	i	z_g	z_t
GST07-3	367.033	352352	960
	417.083	360360	864
GST09-1	1.56	39	25
	2.048	43	21
	2.333	56	24
	2.81	59	21
	3.444	62	18
	4.667	84	
	5.667	68	12
	7.333	88	
	8.9	89	
	11.25	90	8
GST09-2	4.056	1521	375
	4.457	1560	350
	5.324	1677	315
	5.85	1720	294
	6.667	2240	336
	7.305	2301	315
	8.027	2360	294
	9.01	1892	210
	10.267	2464	240
	11.667	2520	216
	12.362	2596	210
	14.048	2655	189
	15.156	2728	180
	17.222	2790	162
	20.533	3696	180
	23.333	3780	162
	24.933	2992	120
	28.333	3060	108
	32.267	3872	120
	36.667	3960	108
39.16	3916	100	
44.5	4005	90	
49.5	3960	80	
56.25	4050	72	
GST09-3	40.136	159300	3969
	43.267	163548	3780
	49.167	167265	3402
	53.044	171864	3240
	60.278	175770	2916
	71.867	232848	3240
	81.667	238140	2916
	93.541	303072	3240
99.167	192780	1944	

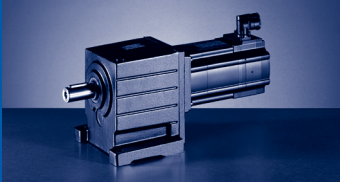

GST [i]

▶ $i_g = z_g / z_t$

	i	z_g	z_t
GST09-3	113.585	245344	2160
	129.074	250920	1944
	141.289	203456	1440
	160.556	208080	1296
	182.844	263296	1440
	207.778	269280	1296
	236.622	340736	1440
	252.167	272340	1080
	268.889	348480	1296
	326.333	352440	1080
	363	348480	960
	412.5	356400	864
GST11-2	4.056	1521	375
	4.457	1560	350
	5.324	1677	315
	5.85	1720	294
	6.4	2240	350
	6.864	1716	250
	7.8	1755	225
	9.01	1892	210
	9.856	2464	250
	11.2	2520	225
	12.571	2640	210
	14.286	2700	189
	15.4	2772	180
	17.5	2835	162
	20.289	3652	180
	23.056	3735	162
	24.933	2992	120
	28.333	3060	108
	32.267	3872	120
	36.667	3960	108
39.16	3916	100	
44.5	4005	90	
49.5	3960	80	
56.25	4050	72	
GST11-3	40.816	162000	3969
	44	166320	3780
	50	170100	3402
	57.968	219120	3780
	61.25	178605	2916
	71.011	230076	3240
	80.694	235305	2916
	87.267	188496	2160
99.167	192780	1944	



► $i_g = z_g / z_t$

	i	z_g	z_t
GST11-3	112.933	243936	2160
	129.074	250920	1944
	146.993	317504	2160
	158.194	205020	1296
	180.156	259424	1440
	207.778	269280	1296
	236.622	340736	1440
	252.167	272340	1080
	268.889	348480	1296
	326.333	352440	1080
	363	348480	960
	412.5	356400	864
GST14-2	4.225	1521	360
	4.643	1560	336
	5.2	1638	315
	5.714	1680	294
	6.286	2200	350
	7.15	1716	240
	8.027	2360	294
	8.8	1848	210
	9.841	2480	252
	11	2475	225
	12.362	2596	210
	14.048	2655	189
	15.156	2728	180
	17.222	2790	162
	20.044	3608	180
	22.778	3690	162
	24.567	2948	120
	27.917	3015	108
	32.267	3872	120
	36.667	3960	108
39.16	3916	100	
44.5	4005	90	
49.5	3960	80	
56.25	4050	72	
GST14-3	40.185	156240	3888
	42.58	160952	3780
	48.386	164610	3402
	53.148	206640	3888
	59.321	172980	2916
	69.042	223696	3240
	78.457	228780	2916
	93.541	303072	3240
96.157	186930	1944	

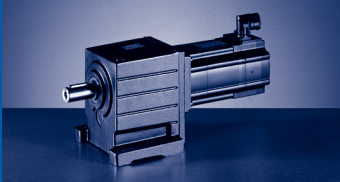

GST [i]

▶ $i_g = z_g / z_t$

	i	z_g	z_t
GST14-3	106.296	309960	2916
	130.278	253260	1944
	139.211	200464	1440
	158.194	205020	1296
	171.111	332640	1944
	204.722	265320	1296
	236.622	340736	1440
	248.458	268335	1080
	268.889	348480	1296
	326.333	352440	1080
	363	348480	960
	412.5	356400	864

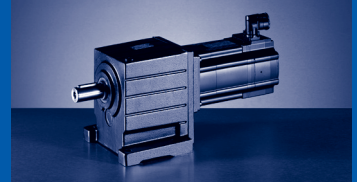

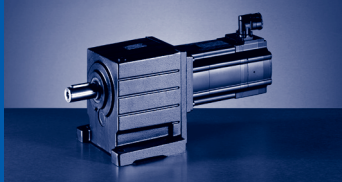

GST [Nm]

GST□□-□S (MCS)

$M_{2GN} \leq 45 \text{ Nm}$

GST03-2S				06CC41	06FC41	06IC41
				...500	...500	...500
i	M_{2GN}	J_G	M_1			
			n_1	4050	4050	4050
			I_{M230}	2.6	2.9	3.2
			I_{M400}	1.3	1.5	1.6
			P_N	0.25	0.51	0.64
			J_M	0.17	0.25	0.33
2.597	18	0.26	M_2		3	4
			c		4.3	3.4
			$n_{2 \text{ Eck}}$		1559	1559
			$n_{2 \text{ th}}$		1559	1559
3.413	19	0.17	M_2		4	5
			c		3.5	2.8
			$n_{2 \text{ Eck}}$		1187	1187
			$n_{2 \text{ th}}$		1187	1187
4.368	21	0.12	M_2	2	5	6
			c	5.9	3	2.4
			$n_{2 \text{ Eck}}$	927	927	927
			$n_{2 \text{ th}}$	927	927	927
5.312	27	0.18	M_2		6	8
			c		3.1	2.5
			$n_{2 \text{ Eck}}$		762	762
			$n_{2 \text{ th}}$		762	740
5.965	29	0.17	M_2	3	7	9
			c	5.9	3	2.4
			$n_{2 \text{ Eck}}$	679	679	679
			$n_{2 \text{ th}}$	679	679	653
6.982	30	0.12	M_2	4	8	10
			c	5.2	2.6	2.1
			$n_{2 \text{ Eck}}$	580	580	580
			$n_{2 \text{ th}}$	580	580	580
7.84	32	0.12	M_2	4	9	11
			c	5	2.5	2
			$n_{2 \text{ Eck}}$	517	517	517
			$n_{2 \text{ th}}$	517	517	517
8.935	33	0.09	M_2	5	10	13
			c	4.5	2.3	1.8
			$n_{2 \text{ Eck}}$	453	453	453
			$n_{2 \text{ th}}$	453	453	453
10.033	35	0.09	M_2	6	12	14
			c	4.3	2.1	1.7
			$n_{2 \text{ Eck}}$	404	404	404
			$n_{2 \text{ th}}$	404	404	404
11.429	35	0.06	M_2	7	13	17
			c	3.8	1.9	1.5
			$n_{2 \text{ Eck}}$	354	354	354
			$n_{2 \text{ th}}$	354	354	354
12.833	38	0.06	M_2	7	15	19
			c	3.6	1.8	1.5
			$n_{2 \text{ Eck}}$	316	316	316
			$n_{2 \text{ th}}$	316	316	316
14.836	39	0.04	M_2	8	17	22
			c	3.2	1.6	1.3
			$n_{2 \text{ Eck}}$	273	273	273
			$n_{2 \text{ th}}$	273	273	273
16.66	41	0.04	M_2	10	19	24
			c	3.5	1.7	1.4
			$n_{2 \text{ Eck}}$	243	243	243
			$n_{2 \text{ th}}$	243	243	243

$M \dots [\text{Nm}]$
 $n \dots [\text{min}^{-1}]$
 $J \dots [\text{kgcm}^2]$

$P \dots [\text{kW}]$
 $I \dots [\text{A}]$
 $i \dots [-]$
 $c \dots [-]$

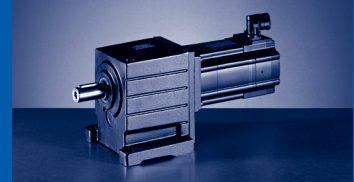

$M_{2GN} \leq 45 \text{ Nm}$

GST03-2S				06CC41	06FC41	06IC41
				...500	...500	...500
i	M_{2GN}	J_G	M_1			
			n_1	4050	4050	4050
			I_{M230}	2.6	2.9	3.2
			I_{M400}	1.3	1.5	1.6
			P_N	0.25	0.51	0.64
			J_M	0.17	0.25	0.33
19.013	42	0.03	M_2	11	22	28
			c	3.1	1.5	1.2
			$n_{2 \text{ Eck}}$	213	213	213
			$n_{2 \text{ th}}$	213	213	213
21.35	44	0.03	M_2	12	25	31
			c	2.9	1.5	1.2
			$n_{2 \text{ Eck}}$	190	190	190
			$n_{2 \text{ th}}$	190	190	190
24.595	45	0.02	M_2	14	29	36
			c	2.6	1.3	1
			$n_{2 \text{ Eck}}$	165	165	165
			$n_{2 \text{ th}}$	165	165	165
27.618	45	0.02	M_2	16	32	
			c	2.3	1.1	
			$n_{2 \text{ Eck}}$	147	147	
			$n_{2 \text{ th}}$	147	147	
32	45	0.01	M_2	18		
			c	2		
			$n_{2 \text{ Eck}}$	127		
			$n_{2 \text{ th}}$	127		
35.933	45	0.01	M_2	21		
			c	1.8		
			$n_{2 \text{ Eck}}$	113		
			$n_{2 \text{ th}}$	113		

M ... [Nm]
n ... [min^{-1}]
J ... [kgcm^2]

P ... [kW]
I ... [A]
i [-]
c [-]

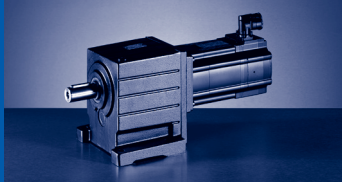

GST [Nm]

GST□□-□S (MCS)

$M_{2GN} \leq 25 \text{ Nm}$

GST04-1S				06CC41	06FC41	06IC41	09DC41	09FC38	09HC41	09LC41
				...500	...500	...500	...500	...500	...500	...500
i	M_{2GN}	J_G	M_1	0.6	1.2	1.5	2.3	3.1	3.8	4.5
			n_1	4050	4050	4050	4050	3750	4050	4050
			I_{M230}	2.6	2.9	3.2	4.6	5	6.8	8.4
			I_{M400}	1.3	1.5	1.6	2.3	2.5	3.4	4.2
			P_N	0.25	0.51	0.64	1	1.2	1.6	1.9
			J_M	0.17	0.25	0.33	1.13	1.53	1.93	2.83
1.6	19	0.27	M_2			2	4	5	6	7
			c			5.8	3.8	2.9	2.3	1.9
			$n_{2 \text{ Eck}}$			2531	2531	2344	2531	2531
			$n_{2 \text{ th}}$			2531	2380	2271	2179	2104
2.048	23	0.19	M_2			3	5	6	8	9
			c			5.4	3.5	2.7	2.1	1.8
			$n_{2 \text{ Eck}}$			1978	1978	1831	1978	1978
			$n_{2 \text{ th}}$			1978	1978	1831	1978	1867
2.24	25	0.17	M_2			3	5	7	8	10
			c			5.4	3.5	2.7	2.1	1.8
			$n_{2 \text{ Eck}}$			1808	1808	1674	1808	1808
			$n_{2 \text{ th}}$			1808	1808	1674	1808	1770
2.857	25	0.13	M_2		3	4	6	9	11	13
			c		5.3	4.3	2.8	2.1	1.7	1.4
			$n_{2 \text{ Eck}}$		1418	1418	1418	1313	1418	1418
			$n_{2 \text{ th}}$		1418	1418	1418	1313	1418	1418
3.5	25	0.1	M_2		4	5	8	11	13	15
			c		4.3	3.5	2.3	1.7	1.4	1.2
			$n_{2 \text{ Eck}}$		1157	1157	1157	1071	1157	1157
			$n_{2 \text{ th}}$		1157	1157	1157	1071	1157	1157
4.4	25	0.07	M_2		5	6				
			c		3.5	2.8				
			$n_{2 \text{ Eck}}$		921	921				
			$n_{2 \text{ th}}$		920	920				
5.667	25	0.05	M_2	3	7	8				
			c	5.4	2.7	2.1				
			$n_{2 \text{ Eck}}$	715	715	715				
			$n_{2 \text{ th}}$	715	715	715				

$M \dots$ [Nm]
 $n \dots$ [min^{-1}]
 $J \dots$ [kgcm^2]

$P \dots$ [kW]
 $I \dots$ [A]
 $i \dots$ [-]
 $c \dots$ [-]

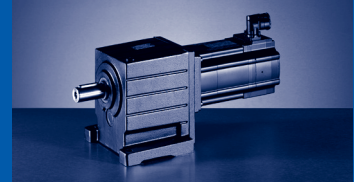

$M_{2GN} \leq 71 \text{ Nm}$

GST04-2S				06CC41	06FC41	06IC41	09DC41	09FC38	09HC41	09LC41
				...500	...500	...500	...500	...500	...500	...500
i	M_{2GN}	J_G	M_1	0.6	1.2	1.5	2.3	3.1	3.8	4.5
			n_1	4050	4050	4050	4050	3750	4050	4050
			I_{M230}	2.6	2.9	3.2	4.6	5	6.8	8.4
			I_{M400}	1.3	1.5	1.6	2.3	2.5	3.4	4.2
			P_N	0.25	0.51	0.64	1	1.2	1.6	1.9
			J_M	0.17	0.25	0.33	1.13	1.53	1.93	2.83
2.956	39	0.34	M_2				6	9	11	13
			c				4.3	3.2	2.6	2.2
			$n_{2 \text{ Eck}}$				1370	1269	1370	1370
			$n_{2 \text{ th}}$				1186	1127	1077	1041
3.333	42	0.32	M_2				7	10	12	14
			c				4	3.1	2.4	2.1
			$n_{2 \text{ Eck}}$				1215	1125	1215	1215
			$n_{2 \text{ th}}$				1041	989	945	912
4.053	45	0.31	M_2			6	9	12	15	18
			c			5.5	3.6	2.7	2.2	1.8
			$n_{2 \text{ Eck}}$			999	999	925	999	999
			$n_{2 \text{ th}}$			997	930	887	850	805
4.571	48	0.3	M_2			6	10	14	17	20
			c			5.2	3.4	2.6	2	1.7
			$n_{2 \text{ Eck}}$			886	886	820	886	886
			$n_{2 \text{ th}}$			876	816	778	746	694
5.187	50	0.22	M_2		6	7	11	15	19	23
			c		6	4.8	3.1	2.4	1.9	1.6
			$n_{2 \text{ Eck}}$		781	781	781	723	781	781
			$n_{2 \text{ th}}$		781	781	781	723	753	689
5.85	53	0.22	M_2		7	8	13	17	21	25
			c		5.6	4.5	2.9	2.2	1.8	1.5
			$n_{2 \text{ Eck}}$		692	692	692	641	692	692
			$n_{2 \text{ th}}$		692	692	692	641	648	594
6.4	55	0.19	M_2		7	9	14	19	23	28
			c		5.3	4.3	2.8	2.1	1.7	1.4
			$n_{2 \text{ Eck}}$		633	633	633	586	633	633
			$n_{2 \text{ th}}$		633	633	633	586	600	553
7.04	57	0.26	M_2		8	10	15	21	26	31
			c		5	4	2.6	2	1.6	1.3
			$n_{2 \text{ Eck}}$		575	575	575	533	575	575
			$n_{2 \text{ th}}$		565	545	506	482	431	400
8	59	0.26	M_2		9	11	18	24	29	35
			c		4.5	3.6	2.4	1.8	1.4	1.2
			$n_{2 \text{ Eck}}$		506	506	506	469	506	506
			$n_{2 \text{ th}}$		490	472	438	405	364	339
9.01	63	0.19	M_2		10	13	20	27	33	39
			c		4.3	3.4	2.2	1.7	1.4	1.1
			$n_{2 \text{ Eck}}$		450	450	450	416	450	450
			$n_{2 \text{ th}}$		450	450	450	412	368	341
9.856	65	0.17	M_2		11	14	22	29	36	43
			c		4.1	3.2	2.1	1.6	1.3	1.1
			$n_{2 \text{ Eck}}$		411	411	411	381	411	411
			$n_{2 \text{ th}}$		411	411	411	380	344	321
11.2	60	0.17	M_2		13	16	25	34	41	
			c		3.3	2.6	1.7	1.3	1	
			$n_{2 \text{ Eck}}$		362	362	362	335	362	
			$n_{2 \text{ th}}$		362	362	348	306	278	
12.571	69	0.13	M_2		14	18	28	38	46	
			c		3.4	2.7	1.8	1.4	1.1	
			$n_{2 \text{ Eck}}$		322	322	322	298	322	
			$n_{2 \text{ th}}$		322	322	322	298	291	

$M \dots$ [Nm]
 $n \dots$ [min^{-1}]
 $J \dots$ [kgcm^2]

$P \dots$ [kW]
 $I \dots$ [A]
 i [-]
 c [-]

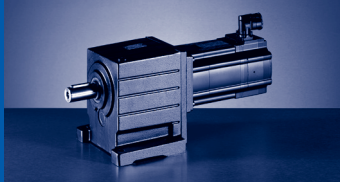

GST [Nm]

GST□□-□S (MCS)

$M_{2GN} \leq 71 \text{ Nm}$

GST04-2S				06CC41	06FC41	06IC41	09DC41	09FC38	09HC41	09LC41
				...S00	...S00	...S00	...S00	...S00	...S00	...S00
i	M_{2GN}	J_G	M_1							
			n_1	4050	4050	4050	4050	3750	4050	4050
			I_{M230}	2.6	2.9	3.2	4.6	5	6.8	8.4
			I_{M400}	1.3	1.5	1.6	2.3	2.5	3.4	4.2
			P_N	0.25	0.51	0.64	1	1.2	1.6	1.9
			J_M	0.17	0.25	0.33	1.13	1.53	1.93	2.83
14.286	61	0.12	M_2	8	16	21	32	43		
			c	5.3	2.6	2.1	1.4	1		
			$n_{2 \text{ Eck}}$	284	284	284	284	263		
			$n_{2 \text{ th}}$	284	284	284	280	254		
15.4	70	0.1	M_2		18	22	34	46	57	
			c		3.2	2.5	1.7	1.3	1	
			$n_{2 \text{ Eck}}$		263	263	263	244	263	
			$n_{2 \text{ th}}$		263	263	263	244	263	
17.5	62	0.1	M_2	10	20	25	39			
			c	4.9	2.5	2	1.3			
			$n_{2 \text{ Eck}}$	231	231	231	231			
			$n_{2 \text{ th}}$	231	231	231	231			
19.36	70	0.06	M_2	11	22	28				
			c	5.1	2.6	2				
			$n_{2 \text{ Eck}}$	209	209	209				
			$n_{2 \text{ th}}$	209	209	209				
22	62	0.06	M_2	12	25	32				
			c	4	2	1.6				
			$n_{2 \text{ Eck}}$	184	184	184				
			$n_{2 \text{ th}}$	184	184	184				
24.933	71	0.04	M_2	14	29	36				
			c	4	2	1.6				
			$n_{2 \text{ Eck}}$	162	162	162				
			$n_{2 \text{ th}}$	162	162	162				
28.333	63	0.04	M_2	16	33	41				
			c	3.1	1.6	1.3				
			$n_{2 \text{ Eck}}$	143	143	143				
			$n_{2 \text{ th}}$	143	143	143				

$M \dots$ [Nm]
 $n \dots$ [min^{-1}]
 $J \dots$ [kgcm^2]

$P \dots$ [kW]
 $I \dots$ [A]
 i [-]
 c [-]

GST [Nm]
GST□□-□S (MCS)

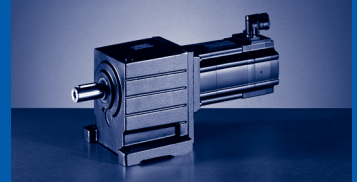

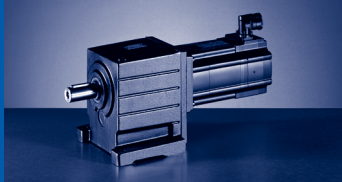

GST [Nm]

GST□□-□S (MCS)

$M_{2GN} \leq 54 \text{ Nm}$

GST05-1S				06CC41	06FC41	06IC41	09DC41	09FC38	09HC41	09LC41
				...500	...500	...500	...500	...500	...500	...500
i	M_{2GN}	J_G	M_1	0.6	1.2	1.5	2.3	3.1	3.8	4.5
			n_1	4050	4050	4050	4050	3750	4050	4050
			I_{M230}	2.6	2.9	3.2	4.6	5	6.8	8.4
			I_{M400}	1.3	1.5	1.6	2.3	2.5	3.4	4.2
			P_N	0.25	0.51	0.64	1	1.2	1.6	1.9
			J_M	0.17	0.25	0.33	1.13	1.53	1.93	2.83
1.6	45	0.76	M_2						6	7
			c					5.4	4.5	
			$n_{2 \text{ Eck}}$					2531	2531	
			$n_{2 \text{ th}}$					2236	2168	
2.048	51	0.55	M_2					6	7	9
			c					6	4.8	4
			$n_{2 \text{ Eck}}$					1831	1978	1978
			$n_{2 \text{ th}}$					1831	1862	1809
2.048	53	0.55	M_2							
			c							
			$n_{2 \text{ Eck}}$							
			$n_{2 \text{ th}}$							
2.24	53	0.48	M_2					7	8	10
			c					5.7	4.5	3.8
			$n_{2 \text{ Eck}}$					1674	1808	1808
			$n_{2 \text{ th}}$					1674	1748	1699
2.857	53	0.35	M_2				6	8	10	12
			c				5.9	4.5	3.6	3
			$n_{2 \text{ Eck}}$				1418	1313	1418	1418
			$n_{2 \text{ th}}$				1418	1313	1418	1418
3.5	41	0.27	M_2			5				
			c			5.7				
			$n_{2 \text{ Eck}}$			1157				
			$n_{2 \text{ th}}$			1157				
3.5	54	0.27	M_2				8	10	13	15
			c				4.9	3.7	3	2.5
			$n_{2 \text{ Eck}}$				1157	1071	1157	1157
			$n_{2 \text{ th}}$				1157	1071	1157	1157
4.556	42	0.18	M_2		5	7				
			c		5.7	4.5				
			$n_{2 \text{ Eck}}$		889	889				
			$n_{2 \text{ th}}$		889	889				
4.556	54	0.18	M_2				10	14	17	20
			c				3.8	2.9	2.3	1.9
			$n_{2 \text{ Eck}}$				889	823	889	889
			$n_{2 \text{ th}}$				889	823	889	889
5.667	44	0.13	M_2		6	8				
			c		4.7	3.8				
			$n_{2 \text{ Eck}}$		715	715				
			$n_{2 \text{ th}}$		715	715				
5.667	54	0.13	M_2				13	17	21	25
			c				3	2.3	1.8	1.5
			$n_{2 \text{ Eck}}$				715	662	715	715
			$n_{2 \text{ th}}$				715	662	715	715
7.333	46	0.06	M_2		8	11				
			c		3.8	3				
			$n_{2 \text{ Eck}}$		552	552				
			$n_{2 \text{ th}}$		552	552				
8.9	42	0.06	M_2	5	10	13				
			c	5.8	2.9	2.3				
			$n_{2 \text{ Eck}}$	455	455	455				
			$n_{2 \text{ th}}$	455	455	455				

$M \dots [\text{Nm}]$
 $n \dots [\text{min}^{-1}]$
 $J \dots [\text{kgcm}^2]$

$P \dots [\text{kW}]$
 $I \dots [\text{A}]$
 $i \dots [-]$
 $c \dots [-]$

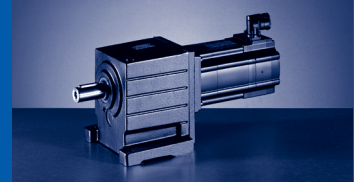

$M_{2GN} \leq 54 \text{ Nm}$

12DC20	12DC41	12HC15	12HC30	12HC35	12LC20	12LC41	GST05-1S			
...500	...500	...500	...500	...500	...500	...500				
5.5	4.3	10	8	7.5	13.5	11	M_1	J_G	M_{2GN}	i
1950	4050	1500	3000	3525	1950	4050	n_1			
5.2	8.8	7.6	10.5		11.8		I_{M230}			
2.6	4.5	3.8		5.7	5.9	10.2	I_{M400}			
1.1	1.8	1.6	2.5	2.8	2.8	4.7	P_N			
4.12	4.12	7.42	7.42	7.42	10.72	10.72	J_M			
8	7	15	12	12	21	17	M_2			
4.7	4.7	2.8	2.8	2.8	1.9	1.9	c	0.76	45	1.6
1219	2531	938	1875	2203	1219	2531	$n_{2 \text{ Eck}}$			
1219	2186	938	1875	1982	1219	1771	$n_{2 \text{ th}}$			
							M_2			
							c	0.55	51	2.048
							$n_{2 \text{ Eck}}$			
							$n_{2 \text{ th}}$			
11	8	20	16	15	27	22	M_2			
4.3	4.4	2.6	2.6	2.6	1.8	1.7	c	0.55	53	2.048
952	1978	733	1465	1722	952	1978	$n_{2 \text{ Eck}}$			
952	1834	733	1465	1674	952	1470	$n_{2 \text{ th}}$			
12	9	22	17	16	30	24	M_2			
4	4	2.4	2.4	2.4	1.6	1.6	c	0.48	53	2.24
871	1808	670	1339	1574	871	1808	$n_{2 \text{ Eck}}$			
871	1712	670	1339	1567	871	1351	$n_{2 \text{ th}}$			
15	12	28	22	21	38	31	M_2			
3.1	3.2	1.9	1.9	1.9	1.3	1.2	c	0.35	53	2.857
683	1418	525	1050	1234	683	1418	$n_{2 \text{ Eck}}$			
683	1418	525	1050	1234	683	1120	$n_{2 \text{ th}}$			
							M_2			
							c	0.27	41	3.5
							$n_{2 \text{ Eck}}$			
							$n_{2 \text{ th}}$			
19	15	34	27	26	47	38	M_2			
2.6	2.6	1.6	1.6	1.6	1.1	1	c	0.27	54	3.5
557	1157	429	857	1007	557	1157	$n_{2 \text{ Eck}}$			
557	1157	429	857	1007	557	969	$n_{2 \text{ th}}$			
							M_2			
							c	0.18	42	4.556
							$n_{2 \text{ Eck}}$			
							$n_{2 \text{ th}}$			
							M_2			
							c	0.18	54	4.556
							$n_{2 \text{ Eck}}$			
							$n_{2 \text{ th}}$			
							M_2			
							c	0.13	44	5.667
							$n_{2 \text{ Eck}}$			
							$n_{2 \text{ th}}$			
							M_2			
							c	0.13	54	5.667
							$n_{2 \text{ Eck}}$			
							$n_{2 \text{ th}}$			
							M_2			
							c	0.06	46	7.333
							$n_{2 \text{ Eck}}$			
							$n_{2 \text{ th}}$			
							M_2			
							c	0.06	42	8.9
							$n_{2 \text{ Eck}}$			
							$n_{2 \text{ th}}$			

M ... [Nm]
n ... [min⁻¹]
J ... [kgcm²]

P ... [kW]
I ... [A]
i [-]
c [-]

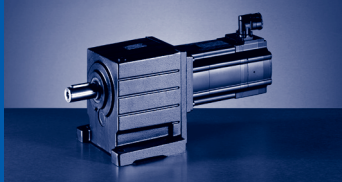

GST [Nm]

GST□□-□S (MCS)

$M_{2GN} \leq 165 \text{ Nm}$

GST05-2S				06CC41	06FC41	06IC41	09DC41	09FC38	09HC41	09LC41
				...500	...500	...500	...500	...500	...500	...500
i	M_{2GN}	J_G	M_1	0.6	1.2	1.5	2.3	3.1	3.8	4.5
			n_1	4050	4050	4050	4050	3750	4050	4050
			I_{M230}	2.6	2.9	3.2	4.6	5	6.8	8.4
			I_{M400}	1.3	1.5	1.6	2.3	2.5	3.4	4.2
			P_N	0.25	0.51	0.64	1	1.2	1.6	1.9
			J_M	0.17	0.25	0.33	1.13	1.53	1.93	2.83
2.956	63	0.99	M_2					9	11	13
			c				5.2	4.2	3.5	
			n_2 Eck				1269	1370	1370	
			n_2 th					1029	985	953
3.333	78	0.94	M_2					10	12	14
			c				5.7	4.6	3.9	
			n_2 Eck				1125	1215	1215	
			n_2 th					928	889	860
4.053	81	0.9	M_2					12	14	17
			c				4.9	3.9	3.3	
			n_2 Eck				925	999	999	
			n_2 th					869	832	806
4.571	91	0.86	M_2					13	16	19
			c				4.9	3.9	3.3	
			n_2 Eck				820	886	886	
			n_2 th					770	738	714
5.187	90	0.64	M_2			11	15	15	19	22
			c			5.6	4.3	3.4	2.9	
			n_2 Eck			781	723	781	781	
			n_2 th			755	721	693	672	
5.85	101	0.61	M_2			12	17	17	21	25
			c			5.6	4.2	3.4	2.9	
			n_2 Eck			692	641	692	692	
			n_2 th			669	639	614	596	
6.4	105	0.53	M_2			14	19	19	23	27
			c			5.3	4	3.2	2.7	
			n_2 Eck			633	586	633	633	
			n_2 th			627	586	576	559	
7.238	108	0.4	M_2			16	21	21	26	31
			c			4.8	3.7	2.9	2.5	
			n_2 Eck			560	518	560	560	
			n_2 th			560	518	560	560	
8.163	115	0.39	M_2			18	24	24	30	35
			c			4.5	3.5	2.8	2.3	
			n_2 Eck			496	459	496	496	
			n_2 th			496	459	496	496	
9.01	119	0.54	M_2			19	26	26	33	39
			c			4.2	3.2	2.6	2.2	
			n_2 Eck			450	416	450	450	
			n_2 th			415	396	379	367	
10	114	0.3	M_2		14					
			c		5.7					
			n_2 Eck		405					
			n_2 th		405					
10	124	0.3	M_2				22	29	36	43
			c				4	3	2.4	2
			n_2 Eck				405	375	405	405
			n_2 th				405	375	405	405
11.2	128	0.46	M_2		16	24	33	33	41	48
			c		5.6	3.7	2.8	2.2	1.9	
			n_2 Eck		362	362	335	362	362	
			n_2 th		362	337	322	309	294	

$M \dots$ [Nm]
 $n \dots$ [min^{-1}]
 $J \dots$ [kgcm^2]

$P \dots$ [kW]
 $I \dots$ [A]
 $i \dots$ [-]
 $c \dots$ [-]

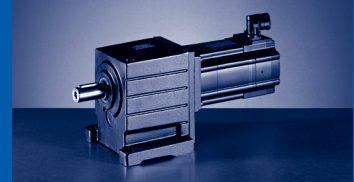

$M_{2GN} \leq 165 \text{ Nm}$

12DC20	12DC41	12HC15	12HC30	12HC35	12LC20	12LC41	GST05-2S			
...500	...500	...500	...500	...500	...500	...500				
5.5	4.3	10	8	7.5	13.5	11	M_1	J_G	M_{2GN}	i
1950	4050	1500	3000	3525	1950	4050	n_1			
5.2	8.8	7.6	10.5		11.8		I_{M230}			
2.6	4.5	3.8		5.7	5.9	10.2	I_{M400}			
1.1	1.8	1.6	2.5	2.8	2.8	4.7	P_N			
4.12	4.12	7.42	7.42	7.42	10.72	10.72	J_M			
15	12	28	23	21	39	31	M_2			
3.7	3.7	2.2	2.2	2.2	1.5	1.4	c	0.99	63	2.956
660	1370	508	1015	1193	660	1370	$n_{2\text{Eck}}$			
660	961	508	861	863	660	708	$n_{2\text{th}}$			
17	13	32	26	24	43	35	M_2			
4	4	2.4	2.4	2.4	1.6	1.6	c	0.94	78	3.333
585	1215	450	900	1058	585	1215	$n_{2\text{Eck}}$			
585	868	450	779	781	585	659	$n_{2\text{th}}$			
21	16	39	31	29	53	43	M_2			
3.4	3.5	2.1	2.1	2.1	1.4	1.4	c	0.9	81	4.053
481	999	370	740	870	481	999	$n_{2\text{Eck}}$			
481	813	370	731	732	481	589	$n_{2\text{th}}$			
24	19	44	35	33	60	49	M_2			
3.4	3.4	2.1	2	2.1	1.4	1.3	c	0.86	91	4.571
427	886	328	656	771	427	886	$n_{2\text{Eck}}$			
427	720	328	647	649	427	521	$n_{2\text{th}}$			
27	21	50	40	37	68	55	M_2			
3	3	1.8	1.8	1.8	1.2	1.2	c	0.64	90	5.187
376	781	289	578	680	376	781	$n_{2\text{Eck}}$			
376	677	289	578	596	376	489	$n_{2\text{th}}$			
31	24	56	45	42	76	62	M_2			
3	3	1.8	1.8	1.8	1.2	1.2	c	0.61	101	5.85
333	692	256	513	603	333	692	$n_{2\text{Eck}}$			
333	601	256	513	528	333	433	$n_{2\text{th}}$			
34	26	62	49	46	84	68	M_2			
2.8	2.8	1.7	1.7	1.7	1.2	1.1	c	0.53	105	6.4
305	633	234	469	551	305	633	$n_{2\text{Eck}}$			
305	564	234	469	490	305	408	$n_{2\text{th}}$			
38	30	70	56	52	95	77	M_2			
2.6	2.6	1.5	1.5	1.6	1.1	1	c	0.4	108	7.238
269	560	207	415	487	269	560	$n_{2\text{Eck}}$			
269	560	207	414	487	269	407	$n_{2\text{th}}$			
43	34	79	63	59			M_2			
2.4	2.4	1.5	1.4	1.5			c	0.39	115	8.163
239	496	184	368	432			$n_{2\text{Eck}}$			
239	496	184	368	424			$n_{2\text{th}}$			
47	37	87	70	65			M_2			
2.3	2.3	1.4	1.4	1.4			c	0.54	119	9.01
216	450	167	333	391			$n_{2\text{Eck}}$			
216	371	166	300	301			$n_{2\text{th}}$			
							M_2			
							c	0.3	114	10
							$n_{2\text{Eck}}$			
							$n_{2\text{th}}$			
53	41	97	77	73			M_2			
2.1	2.1	1.3	1.3	1.3			c	0.3	124	10
195	405	150	300	353			$n_{2\text{Eck}}$			
195	405	150	300	353			$n_{2\text{th}}$			
59	46	108	87	81			M_2			
2	2	1.2	1.2	1.2			c	0.46	128	11.2
174	362	134	268	315			$n_{2\text{Eck}}$			
174	301	134	238	239			$n_{2\text{th}}$			

$M \dots$ [Nm]
 $n \dots$ [min^{-1}]
 $J \dots$ [kgcm^2]

$P \dots$ [kW]
 $I \dots$ [A]
 i [-]
 c [-]

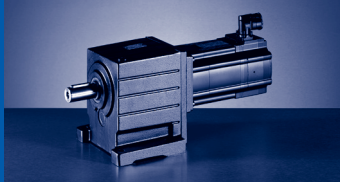

GST [Nm]

GST□□-□S (MCS)

$M_{2GN} \leq 165 \text{ Nm}$

GST05-2S				06CC41	06FC41	06IC41	09DC41	09FC38	09HC41	09LC41
				...500	...500	...500	...500	...500	...500	...500
i	M_{2GN}	J_G	M_1	0.6	1.2	1.5	2.3	3.1	3.8	4.5
			n_1	4050	4050	4050	4050	3750	4050	4050
			I_{M230}	2.6	2.9	3.2	4.6	5	6.8	8.4
			I_{M400}	1.3	1.5	1.6	2.3	2.5	3.4	4.2
			P_N	0.25	0.51	0.64	1	1.2	1.6	1.9
			J_M	0.17	0.25	0.33	1.13	1.53	1.93	2.83
13.016	119	0.18	M_2		14	18				
			c		5.7	4.5				
			$n_{2 \text{ Eck}}$		311	311				
			$n_{2 \text{ th}}$		311	311				
13.016	137	0.18	M_2				28	39	47	56
			c				3.4	2.6	2.1	1.7
			$n_{2 \text{ Eck}}$				311	288	311	311
			$n_{2 \text{ th}}$				311	288	311	311
14.356	110	0.13	M_2		16	20				
			c		4.7	3.8				
			$n_{2 \text{ Eck}}$		282	282				
			$n_{2 \text{ th}}$		282	282				
14.356	140	0.13	M_2				31	43	52	62
			c				3.1	2.4	1.9	1.6
			$n_{2 \text{ Eck}}$				282	261	282	282
			$n_{2 \text{ th}}$				282	261	282	282
16.19	124	0.13	M_2		18	23				
			c		5.4	4.3				
			$n_{2 \text{ Eck}}$		250	250				
			$n_{2 \text{ th}}$		250	250				
16.19	148	0.13	M_2				35	48	59	70
			c				3.4	2.6	2	1.7
			$n_{2 \text{ Eck}}$				250	232	250	250
			$n_{2 \text{ th}}$				250	232	250	250
17.5	142	0.27	M_2		19	25	38	52	64	76
			c		5.7	4.6	3	2.3	1.8	1.5
			$n_{2 \text{ Eck}}$		231	231	231	214	231	231
			$n_{2 \text{ th}}$		231	231	231	214	231	226
20.044	159	0.16	M_2		22	28	44	60	73	87
			c		5.6	4.5	2.9	2.2	1.8	1.5
			$n_{2 \text{ Eck}}$		202	202	202	187	202	202
			$n_{2 \text{ th}}$		202	202	202	187	202	202
22.778	144	0.16	M_2		26	32	50	68	84	99
			c		4.4	3.5	2.3	1.8	1.4	1.2
			$n_{2 \text{ Eck}}$		178	178	178	165	178	178
			$n_{2 \text{ th}}$		178	178	178	165	178	178
24.933	162	0.12	M_2		28	35	55	74	92	109
			c		4.6	3.6	2.4	1.8	1.4	1.2
			$n_{2 \text{ Eck}}$		162	162	162	150	162	162
			$n_{2 \text{ th}}$		162	162	162	150	162	162
28.333	147	0.12	M_2		32	40	63	85	104	
			c		3.6	2.9	1.9	1.4	1.2	
			$n_{2 \text{ Eck}}$		143	143	143	132	143	
			$n_{2 \text{ th}}$		143	143	143	132	143	
32.267	164	0.08	M_2		37	46				
			c		3.6	2.9				
			$n_{2 \text{ Eck}}$		126	126				
			$n_{2 \text{ th}}$		126	126				
36.667	148	0.08	M_2	20	42	53				
			c	5.7	2.8	2.3				
			$n_{2 \text{ Eck}}$	111	111	111				
			$n_{2 \text{ th}}$	110	110	110				

$M \dots [\text{Nm}]$
 $n \dots [\text{min}^{-1}]$
 $J \dots [\text{kgcm}^2]$

$P \dots [\text{kW}]$
 $I \dots [\text{A}]$
 $i \dots [-]$
 $c \dots [-]$

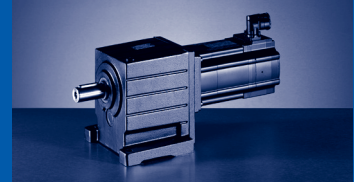

$M_{2GN} \leq 165 \text{ Nm}$

12DC20	12DC41	12HC15	12HC30	12HC35	12LC20	12LC41	GST05-2S			
...500	...500	...500	...500	...500	...500	...500				
5.5	4.3	10	8	7.5	13.5	11	M_1	J_G	M_{2GN}	i
1950	4050	1500	3000	3525	1950	4050	n_1			
5.2	8.8	7.6	10.5		11.8		I_{M230}			
2.6	4.5	3.8		5.7	5.9	10.2	I_{M400}			
1.1	1.8	1.6	2.5	2.8	2.8	4.7	P_N			
4.12	4.12	7.42	7.42	7.42	10.72	10.72	J_M			
							M_2 c	0.18	119	13.016
							n_2 Eck			
							n_2 th			
							M_2 c	0.18	137	13.016
							n_2 Eck			
							n_2 th			
							M_2 c	0.13	110	14.356
							n_2 Eck			
							n_2 th			
							M_2 c	0.13	140	14.356
							n_2 Eck			
							n_2 th			
							M_2 c	0.13	124	16.19
							n_2 Eck			
							n_2 th			
							M_2 c	0.13	148	16.19
							n_2 Eck			
							n_2 th			
93	73						M_2 c	0.27	142	17.5
1.5	1.6						n_2 Eck			
111	231						n_2 th			
111	231						M_2 c	0.16	159	20.044
							n_2 Eck			
							n_2 th			
							M_2 c	0.16	144	22.778
							n_2 Eck			
							n_2 th			
							M_2 c	0.12	162	24.933
							n_2 Eck			
							n_2 th			
							M_2 c	0.12	147	28.333
							n_2 Eck			
							n_2 th			
							M_2 c	0.08	164	32.267
							n_2 Eck			
							n_2 th			
							M_2 c	0.08	148	36.667
							n_2 Eck			
							n_2 th			

M ... [Nm]
n ... [min⁻¹]
J ... [kgcm²]

P ... [kW]
I ... [A]
i [-]
c [-]

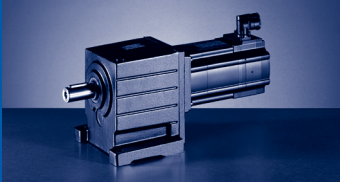

GST [Nm]

GST□□-□S (MCS)

$M_{2GN} \leq 165 \text{ Nm}$

GST05-2S				06CC41	06FC41	06IC41	09DC41	09FC38	09HC41	09LC41
				...S00	...S00	...S00	...S00	...S00	...S00	...S00
i	M_{2GN}	J_G	M_1	0.6	1.2	1.5	2.3	3.1	3.8	4.5
			n_1	4050	4050	4050	4050	3750	4050	4050
			I_{M230}	2.6	2.9	3.2	4.6	5	6.8	8.4
			I_{M400}	1.3	1.5	1.6	2.3	2.5	3.4	4.2
			P_N	0.25	0.51	0.64	1	1.2	1.6	1.9
			J_M	0.17	0.25	0.33	1.13	1.53	1.93	2.83
39.16	165	0.06	M_2	22	45	56				
			c	5.9	3	2.4				
			$n_{2 \text{ Eck}}$	103	103	103				
			$n_{2 \text{ th}}$	103	103	103				
44.5	149	0.06	M_2	25	51	64				
			c	5.2	2.6	2.1				
			$n_{2 \text{ Eck}}$	91	91	91				
			$n_{2 \text{ th}}$	91	91	91				

M ... [Nm]
 n ... [min⁻¹]
 J ... [kgcm²]

P ... [kW]
 I ... [A]
 i [-]
 c [-]



$M_{2GN} \leq 165 \text{ Nm}$

12DC20	12DC41	12HC15	12HC30	12HC35	12LC20	12LC41	GST05-2S			
...S00	...S00	...S00	...S00	...S00	...S00	...S00	M_1	J_G	M_{2GN}	i
5.5	4.3	10	8	7.5	13.5	11	n_1			
1950	4050	1500	3000	3525	1950	4050	I_{M230}			
5.2	8.8	7.6	10.5		11.8		I_{M400}			
2.6	4.5	3.8		5.7	5.9	10.2	P_N			
1.1	1.8	1.6	2.5	2.8	2.8	4.7	J_M			
4.12	4.12	7.42	7.42	7.42	10.72	10.72	M_2			
							c	0.06	165	39.16
							$n_{2 \text{ Eck}}$			
							$n_{2 \text{ th}}$			
							M_2			
							c	0.06	149	44.5
							$n_{2 \text{ Eck}}$			
							$n_{2 \text{ th}}$			

M ... [Nm]
n ... [min⁻¹]
J ... [kgcm²]

P ... [kW]
I ... [A]
i [-]
c [-]

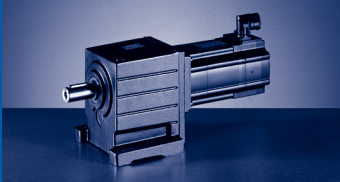

GST [Nm]

GST□□-□S (MCS)

$M_{2GN} \leq 171 \text{ Nm}$

GST05-3S				06CC41	06FC41	06IC41	09DC41	09FC38
				...500	...500	...500	...500	...500
i	M_{2GN}	J_G	M_1					
			n_1	4050	4050	4050	4050	3750
			I_{M230}	2.6	2.9	3.2	4.6	5
			I_{M400}	1.3	1.5	1.6	2.3	2.5
			P_N	0.25	0.51	0.64	1	1.2
			J_M	0.17	0.25	0.33	1.13	1.53
36.267	134	0.2	M_2	20	41	51	79	107
			c	5.3	2.6	2.1	1.4	1.1
			$n_{2 \text{ Eck}}$	112	112	112	112	103
			$n_{2 \text{ th}}$	112	112	112	112	103
46.259	145	0.14	M_2	25	52	66	101	
			c	5	2.5	2	1.3	
			$n_{2 \text{ Eck}}$	88	88	88	88	
			$n_{2 \text{ th}}$	88	88	88	88	
56.667	155	0.11	M_2	31	64	81	124	
			c	4.3	2.2	1.7	1.1	
			$n_{2 \text{ Eck}}$	72	72	72	72	
			$n_{2 \text{ th}}$	71	71	71	71	
63.467	146	0.19	M_2	35	72	91		
			c	3.6	1.8	1.5		
			$n_{2 \text{ Eck}}$	64	64	64		
			$n_{2 \text{ th}}$	64	64	64		
71.238	167	0.07	M_2	40	81	102		
			c	3.7	1.9	1.5		
			$n_{2 \text{ Eck}}$	57	57	57		
			$n_{2 \text{ th}}$	57	57	57		
80.952	147	0.14	M_2	46	92	116		
			c	2.9	1.4	1.2		
			$n_{2 \text{ Eck}}$	50	50	50		
			$n_{2 \text{ th}}$	50	50	50		
91.746	171	0.05	M_2	52	105	131		
			c	2.9	1.5	1.2		
			$n_{2 \text{ Eck}}$	44	44	44		
			$n_{2 \text{ th}}$	44	44	44		
99.167	148	0.11	M_2	56	114			
			c	2.4	1.2			
			$n_{2 \text{ Eck}}$	41	41			
			$n_{2 \text{ th}}$	41	41			
124.667	149	0.07	M_2	71				
			c	1.9				
			$n_{2 \text{ Eck}}$	33				
			$n_{2 \text{ th}}$	32				
160.556	150	0.05	M_2	92				
			c	1.5				
			$n_{2 \text{ Eck}}$	25				
			$n_{2 \text{ th}}$	25				

$M \dots [\text{Nm}]$
 $n \dots [\text{min}^{-1}]$
 $J \dots [\text{kgcm}^2]$

$P \dots [\text{kW}]$
 $I \dots [\text{A}]$
 $i [-]$
 $c [-]$

GST [Nm]
GST□□-□S (MCS)

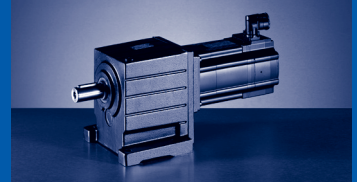

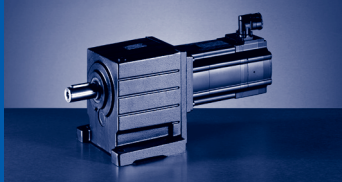

GST [Nm]

GST□□-□S (MCS)

$M_{2GN} \leq 105 \text{ Nm}$

GST06-1S				06FC41	06IC41	09DC41	09FC38	09HC41	09LC41	12DC20	12DC41	12HC15	12HC30	
				...500	...500	...500	...500	...500	...500	...500	...500	...500	...500	
i	M_{2GN}	J_G	M_1	1.2	1.5	2.3	3.1	3.8	4.5	5.5	4.3	10	8	
			n_1	4050	4050	4050	3750	4050	4050	1950	4050	1500	3000	
			I_{M230}	2.9	3.2	4.6	5	6.8	8.4	5.2	8.8	7.6	10.5	
			I_{M400}	1.5	1.6	2.3	2.5	3.4	4.2	2.6	4.5	3.8		
			P_N	0.51	0.64	1	1.2	1.6	1.9	1.1	1.8	1.6	2.5	
			J_M	0.25	0.33	1.13	1.53	1.93	2.83	4.12	4.12	7.42	7.42	
1.6	61	2.01	M_2									15	12	
			c										3.9	3.9
			$n_{2 \text{ Eck}}$										938	1875
			$n_{2 \text{ th}}$										938	1759
2.048	63	1.46	M_2					7	9					
			c					5.9	5					
			$n_{2 \text{ Eck}}$					1978	1978					
			$n_{2 \text{ th}}$					1725	1672					
2.048	72	1.46	M_2							11	8	20	16	
			c							6	6	3.6	3.6	
			$n_{2 \text{ Eck}}$							952	1978	733	1465	
			$n_{2 \text{ th}}$							952	1730	733	1465	
2.24	66	1.27	M_2					8	10					
			c					5.6	4.8					
			$n_{2 \text{ Eck}}$					1808	1808					
			$n_{2 \text{ th}}$					1612	1564					
2.24	79	1.27	M_2							12	9	21	17	
			c							5.9	5.9	3.6	3.5	
			$n_{2 \text{ Eck}}$							871	1808	670	1339	
			$n_{2 \text{ th}}$							871	1627	670	1339	
2.857	71	0.97	M_2				8	10	12					
			c				6	4.8	4					
			$n_{2 \text{ Eck}}$				1313	1418	1418					
			$n_{2 \text{ th}}$				1313	1346	1309					
2.857	91	0.97	M_2							15	12	28	22	
			c							5.4	5.4	3.3	3.2	
			$n_{2 \text{ Eck}}$							683	1418	525	1050	
			$n_{2 \text{ th}}$							683	1376	525	1050	
2.857	92	0.97	M_2											
			c											
			$n_{2 \text{ Eck}}$											
			$n_{2 \text{ th}}$											
3.5	74	0.74	M_2				10	13	15					
			c				5.1	4.1	3.4					
			$n_{2 \text{ Eck}}$				1071	1157	1157					
			$n_{2 \text{ th}}$				1071	1157	1157					
3.5	96	0.74	M_2							18	14	34	27	
			c							4.6	4.7	2.8	2.8	
			$n_{2 \text{ Eck}}$							557	1157	429	857	
			$n_{2 \text{ th}}$							557	1157	429	857	
3.5	105	0.74	M_2											
			c											
			$n_{2 \text{ Eck}}$											
			$n_{2 \text{ th}}$											
4.556	52	0.48	M_2		6									
			c		5.6									
			$n_{2 \text{ Eck}}$		889									
			$n_{2 \text{ th}}$		889									
4.556	78	0.48	M_2			10	13	17	20					
			c			5.4	4.1	3.3	2.8					
			$n_{2 \text{ Eck}}$			889	823	889	889					
			$n_{2 \text{ th}}$			889	823	889	889					

$M \dots [\text{Nm}]$
 $n \dots [\text{min}^{-1}]$
 $J \dots [\text{kgcm}^2]$

$P \dots [\text{kW}]$
 $I \dots [\text{A}]$
 $i \dots [-]$
 $c \dots [-]$

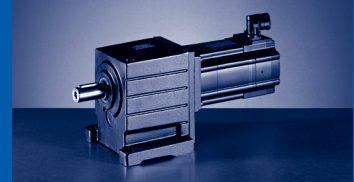

$M_{2GN} \leq 105 \text{ Nm}$

12HC35	12LC20	12LC41	14DC15	14DC36	14HC15	14HC32	14LC15	14LC32	14PC14	14PC32	GST06-1S			
...S00	...S00	...S00	...S00	...S00	...S00	...S00	...S00	...S00	...S00	...S00	M_1	J_G	M_{2GN}	i
7.5	13.5	11	9.2	7.5	16	14	23	17.2	30	21	n_1			
3525	1950	4050	1500	3600	1500	3225	1500	3225	1350	3225	I_{M230}			
	11.8										I_{M400}			
5.7	5.9	10.2	4.5	7.5	6.6	11.9	9.7	15	10.8	15.6	P_N			
2.8	2.8	4.7	1.45	2.8	2.5	4.7	3.6	5.8	4.2	7.1	J_M			
7.42	10.72	10.72	8.22	8.22	14.32	14.32	23.44	23.44	34.74	34.82	M_2			
11	21	17	14	11	25	22	36	27	47	33	c	2.01	61	1.6
3.9	2.6	2.5	4.2	3.9	2.4	2.2	1.7	1.8	1.3	1.4	$n_{2\text{Eck}}$			
2203	1219	2531	938	2250	938	2016	938	2016	844	2016	$n_{2\text{th}}$			
1763	1219	1610	938	1760	938	1551	938	1421	844	1274	M_2			
											c	1.46	63	2.048
											$n_{2\text{Eck}}$			
											$n_{2\text{th}}$			
15	27	22	18	15	32	28	46	34	60	42	M_2			
3.6	2.4	2.3	3.9	3.6	2.2	2	1.6	1.6	1.2	1.3	c	1.46	72	2.048
1722	952	1978	733	1758	733	1575	733	1575	659	1575	$n_{2\text{Eck}}$			
1570	952	1436	733	1568	733	1390	733	1230	659	1103	$n_{2\text{th}}$			
											M_2			
											c	1.27	66	2.24
											$n_{2\text{Eck}}$			
											$n_{2\text{th}}$			
16	29	24	20	16	35	31	50	38	66	46	M_2			
3.6	2.4	2.3	3.9	3.5	2.2	2	1.6	1.6	1.2	1.3	c	1.27	79	2.24
1574	871	1808	670	1607	670	1440	670	1440	603	1440	$n_{2\text{Eck}}$			
1482	871	1359	670	1480	670	1313	670	1167	603	1053	$n_{2\text{th}}$			
											M_2			
											c	0.97	71	2.857
											$n_{2\text{Eck}}$			
											$n_{2\text{th}}$			
21	38	31									M_2			
3.3	2.2	2.1									c	0.97	91	2.857
1234	683	1418									$n_{2\text{Eck}}$			
1234	683	1166									$n_{2\text{th}}$			
			25	21	45	39	64	48	84	59	M_2			
			3.6	3.3	2.1	1.8	1.4	1.5	1.1	1.2	c	0.97	92	2.857
			525	1260	525	1129	525	1129	473	1129	$n_{2\text{Eck}}$			
			525	1257	525	1103	525	998	473	914	$n_{2\text{th}}$			
											M_2			
											c	0.74	74	3.5
											$n_{2\text{Eck}}$			
											$n_{2\text{th}}$			
25	46	38									M_2			
2.8	1.9	1.8									c	0.74	96	3.5
1007	557	1157									$n_{2\text{Eck}}$			
1007	557	1060									$n_{2\text{th}}$			
			31	25	55	48	79	59	103	72	M_2			
			3.3	3	1.9	1.7	1.3	1.4	1	1.1	c	0.74	105	3.5
			429	1029	429	921	429	921	386	921	$n_{2\text{Eck}}$			
			429	1026	429	921	429	913	386	833	$n_{2\text{th}}$			
											M_2			
											c	0.48	52	4.556
											$n_{2\text{Eck}}$			
											$n_{2\text{th}}$			
											M_2			
											c	0.48	78	4.556
											$n_{2\text{Eck}}$			
											$n_{2\text{th}}$			

$M \dots$ [Nm]
 $n \dots$ [min^{-1}]
 $J \dots$ [kgcm^2]

$P \dots$ [kW]
 $I \dots$ [A]
 i [-]
 c [-]

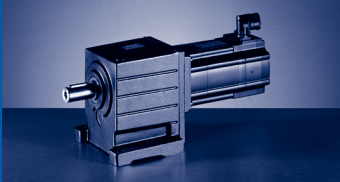

GST [Nm]

GST□□-□S (MCS)

$M_{2GN} \leq 105 \text{ Nm}$

GST06-1S				06FC41	06IC41	09DC41	09FC38	09HC41	09LC41	12DC20	12DC41	12HC15	12HC30	
				...500	...500	...500	...500	...500	...500	...500	...500	...500	...500	
i	M_{2GN}	J_G	M_1	1.2	1.5	2.3	3.1	3.8	4.5	5.5	4.3	10	8	
			n_1	4050	4050	4050	3750	4050	4050	1950	4050	1500	3000	
			I_{M230}	2.9	3.2	4.6	5	6.8	8.4	5.2	8.8	7.6	10.5	
			I_{M400}	1.5	1.6	2.3	2.5	3.4	4.2	2.6	4.5	3.8		
			P_N	0.51	0.64	1	1.2	1.6	1.9	1.1	1.8	1.6	2.5	
			J_M	0.25	0.33	1.13	1.53	1.93	2.83	4.12	4.12	7.42	7.42	
4.556	100	0.48	M_2							24	19	44	35	
			c							3.7	3.7	2.2	2.2	
			$n_{2 \text{ Eck}}$							428	889	329	659	
			$n_{2 \text{ th}}$							428	889	329	659	
5.667	54	0.36	M_2	6	8									
			c	5.8	4.7									
			$n_{2 \text{ Eck}}$	715	715									
			$n_{2 \text{ th}}$	715	715									
5.667	81	0.36	M_2			12	17	21	25					
			c			4.5	3.4	2.7	2.3					
			$n_{2 \text{ Eck}}$			715	662	715	715					
			$n_{2 \text{ th}}$			715	662	715	715					
5.667	104	0.36	M_2							30	23	55	44	
			c							3.1	3.1	1.9	1.9	
			$n_{2 \text{ Eck}}$							344	715	265	529	
			$n_{2 \text{ th}}$						344	715	265	529		
7.333	56	0.23	M_2	8	11									
			c	4.7	3.7									
			$n_{2 \text{ Eck}}$	552	552									
			$n_{2 \text{ th}}$	552	552									
7.333	83	0.23	M_2			16	22	27	32					
			c			3.6	2.8	2.2	1.8					
			$n_{2 \text{ Eck}}$			552	511	552	552					
			$n_{2 \text{ th}}$			552	511	552	552					
8.9	57	0.17	M_2	10	13									
			c	3.9	3.1									
			$n_{2 \text{ Eck}}$	455	455									
			$n_{2 \text{ th}}$	455	455									
8.9	84	0.17	M_2			20	27	33	39					
			c			3	2.3	1.8	1.5					
			$n_{2 \text{ Eck}}$			455	421	455	455					
			$n_{2 \text{ th}}$			455	421	455	455					
11.25	56	0.11	M_2	13	16									
			c	3.1	2.4									
			$n_{2 \text{ Eck}}$	360	360									
			$n_{2 \text{ th}}$	360	360									

$M \dots$ [Nm]
 $n \dots$ [min^{-1}]
 $J \dots$ [kgcm^2]

$P \dots$ [kW]
 $I \dots$ [A]
 $i \dots$ [-]
 $c \dots$ [-]

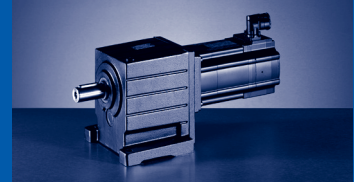

$M_{2GN} \leq 105 \text{ Nm}$

12HC35	12LC20	12LC41	14DC15	14DC36	14HC15	14HC32	14LC15	14LC32	14PC14	14PC32	GST06-1S			
...S00	...S00	...S00	...S00	...S00	...S00	...S00	...S00	...S00	...S00	...S00	M_1	J_G	M_{2GN}	i
7.5	13.5	11	9.2	7.5	16	14	23	17.2	30	21	n_1			
3525	1950	4050	1500	3600	1500	3225	1500	3225	1350	3225	I_{M230}			
	11.8										I_{M400}			
5.7	5.9	10.2	4.5	7.5	6.6	11.9	9.7	15	10.8	15.6	P_N			
2.8	2.8	4.7	1.45	2.8	2.5	4.7	3.6	5.8	4.2	7.1	J_M			
7.42	10.72	10.72	8.22	8.22	14.32	14.32	23.44	23.44	34.74	34.82	M_2			
33	60	49									c	0.48	100	4.556
774	428	889									$n_{2 \text{ Eck}}$			
774	428	848									$n_{2 \text{ th}}$			
											M_2			
											c	0.36	54	5.667
											$n_{2 \text{ Eck}}$			
											$n_{2 \text{ th}}$			
											M_2			
											c	0.36	81	5.667
											$n_{2 \text{ Eck}}$			
											$n_{2 \text{ th}}$			
41	75	61									M_2			
1.9	1.3	1.2									c	0.36	104	5.667
622	344	715									$n_{2 \text{ Eck}}$			
622	344	715									$n_{2 \text{ th}}$			
											M_2			
											c	0.23	56	7.333
											$n_{2 \text{ Eck}}$			
											$n_{2 \text{ th}}$			
											M_2			
											c	0.23	83	7.333
											$n_{2 \text{ Eck}}$			
											$n_{2 \text{ th}}$			
											M_2			
											c	0.17	57	8.9
											$n_{2 \text{ Eck}}$			
											$n_{2 \text{ th}}$			
											M_2			
											c	0.17	84	8.9
											$n_{2 \text{ Eck}}$			
											$n_{2 \text{ th}}$			
											M_2			
											c	0.11	56	11.25
											$n_{2 \text{ Eck}}$			
											$n_{2 \text{ th}}$			

M ... [Nm]
n ... [min⁻¹]
J ... [kgcm²]

P ... [kW]
I ... [A]
i [-]
c [-]

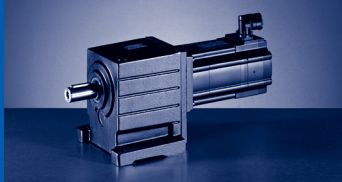

GST [Nm]

GST□□-□S (MCS)

$M_{2GN} \leq 366 \text{ Nm}$

GST06-2S				06FC41	06IC41	09DC41	09FC38	09HC41	09LC41	12DC20	12DC41	12HC15	12HC30
				...500	...500	...500	...500	...500	...500	...500	...500	...500	...500
i	M_{2GN}	J_G	M_1	1.2	1.5	2.3	3.1	3.8	4.5	5.5	4.3	10	8
			n_1	4050	4050	4050	3750	4050	4050	1950	4050	1500	3000
			I_{M230}	2.9	3.2	4.6	5	6.8	8.4	5.2	8.8	7.6	10.5
			I_{M400}	1.5	1.6	2.3	2.5	3.4	4.2	2.6	4.5	3.8	
			P_N	0.51	0.64	1	1.2	1.6	1.9	1.1	1.8	1.6	2.5
			J_M	0.25	0.33	1.13	1.53	1.93	2.83	4.12	4.12	7.42	7.42
3.033	166	2.72	M_2									28	22
			c									5.7	5.6
			$n_{2 \text{ Eck}}$									495	989
			$n_{2 \text{ th}}$								495	862	
3.333	174	2.61	M_2									31	25
			c									5.4	5.3
			$n_{2 \text{ Eck}}$									450	900
			$n_{2 \text{ th}}$								450	777	
4.16	191	2.51	M_2									39	31
			c									4.7	4.7
			$n_{2 \text{ Eck}}$									361	721
			$n_{2 \text{ th}}$								361	703	
4.571	200	2.41	M_2									43	34
			c									4.5	4.5
			$n_{2 \text{ Eck}}$									328	656
			$n_{2 \text{ th}}$								328	634	
5.324	161	1.76	M_2					19	22				
			c					5.9	5				
			$n_{2 \text{ Eck}}$					761	761				
			$n_{2 \text{ th}}$					663	643				
5.324	207	1.76	M_2									50	40
			c									4	4
			$n_{2 \text{ Eck}}$									282	564
			$n_{2 \text{ th}}$								282	564	
5.85	177	1.71	M_2					20	24				
			c					5.9	5				
			$n_{2 \text{ Eck}}$					692	692				
			$n_{2 \text{ th}}$					604	585				
5.85	222	1.71	M_2									55	44
			c									3.9	3.9
			$n_{2 \text{ Eck}}$									256	513
			$n_{2 \text{ th}}$								256	513	
6.4	185	1.47	M_2					22	27				
			c					5.6	4.8				
			$n_{2 \text{ Eck}}$					633	633				
			$n_{2 \text{ th}}$					564	547				
6.4	229	1.47	M_2									60	48
			c									3.7	3.7
			$n_{2 \text{ Eck}}$									234	469
			$n_{2 \text{ th}}$								234	469	
7.04	236	2.07	M_2							36	28	67	53
			c							5.8	5.8	3.5	3.4
			$n_{2 \text{ Eck}}$							277	575	213	426
			$n_{2 \text{ th}}$						277	432	213	390	
8.163	199	1.06	M_2				23	29	35				
			c				6	4.8	4				
			$n_{2 \text{ Eck}}$				459	496	496				
			$n_{2 \text{ th}}$				459	471	458				
8.163	252	1.06	M_2							42	33	77	62
			c							5.3	5.3	3.2	3.2
			$n_{2 \text{ Eck}}$							239	496	184	368
			$n_{2 \text{ th}}$						239	480	184	368	

$M \dots [\text{Nm}]$
 $n \dots [\text{min}^{-1}]$
 $J \dots [\text{kgcm}^2]$

$P \dots [\text{kW}]$
 $I \dots [\text{A}]$
 $i \dots [-]$
 $c \dots [-]$



$M_{2GN} \leq 366 \text{ Nm}$

12HC35	12LC20	12LC41	14DC15	14DC36	14HC15	14HC32	14LC15	14LC32	14PC14	14PC32	GST06-2S			
...S00	...S00	...S00	...S00	...S00	...S00	...S00	...S00	...S00	...S00	...S00	M_1	J_G	M_{2GN}	i
7.5	13.5	11	9.2	7.5	16	14	23	17.2	30	21	n_1			
3525	1950	4050	1500	3600	1500	3225	1500	3225	1350	3225	I_{M230}			
	11.8										I_{M400}			
5.7	5.9	10.2	4.5	7.5	6.6	11.9	9.7	15	10.8	15.6	P_N			
2.8	2.8	4.7	1.45	2.8	2.5	4.7	3.6	5.8	4.2	7.1	J_M			
7.42	10.72	10.72	8.22	8.22	14.32	14.32	23.44	23.44	34.74	34.82	M_2			
21	39	31		21	46	40	67	50	87	61	c	2.72	166	3.033
5.7	3.8	3.7		5.6	3.5	3.1	2.5	2.6	1.9	2.1	$n_{2 \text{ Eck}}$			
1162	643	1335		1187	495	1063	495	1063	445	1063	$n_{2 \text{ th}}$			
864	643	791		862	495	764	495	729	445	696	M_2			
23	42	35	28	23	50	44	73	55	96	67	c	2.61	174	3.333
5.4	3.7	3.5	5.9	5.4	3.4	3	2.3	2.4	1.8	2	$n_{2 \text{ Eck}}$			
1058	585	1215	450	1080	450	968	450	968	405	968	$n_{2 \text{ th}}$			
778	585	713	450	777	450	687	450	656	405	628	M_2			
29	53	43	36	29	63	56	92	69	120	84	c	2.51	191	4.16
4.8	3.2	3.1	5.2	4.7	3	2.6	2.1	2.1	1.6	1.8	$n_{2 \text{ Eck}}$			
847	469	974	361	865	361	775	361	775	325	775	$n_{2 \text{ th}}$			
705	469	646	361	704	361	623	361	595	325	545	M_2			
32	59	48	39	32	70	61	101	75	132	93	c	2.41	200	4.571
4.5	3.1	2.9	4.9	4.5	2.8	2.5	2	2	1.5	1.7	$n_{2 \text{ Eck}}$			
771	427	886	328	788	328	706	328	706	295	706	$n_{2 \text{ th}}$			
635	427	582	328	634	328	561	328	535	295	482	M_2			
											c	1.76	161	5.324
											$n_{2 \text{ Eck}}$			
											$n_{2 \text{ th}}$			
38	68	56	46	38	81	71	118	88	154	108	M_2			
4	2.7	2.6	4.4	4	2.5	2.2	1.8	1.8	1.3	1.5	c	1.76	207	5.324
662	366	761	282	676	282	606	282	606	254	606	$n_{2 \text{ Eck}}$			
617	366	566	282	617	282	546	282	505	254	450	$n_{2 \text{ th}}$			
											M_2			
											c	1.71	177	5.85
											$n_{2 \text{ Eck}}$			
											$n_{2 \text{ th}}$			
41	75	61	50	41	89	79	130	97	170	119	M_2			
3.9	2.7	2.6	4.3	3.9	2.4	2.2	1.7	1.8	1.3	1.4	c	1.71	222	5.85
603	333	692	256	615	256	551	256	551	231	551	$n_{2 \text{ Eck}}$			
559	333	512	256	558	256	494	256	452	231	404	$n_{2 \text{ th}}$			
											M_2			
											c	1.47	185	6.4
											$n_{2 \text{ Eck}}$			
											$n_{2 \text{ th}}$			
45	83	67	55	45	98	86	142	106	186	130	M_2			
3.7	2.5	2.4	4	3.7	2.3	2	1.6	1.7	1.2	1.4	c	1.47	229	6.4
551	305	633	234	563	234	504	234	504	211	504	$n_{2 \text{ Eck}}$			
522	305	479	234	522	234	463	234	417	211	375	$n_{2 \text{ th}}$			
50	91	74	61	50	108	95	156	117	205	143	M_2			
3.5	2.4	2.3	3.8	3.4	2.2	1.9	1.5	1.6	1.2	1.3	c	2.07	236	7.04
501	277	575	213	511	213	458	213	458	192	458	$n_{2 \text{ Eck}}$			
391	277	356	213	390	213	340	213	302	192	273	$n_{2 \text{ th}}$			
											M_2			
											c	1.06	199	8.163
											$n_{2 \text{ Eck}}$			
											$n_{2 \text{ th}}$			
58	106	86	71	58	125	110	181	136	237	166	M_2			
3.2	2.2	2.1	3.5	3.2	2	1.8	1.4	1.4	1.1	1.2	c	1.06	252	8.163
432	239	496	184	441	184	395	184	395	165	395	$n_{2 \text{ Eck}}$			
432	239	406	184	439	184	380	184	344	165	316	$n_{2 \text{ th}}$			

M ... [Nm]
n ... [min⁻¹]
J ... [kgcm²]

P ... [kW]
I ... [A]
i [-]
c [-]

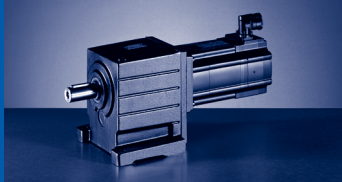

GST [Nm]

GST□□-□S (MCS)

$M_{2GN} \leq 366 \text{ Nm}$

GST06-2S				06FC41	06IC41	09DC41	09FC38	09HC41	09LC41	12DC20	12DC41	12HC15	12HC30
				...500	...500	...500	...500	...500	...500	...500	...500	...500	...500
i	M_{2GN}	J_G	M_1	1.2	1.5	2.3	3.1	3.8	4.5	5.5	4.3	10	8
			n_1	4050	4050	4050	3750	4050	4050	1950	4050	1500	3000
			I_{M230}	2.9	3.2	4.6	5	6.8	8.4	5.2	8.8	7.6	10.5
			I_{M400}	1.5	1.6	2.3	2.5	3.4	4.2	2.6	4.5	3.8	
			P_N	0.51	0.64	1	1.2	1.6	1.9	1.1	1.8	1.6	2.5
			J_M	0.25	0.33	1.13	1.53	1.93	2.83	4.12	4.12	7.42	7.42
9.01	261	1.5	M_2					32	38	46	36	86	69
			c					5.6	4.8	5	5	3	3
			$n_{2 \text{ Eck}}$					450	450	216	450	167	333
			$n_{2 \text{ th}}$					389	377	216	380	166	333
10	209	0.82	M_2				29	36	43				
			c				5.1	4.1	3.4				
			$n_{2 \text{ Eck}}$				375	405	405				
			$n_{2 \text{ th}}$				375	405	405				
10	269	0.82	M_2							51	40	95	76
			c							4.6	4.6	2.8	2.8
			$n_{2 \text{ Eck}}$							195	405	150	300
			$n_{2 \text{ th}}$							195	405	150	300
11.2	280	1.26	M_2					40	47	58	45	107	86
			c					4.9	4.1	4.3	4.3	2.6	2.6
			$n_{2 \text{ Eck}}$					362	362	174	362	134	268
			$n_{2 \text{ th}}$					314	304	174	307	134	268
12.571	295	0.96	M_2				36	45	53	65	51	120	96
			c				5.8	4.6	3.9	4	4	2.4	2.4
			$n_{2 \text{ Eck}}$				298	322	322	155	322	119	239
			$n_{2 \text{ th}}$				298	304	295	155	298	119	239
14.286	307	0.93	M_2				41	51	61	74	58	137	110
			c				5.3	4.2	3.5	3.7	3.7	2.2	2.2
			$n_{2 \text{ Eck}}$				263	284	284	137	284	105	210
			$n_{2 \text{ th}}$				263	264	256	137	258	105	210
15.4	318	0.75	M_2				44	55	65	80	62	148	118
			c				5.8	4.6	3.9	3.9	4	2.1	2.4
			$n_{2 \text{ Eck}}$				244	263	263	127	263	97	195
			$n_{2 \text{ th}}$				244	263	263	127	263	97	195
17.5	313	0.73	M_2				50	63	75	91	71	168	134
			c				5	4	3.3	3.4	3.5	1.8	2.1
			$n_{2 \text{ Eck}}$				214	231	231	111	231	86	171
			$n_{2 \text{ th}}$				214	231	231	111	231	86	171
20.044	336	0.46	M_2				58	72	86				
			c				4.7	3.7	3.1				
			$n_{2 \text{ Eck}}$				187	202	202				
			$n_{2 \text{ th}}$				187	202	202				
20.044	350	0.46	M_2							104	82	193	154
			c							3.3	3.4	1.8	2
			$n_{2 \text{ Eck}}$							97	202	75	150
			$n_{2 \text{ th}}$							97	202	75	150
22.778	315	0.45	M_2			49	66	82	98	120	93	220	176
			c			5.1	3.9	3.1	2.6	2.6	2.7	1.4	1.6
			$n_{2 \text{ Eck}}$			178	165	178	178	86	178	66	132
			$n_{2 \text{ th}}$			178	165	178	178	86	178	66	132
24.933	236	0.33	M_2		35								
			c		5.3								
			$n_{2 \text{ Eck}}$		162								
			$n_{2 \text{ th}}$		162								
24.933	349	0.33	M_2			53	73	90	107				
			c			5.1	3.9	3.1	2.6				
			$n_{2 \text{ Eck}}$			162	150	162	162				
			$n_{2 \text{ th}}$			162	150	162	162				

$M \dots [\text{Nm}]$
 $n \dots [\text{min}^{-1}]$
 $J \dots [\text{kgcm}^2]$

$P \dots [\text{kW}]$
 $I \dots [\text{A}]$
 $i \dots [-]$
 $c \dots [-]$

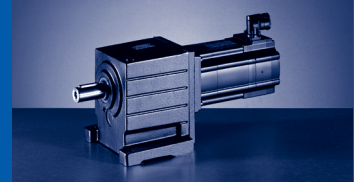

$M_{2GN} \leq 366 \text{ Nm}$

12HC35	12LC20	12LC41	14DC15	14DC36	14HC15	14HC32	14LC15	14LC32	14PC14	14PC32	GST06-2S			
...S00	...S00	...S00	...S00	...S00	...S00	...S00	...S00	...S00	...S00	...S00	M_1	J_G	M_{2GN}	i
7.5	13.5	11	9.2	7.5	16	14	23	17.2	30	21	n_1			
3525	1950	4050	1500	3600	1500	3225	1500	3225	1350	3225	I_{M230}			
	11.8										I_{M400}			
5.7	5.9	10.2	4.5	7.5	6.6	11.9	9.7	15	10.8	15.6	P_N			
2.8	2.8	4.7	1.45	2.8	2.5	4.7	3.6	5.8	4.2	7.1	J_M			
7.42	10.72	10.72	8.22	8.22	14.32	14.32	23.44	23.44	34.74	34.82	M_2			
64	117	95	79	64	139	122	200	150		183	c	1.5	261	9.01
3	2	2	3.2	3	1.9	1.7	1.3	1.4		1.1	$n_{2 \text{ Eck}}$			
391	216	450	167	400	167	358	167	358		358	$n_{2 \text{ th}}$			
344	216	312	166	343	166	283	166	253		229	M_2			
											c	0.82	209	10
											$n_{2 \text{ Eck}}$			
											$n_{2 \text{ th}}$			
71	130	106	87	71	154	135	223	166		204	M_2			
2.8	1.9	1.8	3	2.8	1.7	1.5	1.2	1.3		1	c	0.82	269	10
353	195	405	150	360	150	323	150	323		323	$n_{2 \text{ Eck}}$			
353	195	370	150	359	150	323	150	306		280	$n_{2 \text{ th}}$			
80	146	119	98	80	173	151	250	187			M_2			
2.6	1.8	1.7	2.8	2.6	1.6	1.4	1.1	1.2			c	1.26	280	11.2
315	174	362	134	321	134	288	134	288			$n_{2 \text{ Eck}}$			
278	174	240	134	278	134	220	134	199			$n_{2 \text{ th}}$			
90	164	133	110	90	194	170	280	210			M_2			
2.4	1.6	1.6	2.6	2.4	1.5	1.3	1.1	1.1			c	0.96	295	12.571
280	155	322	119	286	119	257	119	257			$n_{2 \text{ Eck}}$			
272	155	234	119	271	119	217	119	199			$n_{2 \text{ th}}$			
103	186	152	126	103	221	194					M_2			
2.2	1.5	1.4	2.4	2.2	1.4	1.2					c	0.93	307	14.286
247	137	284	105	252	105	226					$n_{2 \text{ Eck}}$			
235	137	197	105	235	105	184					$n_{2 \text{ th}}$			
110	201	163	136	110	238	208		257			M_2			
2.4	1.6	1.6	2.3	2.4	1.3	1.3		1.1			c	0.75	318	15.4
229	127	263	97	234	97	209		209			$n_{2 \text{ Eck}}$			
229	127	223	97	233	97	205		187			$n_{2 \text{ th}}$			
126	228	186	155	126	271	237					M_2			
2.1	1.4	1.4	2	2.1	1.2	1.2					c	0.73	313	17.5
201	111	231	86	206	86	184					$n_{2 \text{ Eck}}$			
201	111	183	86	205	86	169					$n_{2 \text{ th}}$			
											M_2			
											c	0.46	336	20.044
											$n_{2 \text{ Eck}}$			
											$n_{2 \text{ th}}$			
144	262	213									M_2			
2.1	1.3	1.3									c	0.46	350	20.044
176	97	202									$n_{2 \text{ Eck}}$			
176	97	186									$n_{2 \text{ th}}$			
165	298	243									M_2			
1.6	1.1	1.1									c	0.45	315	22.778
155	86	178									$n_{2 \text{ Eck}}$			
155	86	150									$n_{2 \text{ th}}$			
											M_2			
											c	0.33	236	24.933
											$n_{2 \text{ Eck}}$			
											$n_{2 \text{ th}}$			
											M_2			
											c	0.33	349	24.933
											$n_{2 \text{ Eck}}$			
											$n_{2 \text{ th}}$			

M ... [Nm]
n ... [min⁻¹]
J ... [kgcm²]

P ... [kW]
I ... [A]
i [-]
c [-]

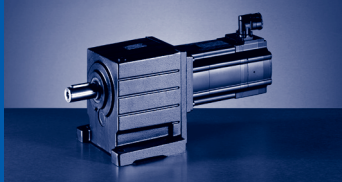

GST [Nm]

GST□□-□S (MCS)

$M_{2GN} \leq 366 \text{ Nm}$

GST06-2S				06FC41	06IC41	09DC41	09FC38	09HC41	09LC41	12DC20	12DC41	12HC15	12HC30
				...500	...500	...500	...500	...500	...500	...500	...500	...500	...500
i	M_{2GN}	J_G	M_1	1.2	1.5	2.3	3.1	3.8	4.5	5.5	4.3	10	8
			n_1	4050	4050	4050	3750	4050	4050	1950	4050	1500	3000
			I_{M230}	2.9	3.2	4.6	5	6.8	8.4	5.2	8.8	7.6	10.5
			I_{M400}	1.5	1.6	2.3	2.5	3.4	4.2	2.6	4.5	3.8	
			P_N	0.51	0.64	1	1.2	1.6	1.9	1.1	1.8	1.6	2.5
			J_M	0.25	0.33	1.13	1.53	1.93	2.83	4.12	4.12	7.42	7.42
24.933	360	0.33	M_2							131	102	241	192
			c							2.7	2.8	1.5	1.7
			$n_{2 \text{ Eck}}$							78	162	60	120
			$n_{2 \text{ th}}$						78	162	60	120	
28.333	268	0.33	M_2		39								
			c		5.3								
			$n_{2 \text{ Eck}}$		143								
			$n_{2 \text{ th}}$		143								
28.333	317	0.33	M_2			61	83	103	122	149	117	274	219
			c			4.1	3.1	2.5	2.1	2.1	2.2	1.2	1.3
			$n_{2 \text{ Eck}}$			143	132	143	143	69	143	53	106
			$n_{2 \text{ th}}$			143	132	143	143	69	143	53	106
32.267	245	0.22	M_2	36	45								
			c	5.3	4.3								
			$n_{2 \text{ Eck}}$	126	126								
			$n_{2 \text{ th}}$	126	126								
32.267	362	0.22	M_2			70	95	117	139				
			c			4.1	3.1	2.5	2.1				
			$n_{2 \text{ Eck}}$			126	116	126	126				
			$n_{2 \text{ th}}$			126	116	126	126				
36.667	278	0.22	M_2	41	52								
			c	5.3	4.3								
			$n_{2 \text{ Eck}}$	111	111								
			$n_{2 \text{ th}}$	110	110								
36.667	322	0.22	M_2			80	109	134	159				
			c			3.2	2.4	1.9	1.6				
			$n_{2 \text{ Eck}}$			111	102	111	111				
			$n_{2 \text{ th}}$			110	102	110	110				
39.16	247	0.16	M_2	44	55								
			c	4.4	3.5								
			$n_{2 \text{ Eck}}$	103	103								
			$n_{2 \text{ th}}$	103	103								
39.16	366	0.16	M_2			85	116	143	170				
			c			3.4	2.6	2.1	1.8				
			$n_{2 \text{ Eck}}$			103	96	103	103				
			$n_{2 \text{ th}}$			103	96	103	103				
44.5	281	0.16	M_2	50	63								
			c	4.9	3.9								
			$n_{2 \text{ Eck}}$	91	91								
			$n_{2 \text{ th}}$	91	91								
44.5	325	0.16	M_2			97	132	163	193				
			c			3	2.3	1.8	1.5				
			$n_{2 \text{ Eck}}$			91	84	91	91				
			$n_{2 \text{ th}}$			91	84	91	91				
49.5	245	0.11	M_2	56	71								
			c	3.8	3.1								
			$n_{2 \text{ Eck}}$	82	82								
			$n_{2 \text{ th}}$	82	82								
56.25	278	0.11	M_2	64	80								
			c	3.8	3.1								
			$n_{2 \text{ Eck}}$	72	72								
			$n_{2 \text{ th}}$	72	72								

$M \dots [\text{Nm}]$
 $n \dots [\text{min}^{-1}]$
 $J \dots [\text{kgcm}^2]$

$P \dots [\text{kW}]$
 $I \dots [\text{A}]$
 $i \dots [-]$
 $c \dots [-]$

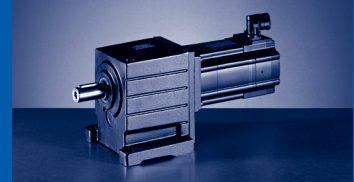

$M_{2GN} \leq 366 \text{ Nm}$

12HC35	12LC20	12LC41	14DC15	14DC36	14HC15	14HC32	14LC15	14LC32	14PC14	14PC32	GST06-2S			
...S00	...S00	...S00	...S00	...S00	...S00	...S00	...S00	...S00	...S00	...S00	M_1	J_G	M_{2GN}	i
7.5	13.5	11	9.2	7.5	16	14	23	17.2	30	21	n_1			
3525	1950	4050	1500	3600	1500	3225	1500	3225	1350	3225	I_{M230}			
	11.8										I_{M400}			
5.7	5.9	10.2	4.5	7.5	6.6	11.9	9.7	15	10.8	15.6	P_N			
2.8	2.8	4.7	1.45	2.8	2.5	4.7	3.6	5.8	4.2	7.1	J_M			
7.42	10.72	10.72	8.22	8.22	14.32	14.32	23.44	23.44	34.74	34.82	M_2			
180	326	266									c	0.33	360	24.933
141	78	162									$n_{2 \text{ Eck}}$			
141	78	162									$n_{2 \text{ th}}$			
											M_2			
											c	0.33	268	28.333
											$n_{2 \text{ Eck}}$			
											$n_{2 \text{ th}}$			
206											M_2			
1.3											c	0.33	317	28.333
124											$n_{2 \text{ Eck}}$			
124											$n_{2 \text{ th}}$			
											M_2			
											c	0.22	245	32.267
											$n_{2 \text{ Eck}}$			
											$n_{2 \text{ th}}$			
											M_2			
											c	0.22	362	32.267
											$n_{2 \text{ Eck}}$			
											$n_{2 \text{ th}}$			
											M_2			
											c	0.22	278	36.667
											$n_{2 \text{ Eck}}$			
											$n_{2 \text{ th}}$			
											M_2			
											c	0.22	322	36.667
											$n_{2 \text{ Eck}}$			
											$n_{2 \text{ th}}$			
											M_2			
											c	0.16	247	39.16
											$n_{2 \text{ Eck}}$			
											$n_{2 \text{ th}}$			
											M_2			
											c	0.16	366	39.16
											$n_{2 \text{ Eck}}$			
											$n_{2 \text{ th}}$			
											M_2			
											c	0.16	281	44.5
											$n_{2 \text{ Eck}}$			
											$n_{2 \text{ th}}$			
											M_2			
											c	0.16	325	44.5
											$n_{2 \text{ Eck}}$			
											$n_{2 \text{ th}}$			
											M_2			
											c	0.11	245	49.5
											$n_{2 \text{ Eck}}$			
											$n_{2 \text{ th}}$			
											M_2			
											c	0.11	278	56.25
											$n_{2 \text{ Eck}}$			
											$n_{2 \text{ th}}$			

$M \dots$ [Nm]
 $n \dots$ [min^{-1}]
 $J \dots$ [kgcm^2]

$P \dots$ [kW]
 $I \dots$ [A]
 i [-]
 c [-]

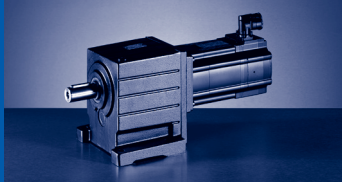

GST [Nm]

GST□□-□S (MCS)

$M_{2GN} \leq 375 \text{ Nm}$

GST06-3S				06CC41	06FC41	06IC41	09DC41	09FC38	09HC41	09LC41
				...500	...500	...500	...500	...500	...500	...500
i	M_{2GN}	J_G	M_1	0.6	1.2	1.5	2.3	3.1	3.8	4.5
			n_1	4050	4050	4050	4050	3750	4050	4050
			I_{M230}	2.6	2.9	3.2	4.6	5	6.8	8.4
			I_{M400}	1.3	1.5	1.6	2.3	2.5	3.4	4.2
			P_N	0.25	0.51	0.64	1	1.2	1.6	1.9
			J_M	0.17	0.25	0.33	1.13	1.53	1.93	2.83
39.2	321	0.36	M_2		43	54	84	115	141	168
			c		5.8	4.7	3	2.3	1.8	1.6
			$n_{2 \text{ Eck}}$		103	103	103	96	103	103
			$n_{2 \text{ th}}$		103	103	103	96	103	103
44	335	0.2	M_2			61	95	128	158	188
			c			4.8	3.1	2.4	1.9	1.6
			$n_{2 \text{ Eck}}$			92	92	85	92	92
			$n_{2 \text{ th}}$			92	92	85	92	92
51.022	325	0.32	M_2		56	71	110	150	184	219
			c		5	4	2.6	2	1.6	1.3
			$n_{2 \text{ Eck}}$		79	79	79	74	79	79
			$n_{2 \text{ th}}$		79	79	79	74	79	79
53.9	349	0.18	M_2		59	75	116	158	194	231
			c		5.1	4.1	2.7	2	1.6	1.4
			$n_{2 \text{ Eck}}$		75	75	75	70	75	75
			$n_{2 \text{ th}}$		75	75	75	70	75	75
67.76	365	0.11	M_2		75	95				
			c		4.3	3.4				
			$n_{2 \text{ Eck}}$		60	60				
			$n_{2 \text{ th}}$		60	60				
70.156	359	0.16	M_2		78	98	152	207	254	301
			c		4	3.2	2.1	1.6	1.3	1.1
			$n_{2 \text{ Eck}}$		58	58	58	54	58	58
			$n_{2 \text{ th}}$		58	58	58	53	58	58
80.952	332	0.2	M_2		91	114	177	239	294	
			c		3.2	2.6	1.7	1.3	1	
			$n_{2 \text{ Eck}}$		50	50	50	46	50	
			$n_{2 \text{ th}}$		50	50	50	46	50	
87.267	370	0.15	M_2		98	123	190	258	317	
			c		3.3	2.7	1.7	1.3	1.1	
			$n_{2 \text{ Eck}}$		46	46	46	43	46	
			$n_{2 \text{ th}}$		46	46	46	43	46	
99.167	336	0.15	M_2	54	112	140	217	294		
			c	5.3	2.7	2.1	1.4	1.1		
			$n_{2 \text{ Eck}}$	41	41	41	41	38		
			$n_{2 \text{ th}}$	41	41	41	41	38		
109.707	375	0.1	M_2	60	124	155				
			c	5.4	2.7	2.2				
			$n_{2 \text{ Eck}}$	37	37	37				
			$n_{2 \text{ th}}$	37	37	37				
124.667	339	0.1	M_2	69	141	177				
			c	4.3	2.2	1.7				
			$n_{2 \text{ Eck}}$	33	33	33				
			$n_{2 \text{ th}}$	32	32	32				
141.289	375	0.06	M_2	78	160	201				
			c	4.2	2.1	1.7				
			$n_{2 \text{ Eck}}$	29	29	29				
			$n_{2 \text{ th}}$	29	29	29				
160.556	342	0.06	M_2	90	183	229				
			c	3.4	1.7	1.3				
			$n_{2 \text{ Eck}}$	25	25	25				
			$n_{2 \text{ th}}$	25	25	25				

$M \dots$ [Nm]
 $n \dots$ [min^{-1}]
 $J \dots$ [kgcm^2]

$P \dots$ [kW]
 $I \dots$ [A]
 $i \dots$ [-]
 $c \dots$ [-]

GST [Nm]
GST□□-□S (MCS)



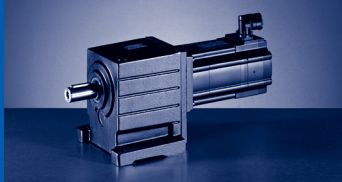

GST [Nm]

GST□□-□S (MCS)

$M_{2GN} \leq 196 \text{ Nm}$

GST07-1S				09DC41	09FC38	09HC41	09LC41	12DC20	12DC41	12HC15	12HC30	12HC35	12LC20	12LC41	14DC15	
				...500	...500	...500	...500	...500	...500	...500	...500	...500	...500	...500	...500	
i	M_{2GN}	J_G	M_1	2.3	3.1	3.8	4.5	5.5	4.3	10	8	7.5	13.5	11	9.2	
			n_1	4050	3750	4050	4050	1950	4050	1500	3000	3525	1950	4050	1500	
			I_{M230}	4.6	5	6.8	8.4	5.2	8.8	7.6	10.5		11.8			
			I_{M400}	2.3	2.5	3.4	4.2	2.6	4.5	3.8		5.7	5.9	10.2	4.5	
			P_N	1	1.2	1.6	1.9	1.1	1.8	1.6	2.5	2.8	2.8	4.7	1.45	
			J_M	1.13	1.53	1.93	2.83	4.12	4.12	7.42	7.42	7.42	10.72	10.72	8.22	
1.625	106	6.12	M_2 c $n_{2 \text{ Eck}}$ $n_{2 \text{ th}}$													
2	99	4.78	M_2 c $n_{2 \text{ Eck}}$ $n_{2 \text{ th}}$							19 5 750 750	15 5 1500 1422	14 5.1 1763 1425	26 3.4 975 975	21 3.3 2025 1303		
2	124	4.78	M_2 c $n_{2 \text{ Eck}}$ $n_{2 \text{ th}}$													
2.24	105	4.02	M_2 c $n_{2 \text{ Eck}}$ $n_{2 \text{ th}}$							21 4.8 670 670	17 4.7 1339 1306	16 4.8 1574 1308	29 3.2 871 871	24 3.1 1808 1199		
2.24	135	4.02	M_2 c $n_{2 \text{ Eck}}$ $n_{2 \text{ th}}$													
2.857	88	2.69	M_2 c $n_{2 \text{ Eck}}$ $n_{2 \text{ th}}$			10 5.9 1418 1243	12 5 1418 1206									
2.857	113	2.69	M_2 c $n_{2 \text{ Eck}}$ $n_{2 \text{ th}}$							27 4 525 525	22 4 1050 1050	20 4 1234 1158	37 2.7 683 683	30 2.6 1418 1062		
2.857	156	2.69	M_2 c $n_{2 \text{ Eck}}$ $n_{2 \text{ th}}$													
3.5	119	2.15	M_2 c $n_{2 \text{ Eck}}$ $n_{2 \text{ th}}$					18 5.7 557 557	14 5.8 1157 1093	34 3.5 429 429	27 3.4 857 857	25 3.5 1007 1000	46 2.3 557 557	37 2.3 1157 922		
3.5	172	2.15	M_2 c $n_{2 \text{ Eck}}$ $n_{2 \text{ th}}$												30 5.4 429 429	
4.556	96	1.37	M_2 c $n_{2 \text{ Eck}}$ $n_{2 \text{ th}}$		13 5.1 823 823	17 4.1 889 889	20 3.4 889 889									
4.556	124	1.37	M_2 c $n_{2 \text{ Eck}}$ $n_{2 \text{ th}}$					24 4.6 428 428	19 4.6 889 889	44 2.8 329 329	35 2.7 659 659	33 2.8 774 774	60 1.9 428 428	49 1.8 889 804		
4.556	186	1.37	M_2 c $n_{2 \text{ Eck}}$ $n_{2 \text{ th}}$												40 4.5 329 329	

$M \dots$ [Nm]
 $n \dots$ [min^{-1}]
 $J \dots$ [kgcm^2]

$P \dots$ [kW]
 $I \dots$ [A]
 $i \dots$ [-]
 $c \dots$ [-]



$M_{2GN} \leq 196 \text{ Nm}$

14DC36	14HC15	14HC32	14LC15	14LC32	14PC14	14PC32	19FC14	19FC30	19JC14	19JC30	19PC14	19PC30	GST07-1S			
...500	...500	...500	...500	...500	...500	...500	...500	...500	...500	...500	...500	...500	M_1	J_G	M_{2GN}	i
7.5	16	14	23	17.2	30	21	27	21	40	29	51	32	n_1			
3600	1500	3225	1500	3225	1350	3225	1425	3000	1425	3000	1350	3000	I_{M230}			
7.5	6.6	11.9	9.7	15	10.8	15.6	8.6	14	12.3	18.5	14.3	19	I_{M400}			
2.8	2.5	4.7	3.6	5.8	4.2	7.1	4	6.6	6	9.1	7.2	10	P_N			
8.22	14.32	14.32	23.44	23.44	34.74	34.82	65.12	65.04	105.04	105.12	160.12	160.04	J_M			
	25	22	36	27	47	33	43	33	64	46	81	51	M_2			
	4.1	3.7	2.9	3	2.2	2.5	2.5	2.5	1.7	1.8	1.3	1.6	c	6.12	106	1.625
	923	1985	923	1985	831	1985	877	1846	877	1846	831	1846	$n_{2 \text{ Eck}}$			
	923	1451	923	1387	831	1324	877	1331	877	1196	831	1128	$n_{2 \text{ th}}$			
													M_2			
													c	4.78	99	2
													$n_{2 \text{ Eck}}$			
													$n_{2 \text{ th}}$			
	31	27	45	33	58	41	52	41	78	57	100	63	M_2			
	3.9	3.5	2.7	2.8	2.1	2.3	2.3	2.4	1.6	1.7	1.2	1.6	c	4.78	124	2
	750	1613	750	1613	675	1613	713	1500	713	1500	675	1500	$n_{2 \text{ Eck}}$			
	750	1319	750	1260	675	1203	713	1105	713	1065	675	1006	$n_{2 \text{ th}}$			
													M_2			
													c	4.02	105	2.24
													$n_{2 \text{ Eck}}$			
													$n_{2 \text{ th}}$			
	34	30	50	37	65	46	59	46	88	64	112	70	M_2			
	3.8	3.4	2.7	2.8	2	2.3	2.3	2.3	1.5	1.7	1.2	1.5	c	4.02	135	2.24
	670	1440	670	1440	603	1440	636	1339	636	1339	603	1339	$n_{2 \text{ Eck}}$			
	670	1220	670	1167	603	1117	636	987	636	984	603	932	$n_{2 \text{ th}}$			
													M_2			
													c	2.69	88	2.857
													$n_{2 \text{ Eck}}$			
													$n_{2 \text{ th}}$			
													M_2			
													c	2.69	113	2.857
													$n_{2 \text{ Eck}}$			
													$n_{2 \text{ th}}$			
20	44	39	64	48	84	58							M_2			
5.5	3.5	3.1	2.4	2.5	1.9	2.1							c	2.69	156	2.857
1260	525	1129	525	1129	473	1129							$n_{2 \text{ Eck}}$			
1229	525	1098	525	1051	473	1007							$n_{2 \text{ th}}$			
													M_2			
													c	2.15	119	3.5
													$n_{2 \text{ Eck}}$			
													$n_{2 \text{ th}}$			
25	54	47	78	59	103	72							M_2			
5	3.1	2.8	2.2	2.3	1.7	1.8							c	2.15	172	3.5
1029	429	921	429	921	386	921							$n_{2 \text{ Eck}}$			
1026	429	921	429	921	386	865							$n_{2 \text{ th}}$			
													M_2			
													c	1.37	96	4.556
													$n_{2 \text{ Eck}}$			
													$n_{2 \text{ th}}$			
													M_2			
													c	1.37	124	4.556
													$n_{2 \text{ Eck}}$			
													$n_{2 \text{ th}}$			
33	71	62	102	77	134	94							M_2			
4.1	2.6	2.3	1.8	1.9	1.4	1.5							c	1.37	186	4.556
790	329	708	329	708	296	708							$n_{2 \text{ Eck}}$			
788	329	708	329	708	296	708							$n_{2 \text{ th}}$			

$M \dots$ [Nm]
 $n \dots$ [min^{-1}]
 $J \dots$ [kgcm^2]

$P \dots$ [kW]
 $I \dots$ [A]
 i [-]
 c [-]

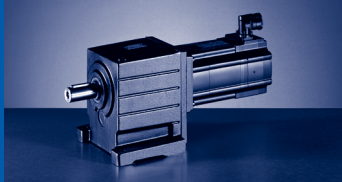

GST [Nm]

GST□□-□S (MCS)

$M_{2GN} \leq 196 \text{ Nm}$

GST07-1S				09DC41	09FC38	09HC41	09LC41	12DC20	12DC41	12HC15	12HC30	12HC35	12LC20	12LC41	14DC15	
				...500	...500	...500	...500	...500	...500	...500	...500	...500	...500	...500	...500	
i	M_{2GN}	J_G	M_1	2.3	3.1	3.8	4.5	5.5	4.3	10	8	7.5	13.5	11	9.2	
			n_1	4050	3750	4050	4050	1950	4050	1500	3000	3525	1950	4050	1500	
			I_{M230}	4.6	5	6.8	8.4	5.2	8.8	7.6	10.5		11.8			
			I_{M400}	2.3	2.5	3.4	4.2	2.6	4.5	3.8		5.7	5.9	10.2	4.5	
			P_N	1	1.2	1.6	1.9	1.1	1.8	1.6	2.5	2.8	2.8	4.7	1.45	
			J_M	1.13	1.53	1.93	2.83	4.12	4.12	7.42	7.42	7.42	10.72	10.72	8.22	
5.583	101	1.05	M_2	12	16	20	24									
			c	5.7	4.4	3.5	2.9									
			$n_{2 \text{ Eck}}$	725	672	725	725									
			$n_{2 \text{ th}}$	725	672	725	725									
5.583	130	1.05	M_2					29	23	54	43	41	74	60		
			c					3.9	4	2.4	2.4	2.4	1.6	1.5		
			$n_{2 \text{ Eck}}$					349	725	269	537	631	349	725		
			$n_{2 \text{ th}}$					349	725	269	537	631	349	682		
5.583	196	1.05	M_2												49	
			c												3.9	
			$n_{2 \text{ Eck}}$												269	
			$n_{2 \text{ th}}$												269	
7.333	104	0.66	M_2	16	22	27	32									
			c	4.5	3.4	2.7	2.3									
			$n_{2 \text{ Eck}}$	552	511	552	552									
			$n_{2 \text{ th}}$	552	511	552	552									
7.333	134	0.66	M_2					39	30	72	57	54	97	79		
			c					3.1	3.1	1.9	1.8	1.9	1.3	1.2		
			$n_{2 \text{ Eck}}$					266	552	205	409	481	266	552		
			$n_{2 \text{ th}}$					266	552	205	409	481	266	552		
8.9	105	0.49	M_2	20	27	33	39									
			c	3.7	2.9	2.3	1.9									
			$n_{2 \text{ Eck}}$	455	421	455	455									
			$n_{2 \text{ th}}$	455	421	455	455									
8.9	135	0.49	M_2					47	37	87	70	65	118	96		
			c					2.6	2.6	1.5	1.5	1.6	1.1	1		
			$n_{2 \text{ Eck}}$					219	455	169	337	396	219	455		
			$n_{2 \text{ th}}$					219	455	169	337	396	219	455		
11.25	106	0.32	M_2	25	34	42	50									
			c	3	2.3	1.8	1.5									
			$n_{2 \text{ Eck}}$	360	333	360	360									
			$n_{2 \text{ th}}$	360	333	360	360									

M ... [Nm]
 n ... [min^{-1}]
 J ... [kgcm^2]

P ... [kW]
 I ... [A]
 i [-]
 c [-]

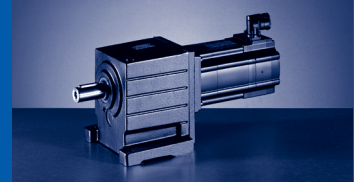

$M_{2GN} \leq 196 \text{ Nm}$

14DC36	14HC15	14HC32	14LC15	14LC32	14PC14	14PC32	19FC14	19FC30	19JC14	19JC30	19PC14	19PC30	GST07-1S			
...S00	...S00	...S00	...S00	...S00	...S00	...S00	...S00	...S00	...S00	...S00	...S00	...S00	M_1	J_G	M_{2GN}	i
7.5	16	14	23	17.2	30	21	27	21	40	29	51	32	n_1			
3600	1500	3225	1500	3225	1350	3225	1425	3000	1425	3000	1350	3000	I_{M230}			
7.5	6.6	11.9	9.7	15	10.8	15.6	8.6	14	12.3	18.5	14.3	19	I_{M400}			
2.8	2.5	4.7	3.6	5.8	4.2	7.1	4	6.6	6	9.1	7.2	10	P_N			
8.22	14.32	14.32	23.44	23.44	34.74	34.82	65.12	65.04	105.04	105.12	160.12	160.04	J_M			
													M_2 c	1.05	101	5.583
													n_2 Eck			
													n_2 th			
													M_2 c	1.05	130	5.583
													n_2 Eck			
													n_2 th			
40	87	76	126	94	165	115							M_2 c	1.05	196	5.583
3.6	2.2	2	1.6	1.6	1.2	1.3							n_2 Eck			
645	269	578	269	578	242	578							n_2 th			
643	269	578	269	578	242	578							M_2 c	0.66	104	7.333
													n_2 Eck			
													n_2 th			
													M_2 c	0.66	134	7.333
													n_2 Eck			
													n_2 th			
													M_2 c	0.49	105	8.9
													n_2 Eck			
													n_2 th			
													M_2 c	0.49	135	8.9
													n_2 Eck			
													n_2 th			
													M_2 c	0.32	106	11.25
													n_2 Eck			
													n_2 th			

M ... [Nm]
n ... [min⁻¹]
J ... [kgcm²]

P ... [kW]
I ... [A]
i [-]
c [-]

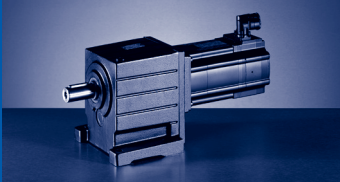

GST [Nm]

GST□□-□S (MCS)

$M_{2GN} \leq 706 \text{ Nm}$

GST07-2S				09DC41	09FC38	09HC41	09LC41	12DC20	12DC41	12HC15	12HC30	12HC35	12LC20	12LC41	14DC15
				...500	...500	...500	...500	...500	...500	...500	...500	...500	...500	...500	...500
i	M_{2GN}	J_G	M_1	2.3	3.1	3.8	4.5	5.5	4.3	10	8	7.5	13.5	11	9.2
			n_1	4050	3750	4050	4050	1950	4050	1500	3000	3525	1950	4050	1500
			I_{M230}	4.6	5	6.8	8.4	5.2	8.8	7.6	10.5		11.8		
			I_{M400}	2.3	2.5	3.4	4.2	2.6	4.5	3.8		5.7	5.9	10.2	4.5
			P_N	1	1.2	1.6	1.9	1.1	1.8	1.6	2.5	2.8	2.8	4.7	1.45
			J_M	1.13	1.53	1.93	2.83	4.12	4.12	7.42	7.42	7.42	10.72	10.72	8.22
3.048	304	8.2	M_2												
			c												
			n_2 Eck												
			n_2 th												
3.048	351	8.2	M_2												
			c												
			n_2 Eck												
			n_2 th												
3.35	334	7.92	M_2												
			c												
			n_2 Eck												
			n_2 th												
3.35	367	7.92	M_2												
			c												
			n_2 Eck												
			n_2 th												
4.225	373	7.65	M_2												
			c												
			n_2 Eck												
			n_2 th												
4.225	398	7.65	M_2												
			c												
			n_2 Eck												
			n_2 th												
4.643	410	7.39	M_2												
			c												
			n_2 Eck												
			n_2 th												
4.643	414	7.39	M_2												
			c												
			n_2 Eck												
			n_2 th												
5.2	254	5.64	M_2							48	39	36	66	54	
			c							5	5	5.1	3.4	3.3	
			n_2 Eck							289	577	678	375	779	
			n_2 th							288	547	548	375	501	
5.2	399	5.64	M_2												
			c												
			n_2 Eck												
			n_2 th												
5.2	427	5.64	M_2												
			c												
			n_2 Eck												
			n_2 th												
5.714	279	5.46	M_2							53	43	40	73	60	
			c							5	5	5.1	3.4	3.3	
			n_2 Eck							263	525	617	341	709	
			n_2 th							263	498	499	341	456	
5.714	438	5.46	M_2												
			c												
			n_2 Eck												
			n_2 th												

$M \dots$ [Nm]
 $n \dots$ [min^{-1}]
 $J \dots$ [kgcm^2]

$P \dots$ [kW]
 $I \dots$ [A]
 i [-]
 c [-]

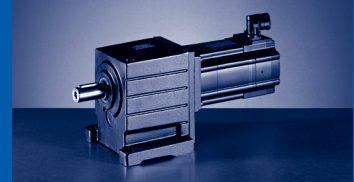

$M_{2GN} \leq 706 \text{ Nm}$

14DC36	14HC15	14HC32	14LC15	14LC32	14PC14	14PC32	19FC14	19FC30	19JC14	19JC30	19PC14	19PC30	GST07-2S			
...500	...500	...500	...500	...500	...500	...500	...500	...500	...500	...500	...500	...500	M_1	J_G	M_{2GN}	i
7.5	16	14	23	17.2	30	21	27	21	40	29	51	32	n_1			
3600	1500	3225	1500	3225	1350	3225	1425	3000	1425	3000	1350	3000	I_{M230}			
7.5	6.6	11.9	9.7	15	10.8	15.6	8.6	14	12.3	18.5	14.3	19	I_{M400}			
2.8	2.5	4.7	3.6	5.8	4.2	7.1	4	6.6	6	9.1	7.2	10	P_N			
8.22	14.32	14.32	23.44	23.44	34.74	34.82	65.12	65.04	105.04	105.12	160.12	160.04	J_M			
		39	66	49	87	60							M_2			
		5.7	4.5	4.6	3.4	3.8							c	8.2	304	3.048
		1058	492	1058	443	1058							$n_{2 \text{ Eck}}$			
		738	492	706	443	675							$n_{2 \text{ th}}$			
							77	60	116	84	149	93	M_2			
							4.4	4.5	3	3.3	2.3	3	c	8.2	351	3.048
							468	984	468	984	443	984	$n_{2 \text{ Eck}}$			
							467	701	467	652	443	636	$n_{2 \text{ th}}$			
		43	72	54	95	66							M_2			
		5.7	4.5	4.6	3.4	3.8							c	7.92	334	3.35
		963	448	963	403	963							$n_{2 \text{ Eck}}$			
		671	448	643	403	615							$n_{2 \text{ th}}$			
							85	66	128	92	164	102	M_2			
							4.2	4.3	2.8	3.1	2.2	2.8	c	7.92	367	3.35
							425	896	425	896	403	896	$n_{2 \text{ Eck}}$			
							425	631	425	586	403	572	$n_{2 \text{ th}}$			
	62	55	91	68	120	84							M_2			
	5.7	5	4	4.1	3	3.4							c	7.65	373	4.225
	355	763	355	763	320	763							$n_{2 \text{ Eck}}$			
	355	596	355	571	320	547							$n_{2 \text{ th}}$			
							108	84	162	117	207	129	M_2			
							3.6	3.7	2.4	2.7	1.9	2.4	c	7.65	398	4.225
							337	710	337	710	320	710	$n_{2 \text{ Eck}}$			
							337	523	337	519	320	507	$n_{2 \text{ th}}$			
	69	60	100	75	132	92							M_2			
	5.7	5	4	4.1	3	3.4							c	7.39	410	4.643
	323	695	323	695	291	695							$n_{2 \text{ Eck}}$			
	323	543	323	520	291	498							$n_{2 \text{ th}}$			
							119	92	178	129	228	142	M_2			
							3.4	3.5	2.3	2.5	1.8	2.3	c	7.39	414	4.643
							307	646	307	646	291	646	$n_{2 \text{ Eck}}$			
							307	476	307	466	291	456	$n_{2 \text{ th}}$			
													M_2			
													c	5.64	254	5.2
													$n_{2 \text{ Eck}}$			
													$n_{2 \text{ th}}$			
	77	68	113	84	149	104							M_2			
	4.9	4.4	3.4	3.6	2.6	2.9							c	5.64	399	5.2
	289	620	289	620	260	620							$n_{2 \text{ Eck}}$			
	288	532	288	510	260	488							$n_{2 \text{ th}}$			
							133	104	199	144	256	160	M_2			
							3.1	3.2	2.1	2.3	1.7	2.1	c	5.64	427	5.2
							274	577	274	577	260	577	$n_{2 \text{ Eck}}$			
							274	425	274	425	260	425	$n_{2 \text{ th}}$			
													M_2			
													c	5.46	279	5.714
													$n_{2 \text{ Eck}}$			
													$n_{2 \text{ th}}$			
	85	75	124	93	164	114							M_2			
	4.9	4.4	3.4	3.6	2.6	2.9							c	5.46	438	5.714
	263	564	263	564	236	564							$n_{2 \text{ Eck}}$			
	263	484	263	464	236	444							$n_{2 \text{ th}}$			

M ... [Nm]
n ... [min⁻¹]
J ... [kgcm²]

P ... [kW]
I ... [A]
i [-]
c [-]

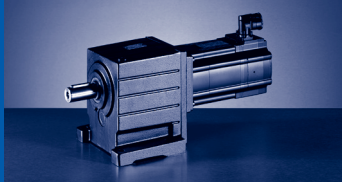

GST [Nm]

GST□□-□S (MCS)

$M_{2GN} \leq 706 \text{ Nm}$

GST07-2S				09DC41	09FC38	09HC41	09LC41	12DC20	12DC41	12HC15	12HC30	12HC35	12LC20	12LC41	14DC15
				...500	...500	...500	...500	...500	...500	...500	...500	...500	...500	...500	...500
i	M_{2GN}	J_G	M_1	2.3	3.1	3.8	4.5	5.5	4.3	10	8	7.5	13.5	11	9.2
			n_1	4050	3750	4050	4050	1950	4050	1500	3000	3525	1950	4050	1500
			I_{M230}	4.6	5	6.8	8.4	5.2	8.8	7.6	10.5		11.8		
			I_{M400}	2.3	2.5	3.4	4.2	2.6	4.5	3.8		5.7	5.9	10.2	4.5
			P_N	1	1.2	1.6	1.9	1.1	1.8	1.6	2.5	2.8	2.8	4.7	1.45
			J_M	1.13	1.53	1.93	2.83	4.12	4.12	7.42	7.42	7.42	10.72	10.72	8.22
5.714	448	5.46	M_2 c $n_{2 \text{ Eck}}$ $n_{2 \text{ th}}$												
6.4	296	4.49	M_2 c $n_{2 \text{ Eck}}$ $n_{2 \text{ th}}$							60 4.8	48 4.7	45 4.8	82 3.2	67 3.1	
6.4	460	4.49	M_2 c $n_{2 \text{ Eck}}$ $n_{2 \text{ th}}$							234	469	551	305	633	
6.4	463	4.49	M_2 c $n_{2 \text{ Eck}}$ $n_{2 \text{ th}}$							234	457	458	305	420	
7.15	489	6.27	M_2 c $n_{2 \text{ Eck}}$ $n_{2 \text{ th}}$												
8.125	539	6.04	M_2 c $n_{2 \text{ Eck}}$ $n_{2 \text{ th}}$												
8.8	430	4.73	M_2 c $n_{2 \text{ Eck}}$ $n_{2 \text{ th}}$							82 5	65 5	61 5.1	112 3.4	92 3.3	
8.8	527	4.73	M_2 c $n_{2 \text{ Eck}}$ $n_{2 \text{ th}}$							171	341	401	222	460	
8.8	527	4.73	M_2 c $n_{2 \text{ Eck}}$ $n_{2 \text{ th}}$							170	323	324	222	296	
9.856	456	3.9	M_2 c $n_{2 \text{ Eck}}$ $n_{2 \text{ th}}$							92 4.8	74 4.7	69 4.8	126 3.2	103 3.1	
9.856	456	3.9	M_2 c $n_{2 \text{ Eck}}$ $n_{2 \text{ th}}$							152	304	358	198	411	
9.856	549	3.9	M_2 c $n_{2 \text{ Eck}}$ $n_{2 \text{ th}}$							152	297	297	198	273	
11.2	518	3.78	M_2 c $n_{2 \text{ Eck}}$ $n_{2 \text{ th}}$							104 4.8	84 4.7	78 4.8	143 3.2	117 3.1	
11.2	518	3.78	M_2 c $n_{2 \text{ Eck}}$ $n_{2 \text{ th}}$							134	268	315	174	362	
11.2	598	3.78	M_2 c $n_{2 \text{ Eck}}$ $n_{2 \text{ th}}$							134	261	262	174	240	
12.571	380	2.86	M_2 c $n_{2 \text{ Eck}}$ $n_{2 \text{ th}}$			44 5.9 322 283	53 5 322 274								95 6 134 134

$M \dots [\text{Nm}]$
 $n \dots [\text{min}^{-1}]$
 $J \dots [\text{kgcm}^2]$

$P \dots [\text{kW}]$
 $I \dots [\text{A}]$
 $i \dots [-]$
 $c \dots [-]$

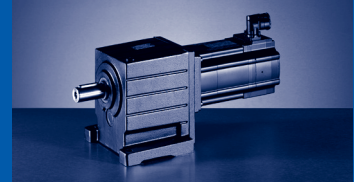

$M_{2GN} \leq 706 \text{ Nm}$

14DC36	14HC15	14HC32	14LC15	14LC32	14PC14	14PC32	19FC14	19FC30	19JC14	19JC30	19PC14	19PC30	GST07-2S			
...S00	...S00	...S00	...S00	...S00	...S00	...S00	...S00	...S00	...S00	...S00	...S00	...S00	M_1	J_G	M_{2GN}	i
7.5	16	14	23	17.2	30	21	27	21	40	29	51	32	n_1			
3600	1500	3225	1500	3225	1350	3225	1425	3000	1425	3000	1350	3000	I_{M230}			
													I_{M400}			
7.5	6.6	11.9	9.7	15	10.8	15.6	8.6	14	12.3	18.5	14.3	19	P_N			
2.8	2.5	4.7	3.6	5.8	4.2	7.1	4	6.6	6	9.1	7.2	10	J_M			
8.22	14.32	14.32	23.44	23.44	34.74	34.82	65.12	65.04	105.04	105.12	160.12	160.04	M_2			
							147	114	219	159	281	176	c	5.46	448	5.714
							3	3.1	2	2.2	1.6	2	$n_{2 \text{ Eck}}$			
							249	525	249	525	236	525	$n_{2 \text{ th}}$			
							249	387	249	387	236	387	M_2			
													c	4.49	296	6.4
													$n_{2 \text{ Eck}}$			
													$n_{2 \text{ th}}$			
	96	84	140	104	183	128							M_2			
	4.6	4.1	3.2	3.3	2.5	2.7							c	4.49	460	6.4
	234	504	234	504	211	504							$n_{2 \text{ Eck}}$			
	234	444	234	426	211	408							$n_{2 \text{ th}}$			
							165	128	246	178	315	197	M_2			
							2.8	2.8	1.9	2	1.5	1.9	c	4.49	463	6.4
							223	469	223	469	211	469	$n_{2 \text{ Eck}}$			
							223	345	223	345	211	345	$n_{2 \text{ th}}$			
	107	94	156	117	205	143	184	143	275	199	352	220	M_2			
	4.4	3.9	3.1	3.2	2.4	2.6	2.6	2.7	1.8	1.9	1.4	1.8	c	6.27	489	7.15
	210	451	210	451	189	451	199	420	199	420	189	420	$n_{2 \text{ Eck}}$			
	210	334	210	319	189	305	199	307	199	282	189	266	$n_{2 \text{ th}}$			
	122	107	178	133	233	163	209	163	313	227	401	250	M_2			
	4.3	3.8	3	3.1	2.3	2.5	2.5	2.6	1.7	1.9	1.3	1.7	c	6.04	539	8.125
	185	397	185	397	166	397	175	369	175	369	166	369	$n_{2 \text{ Eck}}$			
	185	292	185	279	166	267	175	268	175	244	166	230	$n_{2 \text{ th}}$			
													M_2			
													c	4.73	430	8.8
													$n_{2 \text{ Eck}}$			
													$n_{2 \text{ th}}$			
	133	117	193	144	253	177	227	177	340	246	434	272	M_2			
	3.9	3.4	2.7	2.8	2.1	2.3	2.3	2.3	1.5	1.7	1.2	1.5	c	4.73	527	8.8
	171	367	171	367	153	367	162	341	162	341	153	341	$n_{2 \text{ Eck}}$			
	170	299	170	285	153	272	162	251	162	240	153	226	$n_{2 \text{ th}}$			
													M_2			
													c	3.9	456	9.856
													$n_{2 \text{ Eck}}$			
													$n_{2 \text{ th}}$			
68	149	131	217	162	284	198	255	198	381	276	487	305	M_2			
5.7	3.6	3.2	2.5	2.6	1.9	2.1	2.1	2.2	1.4	1.6	1.1	1.4	c	3.9	549	9.856
365	152	327	152	327	137	327	145	304	145	304	137	304	$n_{2 \text{ Eck}}$			
308	152	274	152	262	137	250	145	224	145	216	137	205	$n_{2 \text{ th}}$			
													M_2			
													c	3.78	518	11.2
													$n_{2 \text{ Eck}}$			
													$n_{2 \text{ th}}$			
78	169	149	246	184	323	226	290	226	433	313	554	346	M_2			
5.5	3.4	3.1	2.4	2.5	1.8	2	2	2.1	1.4	1.5	1.1	1.4	c	3.78	598	11.2
321	134	288	134	288	121	288	127	268	127	268	121	268	$n_{2 \text{ Eck}}$			
269	134	239	134	228	121	218	127	197	127	186	121	177	$n_{2 \text{ th}}$			
													M_2			
													c	2.86	380	12.571
													$n_{2 \text{ Eck}}$			
													$n_{2 \text{ th}}$			

$M \dots$ [Nm]
 $n \dots$ [min^{-1}]
 $J \dots$ [kgcm^2]

$P \dots$ [kW]
 $I \dots$ [A]
 i [-]
 c [-]

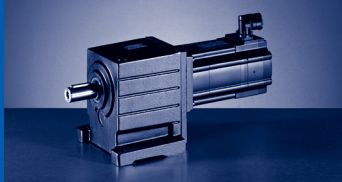

GST [Nm]

GST□□-□S (MCS)

$M_{2GN} \leq 706 \text{ Nm}$

GST07-2S				09DC41	09FC38	09HC41	09LC41	12DC20	12DC41	12HC15	12HC30	12HC35	12LC20	12LC41	14DC15			
				...500	...500	...500	...500	...500	...500	...500	...500	...500	...500	...500	...500			
i	M_{2GN}	J_G	M_1	2.3	3.1	3.8	4.5	5.5	4.3	10	8	7.5	13.5	11	9.2			
			n_1	4050	3750	4050	4050	1950	4050	1500	3000	3525	1950	4050	1500			
			I_{M230}	4.6	5	6.8	8.4	5.2	8.8	7.6	10.5		11.8					
			I_{M400}	2.3	2.5	3.4	4.2	2.6	4.5	3.8		5.7	5.9	10.2	4.5			
			P_N	1	1.2	1.6	1.9	1.1	1.8	1.6	2.5	2.8	2.8	4.7	1.45			
			J_M	1.13	1.53	1.93	2.83	4.12	4.12	7.42	7.42	7.42	10.72	10.72	8.22			
12.571	489	2.86	M_2							118	95	89	162	132				
			c								4	4	4	2.7	2.6			
			$n_{2 \text{ Eck}}$									119	239	280	155	322		
			$n_{2 \text{ th}}$									119	239	263	155	241		
12.571	601	2.86	M_2												107			
			c													5.4		
			$n_{2 \text{ Eck}}$														119	
			$n_{2 \text{ th}}$														119	
14.286	432	2.79	M_2			50	60											
			c			5.9	5											
			$n_{2 \text{ Eck}}$			284	284											
			$n_{2 \text{ th}}$			249	241											
14.286	556	2.79	M_2							134	107	101	184	150				
			c								4	4	4	2.7	2.6			
			$n_{2 \text{ Eck}}$								105	210	247	137	284			
			$n_{2 \text{ th}}$								105	210	232	137	212			
14.286	642	2.79	M_2												122			
			c													5		
			$n_{2 \text{ Eck}}$														105	
			$n_{2 \text{ th}}$														105	
15.4	515	2.26	M_2							146	116	109	198	162				
			c								3.5	3.9	3.9	2.6	2.6			
			$n_{2 \text{ Eck}}$								97	195	229	127	263			
			$n_{2 \text{ th}}$								97	195	229	127	215			
15.4	644	2.26	M_2												132			
			c													4.7		
			$n_{2 \text{ Eck}}$														97	
			$n_{2 \text{ th}}$														97	
17.5	585	2.21	M_2							166	132	124	226	184				
			c								3.5	3.9	3.9	2.6	2.6			
			$n_{2 \text{ Eck}}$								86	171	201	111	231			
			$n_{2 \text{ th}}$								86	171	201	111	189			
17.5	680	2.21	M_2												151			
			c													4.4		
			$n_{2 \text{ Eck}}$														86	
			$n_{2 \text{ th}}$														86	
20.044	418	1.38	M_2		57	71	85											
			c		5.8	4.6	3.9											
			$n_{2 \text{ Eck}}$		187	202	202											
			$n_{2 \text{ th}}$		187	202	202											
20.044	538	1.38	M_2					103	80	191	152	143	260	212				
			c					5	5.3	2.8	3.1	3.2	2.1	2.1				
			$n_{2 \text{ Eck}}$					97	202	75	150	176	97	202				
			$n_{2 \text{ th}}$					97	202	75	150	176	97	193				
20.044	694	1.38	M_2												174			
			c													3.9		
			$n_{2 \text{ Eck}}$														75	
			$n_{2 \text{ th}}$														75	
22.778	475	1.35	M_2		65	81	96											
			c		5.8	4.6	3.9											
			$n_{2 \text{ Eck}}$		165	178	178											
			$n_{2 \text{ th}}$		165	178	178											

$M \dots$ [Nm]
 $n \dots$ [min^{-1}]
 $J \dots$ [kgcm^2]

$P \dots$ [kW]
 $I \dots$ [A]
 $i \dots$ [-]
 $c \dots$ [-]



$M_{2GN} \leq 706 \text{ Nm}$

14DC36	14HC15	14HC32	14LC15	14LC32	14PC14	14PC32	19FC14	19FC30	19JC14	19JC30	19PC14	19PC30	GST07-2S			
...S00	...S00	...S00	...S00	...S00	...S00	...S00	...S00	...S00	...S00	...S00	...S00	...S00	M_1	J_G	M_{2GN}	i
7.5	16	14	23	17.2	30	21	27	21	40	29	51	32	n_1			
3600	1500	3225	1500	3225	1350	3225	1425	3000	1425	3000	1350	3000	I_{M230}			
7.5	6.6	11.9	9.7	15	10.8	15.6	8.6	14	12.3	18.5	14.3	19	I_{M400}			
2.8	2.5	4.7	3.6	5.8	4.2	7.1	4	6.6	6	9.1	7.2	10	P_N			
8.22	14.32	14.32	23.44	23.44	34.74	34.82	65.12	65.04	105.04	105.12	160.12	160.04	J_M			
													M_2 c			
													$n_{2 \text{ Eck}}$	2.86	489	12.571
													$n_{2 \text{ th}}$			
88	191	168	277	207	363	254							M_2 c			
4.9	3.1	2.7	2.1	2.2	1.6	1.8							$n_{2 \text{ Eck}}$	2.86	601	12.571
286	119	257	119	257	107	257							$n_{2 \text{ th}}$			
273	119	243	119	233	107	216							M_2 c			
													$n_{2 \text{ Eck}}$	2.79	432	14.286
													$n_{2 \text{ th}}$			
													M_2 c			
													$n_{2 \text{ Eck}}$	2.79	556	14.286
													$n_{2 \text{ th}}$			
100	217	191	315	236	413	289							M_2 c			
4.6	2.9	2.6	2	2.1	1.5	1.7							$n_{2 \text{ Eck}}$	2.79	642	14.286
252	105	226	105	226	95	226							$n_{2 \text{ th}}$			
238	105	211	105	202	95	183							M_2 c			
													$n_{2 \text{ Eck}}$	2.26	515	15.4
													$n_{2 \text{ th}}$			
108	235	205	341	254	446	311							M_2 c			
4.9	2.7	2.7	1.9	2.2	1.4	1.8							$n_{2 \text{ Eck}}$	2.26	644	15.4
234	97	209	97	209	88	209							$n_{2 \text{ th}}$			
233	97	209	97	209	88	195							M_2 c			
													$n_{2 \text{ Eck}}$	2.21	585	17.5
													$n_{2 \text{ th}}$			
123	267	234	388	289	508	354							M_2 c			
4.5	2.5	2.5	1.7	2.1	1.3	1.7							$n_{2 \text{ Eck}}$	2.21	680	17.5
206	86	184	86	184	77	184							$n_{2 \text{ th}}$			
205	86	184	86	181	77	165							M_2 c			
													$n_{2 \text{ Eck}}$	1.38	418	20.044
													$n_{2 \text{ th}}$			
													M_2 c			
													$n_{2 \text{ Eck}}$	1.38	538	20.044
													$n_{2 \text{ th}}$			
141	307	269	445	332	582	406							M_2 c			
4	2.2	2.2	1.6	1.8	1.2	1.5							$n_{2 \text{ Eck}}$	1.38	694	20.044
180	75	161	75	161	67	161							$n_{2 \text{ th}}$			
179	75	161	75	161	67	161							M_2 c			
													$n_{2 \text{ Eck}}$	1.35	475	22.778
													$n_{2 \text{ th}}$			

M ... [Nm]
n ... [min⁻¹]
J ... [kgcm²]

P ... [kW]
I ... [A]
i [-]
c [-]

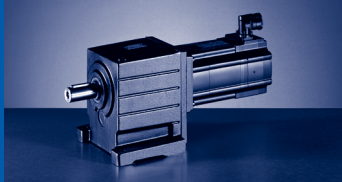

GST [Nm]

GST□□-□S (MCS)

$M_{2GN} \leq 706 \text{ Nm}$

GST07-2S				09DC41	09FC38	09HC41	09LC41	12DC20	12DC41	12HC15	12HC30	12HC35	12LC20	12LC41	14DC15	
				...500	...500	...500	...500	...500	...500	...500	...500	...500	...500	...500	...500	
i	M_{2GN}	J_G	M_1	2.3	3.1	3.8	4.5	5.5	4.3	10	8	7.5	13.5	11	9.2	
			n_1	4050	3750	4050	4050	1950	4050	1500	3000	3525	1950	4050	1500	
			I_{M230}	4.6	5	6.8	8.4	5.2	8.8	7.6	10.5		11.8			
			I_{M400}	2.3	2.5	3.4	4.2	2.6	4.5	3.8		5.7	5.9	10.2	4.5	
			P_N	1	1.2	1.6	1.9	1.1	1.8	1.6	2.5	2.8	2.8	4.7	1.45	
			J_M	1.13	1.53	1.93	2.83	4.12	4.12	7.42	7.42	7.42	10.72	10.72	8.22	
22.778	611	1.35	M_2					117	91	217	173	162	295	240		
			c				5	5.3	2.8	3.1	3.2	2.1	2.1			
			$n_{2 \text{ Eck}}$				86	178	66	132	155	86	178			
			$n_{2 \text{ th}}$				86	178	66	132	155	86	170			
22.778	682	1.35	M_2												198	
			c												3.4	
			$n_{2 \text{ Eck}}$													66
			$n_{2 \text{ th}}$													66
24.567	438	1.02	M_2		71	88	105									
			c		5	4	3.3									
			$n_{2 \text{ Eck}}$		153	165	165									
			$n_{2 \text{ th}}$		153	165	165									
24.567	564	1.02	M_2					127	99	235	187	176	319	260		
			c					4.3	4.5	2.4	2.7	2.7	1.8	1.8		
			$n_{2 \text{ Eck}}$					79	165	61	122	144	79	165		
			$n_{2 \text{ th}}$					79	165	61	122	143	79	165		
24.567	706	1.02	M_2												214	
			c												3.2	
			$n_{2 \text{ Eck}}$													61
			$n_{2 \text{ th}}$													61
27.917	498	1.01	M_2		81	100	119									
			c		5	4	3.3									
			$n_{2 \text{ Eck}}$		134	145	145									
			$n_{2 \text{ th}}$		134	145	145									
27.917	641	1.01	M_2					144	112	267	213	200	363	296		
			c					4.3	4.5	2.4	2.7	2.7	1.8	1.8		
			$n_{2 \text{ Eck}}$					70	145	54	108	126	70	145		
			$n_{2 \text{ th}}$					70	145	54	107	126	70	145		
27.917	691	1.01	M_2												245	
			c												2.8	
			$n_{2 \text{ Eck}}$													54
			$n_{2 \text{ th}}$													54
32.267	450	0.66	M_2	69	94	116	139									
			c	5.1	3.9	3.1	2.6									
			$n_{2 \text{ Eck}}$	126	116	126	126									
			$n_{2 \text{ th}}$	126	116	126	126									
32.267	580	0.66	M_2					168	131	310	248	232	421	343		
			c					3.4	3.5	1.9	2.1	2.1	1.4	1.4		
			$n_{2 \text{ Eck}}$					60	126	47	93	109	60	126		
			$n_{2 \text{ th}}$					60	126	46	93	109	60	126		
36.667	512	0.65	M_2	78	107	132	157									
			c	5.1	3.9	3.1	2.6									
			$n_{2 \text{ Eck}}$	111	102	111	111									
			$n_{2 \text{ th}}$	110	102	110	110									
36.667	659	0.65	M_2					191	149	353	281	264	478	390		
			c					3.4	3.5	1.9	2.1	2.1	1.4	1.4		
			$n_{2 \text{ Eck}}$					53	111	41	82	96	53	111		
			$n_{2 \text{ th}}$					53	110	41	82	96	53	110		
39.16	456	0.49	M_2	84	115	142	169									
			c	4.3	3.2	2.6	2.2									
			$n_{2 \text{ Eck}}$	103	96	103	103									
			$n_{2 \text{ th}}$	103	96	103	103									

$M \dots$ [Nm]
 $n \dots$ [min^{-1}]
 $J \dots$ [kgcm^2]

$P \dots$ [kW]
 $I \dots$ [A]
 $i \dots$ [-]
 $c \dots$ [-]

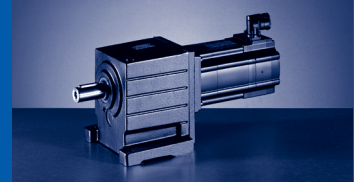

$M_{2GN} \leq 706 \text{ Nm}$

14DC36	14HC15	14HC32	14LC15	14LC32	14PC14	14PC32	19FC14	19FC30	19JC14	19JC30	19PC14	19PC30	GST07-2S			
...S00	...S00	...S00	...S00	...S00	...S00	...S00	...S00	...S00	...S00	...S00	...S00	...S00	M_1	J_G	M_{2GN}	i
7.5	16	14	23	17.2	30	21	27	21	40	29	51	32	n_1			
3600	1500	3225	1500	3225	1350	3225	1425	3000	1425	3000	1350	3000	I_{M230}			
7.5	6.6	11.9	9.7	15	10.8	15.6	8.6	14	12.3	18.5	14.3	19	I_{M400}			
2.8	2.5	4.7	3.6	5.8	4.2	7.1	4	6.6	6	9.1	7.2	10	P_N			
8.22	14.32	14.32	23.44	23.44	34.74	34.82	65.12	65.04	105.04	105.12	160.12	160.04	J_M			
													M_2 c	1.35	611	22.778
													n_2 Eck			
													n_2 th			
161	350	306	506	378	663	463							M_2 c	1.35	682	22.778
3.5	1.9	1.9	1.3	1.6	1	1.3							n_2 Eck			
158	66	142	66	142	59	142							n_2 th			
158	66	142	66	142	59	135							M_2 c	1.02	438	24.567
													n_2 Eck			
													n_2 th			
													M_2 c	1.02	564	24.567
													n_2 Eck			
													n_2 th			
174	378	331	547	408		499							M_2 c	1.02	706	24.567
3.4	1.9	1.9	1.3	1.5		1.2							n_2 Eck			
147	61	131	61	131		131							n_2 th			
146	61	131	61	131		131							M_2 c	1.01	498	27.917
													n_2 Eck			
													n_2 th			
													M_2 c	1.01	641	27.917
													n_2 Eck			
													n_2 th			
199	431	377	622	464		568							M_2 c	1.01	691	27.917
2.9	1.6	1.6	1.1	1.3		1.1							n_2 Eck			
129	54	116	54	116		116							n_2 th			
129	54	116	54	116		116							M_2 c	0.66	450	32.267
													n_2 Eck			
													n_2 th			
													M_2 c	0.66	580	32.267
													n_2 Eck			
													n_2 th			
													M_2 c	0.65	512	36.667
													n_2 Eck			
													n_2 th			
													M_2 c	0.65	659	36.667
													n_2 Eck			
													n_2 th			
													M_2 c	0.49	456	39.16
													n_2 Eck			
													n_2 th			

$M \dots$ [Nm]
 $n \dots$ [min^{-1}]
 $J \dots$ [kgcm^2]

$P \dots$ [kW]
 $I \dots$ [A]
 i [-]
 c [-]

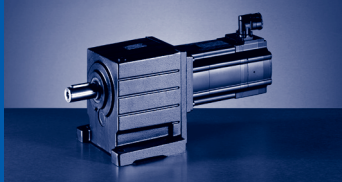

GST [Nm]

GST□□-□S (MCS)

$M_{2GN} \leq 706 \text{ Nm}$

GST07-2S				09DC41	09FC38	09HC41	09LC41	12DC20	12DC41	12HC15	12HC30	12HC35	12LC20	12LC41	14DC15
				...500	...500	...500	...500	...500	...500	...500	...500	...500	...500	...500	...500
i	M_{2GN}	J_G	M_1	2.3	3.1	3.8	4.5	5.5	4.3	10	8	7.5	13.5	11	9.2
			n_1	4050	3750	4050	4050	1950	4050	1500	3000	3525	1950	4050	1500
			I_{M230}	4.6	5	6.8	8.4	5.2	8.8	7.6	10.5		11.8		
			I_{M400}	2.3	2.5	3.4	4.2	2.6	4.5	3.8		5.7	5.9	10.2	4.5
			P_N	1	1.2	1.6	1.9	1.1	1.8	1.6	2.5	2.8	2.8	4.7	1.45
			J_M	1.13	1.53	1.93	2.83	4.12	4.12	7.42	7.42	7.42	10.72	10.72	8.22
39.16	586	0.49	M_2					205	160	378	302	283	512	417	
			c				2.8	2.9	1.5	1.7	1.8	1.1	1.2		
			$n_{2 \text{ Eck}}$				50	103	38	77	90	50	103		
			$n_{2 \text{ th}}$				50	103	38	77	90	50	103		
44.5	518	0.48	M_2	95	130	161	191								
			c	4.7	3.6	2.9	2.4								
			$n_{2 \text{ Eck}}$	91	84	91	91								
			$n_{2 \text{ th}}$	91	84	91	91								
44.5	666	0.48	M_2					233	181	429	342	321	582	474	
			c					2.8	3.3	1.5	1.9	2	1.1	1.3	
			$n_{2 \text{ Eck}}$					44	91	34	67	79	44	91	
			$n_{2 \text{ th}}$					44	91	34	67	79	44	91	
49.5	461	0.33	M_2	107	146	180	214								
			c	3.8	2.9	2.3	1.9								
			$n_{2 \text{ Eck}}$	82	76	82	82								
			$n_{2 \text{ th}}$	82	76	82	82								
56.25	524	0.33	M_2	122	166	205	243								
			c	3.8	2.9	2.3	1.9								
			$n_{2 \text{ Eck}}$	72	67	72	72								
			$n_{2 \text{ th}}$	72	67	72	72								

M ... [Nm]
 n ... [min^{-1}]
 J ... [kgcm^2]

P ... [kW]
 I ... [A]
 i [-]
 c [-]

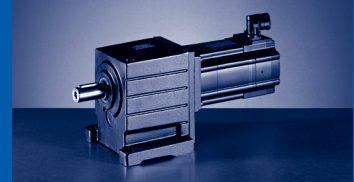

$M_{2GN} \leq 706 \text{ Nm}$

14DC36	14HC15	14HC32	14LC15	14LC32	14PC14	14PC32	19FC14	19FC30	19JC14	19JC30	19PC14	19PC30	GST07-2S			
...S00	...S00	...S00	...S00	...S00	...S00	...S00	...S00	...S00	...S00	...S00	...S00	...S00	M_1	J_G	M_{2GN}	i
7.5	16	14	23	17.2	30	21	27	21	40	29	51	32	n_1			
3600	1500	3225	1500	3225	1350	3225	1425	3000	1425	3000	1350	3000	I_{M230}			
7.5	6.6	11.9	9.7	15	10.8	15.6	8.6	14	12.3	18.5	14.3	19	I_{M400}			
2.8	2.5	4.7	3.6	5.8	4.2	7.1	4	6.6	6	9.1	7.2	10	P_N			
8.22	14.32	14.32	23.44	23.44	34.74	34.82	65.12	65.04	105.04	105.12	160.12	160.04	J_M			
													M_2			
													c	0.49	586	39.16
													$n_{2 \text{ Eck}}$			
													$n_{2 \text{ th}}$			
													M_2			
													c	0.48	518	44.5
													$n_{2 \text{ Eck}}$			
													$n_{2 \text{ th}}$			
													M_2			
													c	0.48	666	44.5
													$n_{2 \text{ Eck}}$			
													$n_{2 \text{ th}}$			
													M_2			
													c	0.33	461	49.5
													$n_{2 \text{ Eck}}$			
													$n_{2 \text{ th}}$			
													M_2			
													c	0.33	524	56.25
													$n_{2 \text{ Eck}}$			
													$n_{2 \text{ th}}$			

M ... [Nm]
n ... [min⁻¹]
J ... [kgcm²]

P ... [kW]
I ... [A]
i [-]
c [-]

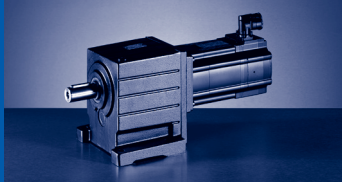

GST [Nm]

GST□□-□S (MCS)

$M_{2GN} \leq 710 \text{ Nm}$

GST07-3S				06CC41	06FC41	06IC41	09DC41	09FC38	09HC41	09LC41
				...500	...500	...500	...500	...500	...500	...500
i	M_{2GN}	J_G	M_1	0.6	1.2	1.5	2.3	3.1	3.8	4.5
			n_1	4050	4050	4050	4050	3750	4050	4050
			I_{M230}	2.6	2.9	3.2	4.6	5	6.8	8.4
			I_{M400}	1.3	1.5	1.6	2.3	2.5	3.4	4.2
			P_N	0.25	0.51	0.64	1	1.2	1.6	1.9
			J_M	0.17	0.25	0.33	1.13	1.53	1.93	2.83
39.2	692	0.97	M_2					111	138	164
			c				5	4	3.4	
			$n_{2 \text{ Eck}}$				96	103	103	
			$n_{2 \text{ th}}$				96	103	103	
44	706	0.53	M_2					125	155	185
			c				5	4	3.4	
			$n_{2 \text{ Eck}}$				85	92	92	
			$n_{2 \text{ th}}$				85	92	92	
51.022	700	0.84	M_2			107	146	181	215	
			c			5.7	4.3	3.4	2.9	
			$n_{2 \text{ Eck}}$			79	74	79	79	
			$n_{2 \text{ th}}$			79	74	79	79	
53.9	706	0.48	M_2			113	154	191	228	
			c			5.4	4.1	3.3	2.8	
			$n_{2 \text{ Eck}}$			75	70	75	75	
			$n_{2 \text{ th}}$			75	70	75	75	
65.079	587	0.31	M_2		89					
			c		5.7					
			$n_{2 \text{ Eck}}$		62					
			$n_{2 \text{ th}}$		62					
65.079	707	0.31	M_2			138	188	232	276	
			c			4.5	3.4	2.7	2.3	
			$n_{2 \text{ Eck}}$			62	58	62	62	
			$n_{2 \text{ th}}$			62	58	62	62	
70.156	706	0.43	M_2			149	203	251	298	
			c			4.1	3.2	2.5	2.1	
			$n_{2 \text{ Eck}}$			58	54	58	58	
			$n_{2 \text{ th}}$			58	53	58	58	
79.762	710	0.54	M_2		109	170	232	286	340	
			c		5.6	3.7	2.8	2.2	1.9	
			$n_{2 \text{ Eck}}$		51	51	47	51	51	
			$n_{2 \text{ th}}$		51	51	47	51	51	
85.983	706	0.4	M_2		118	184	251	309	367	
			c		5.2	3.4	2.6	2.1	1.7	
			$n_{2 \text{ Eck}}$		47	47	44	47	47	
			$n_{2 \text{ th}}$		47	47	44	47	47	
97.708	710	0.4	M_2	107	135	210	286	352	418	
			c	5.7	4.6	3	2.3	1.8	1.5	
			$n_{2 \text{ Eck}}$	42	42	42	38	42	42	
			$n_{2 \text{ th}}$	41	41	41	38	41	41	
111.915	706	0.24	M_2	123	155	242	328	404	480	
			c	5	4	2.6	2	1.6	1.3	
			$n_{2 \text{ Eck}}$	36	36	36	34	36	36	
			$n_{2 \text{ th}}$	36	36	36	34	36	36	
127.176	710	0.24	M_2	141	177	276	374	460	546	
			c	4.4	3.5	2.3	1.8	1.4	1.2	
			$n_{2 \text{ Eck}}$	32	32	32	30	32	32	
			$n_{2 \text{ th}}$	32	32	32	29	32	32	
139.211	706	0.17	M_2	155	195	303	410	504	598	
			c	4	3.2	2.1	1.6	1.3	1.1	
			$n_{2 \text{ Eck}}$	29	29	29	27	29	29	
			$n_{2 \text{ th}}$	29	29	29	27	29	29	

$M \dots [\text{Nm}]$
 $n \dots [\text{min}^{-1}]$
 $J \dots [\text{kgcm}^2]$

$P \dots [\text{kW}]$
 $I \dots [\text{A}]$
 $i \dots [-]$
 $c \dots [-]$

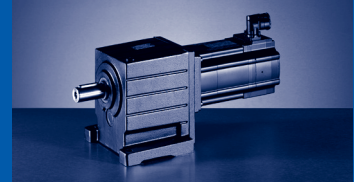

$M_{2GN} \leq 710 \text{ Nm}$

12DC20	12DC41	12HC15	12HC30	12HC35	12LC20	12LC41	GST07-3S			
...500	...500	...500	...500	...500	...500	...500				
5.5	4.3	10	8	7.5	13.5	11	M_1	J_G	M_{2GN}	i
1950	4050	1500	3000	3525	1950	4050	n_1			
5.2	8.8	7.6	10.5		11.8		I_{M230}			
2.6	4.5	3.8		5.7	5.9	10.2	I_{M400}			
1.1	1.8	1.6	2.5	2.8	2.8	4.7	P_N			
4.12	4.12	7.42	7.42	7.42	10.72	10.72	J_M			
201	157	371	296	278	504	410	M_2			
3.4	3.5	1.9	2.1	2.1	1.4	1.4	c	0.97	692	39.2
50	103	38	77	90	50	103	$n_{2\text{Eck}}$			
50	103	38	77	90	50	94	$n_{2\text{th}}$			
226	176	418	333	312	566	461	M_2			
3.1	3.5	1.7	2.1	2.1	1.2	1.4	c	0.53	706	44
44	92	34	68	80	44	92	$n_{2\text{Eck}}$			
44	92	34	68	80	44	92	$n_{2\text{th}}$			
264	205	485	387	363	658	535	M_2			
2.6	3	1.4	1.8	1.8	1.1	1.2	c	0.84	700	51.022
38	79	29	59	69	38	79	$n_{2\text{Eck}}$			
38	79	29	59	69	38	68	$n_{2\text{th}}$			
279	217	513	409	383	695	566	M_2			
2.5	2.9	1.4	1.7	1.7	1	1.1	c	0.48	706	53.9
36	75	28	56	65	36	75	$n_{2\text{Eck}}$			
36	75	28	56	65	36	75	$n_{2\text{th}}$			
							M_2			
							c	0.31	587	65.079
							$n_{2\text{Eck}}$			
							$n_{2\text{th}}$			
							M_2			
							c	0.31	707	65.079
							$n_{2\text{Eck}}$			
							$n_{2\text{th}}$			
365	285	670	535	501			M_2			
1.9	2.2	1.1	1.3	1.3			c	0.43	706	70.156
28	58	21	43	50			$n_{2\text{Eck}}$			
28	58	21	43	50			$n_{2\text{th}}$			
416	324		609	571			M_2			
1.7	2		1.2	1.2			c	0.54	710	79.762
25	51		38	44			$n_{2\text{Eck}}$			
24	51		38	44			$n_{2\text{th}}$			
449	350		657	616			M_2			
1.6	1.8		1.1	1.1			c	0.4	706	85.983
23	47		35	41			$n_{2\text{Eck}}$			
23	47		35	41			$n_{2\text{th}}$			
512	399						M_2			
1.4	1.6						c	0.4	710	97.708
20	42						$n_{2\text{Eck}}$			
20	41						$n_{2\text{th}}$			
							M_2			
							c	0.24	706	111.915
							$n_{2\text{Eck}}$			
							$n_{2\text{th}}$			
							M_2			
							c	0.24	710	127.176
							$n_{2\text{Eck}}$			
							$n_{2\text{th}}$			
							M_2			
							c	0.17	706	139.211
							$n_{2\text{Eck}}$			
							$n_{2\text{th}}$			

M ... [Nm]
n ... [min⁻¹]
J ... [kgcm²]

P ... [kW]
I ... [A]
i [-]
c [-]

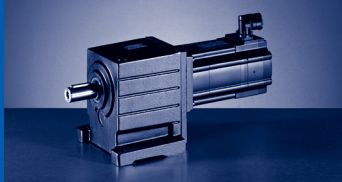

GST [Nm]

GST□□-□S (MCS)

$M_{2GN} \leq 710 \text{ Nm}$

GST07-3S				06CC41	06FC41	06IC41	09DC41	09FC38	09HC41	09LC41
				...500	...500	...500	...500	...500	...500	...500
i	M_{2GN}	J_G	M_1							
			n_1	4050	4050	4050	4050	3750	4050	4050
			I_{M230}	2.6	2.9	3.2	4.6	5	6.8	8.4
			I_{M400}	1.3	1.5	1.6	2.3	2.5	3.4	4.2
			P_N	0.25	0.51	0.64	1	1.2	1.6	1.9
			J_M	0.17	0.25	0.33	1.13	1.53	1.93	2.83
158.194	710	0.17	M_2		177	222	345	467	574	
			c		3.5	2.8	1.9	1.4	1.1	
			n_2 Eck		26	26	26	24	26	
			n_2 th		26	26	26	24	26	
180.156	706	0.11	M_2		202	254				
			c		3.1	2.5				
			n_2 Eck		23	23				
			n_2 th		22	22				
204.722	710	0.11	M_2	112	231	290				
			c	5.5	2.7	2.2				
			n_2 Eck	20	20	20				
			n_2 th	20	20	20				
236.622	706	0.1	M_2	130	268	336				
			c	4.7	2.4	1.9				
			n_2 Eck	17	17	17				
			n_2 th	17	17	17				
248.458	710	0.08	M_2	137	281	353				
			c	4.5	2.3	1.8				
			n_2 Eck	16	16	16				
			n_2 th	16	16	16				
268.889	710	0.1	M_2	149	305	383				
			c	4.2	2.1	1.7				
			n_2 Eck	15	15	15				
			n_2 th	15	15	15				
326.333	710	0.07	M_2	182	371	466				
			c	3.4	1.7	1.4				
			n_2 Eck	12	12	12				
			n_2 th	12	12	12				

$M \dots$ [Nm]
 $n \dots$ [min^{-1}]
 $J \dots$ [kgcm^2]

$P \dots$ [kW]
 $I \dots$ [A]
 i [-]
 c [-]



$M_{2GN} \leq 710 \text{ Nm}$

12DC20	12DC41	12HC15	12HC30	12HC35	12LC20	12LC41	GST07-3S			
...500	...500	...500	...500	...500	...500	...500	M_1	J_G	M_{2GN}	i
5.5	4.3	10	8	7.5	13.5	11	n_1			
1950	4050	1500	3000	3525	1950	4050	I_{M230}			
5.2	8.8	7.6	10.5		11.8		I_{M400}			
2.6	4.5	3.8		5.7	5.9	10.2	P_N			
1.1	1.8	1.6	2.5	2.8	2.8	4.7	J_M			
4.12	4.12	7.42	7.42	7.42	10.72	10.72	M_2 c n_2 Eck n_2 th	0.17	710	158.194
							M_2 c n_2 Eck n_2 th	0.11	706	180.156
							M_2 c n_2 Eck n_2 th	0.11	710	204.722
							M_2 c n_2 Eck n_2 th	0.1	706	236.622
							M_2 c n_2 Eck n_2 th	0.08	710	248.458
							M_2 c n_2 Eck n_2 th	0.1	710	268.889
							M_2 c n_2 Eck n_2 th	0.07	710	326.333

M ... [Nm]
n ... [min⁻¹]
J ... [kgcm²]

P ... [kW]
I ... [A]
i [-]
c [-]

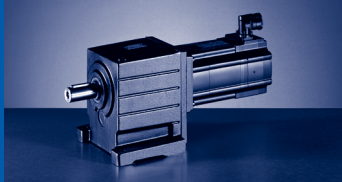

GST [Nm]

GST□□-□S (MCS)

$M_{2GN} \leq 357 \text{ Nm}$

GST09-1S				12DC20	12DC41	12HC15	12HC30	12HC35	12LC20	12LC41	14DC15	14DC36	14HC15
				...500	...500	...500	...500	...500	...500	...500	...500	...500	...500
i	M_{2GN}	J_G	M_1	5.5	4.3	10	8	7.5	13.5	11	9.2	7.5	16
			n_1	1950	4050	1500	3000	3525	1950	4050	1500	3600	1500
			I_{M230}	5.2	8.8	7.6	10.5		11.8				
			I_{M400}	2.6	4.5	3.8		5.7	5.9	10.2	4.5	7.5	6.6
			P_N	1.1	1.8	1.6	2.5	2.8	2.8	4.7	1.45	2.8	2.5
			J_M	4.12	4.12	7.42	7.42	7.42	10.72	10.72	8.22	8.22	14.32
1.56	277	22.2	M_2 c $n_{2 \text{ Eck}}$ $n_{2 \text{ th}}$										
2.048	198	15.6	M_2 c $n_{2 \text{ Eck}}$ $n_{2 \text{ th}}$										
2.048	308	15.6	M_2 c $n_{2 \text{ Eck}}$ $n_{2 \text{ th}}$										
2.333	207	12.2	M_2 c $n_{2 \text{ Eck}}$ $n_{2 \text{ th}}$										35 5.6 643 643
2.333	322	12.2	M_2 c $n_{2 \text{ Eck}}$ $n_{2 \text{ th}}$										
2.81	140	9.58	M_2 c $n_{2 \text{ Eck}}$ $n_{2 \text{ th}}$			27 5 534 534	21 5 1068 1012	20 5.1 1255 1014	36 3.4 694 694	30 3.3 1442 927			
2.81	218	9.58	M_2 c $n_{2 \text{ Eck}}$ $n_{2 \text{ th}}$										43 4.9 534 534
2.81	339	9.58	M_2 c $n_{2 \text{ Eck}}$ $n_{2 \text{ th}}$										
3.444	230	7.3	M_2 c $n_{2 \text{ Eck}}$ $n_{2 \text{ th}}$										53 4.2 436 435
3.444	357	7.3	M_2 c $n_{2 \text{ Eck}}$ $n_{2 \text{ th}}$										
4.667	156	4.6	M_2 c $n_{2 \text{ Eck}}$ $n_{2 \text{ th}}$	24 5.7 418 418	19 5.7 868 814	45 3.4 321 321	36 3.4 643 643	34 3.4 755 744	61 2.3 418 418	50 2.2 868 685			
4.667	243	4.6	M_2 c $n_{2 \text{ Eck}}$ $n_{2 \text{ th}}$								40 5.8 321 321	33 5.3 771 769	72 3.3 321 321
5.667	162	3.51	M_2 c $n_{2 \text{ Eck}}$ $n_{2 \text{ th}}$	30 4.8 344 344	23 4.9 715 715	55 2.9 265 265	44 2.9 529 529	41 2.9 622 622	75 2 344 344	61 1.9 715 641			

$M \dots [\text{Nm}]$
 $n \dots [\text{min}^{-1}]$
 $J \dots [\text{kgcm}^2]$

$P \dots [\text{kW}]$
 $I \dots [\text{A}]$
 $i \dots [-]$
 $c \dots [-]$

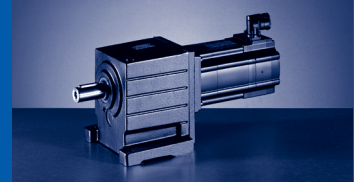

$M_{2GN} \leq 357 \text{ Nm}$

14HC32	14LC15	14LC32	14PC14	14PC32	19FC14	19FC30	19JC14	19JC30	19PC14	19PC30	GST09-1S			
...S00	...S00	...S00	...S00	...S00	...S00	...S00	...S00	...S00	...S00	...S00	M_1	J_G	M_{2GN}	i
14	23	17.2	30	21	27	21	40	29	51	32	n_1			
3225	1500	3225	1350	3225	1425	3000	1425	3000	1350	3000	I_{M230}			
											I_{M400}			
11.9	9.7	15	10.8	15.6	8.6	14	12.3	18.5	14.3	19	P_N			
4.7	3.6	5.8	4.2	7.1	4	6.6	6	9.1	7.2	10	J_M			
14.32	23.44	23.44	34.74	34.82	65.12	65.04	105.04	105.12	160.12	160.04	M_2			
							59	43	76	47	c	22.2	277	1.56
							4.5	4.9	3.5	4.5	$n_{2 \text{ Eck}}$			
							914	1923	865	1923	$n_{2 \text{ th}}$			
							913	1294	865	1267				
27	45	33	59	41							M_2			
5.4	4.3	4.4	3.3	3.6							c	15.6	198	2.048
1575	733	1575	659	1575							$n_{2 \text{ Eck}}$			
1142	733	1094	659	1048							$n_{2 \text{ th}}$			
					52	40	78	57	101	63	M_2			
					5.7	5.8	3.8	4.2	3	3.8	c	15.6	308	2.048
					696	1465	696	1465	659	1465	$n_{2 \text{ Eck}}$			
					696	1080	696	1080	659	1058	$n_{2 \text{ th}}$			
31	51	38	68	47							M_2			
5	3.9	4.1	3	3.3							c	12.2	207	2.333
1382	643	1382	579	1382							$n_{2 \text{ Eck}}$			
1077	643	1032	579	988							$n_{2 \text{ th}}$			
					59	46	90	65	115	72	M_2			
					5.2	5.3	3.5	3.8	2.7	3.5	c	12.2	322	2.333
					611	1286	611	1286	579	1286	$n_{2 \text{ Eck}}$			
					611	947	611	947	579	947	$n_{2 \text{ th}}$			
											M_2			
											c	9.58	140	2.81
											$n_{2 \text{ Eck}}$			
											$n_{2 \text{ th}}$			
37	62	46	82	57							M_2			
4.4	3.4	3.6	2.6	2.9							c	9.58	218	2.81
1148	534	1148	481	1148							$n_{2 \text{ Eck}}$			
984	534	943	481	902							$n_{2 \text{ th}}$			
					72	56	108	78	139	87	M_2			
					4.5	4.6	3.1	3.4	2.4	3	c	9.58	339	2.81
					507	1068	507	1068	481	1068	$n_{2 \text{ Eck}}$			
					507	787	507	787	481	787	$n_{2 \text{ th}}$			
46	76	57	100	70							M_2			
3.8	3	3.1	2.3	2.5							c	7.3	230	3.444
936	436	936	392	936							$n_{2 \text{ Eck}}$			
845	435	811	392	778							$n_{2 \text{ th}}$			
					89	69	133	97	171	107	M_2			
					3.9	4	2.6	2.9	2.1	2.6	c	7.3	357	3.444
					414	871	414	871	392	871	$n_{2 \text{ Eck}}$			
					414	642	414	642	392	642	$n_{2 \text{ th}}$			
											M_2			
											c	4.6	156	4.667
											$n_{2 \text{ Eck}}$			
											$n_{2 \text{ th}}$			
63	104	78	137	96							M_2			
2.9	2.3	2.4	1.8	2							c	4.6	243	4.667
691	321	691	289	691							$n_{2 \text{ Eck}}$			
691	321	691	289	666							$n_{2 \text{ th}}$			
											M_2			
											c	3.51	162	5.667
											$n_{2 \text{ Eck}}$			
											$n_{2 \text{ th}}$			

$M \dots$ [Nm]
 $n \dots$ [min^{-1}]
 $J \dots$ [kgcm^2]

$P \dots$ [kW]
 $I \dots$ [A]
 $i [-]$
 $c [-]$

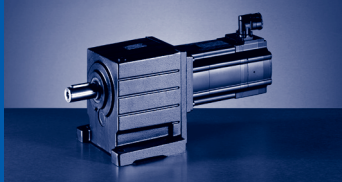

GST [Nm]

GST□□-□S (MCS)

$M_{2GN} \leq 357 \text{ Nm}$

GST09-1S				12DC20	12DC41	12HC15	12HC30	12HC35	12LC20	12LC41	14DC15	14DC36	14HC15
				...500	...500	...500	...500	...500	...500	...500	...500	...500	...500
i	M_{2GN}	J_G	M_1	5.5	4.3	10	8	7.5	13.5	11	9.2	7.5	16
			n_1	1950	4050	1500	3000	3525	1950	4050	1500	3600	1500
			I_{M230}	5.2	8.8	7.6	10.5		11.8				
			I_{M400}	2.6	4.5	3.8		5.7	5.9	10.2	4.5	7.5	6.6
			P_N	1.1	1.8	1.6	2.5	2.8	2.8	4.7	1.45	2.8	2.5
			J_M	4.12	4.12	7.42	7.42	7.42	10.72	10.72	8.22	8.22	14.32
5.667	253	3.51	M_2								49	40	88
			c								4.9	4.5	2.8
			$n_{2 \text{ Eck}}$								265	635	265
			$n_{2 \text{ th}}$								265	634	265
7.333	168	2.26	M_2	39	30	71	57	53	97	79			
			c	3.9	3.9	2.3	2.3	2.3	1.6	1.5			
			$n_{2 \text{ Eck}}$	266	552	205	409	481	266	552			
			$n_{2 \text{ th}}$	266	552	205	409	481	266	514			
7.333	262	2.26	M_2								64	53	114
			c								4	3.6	2.3
			$n_{2 \text{ Eck}}$								205	491	205
			$n_{2 \text{ th}}$								205	490	205
8.9	170	1.66	M_2	47	37	87	69	65	118	96			
			c	3.2	3.3	1.9	1.9	2	1.3	1.3			
			$n_{2 \text{ Eck}}$	219	455	169	337	396	219	455			
			$n_{2 \text{ th}}$	219	455	169	337	396	219	450			
8.9	265	1.66	M_2								79	64	139
			c								3.3	3	1.9
			$n_{2 \text{ Eck}}$								169	405	169
			$n_{2 \text{ th}}$								169	403	169
11.25	173	1.11	M_2	60	47	110	88	83	150	122			
			c	2.6	2.6	1.6	1.6	1.6	1.1	1			
			$n_{2 \text{ Eck}}$	173	360	133	267	313	173	360			
			$n_{2 \text{ th}}$	173	360	133	267	313	173	360			

$M \dots [\text{Nm}]$
 $n \dots [\text{min}^{-1}]$
 $J \dots [\text{kgcm}^2]$

$P \dots [\text{kW}]$
 $I \dots [\text{A}]$
 $i \dots [-]$
 $c \dots [-]$

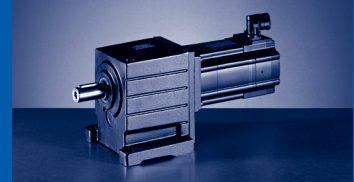

$M_{2GN} \leq 357 \text{ Nm}$

14HC32	14LC15	14LC32	14PC14	14PC32	19FC14	19FC30	19JC14	19JC30	19PC14	19PC30	GST09-1S			
...S00	...S00	...S00	...S00	...S00	...S00	...S00	...S00	...S00	...S00	...S00	M_1	J_G	M_{2GN}	i
14	23	17.2	30	21	27	21	40	29	51	32	n_1			
3225	1500	3225	1350	3225	1425	3000	1425	3000	1350	3000	I_{M230}			
11.9	9.7	15	10.8	15.6	8.6	14	12.3	18.5	14.3	19	I_{M400}			
4.7	3.6	5.8	4.2	7.1	4	6.6	6	9.1	7.2	10	P_N			
14.32	23.44	23.44	34.74	34.82	65.12	65.04	105.04	105.12	160.12	160.04	J_M			
77	127	95	167	116							M_2			
2.5	2	2	1.5	1.7							c			
569	265	569	238	569							$n_{2 \text{ Eck}}$	3.51	253	5.667
569	265	569	238	569							$n_{2 \text{ th}}$			
											M_2			
											c			
											$n_{2 \text{ Eck}}$	2.26	168	7.333
											$n_{2 \text{ th}}$			
100	165	123	216	151							M_2			
2	1.6	1.6	1.2	1.3							c			
440	205	440	184	440							$n_{2 \text{ Eck}}$	2.26	262	7.333
440	205	440	184	440							$n_{2 \text{ th}}$			
											M_2			
											c			
											$n_{2 \text{ Eck}}$	1.66	170	8.9
											$n_{2 \text{ th}}$			
122	201	150	263	184							M_2			
1.7	1.3	1.4	1	1.1							c			
362	169	362	152	362							$n_{2 \text{ Eck}}$	1.66	265	8.9
362	169	362	152	362							$n_{2 \text{ th}}$			
											M_2			
											c			
											$n_{2 \text{ Eck}}$	1.11	173	11.25
											$n_{2 \text{ th}}$			

M ... [Nm]
n ... [min⁻¹]
J ... [kgcm²]

P ... [kW]
I ... [A]
i [-]
c [-]

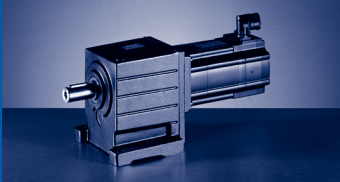

GST [Nm]

GST□□-□S (MCS)

$M_{2GN} \leq 1373 \text{ Nm}$

GST09-2S				12DC20	12DC41	12HC15	12HC30	12HC35	12LC20	12LC41	14DC15	14DC36	14HC15
				...500	...500	...500	...500	...500	...500	...500	...500	...500	...500
i	M_{2GN}	J_G	M_1	5.5	4.3	10	8	7.5	13.5	11	9.2	7.5	16
			n_1	1950	4050	1500	3000	3525	1950	4050	1500	3600	1500
			I_{M230}	5.2	8.8	7.6	10.5		11.8				
			I_{M400}	2.6	4.5	3.8		5.7	5.9	10.2	4.5	7.5	6.6
			P_N	1.1	1.8	1.6	2.5	2.8	2.8	4.7	1.45	2.8	2.5
			J_M	4.12	4.12	7.42	7.42	7.42	10.72	10.72	8.22	8.22	14.32
4.056	714	27	M_2 c $n_{2 \text{ Eck}}$ $n_{2 \text{ th}}$										
4.457	784	25.9	M_2 c $n_{2 \text{ Eck}}$ $n_{2 \text{ th}}$										
5.324	508	18.1	M_2 c $n_{2 \text{ Eck}}$ $n_{2 \text{ th}}$										
5.324	789	18.1	M_2 c $n_{2 \text{ Eck}}$ $n_{2 \text{ th}}$										
5.85	558	17.5	M_2 c $n_{2 \text{ Eck}}$ $n_{2 \text{ th}}$										
5.85	867	17.5	M_2 c $n_{2 \text{ Eck}}$ $n_{2 \text{ th}}$										
6.667	583	14.2	M_2 c $n_{2 \text{ Eck}}$ $n_{2 \text{ th}}$										99 5.6 225 225
6.667	905	14.2	M_2 c $n_{2 \text{ Eck}}$ $n_{2 \text{ th}}$										
7.305	357	11.3	M_2 c $n_{2 \text{ Eck}}$ $n_{2 \text{ th}}$			68 5 205 205	54 5 411 389	51 5.1 483 390	93 3.4 267 267	76 3.3 554 357			
7.305	559	11.3	M_2 c $n_{2 \text{ Eck}}$ $n_{2 \text{ th}}$										109 4.9 205 205
7.305	869	11.3	M_2 c $n_{2 \text{ Eck}}$ $n_{2 \text{ th}}$										
8.027	393	11	M_2 c $n_{2 \text{ Eck}}$ $n_{2 \text{ th}}$			75 5 187 187	60 5 374 354	56 5.1 439 355	103 3.4 243 243	84 3.3 505 324			
8.027	615	11	M_2 c $n_{2 \text{ Eck}}$ $n_{2 \text{ th}}$										120 4.9 187 187

$M \dots$ [Nm]
 $n \dots$ [min^{-1}]
 $J \dots$ [kgcm^2]

$P \dots$ [kW]
 $I \dots$ [A]
 $i \dots$ [-]
 $c \dots$ [-]

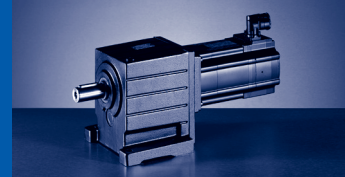

$M_{2GN} \leq 1373 \text{ Nm}$

14HC32	14LC15	14LC32	14PC14	14PC32	19FC14	19FC30	19JC14	19JC30	19PC14	19PC30	GST09-2S			
...S00	...S00	...S00	...S00	...S00	...S00	...S00	...S00	...S00	...S00	...S00	M_1	J_G	M_{2GN}	i
14	23	17.2	30	21	27	21	40	29	51	32	n_1			
3225	1500	3225	1350	3225	1425	3000	1425	3000	1350	3000	I_{M230}			
											I_{M400}			
11.9	9.7	15	10.8	15.6	8.6	14	12.3	18.5	14.3	19	P_N			
4.7	3.6	5.8	4.2	7.1	4	6.6	6	9.1	7.2	10	J_M			
14.32	23.44	23.44	34.74	34.82	65.12	65.04	105.04	105.12	160.12	160.04	M_2			
							152	109	195	121	c			
							4.5	5	3.6	4.5	$n_2 \text{ Eck}$	27	714	4.056
							351	740	333	740	$n_2 \text{ th}$			
							351	498	333	488	M_2			
							167	120	215	133	c			
							4.5	5	3.6	4.5	$n_2 \text{ Eck}$	25.9	784	4.457
							320	673	303	673	$n_2 \text{ th}$			
							320	454	303	444	M_2			
69	115	86	151	106							c			
5.4	4.3	4.4	3.3	3.6							$n_2 \text{ Eck}$	18.1	508	5.324
606	282	606	254	606							$n_2 \text{ th}$			
439	282	421	254	403							M_2			
					133	103	201	145	258	161	c			
					5.7	5.8	3.8	4.2	3	3.8	$n_2 \text{ Eck}$	18.1	789	5.324
					268	564	268	564	254	564	$n_2 \text{ th}$			
					268	415	268	415	254	407	M_2			
76	126	94	166	116							c			
5.4	4.3	4.4	3.3	3.6							$n_2 \text{ Eck}$	17.5	558	5.85
551	256	551	231	551							$n_2 \text{ th}$			
400	256	383	231	367							M_2			
					146	113	220	159	284	176	c			
					5.7	5.8	3.8	4.2	3	3.8	$n_2 \text{ Eck}$	17.5	867	5.85
					244	513	244	513	231	513	$n_2 \text{ th}$			
					244	378	244	378	231	370	M_2			
87	144	108	190	133							c			
5	3.9	4.1	3	3.3							$n_2 \text{ Eck}$	14.2	583	6.667
484	225	484	203	484							$n_2 \text{ th}$			
377	225	361	203	346							M_2			
					167	130	252	182	324	202	c			
					5.2	5.3	3.5	3.8	2.7	3.5	$n_2 \text{ Eck}$	14.2	905	6.667
					214	450	214	450	203	450	$n_2 \text{ th}$			
					214	332	214	332	203	332	M_2			
											c			
											$n_2 \text{ Eck}$	11.3	357	7.305
											$n_2 \text{ th}$			
96	159	119	209	146							M_2			
4.4	3.4	3.6	2.6	2.9							c			
442	205	442	185	442							$n_2 \text{ Eck}$	11.3	559	7.305
379	205	363	185	347							$n_2 \text{ th}$			
					184	143	277	201	356	222	M_2			
					4.5	4.6	3.1	3.4	2.4	3	c			
					195	411	195	411	185	411	$n_2 \text{ Eck}$	11.3	869	7.305
					195	303	195	303	185	303	$n_2 \text{ th}$			
											M_2			
											c			
											$n_2 \text{ Eck}$	11	393	8.027
											$n_2 \text{ th}$			
105	175	130	230	160							M_2			
4.4	3.4	3.6	2.6	2.9							c			
402	187	402	168	402							$n_2 \text{ Eck}$	11	615	8.027
345	187	330	168	316							$n_2 \text{ th}$			

M ... [Nm]
n ... [min⁻¹]
J ... [kgcm²]

P ... [kW]
I ... [A]
i [-]
c [-]

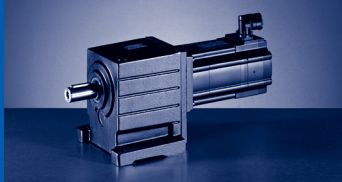

GST [Nm]

GST□□-□S (MCS)

$M_{2GN} \leq 1373 \text{ Nm}$

GST09-2S				12DC20	12DC41	12HC15	12HC30	12HC35	12LC20	12LC41	14DC15	14DC36	14HC15
				...500	...500	...500	...500	...500	...500	...500	...500	...500	...500
i	M_{2GN}	J_G	M_1	5.5	4.3	10	8	7.5	13.5	11	9.2	7.5	16
			n_1	1950	4050	1500	3000	3525	1950	4050	1500	3600	1500
			I_{M230}	5.2	8.8	7.6	10.5		11.8				
			I_{M400}	2.6	4.5	3.8		5.7	5.9	10.2	4.5	7.5	6.6
			P_N	1.1	1.8	1.6	2.5	2.8	2.8	4.7	1.45	2.8	2.5
			J_M	4.12	4.12	7.42	7.42	7.42	10.72	10.72	8.22	8.22	14.32
8.027	955	11	M_2 c $n_{2 \text{ Eck}}$ $n_{2 \text{ th}}$										
9.01	860	15.2	M_2 c $n_{2 \text{ Eck}}$ $n_{2 \text{ th}}$										
9.01	1128	15.2	M_2 c $n_{2 \text{ Eck}}$ $n_{2 \text{ th}}$										
10.267	897	12.4	M_2 c $n_{2 \text{ Eck}}$ $n_{2 \text{ th}}$										152 5.6 146 146
10.267	1178	12.4	M_2 c $n_{2 \text{ Eck}}$ $n_{2 \text{ th}}$										
11.667	1019	12.1	M_2 c $n_{2 \text{ Eck}}$ $n_{2 \text{ th}}$										172 5.6 129 129
11.667	1206	12.1	M_2 c $n_{2 \text{ Eck}}$ $n_{2 \text{ th}}$										
12.362	605	9.79	M_2 c $n_{2 \text{ Eck}}$ $n_{2 \text{ th}}$			115 5 121 121	92 5 243 230	86 5.1 285 230	158 3.4 158 158	129 3.3 328 211			
12.362	947	9.79	M_2 c $n_{2 \text{ Eck}}$ $n_{2 \text{ th}}$										184 4.9 121 121
12.362	1253	9.79	M_2 c $n_{2 \text{ Eck}}$ $n_{2 \text{ th}}$										
14.048	687	9.53	M_2 c $n_{2 \text{ Eck}}$ $n_{2 \text{ th}}$			131 5 107 107	105 5 214 202	98 5.1 251 203	179 3.4 139 139	146 3.3 288 185			
14.048	1076	9.53	M_2 c $n_{2 \text{ Eck}}$ $n_{2 \text{ th}}$										209 4.9 107 107
14.048	1283	9.53	M_2 c $n_{2 \text{ Eck}}$ $n_{2 \text{ th}}$										

$M \dots$ [Nm]
 $n \dots$ [min^{-1}]
 $J \dots$ [kgcm^2]

$P \dots$ [kW]
 $I \dots$ [A]
 $i \dots$ [-]
 $c \dots$ [-]



$M_{2GN} \leq 1373 \text{ Nm}$

14HC32	14LC15	14LC32	14PC14	14PC32	19FC14	19FC30	19JC14	19JC30	19PC14	19PC30	GST09-2S			
...S00	...S00	...S00	...S00	...S00	...S00	...S00	...S00	...S00	...S00	...S00	M_1	J_G	M_{2GN}	i
14	23	17.2	30	21	27	21	40	29	51	32	n_1			
3225	1500	3225	1350	3225	1425	3000	1425	3000	1350	3000	I_{M230}			
11.9	9.7	15	10.8	15.6	8.6	14	12.3	18.5	14.3	19	I_{M400}			
4.7	3.6	5.8	4.2	7.1	4	6.6	6	9.1	7.2	10	P_N			
14.32	23.44	23.44	34.74	34.82	65.12	65.04	105.04	105.12	160.12	160.04	J_M			
					203	157	305	220	391	244	M_2			
					4.5	4.6	3.1	3.4	2.4	3	c	11	955	8.027
					178	374	178	374	168	374	$n_2 \text{ Eck}$			
					178	275	178	275	168	275	$n_2 \text{ th}$			
117	194	145	256	179							M_2			
5.4	4.3	4.4	3.3	3.6							c	15.2	860	9.01
358	167	358	150	358							$n_2 \text{ Eck}$			
259	166	249	150	238							$n_2 \text{ th}$			
					227	176	342	247	439	273	M_2			
					4.8	4.9	3.2	3.5	2.5	3.2	c	15.2	1128	9.01
					158	333	158	333	150	333	$n_2 \text{ Eck}$			
					158	245	158	237	150	232	$n_2 \text{ th}$			
134	222	166	293	204							M_2			
5	3.9	4.1	3	3.3							c	12.4	897	10.267
314	146	314	132	314							$n_2 \text{ Eck}$			
245	146	235	131	225							$n_2 \text{ th}$			
					260	202	390	282	501	312	M_2			
					4.4	4.5	3	3.2	2.3	2.9	c	12.4	1178	10.267
					139	292	139	292	132	292	$n_2 \text{ Eck}$			
					139	215	139	215	131	215	$n_2 \text{ th}$			
152	253	189	333	232							M_2			
5	3.9	4.1	3	3.3							c	12.1	1019	11.667
276	129	276	116	276							$n_2 \text{ Eck}$			
215	129	206	116	198							$n_2 \text{ th}$			
					296	230	445	322	571	356	M_2			
					4	4	2.7	2.9	2.1	2.6	c	12.1	1206	11.667
					122	257	122	257	116	257	$n_2 \text{ Eck}$			
					122	189	122	189	116	188	$n_2 \text{ th}$			
											M_2			
											c	9.79	605	12.362
											$n_2 \text{ Eck}$			
											$n_2 \text{ th}$			
162	269	201	354	247							M_2			
4.4	3.4	3.6	2.6	2.9							c	9.79	947	12.362
261	121	261	109	261							$n_2 \text{ Eck}$			
224	121	214	109	205							$n_2 \text{ th}$			
					314	244	472	341	605	378	M_2			
					3.9	4	2.6	2.9	2.1	2.6	c	9.79	1253	12.362
					115	243	115	243	109	243	$n_2 \text{ Eck}$			
					115	179	115	179	109	179	$n_2 \text{ th}$			
											M_2			
											c	9.53	687	14.048
											$n_2 \text{ Eck}$			
											$n_2 \text{ th}$			
184	306	228	402	281							M_2			
4.4	3.4	3.6	2.6	2.9							c	9.53	1076	14.048
230	107	230	96	230							$n_2 \text{ Eck}$			
197	107	189	96	180							$n_2 \text{ th}$			
					359	279	538	389	689	430	M_2			
					3.5	3.6	2.4	2.6	1.9	2.3	c	9.53	1283	14.048
					101	214	101	214	96	214	$n_2 \text{ Eck}$			
					101	157	101	157	96	157	$n_2 \text{ th}$			

$M \dots$ [Nm]
 $n \dots$ [min^{-1}]
 $J \dots$ [kgcm^2]

$P \dots$ [kW]
 $I \dots$ [A]
 $i [-]$
 $c [-]$

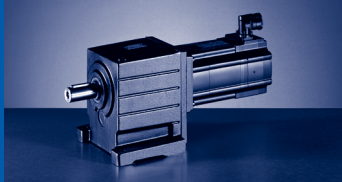

GST [Nm]

GST□□-□S (MCS)

$M_{2GN} \leq 1373 \text{ Nm}$

GST09-2S				12DC20	12DC41	12HC15	12HC30	12HC35	12LC20	12LC41	14DC15	14DC36	14HC15
				...500	...500	...500	...500	...500	...500	...500	...500	...500	...500
i	M_{2GN}	J_G	M_1	5.5	4.3	10	8	7.5	13.5	11	9.2	7.5	16
			n_1	1950	4050	1500	3000	3525	1950	4050	1500	3600	1500
			I_{M230}	5.2	8.8	7.6	10.5		11.8				
			I_{M400}	2.6	4.5	3.8		5.7	5.9	10.2	4.5	7.5	6.6
			P_N	1.1	1.8	1.6	2.5	2.8	2.8	4.7	1.45	2.8	2.5
			J_M	4.12	4.12	7.42	7.42	7.42	10.72	10.72	8.22	8.22	14.32
15.156	996	7.65	M_2										227
			c										4.2
			$n_{2 \text{ Eck}}$										99
			$n_{2 \text{ th}}$										99
15.156	1340	7.65	M_2										
			c										
			$n_{2 \text{ Eck}}$										
			$n_{2 \text{ th}}$										
17.222	1132	7.49	M_2										258
			c										4.2
			$n_{2 \text{ Eck}}$										87
			$n_{2 \text{ th}}$										87
17.222	1373	7.49	M_2										
			c										
			$n_{2 \text{ Eck}}$										
			$n_{2 \text{ th}}$										
20.533	675	4.5	M_2			194	155	145	265	216			
			c			3.4	3.8	3.9	2.5	2.5			
			$n_{2 \text{ Eck}}$			73	146	172	95	197			
			$n_{2 \text{ th}}$			73	146	172	95	160			
20.533	1055	4.5	M_2								174	142	311
			c								5.8	6	3.3
			$n_{2 \text{ Eck}}$								73	175	73
			$n_{2 \text{ th}}$								73	175	73
23.333	767	4.41	M_2			221	176	165	301	245			
			c			3.4	3.8	3.9	2.5	2.5			
			$n_{2 \text{ Eck}}$			64	129	151	84	174			
			$n_{2 \text{ th}}$			64	129	151	84	140			
23.333	1199	4.41	M_2								198	161	354
			c								5.8	6	3.3
			$n_{2 \text{ Eck}}$								64	154	64
			$n_{2 \text{ th}}$								64	154	64
24.933	703	3.38	M_2	127	99	237	189	177	323	263			
			c	5.3	5.5	2.9	3.3	3.3	2.2	2.2			
			$n_{2 \text{ Eck}}$	78	162	60	120	141	78	162			
			$n_{2 \text{ th}}$	78	162	60	120	141	78	151			
24.933	1096	3.38	M_2								214	174	380
			c								4.9	5.1	2.8
			$n_{2 \text{ Eck}}$								60	144	60
			$n_{2 \text{ th}}$								60	144	60
28.333	799	3.32	M_2	145	113	269	215	201	367	299			
			c	5.3	5.5	2.9	3.3	3.3	2.2	2.2			
			$n_{2 \text{ Eck}}$	69	143	53	106	124	69	143			
			$n_{2 \text{ th}}$	69	143	53	106	124	69	133			
28.333	1245	3.32	M_2								243	197	432
			c								4.9	5.1	2.8
			$n_{2 \text{ Eck}}$								53	127	53
			$n_{2 \text{ th}}$								53	127	53
32.267	729	2.25	M_2	166	130	309	246	231	419	342			
			c	4.2	4.4	2.3	2.6	2.7	1.7	1.7			
			$n_{2 \text{ Eck}}$	60	126	47	93	109	60	126			
			$n_{2 \text{ th}}$	60	126	46	93	109	60	124			

$M \dots$ [Nm]
 $n \dots$ [min^{-1}]
 $J \dots$ [kgcm^2]

$P \dots$ [kW]
 $I \dots$ [A]
 $i \dots$ [-]
 $c \dots$ [-]

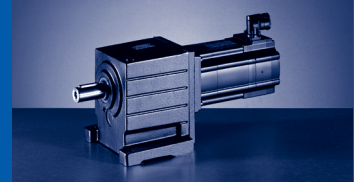

$M_{2GN} \leq 1373 \text{ Nm}$

14HC32	14LC15	14LC32	14PC14	14PC32	19FC14	19FC30	19JC14	19JC30	19PC14	19PC30	GST09-2S			
...500	...500	...500	...500	...500	...500	...500	...500	...500	...500	...500	M_1	J_G	M_{2GN}	i
14	23	17.2	30	21	27	21	40	29	51	32	n_1			
3225	1500	3225	1350	3225	1425	3000	1425	3000	1350	3000	I_{M230}			
											I_{M400}			
11.9	9.7	15	10.8	15.6	8.6	14	12.3	18.5	14.3	19	P_N			
4.7	3.6	5.8	4.2	7.1	4	6.6	6	9.1	7.2	10	J_M			
14.32	23.44	23.44	34.74	34.82	65.12	65.04	105.04	105.12	160.12	160.04	M_2			
199	331	246	435	303							c	7.65	996	15.156
4.3	3	3.5	2.3	2.8							$n_{2 \text{ Eck}}$			
213	99	213	89	213							$n_{2 \text{ th}}$			
197	99	189	89	182										
					387	300	580	418	744	463	M_2			
					3.4	3.9	2.3	2.8	1.8	2.6	c	7.65	1340	15.156
					94	198	94	198	89	198	$n_{2 \text{ Eck}}$			
					94	146	94	146	89	146	$n_{2 \text{ th}}$			
226	377	280	495	344							M_2			
4.3	3	3.5	2.3	2.8							c	7.49	1132	17.222
187	87	187	78	187							$n_{2 \text{ Eck}}$			
173	87	166	78	160							$n_{2 \text{ th}}$			
					442	342	661	477	847	527	M_2			
					3	3.5	2.1	2.6	1.6	2.3	c	7.49	1373	17.222
					83	174	83	174	78	174	$n_{2 \text{ Eck}}$			
					83	128	83	128	78	128	$n_{2 \text{ th}}$			
											M_2			
											c	4.5	675	20.533
											$n_{2 \text{ Eck}}$			
											$n_{2 \text{ th}}$			
272	452	337	593	413							M_2			
3.3	2.3	2.7	1.8	2.2							c	4.5	1055	20.533
157	73	157	66	157							$n_{2 \text{ Eck}}$			
157	73	157	66	156							$n_{2 \text{ th}}$			
											M_2			
											c	4.41	767	23.333
											$n_{2 \text{ Eck}}$			
											$n_{2 \text{ th}}$			
309	514	383	674	469							M_2			
3.3	2.3	2.7	1.8	2.2							c	4.41	1199	23.333
138	64	138	58	138							$n_{2 \text{ Eck}}$			
138	64	138	58	137							$n_{2 \text{ th}}$			
											M_2			
											c	3.38	703	24.933
											$n_{2 \text{ Eck}}$			
											$n_{2 \text{ th}}$			
332	551	410	722	503							M_2			
2.9	2	2.3	1.5	1.9							c	3.38	1096	24.933
129	60	129	54	129							$n_{2 \text{ Eck}}$			
129	60	129	54	129							$n_{2 \text{ th}}$			
											M_2			
											c	3.32	799	28.333
											$n_{2 \text{ Eck}}$			
											$n_{2 \text{ th}}$			
378	626	466	820	572							M_2			
2.9	2	2.3	1.5	1.9							c	3.32	1245	28.333
114	53	114	48	114							$n_{2 \text{ Eck}}$			
114	53	114	48	114							$n_{2 \text{ th}}$			
											M_2			
											c	2.25	729	32.267
											$n_{2 \text{ Eck}}$			
											$n_{2 \text{ th}}$			

$M \dots$ [Nm]
 $n \dots$ [min^{-1}]
 $J \dots$ [kgcm^2]

$P \dots$ [kW]
 $I \dots$ [A]
 $i [-]$
 $c [-]$

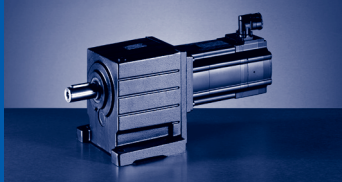

GST [Nm]

GST□□-□S (MCS)

$M_{2GN} \leq 1373 \text{ Nm}$

GST09-2S				12DC20	12DC41	12HC15	12HC30	12HC35	12LC20	12LC41	14DC15	14DC36	14HC15
				...500	...500	...500	...500	...500	...500	...500	...500	...500	...500
i	M_{2GN}	J_G	M_1	5.5	4.3	10	8	7.5	13.5	11	9.2	7.5	16
			n_1	1950	4050	1500	3000	3525	1950	4050	1500	3600	1500
			I_{M230}	5.2	8.8	7.6	10.5		11.8				
			I_{M400}	2.6	4.5	3.8		5.7	5.9	10.2	4.5	7.5	6.6
			P_N	1.1	1.8	1.6	2.5	2.8	2.8	4.7	1.45	2.8	2.5
			J_M	4.12	4.12	7.42	7.42	7.42	10.72	10.72	8.22	8.22	14.32
32.267	1136	2.25	M_2								279	227	494
			c								4	4.1	2.3
			$n_{2 \text{ Eck}}$								47	112	47
			$n_{2 \text{ th}}$								46	111	46
36.667	829	2.21	M_2	189	148	351	280	262	477	388			
			c	4.2	4.4	2.3	2.6	2.7	1.7	1.7			
			$n_{2 \text{ Eck}}$	53	111	41	82	96	53	111			
			$n_{2 \text{ th}}$	53	110	41	82	96	53	109			
36.667	1291	2.21	M_2								317	258	562
			c								4	4.1	2.3
			$n_{2 \text{ Eck}}$								41	98	41
			$n_{2 \text{ th}}$								41	98	41
39.16	738	1.64	M_2	204	159	376	300	281	511	416			
			c	3.5	3.7	1.9	2.2	2.2	1.4	1.4			
			$n_{2 \text{ Eck}}$	50	103	38	77	90	50	103			
			$n_{2 \text{ th}}$	50	103	38	77	90	50	103			
39.16	1150	1.64	M_2								341	278	602
			c								3.3	3.4	1.9
			$n_{2 \text{ Eck}}$								38	92	38
			$n_{2 \text{ th}}$								38	92	38
44.5	839	1.62	M_2	231	180	428	340	319	580	472			
			c	3.5	4.1	1.9	2.4	2.5	1.4	1.6			
			$n_{2 \text{ Eck}}$	44	91	34	67	79	44	91			
			$n_{2 \text{ th}}$	44	91	34	67	79	44	91			
44.5	1307	1.62	M_2								388	314	684
			c								3.3	3.8	1.9
			$n_{2 \text{ Eck}}$								34	81	34
			$n_{2 \text{ th}}$								34	81	34
49.5	748	1.12	M_2	259	202	478	380	357	647	527			
			c	2.8	3.3	1.6	2	2	1.2	1.3			
			$n_{2 \text{ Eck}}$	39	82	30	61	71	39	82			
			$n_{2 \text{ th}}$	39	82	30	61	71	39	82			
56.25	850	1.1	M_2	294	229	543	432	405	736	599			
			c	2.8	3.3	1.6	2	2	1.2	1.3			
			$n_{2 \text{ Eck}}$	35	72	27	53	63	35	72			
			$n_{2 \text{ th}}$	35	72	27	53	63	35	72			

$M \dots$ [Nm]
 $n \dots$ [min^{-1}]
 $J \dots$ [kgcm^2]

$P \dots$ [kW]
 $I \dots$ [A]
 $i \dots$ [-]
 $c \dots$ [-]

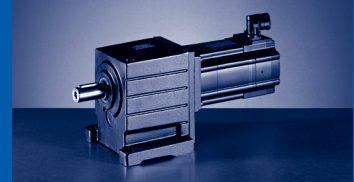

$M_{2GN} \leq 1373 \text{ Nm}$

14HC32	14LC15	14LC32	14PC14	14PC32	19FC14	19FC30	19JC14	19JC30	19PC14	19PC30	GST09-2S			
...S00	...S00	...S00	...S00	...S00	...S00	...S00	...S00	...S00	...S00	...S00	M_1	J_G	M_{2GN}	i
14	23	17.2	30	21	27	21	40	29	51	32	n_1			
3225	1500	3225	1350	3225	1425	3000	1425	3000	1350	3000	I_{M230}			
											I_{M400}			
11.9	9.7	15	10.8	15.6	8.6	14	12.3	18.5	14.3	19	P_N			
4.7	3.6	5.8	4.2	7.1	4	6.6	6	9.1	7.2	10	J_M			
14.32	23.44	23.44	34.74	34.82	65.12	65.04	105.04	105.12	160.12	160.04	M_2			
432	716	534	937	654							c	2.25	1136	32.267
2.3	1.6	1.9	1.2	1.5							$n_{2 \text{ Eck}}$			
100	47	100	42	100							$n_{2 \text{ th}}$			
100	46	100	42	100							M_2			
											c	2.21	829	36.667
											$n_{2 \text{ Eck}}$			
											$n_{2 \text{ th}}$			
491	813	606	1065	743							M_2			
2.3	1.6	1.9	1.2	1.5							c	2.21	1291	36.667
88	41	88	37	88							$n_{2 \text{ Eck}}$			
88	41	88	37	88							$n_{2 \text{ th}}$			
											M_2			
											c	1.64	738	39.16
											$n_{2 \text{ Eck}}$			
											$n_{2 \text{ th}}$			
527	871	650	1140	796							M_2			
1.9	1.3	1.6	1	1.3							c	1.64	1150	39.16
82	38	82	35	82							$n_{2 \text{ Eck}}$			
82	38	82	34	82							$n_{2 \text{ th}}$			
											M_2			
											c	1.62	839	44.5
											$n_{2 \text{ Eck}}$			
											$n_{2 \text{ th}}$			
598	990	737	1295	903							M_2			
2.1	1.3	1.7	1	1.4							c	1.62	1307	44.5
73	34	73	30	73							$n_{2 \text{ Eck}}$			
72	34	72	30	72							$n_{2 \text{ th}}$			
											M_2			
											c	1.12	748	49.5
											$n_{2 \text{ Eck}}$			
											$n_{2 \text{ th}}$			
											M_2			
											c	1.1	850	56.25
											$n_{2 \text{ Eck}}$			
											$n_{2 \text{ th}}$			

M ... [Nm]
n ... [min⁻¹]
J ... [kgcm²]

P ... [kW]
I ... [A]
i [-]
c [-]

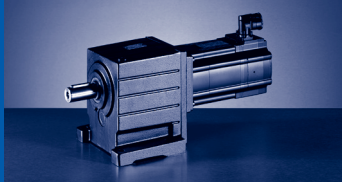

GST [Nm]

GST□□-□S (MCS)

$M_{2GN} \leq 1623 \text{ Nm}$

GST09-3S				06FC41	06IC41	09DC41	09FC38	09HC41	09LC41	12DC20	12DC41	12HC15	12HC30
				...500	...500	...500	...500	...500	...500	...500	...500	...500	...500
i	M_{2GN}	J_G	M_1	1.2	1.5	2.3	3.1	3.8	4.5	5.5	4.3	10	8
			n_1	4050	4050	4050	3750	4050	4050	1950	4050	1500	3000
			I_{M230}	2.9	3.2	4.6	5	6.8	8.4	5.2	8.8	7.6	10.5
			I_{M400}	1.5	1.6	2.3	2.5	3.4	4.2	2.6	4.5	3.8	
			P_N	0.51	0.64	1	1.2	1.6	1.9	1.1	1.8	1.6	2.5
			J_M	0.25	0.33	1.13	1.53	1.93	2.83	4.12	4.12	7.42	7.42
40.136	964	2.14	M_2					139	166				
			c					5.4	4.6				
			n_2 Eck					101	101				
			n_2 th					101	101				
40.136	1245	2.14	M_2							200		375	298
			c							5.9		3.3	3.7
			n_2 Eck							49		37	75
			n_2 th							49		37	75
40.136	1344	2.14	M_2										
			c										
			n_2 Eck										
			n_2 th										
43.267	892	1.55	M_2					150	180				
			c					5.1	4.3				
			n_2 Eck					94	94				
			n_2 th					94	94				
43.267	1152	1.55	M_2							218	169	406	322
			c							5.1	5.9	2.8	3.5
			n_2 Eck							45	94	35	69
			n_2 th							45	94	35	69
43.267	1290	1.55	M_2										
			c										
			n_2 Eck										
			n_2 th										
49.167	1013	1.53	M_2					171	204				
			c					5.1	4.3				
			n_2 Eck					82	82				
			n_2 th					82	82				
49.167	1310	1.53	M_2							247	192	461	366
			c							5.1	5.9	2.8	3.5
			n_2 Eck							40	82	31	61
			n_2 th							40	82	31	61
49.167	1466	1.53	M_2										
			c										
			n_2 Eck										
			n_2 th										
53.044	1093	1.38	M_2					184	220				
			c					5.1	4.3				
			n_2 Eck					76	76				
			n_2 th					76	76				
53.044	1379	1.38	M_2							267	207	498	395
			c							5	5.7	2.7	3.4
			n_2 Eck							37	76	28	57
			n_2 th							37	76	28	57
60.278	1242	1.37	M_2					209	250				
			c					5.1	4.3				
			n_2 Eck					67	67				
			n_2 th					67	67				
60.278	1565	1.37	M_2							304	235	566	449
			c							4.9	5.7	2.7	3.4
			n_2 Eck							32	67	25	50
			n_2 th							32	67	25	50

$M \dots$ [Nm]
 $n \dots$ [min^{-1}]
 $J \dots$ [kgcm^2]

$P \dots$ [kW]
 $I \dots$ [A]
 $i \dots$ [-]
 $c \dots$ [-]

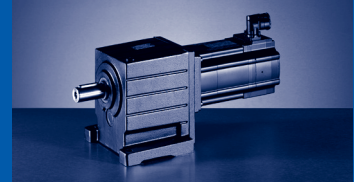

$M_{2GN} \leq 1623 \text{ Nm}$

12HC35	12LC20	12LC41	14DC15	14DC36	14HC15	14HC32	14LC15	14LC32	14PC14	14PC32	GST09-3S			
...S00	...S00	...S00	...S00	...S00	...S00	...S00	...S00	...S00	...S00	...S00	M_1	J_G	M_{2GN}	i
7.5	13.5	11	9.2	7.5	16	14	23	17.2	30	21	n_1			
3525	1950	4050	1500	3600	1500	3225	1500	3225	1350	3225	I_{M230}			
	11.8										I_{M400}			
5.7	5.9	10.2	4.5	7.5	6.6	11.9	9.7	15	10.8	15.6	P_N			
2.8	2.8	4.7	1.45	2.8	2.5	4.7	3.6	5.8	4.2	7.1	J_M			
7.42	10.72	10.72	8.22	8.22	14.32	14.32	23.44	23.44	34.74	34.82	M_2			
											c	2.14	964	40.136
											$n_{2 \text{ Eck}}$			
											$n_{2 \text{ th}}$			
280	510	416									M_2			
3.7	2.4	2.4									c	2.14	1245	40.136
88	49	101									$n_{2 \text{ Eck}}$			
88	49	101									$n_{2 \text{ th}}$			
			343	279	606	530	877	654	1149	802	M_2			
			3.8	4	2.2	2.2	1.5	1.8	1.2	1.5	c	2.14	1344	40.136
			37	90	37	80	37	80	34	80	$n_{2 \text{ Eck}}$			
			37	89	37	80	37	80	34	80	$n_{2 \text{ th}}$			
											M_2			
											c	1.55	892	43.267
											$n_{2 \text{ Eck}}$			
											$n_{2 \text{ th}}$			
302	552	449									M_2			
3.5	2.1	2.3									c	1.55	1152	43.267
82	45	94									$n_{2 \text{ Eck}}$			
81	45	94									$n_{2 \text{ th}}$			
			371	301	655	572	947	705	1240	864	M_2			
			3.4	3.9	2	2.2	1.4	1.8	1	1.5	c	1.55	1290	43.267
			35	83	35	75	35	75	31	75	$n_{2 \text{ Eck}}$			
			35	83	35	75	35	75	31	75	$n_{2 \text{ th}}$			
											M_2			
											c	1.53	1013	49.167
											$n_{2 \text{ Eck}}$			
											$n_{2 \text{ th}}$			
343	627	510									M_2			
3.5	2.1	2.3									c	1.53	1310	49.167
72	40	82									$n_{2 \text{ Eck}}$			
72	40	82									$n_{2 \text{ th}}$			
			421	342	744	650	1077	802	1409	982	M_2			
			3.4	3.9	2	2.2	1.4	1.8	1	1.5	c	1.53	1466	49.167
			31	73	31	66	31	66	28	66	$n_{2 \text{ Eck}}$			
			31	73	31	66	31	66	27	66	$n_{2 \text{ th}}$			
											M_2			
											c	1.38	1093	53.044
											$n_{2 \text{ Eck}}$			
											$n_{2 \text{ th}}$			
371	677	550	457	371	805	703	1164	867		1062	M_2			
3.4	2	2.2	3	3.4	1.7	1.9	1.2	1.5		1.3	c	1.38	1379	53.044
67	37	76	28	68	28	61	28	61		61	$n_{2 \text{ Eck}}$			
66	37	76	28	68	28	61	28	61		61	$n_{2 \text{ th}}$			
											M_2			
											c	1.37	1242	60.278
											$n_{2 \text{ Eck}}$			
											$n_{2 \text{ th}}$			
421	769	625	519	421	915	799	1322	985		1206	M_2			
3.4	2	2.2	3	3.4	1.7	1.9	1.2	1.5		1.3	c	1.37	1565	60.278
59	32	67	25	60	25	54	25	54		54	$n_{2 \text{ Eck}}$			
58	32	67	25	60	25	54	25	54		54	$n_{2 \text{ th}}$			

$M \dots$ [Nm]
 $n \dots$ [min^{-1}]
 $J \dots$ [kgcm^2]

$P \dots$ [kW]
 $I \dots$ [A]
 $i [-]$
 $c [-]$

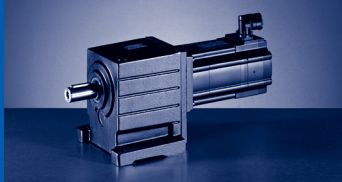

GST [Nm]

GST□□-□S (MCS)

$M_{2GN} \leq 1623 \text{ Nm}$

GST09-3S				06FC41	06IC41	09DC41	09FC38	09HC41	09LC41	12DC20	12DC41	12HC15	12HC30
				...500	...500	...500	...500	...500	...500	...500	...500	...500	...500
i	M_{2GN}	J_G	M_1	1.2	1.5	2.3	3.1	3.8	4.5	5.5	4.3	10	8
			n_1	4050	4050	4050	3750	4050	4050	1950	4050	1500	3000
			I_{M230}	2.9	3.2	4.6	5	6.8	8.4	5.2	8.8	7.6	10.5
			I_{M400}	1.5	1.6	2.3	2.5	3.4	4.2	2.6	4.5	3.8	
			P_N	0.51	0.64	1	1.2	1.6	1.9	1.1	1.8	1.6	2.5
			J_M	0.25	0.33	1.13	1.53	1.93	2.83	4.12	4.12	7.42	7.42
71.867	1477	1.17	M_2					250	298	366	284	679	540
			c					5.1	4.3	3.9	4.5	2.2	2.7
			$n_{2 \text{ Eck}}$					56	56	27	56	21	42
			$n_{2 \text{ th}}$					56	56	27	56	21	42
81.667	1584	1.16	M_2					285	340	417	324	772	614
			c					4.8	4.1	3.7	4.3	2	2.5
			$n_{2 \text{ Eck}}$					50	50	24	50	18	37
			$n_{2 \text{ th}}$					50	50	24	50	18	37
93.541	1545	0.71	M_2			265	329	392					
			c			5.2	4.1	3.5					
			$n_{2 \text{ Eck}}$			40	43	43					
			$n_{2 \text{ th}}$			40	43	43					
93.541	1613	0.71	M_2							480	373	886	706
			c							3.3	3.8	1.8	2.3
			$n_{2 \text{ Eck}}$							21	43	16	32
			$n_{2 \text{ th}}$							21	43	16	32
99.167	1596	1.07	M_2			281	349	416	510	397	941	749	
			c			5	4	3.4	3.1	3.5	1.7	2.1	
			$n_{2 \text{ Eck}}$			38	41	41	20	41	15	30	
			$n_{2 \text{ th}}$			38	41	41	20	41	15	30	
113.585	1613	0.65	M_2			237	324	402	478	586	456	1080	861
			c			5.9	4.5	3.5	3	2.7	3.1	1.5	1.9
			$n_{2 \text{ Eck}}$			36	33	36	36	17	36	13	26
			$n_{2 \text{ th}}$			36	33	36	36	17	36	13	26
129.074	1612	0.65	M_2			271	371	458	546	669	521	1230	980
			c			5.1	3.9	3.1	2.6	2.4	2.8	1.3	1.6
			$n_{2 \text{ Eck}}$			31	29	31	31	15	31	12	23
			$n_{2 \text{ th}}$			31	29	31	31	15	31	12	23
141.289	1316	0.46	M_2		192								
			c		5.9								
			$n_{2 \text{ Eck}}$		29								
			$n_{2 \text{ th}}$		29								
141.289	1613	0.46	M_2			299	407	503	599	734	571	1348	1075
			c			4.7	3.6	2.8	2.4	2.2	2.5	1.2	1.5
			$n_{2 \text{ Eck}}$			29	27	29	29	14	29	11	21
			$n_{2 \text{ th}}$			29	27	29	29	14	29	11	21
160.556	1495	0.46	M_2		218								
			c		5.9								
			$n_{2 \text{ Eck}}$		25								
			$n_{2 \text{ th}}$		25								
160.556	1623	0.46	M_2			341	465	574	682	836	651	1533	1223
			c			4.2	3.2	2.5	2.1	1.9	2.2	1.1	1.3
			$n_{2 \text{ Eck}}$			25	23	25	25	12	25	9	19
			$n_{2 \text{ th}}$			25	23	25	25	12	25	9	19
182.844	1365	0.3	M_2	199	252								
			c	5.9	4.7								
			$n_{2 \text{ Eck}}$	22	22								
			$n_{2 \text{ th}}$	22	22								
182.844	1613	0.3	M_2			391	532	656	779				
			c			3.6	2.8	2.2	1.9				
			$n_{2 \text{ Eck}}$			22	21	22	22				
			$n_{2 \text{ th}}$			22	21	22	22				

$M \dots [\text{Nm}]$
 $n \dots [\text{min}^{-1}]$
 $J \dots [\text{kgcm}^2]$

$P \dots [\text{kW}]$
 $I \dots [\text{A}]$
 $i \dots [-]$
 $c \dots [-]$



$M_{2GN} \leq 1623 \text{ Nm}$

12HC35	12LC20	12LC41	14DC15	14DC36	14HC15	14HC32	14LC15	14LC32	14PC14	14PC32	GST09-3S			
...S00	...S00	...S00	...S00	...S00	...S00	...S00	...S00	...S00	...S00	...S00	M_1	J_G	M_{2GN}	i
7.5	13.5	11	9.2	7.5	16	14	23	17.2	30	21	n_1			
3525	1950	4050	1500	3600	1500	3225	1500	3225	1350	3225	I_{M230}			
	11.8										I_{M400}			
5.7	5.9	10.2	4.5	7.5	6.6	11.9	9.7	15	10.8	15.6	P_N			
2.8	2.8	4.7	1.45	2.8	2.5	4.7	3.6	5.8	4.2	7.1	J_M			
7.42	10.72	10.72	8.22	8.22	14.32	14.32	23.44	23.44	34.74	34.82	M_2			
506	921	749	623	506	1095	957		1179			c	1.17	1477	71.867
2.7	1.6	1.8	2.3	2.7	1.3	1.5		1.2			$n_{2 \text{ Eck}}$			
49	27	56	21	50	21	45		45			$n_{2 \text{ th}}$			
49	27	56	21	50	21	45		45						
576	1048	853	709	576	1245	1088		1340			M_2	1.16	1584	81.667
2.6	1.5	1.7	2.2	2.6	1.3	1.4		1.2			c			
43	24	50	18	44	18	40		40			$n_{2 \text{ Eck}}$			
43	24	50	18	44	18	39		39			$n_{2 \text{ th}}$			
											M_2	0.71	1545	93.541
											c			
											$n_{2 \text{ Eck}}$			
											$n_{2 \text{ th}}$			
661	1203	978									M_2	0.71	1613	93.541
2.3	1.3	1.5									c			
38	21	43									$n_{2 \text{ Eck}}$			
38	21	43									$n_{2 \text{ th}}$			
702	1276	1038	864	703	1516	1324					M_2	1.07	1596	99.167
2.1	1.3	1.4	1.8	2.1	1.1	1.2					c			
36	20	41	15	36	15	33					$n_{2 \text{ Eck}}$			
36	20	41	15	36	15	33					$n_{2 \text{ th}}$			
807	1464	1191									M_2	0.65	1613	113.585
1.9	1.1	1.2									c			
31	17	36									$n_{2 \text{ Eck}}$			
31	17	36									$n_{2 \text{ th}}$			
919		1356									M_2	0.65	1612	129.074
1.7		1.1									c			
27		31									$n_{2 \text{ Eck}}$			
27		31									$n_{2 \text{ th}}$			
											M_2	0.46	1316	141.289
											c			
											$n_{2 \text{ Eck}}$			
											$n_{2 \text{ th}}$			
1007											M_2	0.46	1613	141.289
1.5											c			
25											$n_{2 \text{ Eck}}$			
25											$n_{2 \text{ th}}$			
											M_2	0.46	1495	160.556
											c			
											$n_{2 \text{ Eck}}$			
											$n_{2 \text{ th}}$			
1147											M_2	0.46	1623	160.556
1.3											c			
22											$n_{2 \text{ Eck}}$			
22											$n_{2 \text{ th}}$			
											M_2	0.3	1365	182.844
											c			
											$n_{2 \text{ Eck}}$			
											$n_{2 \text{ th}}$			
											M_2	0.3	1613	182.844
											c			
											$n_{2 \text{ Eck}}$			
											$n_{2 \text{ th}}$			

$M \dots$ [Nm]
 $n \dots$ [min^{-1}]
 $J \dots$ [kgcm^2]

$P \dots$ [kW]
 $I \dots$ [A]
 i [-]
 c [-]

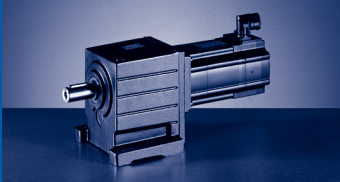

GST [Nm]

GST□□-□S (MCS)

$M_{2GN} \leq 1623 \text{ Nm}$

GST09-3S				06FC41	06IC41	09DC41	09FC38	09HC41	09LC41	12DC20	12DC41	12HC15	12HC30	
				...500	...500	...500	...500	...500	...500	...500	...500	...500	...500	
i	M_{2GN}	J_G	M_1	1.2	1.5	2.3	3.1	3.8	4.5	5.5	4.3	10	8	
			n_1	4050	4050	4050	3750	4050	4050	1950	4050	1500	3000	
			I_{M230}	2.9	3.2	4.6	5	6.8	8.4	5.2	8.8	7.6	10.5	
			I_{M400}	1.5	1.6	2.3	2.5	3.4	4.2	2.6	4.5	3.8		
			P_N	0.51	0.64	1	1.2	1.6	1.9	1.1	1.8	1.6	2.5	
			J_M	0.25	0.33	1.13	1.53	1.93	2.83	4.12	4.12	7.42	7.42	
207.778	1551	0.3	M_2	226	286									
			c	5.9	4.7									
			$n_{2 \text{ Eck}}$	20	20									
			$n_{2 \text{ th}}$	19	19									
207.778	1623	0.3	M_2			446	606	747	888					
			c			3.2	2.5	2	1.6					
			$n_{2 \text{ Eck}}$			20	18	20	20					
			$n_{2 \text{ th}}$			19	18	19	19					
236.622	1613	0.28	M_2	259	327	510	693	853	1013					
			c	5.4	4.3	2.8	2.1	1.7	1.4					
			$n_{2 \text{ Eck}}$	17	17	17	16	17	17					
			$n_{2 \text{ th}}$	17	17	17	16	17	17					
252.167	1569	0.21	M_2	277	350									
			c	4.9	3.9									
			$n_{2 \text{ Eck}}$	16	16									
			$n_{2 \text{ th}}$	16	16									
252.167	1623	0.21	M_2			545	739	910	1080					
			c			2.7	2	1.6	1.4					
			$n_{2 \text{ Eck}}$			16	15	16	16					
			$n_{2 \text{ th}}$			16	15	16	16					
268.889	1623	0.28	M_2	296	374	582	789	971	1153					
			c	4.8	3.8	2.5	1.9	1.5	1.3					
			$n_{2 \text{ Eck}}$	15	15	15	14	15	15					
			$n_{2 \text{ th}}$	15	15	15	14	15	15					
326.333	1623	0.2	M_2	363	457	709	961	1182	1403					
			c	3.9	3.1	2.1	1.6	1.2	1.1					
			$n_{2 \text{ Eck}}$	12	12	12	12	12	12					
			$n_{2 \text{ th}}$	12	12	12	11	12	12					
363	1613	0.26	M_2	405	511									
			c	3.5	2.8									
			$n_{2 \text{ Eck}}$	11	11									
			$n_{2 \text{ th}}$	11	11									
412.5	1623	0.18	M_2	463	582									
			c	3.1	2.5									
			$n_{2 \text{ Eck}}$	10	10									
			$n_{2 \text{ th}}$	10	10									

M ... [Nm]
 n ... [min⁻¹]
 J ... [kgcm²]

P ... [kW]
 I ... [A]
 i [-]
 c [-]

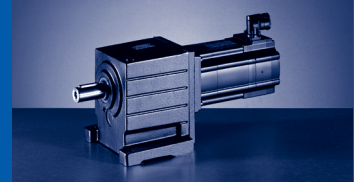

$M_{2GN} \leq 1623 \text{ Nm}$

12HC35	12LC20	12LC41	14DC15	14DC36	14HC15	14HC32	14LC15	14LC32	14PC14	14PC32	GST09-3S			
...S00	...S00	...S00	...S00	...S00	...S00	...S00	...S00	...S00	...S00	...S00	M_1	J_G	M_{2GN}	i
7.5	13.5	11	9.2	7.5	16	14	23	17.2	30	21	n_1			
3525	1950	4050	1500	3600	1500	3225	1500	3225	1350	3225	I_{M230}			
	11.8										I_{M400}			
5.7	5.9	10.2	4.5	7.5	6.6	11.9	9.7	15	10.8	15.6	P_N			
2.8	2.8	4.7	1.45	2.8	2.5	4.7	3.6	5.8	4.2	7.1	J_M			
7.42	10.72	10.72	8.22	8.22	14.32	14.32	23.44	23.44	34.74	34.82	M_2			
											c	0.3	1551	207.778
											$n_{2 \text{ Eck}}$			
											$n_{2 \text{ th}}$			
											M_2	0.3	1623	207.778
											c			
											$n_{2 \text{ Eck}}$			
											$n_{2 \text{ th}}$			
											M_2	0.28	1613	236.622
											c			
											$n_{2 \text{ Eck}}$			
											$n_{2 \text{ th}}$			
											M_2	0.21	1569	252.167
											c			
											$n_{2 \text{ Eck}}$			
											$n_{2 \text{ th}}$			
											M_2	0.21	1623	252.167
											c			
											$n_{2 \text{ Eck}}$			
											$n_{2 \text{ th}}$			
											M_2	0.28	1623	268.889
											c			
											$n_{2 \text{ Eck}}$			
											$n_{2 \text{ th}}$			
											M_2	0.2	1623	326.333
											c			
											$n_{2 \text{ Eck}}$			
											$n_{2 \text{ th}}$			
											M_2	0.26	1613	363
											c			
											$n_{2 \text{ Eck}}$			
											$n_{2 \text{ th}}$			
											M_2	0.18	1623	412.5
											c			
											$n_{2 \text{ Eck}}$			
											$n_{2 \text{ th}}$			

M ... [Nm]
n ... [min⁻¹]
J ... [kgcm²]

P ... [kW]
I ... [A]
i [-]
c [-]

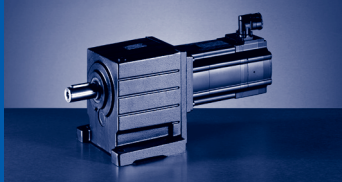

GST [Nm]

GST□□-□S (MCS)

$M_{2GN} \leq 2396 \text{ Nm}$

GST11-2S				14DC15	14DC36	14HC15	14HC32	14LC15	14LC32	14PC14
				...500	...500	...500	...500	...500	...500	...500
i	M_{2GN}	J_G	M_1							
			n_1	9.2	7.5	16	14	23	17.2	30
			I_{M400}	1500	3600	1500	3225	1500	3225	1350
			P_N	4.5	7.5	6.6	11.9	9.7	15	10.8
			J_M	1.45	2.8	2.5	4.7	3.6	5.8	4.2
			J_M	8.22	8.22	14.32	14.32	23.44	23.44	34.74
4.056	888	82.2	M_2 c n_2 Eck n_2 th							
4.457	976	79	M_2 c n_2 Eck n_2 th							
5.324	982	55.4	M_2 c n_2 Eck n_2 th							
5.85	1080	53.5	M_2 c n_2 Eck n_2 th							
6.4	1118	45.7	M_2 c n_2 Eck n_2 th							
6.864	1502	67.5	M_2 c n_2 Eck n_2 th							
7.8	1707	65.1	M_2 c n_2 Eck n_2 th							
9.01	1663	46.8	M_2 c n_2 Eck n_2 th							
9.856	1721	40.2	M_2 c n_2 Eck n_2 th							
11.2	1956	39	M_2 c n_2 Eck n_2 th							
12.571	1191	29.4	M_2 c n_2 Eck n_2 th				163 5.4 257 186	271 4.2 119 119	202 4.4 257 178	357 3.3 107 107
12.571	1849	29.4	M_2 c n_2 Eck n_2 th							
14.286	1353	28.7	M_2 c n_2 Eck n_2 th				185 5.4 226 164	308 4.2 105 105	230 4.4 226 157	406 3.3 95 95

$M \dots$ [Nm]
 $n \dots$ [min^{-1}]
 $J \dots$ [kgcm^2]

$P \dots$ [kW]
 $I \dots$ [A]
 i [-]
 c [-]

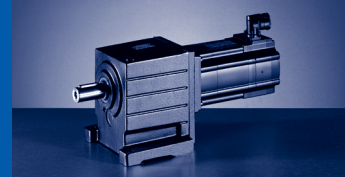

$M_{2GN} \leq 2396 \text{ Nm}$

14PC32	19FC14	19FC30	19JC14	19JC30	19PC14	19PC30	GST11-2S			
...500	...500	...500	...500	...500	...500	...500				
21	27	21	40	29	51	32	M_1	J_G	M_{2GN}	i
3225	1425	3000	1425	3000	1350	3000	n_1			
15.6	8.6	14	12.3	18.5	14.3	19	I_{M400}			
7.1	4	6.6	6	9.1	7.2	10	P_N			
34.82	65.12	65.04	105.04	105.12	160.12	160.04	J_M			
			150		194	120	M_2			
			5.6		4.4	5.6	c	82.2	888	4.056
			351		333	740	$n_{2 \text{ Eck}}$			
			351		333	428	$n_{2 \text{ th}}$			
			165		213	132	M_2			
			5.6		4.4	5.6	c	79	976	4.457
			320		303	673	$n_{2 \text{ Eck}}$			
			320		303	390	$n_{2 \text{ th}}$			
			199	143	256	159	M_2			
			4.8	5.2	3.7	4.7	c	55.4	982	5.324
			268	564	254	564	$n_{2 \text{ Eck}}$			
			268	374	254	365	$n_{2 \text{ th}}$			
			218	157	281	175	M_2			
			4.8	5.2	3.7	4.7	c	53.5	1080	5.85
			244	513	231	513	$n_{2 \text{ Eck}}$			
			244	340	231	333	$n_{2 \text{ th}}$			
			239	173	308	192	M_2			
			4.5	4.9	3.5	4.5	c	45.7	1118	6.4
			223	469	211	469	$n_{2 \text{ Eck}}$			
			223	316	211	310	$n_{2 \text{ th}}$			
			254		328	203	M_2			
			5.6		4.4	5.6	c	67.5	1502	6.864
			208		197	437	$n_{2 \text{ Eck}}$			
			208		197	253	$n_{2 \text{ th}}$			
			288		372	231	M_2			
			5.6		4.4	5.6	c	65.1	1707	7.8
			183		173	385	$n_{2 \text{ Eck}}$			
			183		173	223	$n_{2 \text{ th}}$			
			336	243	433	269	M_2			
			4.8	5.2	3.7	4.7	c	46.8	1663	9.01
			158	333	150	333	$n_{2 \text{ Eck}}$			
			158	221	150	216	$n_{2 \text{ th}}$			
			369	266	475	295	M_2			
			4.5	4.9	3.5	4.5	c	40.2	1721	9.856
			145	304	137	304	$n_{2 \text{ Eck}}$			
			145	205	137	201	$n_{2 \text{ th}}$			
			419	302	540	335	M_2			
			4.5	4.9	3.5	4.5	c	39	1956	11.2
			127	268	121	268	$n_{2 \text{ Eck}}$			
			127	181	121	177	$n_{2 \text{ th}}$			
249							M_2			
3.6							c	29.4	1191	12.571
257							$n_{2 \text{ Eck}}$			
171							$n_{2 \text{ th}}$			
	314	244	474	342	609	379	M_2			
	5.6	5.7	3.8	4.2	3	3.8	c	29.4	1849	12.571
	113	239	113	239	107	239	$n_{2 \text{ Eck}}$			
	113	176	113	176	107	173	$n_{2 \text{ th}}$			
283							M_2			
3.6							c	28.7	1353	14.286
226							$n_{2 \text{ Eck}}$			
150							$n_{2 \text{ th}}$			

M ... [Nm]
n ... [min⁻¹]
J ... [kgcm²]

P ... [kW]
I ... [A]
i [-]
c [-]

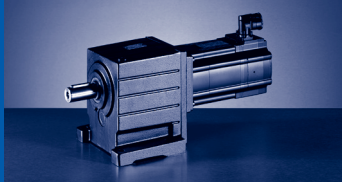

GST [Nm]

GST□□-□S (MCS)

$M_{2GN} \leq 2396 \text{ Nm}$

GST11-2S				14DC15	14DC36	14HC15	14HC32	14LC15	14LC32	14PC14
				...500	...500	...500	...500	...500	...500	...500
i	M_{2GN}	J_G	M_1	9.2	7.5	16	14	23	17.2	30
			n_1	1500	3600	1500	3225	1500	3225	1350
			I_{M400}	4.5	7.5	6.6	11.9	9.7	15	10.8
			P_N	1.45	2.8	2.5	4.7	3.6	5.8	4.2
			J_M	8.22	8.22	14.32	14.32	23.44	23.44	34.74
14.286	2101	28.7	M_2 c $n_{2 \text{ Eck}}$ $n_{2 \text{ th}}$							
15.4	1947	23	M_2 c $n_{2 \text{ Eck}}$ $n_{2 \text{ th}}$							
17.5	2212	22.5	M_2 c $n_{2 \text{ Eck}}$ $n_{2 \text{ th}}$							
20.289	1323	14.3	M_2 c $n_{2 \text{ Eck}}$ $n_{2 \text{ th}}$			305 4.2 74 74	266 4.2 159 147	444 2.9 74 74	330 3.4 159 141	583 2.2 67 67
20.289	2057	14.3	M_2 c $n_{2 \text{ Eck}}$ $n_{2 \text{ th}}$							
23.056	1503	14.1	M_2 c $n_{2 \text{ Eck}}$ $n_{2 \text{ th}}$			346 4.2 65 65	303 4.2 140 129	504 2.9 65 65	375 3.4 140 124	662 2.2 59 59
23.056	2338	14.1	M_2 c $n_{2 \text{ Eck}}$ $n_{2 \text{ th}}$							
24.933	1357	10.6	M_2 c $n_{2 \text{ Eck}}$ $n_{2 \text{ th}}$			377 3.5 60 60	330 3.5 129 129	548 2.4 60 60	408 2.9 129 129	719 1.9 54 54
24.933	2108	10.6	M_2 c $n_{2 \text{ Eck}}$ $n_{2 \text{ th}}$							
28.333	1542	10.4	M_2 c $n_{2 \text{ Eck}}$ $n_{2 \text{ th}}$			428 3.5 53 53	375 3.5 114 114	623 2.4 53 53	464 2.9 114 114	817 1.9 48 48
28.333	2396	10.4	M_2 c $n_{2 \text{ Eck}}$ $n_{2 \text{ th}}$							
32.267	1407	7.04	M_2 c $n_{2 \text{ Eck}}$ $n_{2 \text{ th}}$	276 4.9 47 46	225 5.1 112 111	492 2.8 47 46	430 2.8 100 100	713 2 47 46	531 2.3 100 100	934 1.5 42 42
36.667	1598	6.93	M_2 c $n_{2 \text{ Eck}}$ $n_{2 \text{ th}}$	314 4.9 41 41	256 5.1 98 98	559 2.8 41 41	489 2.8 88 88	810 2 41 41	604 2.3 88 88	1062 1.5 37 37

$M \dots$ [Nm]
 $n \dots$ [min^{-1}]
 $J \dots$ [kgcm^2]

$P \dots$ [kW]
 $I \dots$ [A]
 i [-]
 c [-]

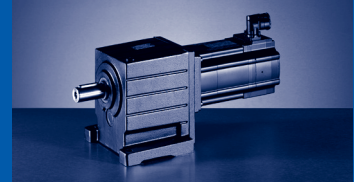

$M_{2GN} \leq 2396 \text{ Nm}$

14PC32	19FC14	19FC30	19JC14	19JC30	19PC14	19PC30	GST11-2S			
...500	...500	...500	...500	...500	...500	...500				
21	27	21	40	29	51	32	M_1	J_G	M_{2GN}	i
3225	1425	3000	1425	3000	1350	3000	n_1			
15.6	8.6	14	12.3	18.5	14.3	19	I_{M400}			
7.1	4	6.6	6	9.1	7.2	10	P_N			
34.82	65.12	65.04	105.04	105.12	160.12	160.04	J_M			
	356	277	538	389	693	431	M_2			
	5.6	5.7	3.8	4.2	3	3.8	c	28.7	2101	14.286
	100	210	100	210	95	210	$n_{2\text{ Eck}}$			
	100	155	100	155	95	152	$n_{2\text{ th}}$			
	388	299	584	420	750	465	M_2			
	4.8	5.6	3.3	4.1	2.6	3.7	c	23	1947	15.4
	93	195	93	195	88	195	$n_{2\text{ Eck}}$			
	93	144	93	144	88	144	$n_{2\text{ th}}$			
	440	340	663	477	852	528	M_2			
	4.8	5.6	3.3	4.1	2.6	3.7	c	22.5	2212	17.5
	81	171	81	171	77	171	$n_{2\text{ Eck}}$			
	81	126	81	126	77	126	$n_{2\text{ th}}$			
406							M_2			
2.8							c	14.3	1323	20.289
159							$n_{2\text{ Eck}}$			
136							$n_{2\text{ th}}$			
	516	399	774	558	993	617	M_2			
	3.9	4.5	2.6	3.3	2.1	3	c	14.3	2057	20.289
	70	148	70	148	67	148	$n_{2\text{ Eck}}$			
	70	109	70	109	67	109	$n_{2\text{ th}}$			
461							M_2			
2.8							c	14.1	1503	23.056
140							$n_{2\text{ Eck}}$			
119							$n_{2\text{ th}}$			
	586	453	880	634	1128	701	M_2			
	3.9	4.5	2.6	3.3	2.1	3	c	14.1	2338	23.056
	62	130	62	130	59	130	$n_{2\text{ Eck}}$			
	62	96	62	96	59	96	$n_{2\text{ th}}$			
501							M_2			
2.4							c	10.6	1357	24.933
129							$n_{2\text{ Eck}}$			
125							$n_{2\text{ th}}$			
	638	494	956	689	1225	762	M_2			
	3.2	3.7	2.2	2.7	1.7	2.5	c	10.6	2108	24.933
	57	120	57	120	54	120	$n_{2\text{ Eck}}$			
	57	89	57	89	54	89	$n_{2\text{ th}}$			
569							M_2			
2.4							c	10.4	1542	28.333
114							$n_{2\text{ Eck}}$			
110							$n_{2\text{ th}}$			
	725	561	1086	783	1392	866	M_2			
	3.2	3.7	2.2	2.7	1.7	2.5	c	10.4	2396	28.333
	50	106	50	106	48	106	$n_{2\text{ Eck}}$			
	50	78	50	78	48	78	$n_{2\text{ th}}$			
651							M_2			
1.9							c	7.04	1407	32.267
100							$n_{2\text{ Eck}}$			
100							$n_{2\text{ th}}$			
740							M_2			
1.9							c	6.93	1598	36.667
88							$n_{2\text{ Eck}}$			
88							$n_{2\text{ th}}$			

M ... [Nm]
n ... [min⁻¹]
J ... [kgcm²]

P ... [kW]
I ... [A]
i [-]
c [-]

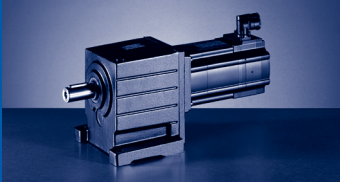

GST [Nm]

GST□□-□S (MCS)

$M_{2GN} \leq 2396 \text{ Nm}$

GST11-2S				14DC15	14DC36	14HC15	14HC32	14LC15	14LC32	14PC14
				...500	...500	...500	...500	...500	...500	...500
i	M_{2GN}	J_G	M_1	9.2	7.5	16	14	23	17.2	30
			n_1	1500	3600	1500	3225	1500	3225	1350
			I_{M400}	4.5	7.5	6.6	11.9	9.7	15	10.8
			P_N	1.45	2.8	2.5	4.7	3.6	5.8	4.2
			J_M	8.22	8.22	14.32	14.32	23.44	23.44	34.74
39.16	1424	5.15	M_2	338	275	599	524	868	647	1137
			c	4.1	4.2	2.3	2.4	1.6	1.9	1.3
			$n_{2 \text{ Eck}}$	38	92	38	82	38	82	35
			$n_{2 \text{ th}}$	38	92	38	82	38	82	34
44.5	1618	5.08	M_2	385	311	681	594	987	734	1292
			c	4.1	4.7	2.3	2.6	1.6	2.1	1.3
			$n_{2 \text{ Eck}}$	34	81	34	73	34	73	30
			$n_{2 \text{ th}}$	34	81	34	72	34	72	30
49.5	1441	3.52	M_2	432	350	761	665	1101	820	1441
			c	3.3	3.8	1.9	2.1	1.3	1.7	1
			$n_{2 \text{ Eck}}$	30	73	30	65	30	65	27
			$n_{2 \text{ th}}$	30	73	30	65	30	65	27
56.25	1637	3.44	M_2	490	398	865	755	1251	932	1637
			c	3.3	3.8	1.9	2.1	1.3	1.7	1
			$n_{2 \text{ Eck}}$	27	64	27	57	27	57	24
			$n_{2 \text{ th}}$	27	64	27	57	27	57	24

$M \dots$ [Nm]
 $n \dots$ [min^{-1}]
 $J \dots$ [kgcm^2]

$P \dots$ [kW]
 $I \dots$ [A]
 i [-]
 c [-]



$M_{2GN} \leq 2396 \text{ Nm}$

14PC32	19FC14	19FC30	19JC14	19JC30	19PC14	19PC30	GST11-2S			
...S00	...S00	...S00	...S00	...S00	...S00	...S00	M_1	J_G	M_{2GN}	i
21	27	21	40	29	51	32	n_1			
3225	1425	3000	1425	3000	1350	3000	I_{M400}			
15.6	8.6	14	12.3	18.5	14.3	19	P_N			
7.1	4	6.6	6	9.1	7.2	10	J_M			
34.82	65.12	65.04	105.04	105.12	160.12	160.04	M_2			
793							c			
1.6							$n_{2 \text{ Eck}}$	5.15	1424	39.16
82							$n_{2 \text{ th}}$			
82							M_2			
900							c			
1.7							$n_{2 \text{ Eck}}$	5.08	1618	44.5
73							$n_{2 \text{ th}}$			
72							M_2			
1004							c			
1.4							$n_{2 \text{ Eck}}$	3.52	1441	49.5
65							$n_{2 \text{ th}}$			
65							M_2			
1141							c			
1.4							$n_{2 \text{ Eck}}$	3.44	1637	56.25
57							$n_{2 \text{ th}}$			
57										

M ... [Nm]
n ... [min⁻¹]
J ... [kgcm²]

P ... [kW]
I ... [A]
i [-]
c [-]

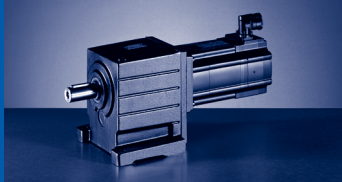

GST [Nm]

GST□□-□S (MCS)

$M_{2GN} \leq 2848 \text{ Nm}$

GST11-3S				09DC41	09FC38	09HC41	09LC41	12DC20	12DC41	12HC15	12HC30	12HC35
				...500	...500	...500	...500	...500	...500	...500	...500	...500
i	M_{2GN}	J_G	M_1	2.3	3.1	3.8	4.5	5.5	4.3	10	8	7.5
			n_1	4050	3750	4050	4050	1950	4050	1500	3000	3525
			I_{M230}	4.6	5	6.8	8.4	5.2	8.8	7.6	10.5	
			I_{M400}	2.3	2.5	3.4	4.2	2.6	4.5	3.8		5.7
			P_N	1	1.2	1.6	1.9	1.1	1.8	1.6	2.5	2.8
			J_M	1.13	1.53	1.93	2.83	4.12	4.12	7.42	7.42	7.42
40.816	1216	6.36	M_2 c $n_{2 \text{ Eck}}$ $n_{2 \text{ th}}$				167 5.7 99 99					
40.816	1565	6.36	M_2 c $n_{2 \text{ Eck}}$ $n_{2 \text{ th}}$						378 4 37 37	301 4.5 74 74	282 4.6 86 86	
40.816	2165	6.36	M_2 c $n_{2 \text{ Eck}}$ $n_{2 \text{ th}}$									
44	1687	5.66	M_2 c $n_{2 \text{ Eck}}$ $n_{2 \text{ th}}$						407 4 34 34	322 5 68 68	302 5.1 80 80	
44	2334	5.66	M_2 c $n_{2 \text{ Eck}}$ $n_{2 \text{ th}}$									
50	1917	5.6	M_2 c $n_{2 \text{ Eck}}$ $n_{2 \text{ th}}$						463 4 30 30	366 5 60 60	343 5.1 71 71	
50	2652	5.6	M_2 c $n_{2 \text{ Eck}}$ $n_{2 \text{ th}}$									
57.968	2222	4.77	M_2 c $n_{2 \text{ Eck}}$ $n_{2 \text{ th}}$						537 4 26 26	425 5 52 52	398 5.1 61 61	
57.968	2577	4.77	M_2 c $n_{2 \text{ Eck}}$ $n_{2 \text{ th}}$									
61.25	2017	4.08	M_2 c $n_{2 \text{ Eck}}$ $n_{2 \text{ th}}$						570 3.5 25 24	452 4.3 49 49	424 4.4 58 58	
61.25	2725	4.08	M_2 c $n_{2 \text{ Eck}}$ $n_{2 \text{ th}}$									
71.011	2339	3.52	M_2 c $n_{2 \text{ Eck}}$ $n_{2 \text{ th}}$						661 3.5 21 21	524 4.3 42 42	491 4.4 50 50	
71.011	2637	3.52	M_2 c $n_{2 \text{ Eck}}$ $n_{2 \text{ th}}$									

$M \dots$ [Nm]
 $n \dots$ [min^{-1}]
 $J \dots$ [kgcm^2]

$P \dots$ [kW]
 $I \dots$ [A]
 $i \dots$ [-]
 $c \dots$ [-]

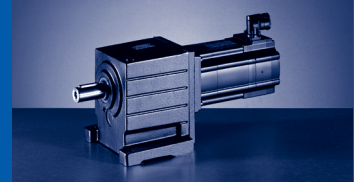

$M_{2GN} \leq 2848 \text{ Nm}$

12LC20	12LC41	14DC15	14DC36	14HC15	14HC32	14LC15	14LC32	14PC14	14PC32	GST11-3S			
...500	...500	...500	...500	...500	...500	...500	...500	...500	...500	M_1	J_G	M_{2GN}	i
13.5	11	9.2	7.5	16	14	23	17.2	30	21	n_1			
1950	4050	1500	3600	1500	3225	1500	3225	1350	3225	I_{M230}			
11.8										I_{M400}			
5.9	10.2	4.5	7.5	6.6	11.9	9.7	15	10.8	15.6	P_N			
2.8	4.7	1.45	2.8	2.5	4.7	3.6	5.8	4.2	7.1	J_M			
10.72	10.72	8.22	8.22	14.32	14.32	23.44	23.44	34.74	34.82	M_2			
										c			
										$n_{2 \text{ Eck}}$	6.36	1216	40.816
										$n_{2 \text{ th}}$			
516	420									M_2			
3	3									c			
48	99									$n_{2 \text{ Eck}}$	6.36	1565	40.816
48	99									$n_{2 \text{ th}}$			
				608	532	884	658	1160	808	M_2			
				3.5	3.5	2.4	2.8	1.9	2.3	c			
				37	79	37	79	33	79	$n_{2 \text{ Eck}}$	6.36	2165	40.816
				37	79	37	79	33	79	$n_{2 \text{ th}}$			
556	451									M_2			
3	3.3									c			
44	92									$n_{2 \text{ Eck}}$	5.66	1687	44
44	92									$n_{2 \text{ th}}$			
				655	571	953	707	1250	868	M_2			
				3.5	3.9	2.4	3.2	1.9	2.6	c			
				34	73	34	73	31	73	$n_{2 \text{ Eck}}$	5.66	2334	44
				34	73	34	73	31	73	$n_{2 \text{ th}}$			
632	513									M_2			
3	3.3									c			
39	81									$n_{2 \text{ Eck}}$	5.6	1917	50
39	81									$n_{2 \text{ th}}$			
				745	649	1083	803	1421	987	M_2			
				3.5	3.9	2.4	3.2	1.9	2.6	c			
				30	65	30	65	27	65	$n_{2 \text{ Eck}}$	5.6	2652	50
				30	65	30	65	27	65	$n_{2 \text{ th}}$			
732	595									M_2			
3	3.3									c			
34	70									$n_{2 \text{ Eck}}$	4.77	2222	57.968
34	70									$n_{2 \text{ th}}$			
		488	394	869	757	1261	937	1652	1149	M_2			
		5.1	5.8	2.9	3.2	2	2.6	1.6	2.2	c			
		26	62	26	56	26	56	23	56	$n_{2 \text{ Eck}}$	4.77	2577	57.968
		26	62	26	56	26	56	23	56	$n_{2 \text{ th}}$			
777	632									M_2			
2.6	2.8									c			
32	66									$n_{2 \text{ Eck}}$	4.08	2017	61.25
32	66									$n_{2 \text{ th}}$			
		516	417	918	800	1332	989	1746	1214	M_2			
		5.1	5.8	2.9	3.3	2	2.6	1.6	2.2	c			
		25	59	25	53	25	53	22	53	$n_{2 \text{ Eck}}$	4.08	2725	61.25
		24	59	24	53	24	53	22	53	$n_{2 \text{ th}}$			
901	732									M_2			
2.6	2.8									c			
28	57									$n_{2 \text{ Eck}}$	3.52	2339	71.011
27	57									$n_{2 \text{ th}}$			
		603	488	1070	933	1550	1153	2030	1413	M_2			
		4.2	4.9	2.4	2.7	1.7	2.2	1.3	1.8	c			
		21	51	21	45	21	45	19	45	$n_{2 \text{ Eck}}$	3.52	2637	71.011
		21	51	21	45	21	45	19	45	$n_{2 \text{ th}}$			

M ... [Nm]
n ... [min⁻¹]
J ... [kgcm²]

P ... [kW]
I ... [A]
i [-]
c [-]

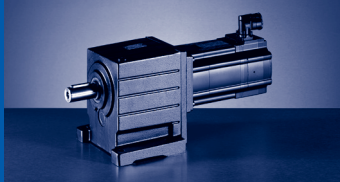

GST [Nm]

GST□□-□S (MCS)

$M_{2GN} \leq 2848 \text{ Nm}$

GST11-3S				09DC41	09FC38	09HC41	09LC41	12DC20	12DC41	12HC15	12HC30	12HC35
				...500	...500	...500	...500	...500	...500	...500	...500	...500
i	M_{2GN}	J_G	M_1	2.3	3.1	3.8	4.5	5.5	4.3	10	8	7.5
			n_1	4050	3750	4050	4050	1950	4050	1500	3000	3525
			I_{M230}	4.6	5	6.8	8.4	5.2	8.8	7.6	10.5	
			I_{M400}	2.3	2.5	3.4	4.2	2.6	4.5	3.8		5.7
			P_N	1	1.2	1.6	1.9	1.1	1.8	1.6	2.5	2.8
			J_M	1.13	1.53	1.93	2.83	4.12	4.12	7.42	7.42	7.42
80.694	2658	3.5	M_2 c $n_{2 \text{ Eck}}$ $n_{2 \text{ th}}$							751 3.5 19 19	596 4.3 37 37	558 4.4 44 44
80.694	2787	3.5	M_2 c $n_{2 \text{ Eck}}$ $n_{2 \text{ th}}$									
87.267	2657	3.22	M_2 c $n_{2 \text{ Eck}}$ $n_{2 \text{ th}}$					436 5.8 22 22		815 3.2 17 17	646 4 34 34	606 4 40 40
99.167	2810	3.2	M_2 c $n_{2 \text{ Eck}}$ $n_{2 \text{ th}}$					497 5.4 20 20		928 3 15 15	737 3.7 30 30	690 3.8 36 36
112.933	2695	2.93	M_2 c $n_{2 \text{ Eck}}$ $n_{2 \text{ th}}$					572 4.5 17 17	443 5.3 36 36	1062 2.5 13 13	844 3.1 27 27	791 3.2 31 31
129.074	2651	1.94	M_2 c $n_{2 \text{ Eck}}$ $n_{2 \text{ th}}$			449 5.1 31 31	536 4.3 31 31					
129.074	2810	1.94	M_2 c $n_{2 \text{ Eck}}$ $n_{2 \text{ th}}$					656 4.1 15 15	509 4.8 31 31	1217 2.3 12 12	968 2.9 23 23	907 2.9 27 27
146.993	2695	1.77	M_2 c $n_{2 \text{ Eck}}$ $n_{2 \text{ th}}$		414 5.8 26 26	514 4.6 28 28	613 3.9 28 28	753 3.5 13 13	585 4 28 28	1391 1.9 10 10	1107 2.4 20 20	1038 2.4 24 24
158.194	2779	1.4	M_2 c $n_{2 \text{ Eck}}$ $n_{2 \text{ th}}$		447 5.5 24 24	554 4.4 26 26	661 3.7 26 26					
158.194	2810	1.4	M_2 c $n_{2 \text{ Eck}}$ $n_{2 \text{ th}}$					811 3.4 12 12	630 3.9 26 26	1498 1.9 10 9	1193 2.3 19 19	1118 2.4 22 22
180.156	2695	1.29	M_2 c $n_{2 \text{ Eck}}$ $n_{2 \text{ th}}$		513 4.7 21 21	636 3.7 23 22	757 3.2 23 22	929 2.9 11 11	723 3.3 23 22	1712 1.6 8 8	1364 2 17 17	1278 2 20 20
207.778	2810	0.88	M_2 c $n_{2 \text{ Eck}}$ $n_{2 \text{ th}}$	435 5.6 20 19	595 4.2 18 18	736 3.4 20 19	876 2.9 20 19	1074 2.6 9 9	836 3 20 19	1977 1.4 7 7	1576 1.8 14 14	1477 1.8 17 17
236.622	2695	0.82	M_2 c $n_{2 \text{ Eck}}$ $n_{2 \text{ th}}$	500 4.7 17 17	682 3.6 16 16	843 2.8 17 17	1003 2.4 17 17	1229 2.2 8 8	957 2.5 17 17	2257 1.2 6 6	1800 1.5 13 13	1687 1.5 15 15

$M \dots [\text{Nm}]$
 $n \dots [\text{min}^{-1}]$
 $J \dots [\text{kgcm}^2]$

$P \dots [\text{kW}]$
 $I \dots [\text{A}]$
 $i \dots [-]$
 $c \dots [-]$

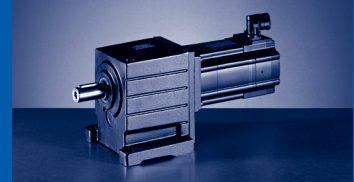

$M_{2GN} \leq 2848 \text{ Nm}$

12LC20	12LC41	14DC15	14DC36	14HC15	14HC32	14LC15	14LC32	14PC14	14PC32	GST11-3S			
...500	...500	...500	...500	...500	...500	...500	...500	...500	...500	M_1	J_G	M_{2GN}	i
13.5	11	9.2	7.5	16	14	23	17.2	30	21	n_1			
1950	4050	1500	3600	1500	3225	1500	3225	1350	3225	I_{M230}			
11.8										I_{M400}			
5.9	10.2	4.5	7.5	6.6	11.9	9.7	15	10.8	15.6	P_N			
2.8	4.7	1.45	2.8	2.5	4.7	3.6	5.8	4.2	7.1	J_M			
10.72	10.72	8.22	8.22	14.32	14.32	23.44	23.44	34.74	34.82	M_2			
1024	832									c			
2.6	2.8									$n_{2 \text{ Eck}}$	3.5	2658	80.694
24	50									$n_{2 \text{ th}}$			
24	50									M_2			
		688	557	1218	1062	1763	1312	2309	1608	c			
		3.9	4.5	2.3	2.5	1.6	2.1	1.2	1.7	$n_{2 \text{ Eck}}$	3.5	2787	80.694
		19	45	19	40	19	40	17	40	$n_{2 \text{ th}}$			
		19	44	19	40	19	40	17	40	M_2			
1110	902	747	606	1321	1153	1910	1422	2500	1743	c			
2.4	2.6	3.5	4	2	2.2	1.4	1.8	1.1	1.5	$n_{2 \text{ Eck}}$	3.22	2657	87.267
22	46	17	41	17	37	17	37	16	37	$n_{2 \text{ th}}$			
22	46	17	41	17	37	17	37	15	37	M_2			
1263	1027	852	691	1503	1312	2173	1618		1982	c			
2.2	2.4	3.2	3.7	1.9	2.1	1.3	1.7		1.4	$n_{2 \text{ Eck}}$	3.2	2810	99.167
20	41	15	36	15	33	15	33		33	$n_{2 \text{ th}}$			
20	41	15	36	15	33	15	33		33	M_2			
1444	1174	975	791	1717	1499	2480	1848		2263	c			
1.9	2.1	2.7	3.1	1.6	1.7	1.1	1.4		1.2	$n_{2 \text{ Eck}}$	2.93	2695	112.933
17	36	13	32	13	29	13	29		29	$n_{2 \text{ th}}$			
17	36	13	32	13	29	13	29		29	M_2			
										c			
										$n_{2 \text{ Eck}}$	1.94	2651	129.074
										$n_{2 \text{ th}}$			
1653	1344	1117	907	1965	1716		2115		2589	M_2			
1.7	1.9	2.5	2.9	1.4	1.6		1.3		1.1	c			
15	31	12	28	12	25		25		25	$n_{2 \text{ Eck}}$	1.94	2810	129.074
15	31	12	28	12	25		25		25	$n_{2 \text{ th}}$			
1888	1536	1278	1038	2243	1960		2414			M_2			
1.4	1.6	2.1	2.4	1.2	1.3		1.1			c			
13	28	10	25	10	22		22			$n_{2 \text{ Eck}}$	1.77	2695	146.993
13	28	10	24	10	22		22			$n_{2 \text{ th}}$			
										M_2			
										c			
										$n_{2 \text{ Eck}}$	1.4	2779	158.194
										$n_{2 \text{ th}}$			
2033	1654	1376	1118	2415	2110		2599			M_2			
1.4	1.5	2	2.3	1.2	1.3		1.1			c			
12	26	10	23	10	20		20			$n_{2 \text{ Eck}}$	1.4	2810	158.194
12	26	9	23	9	20		20			$n_{2 \text{ th}}$			
2320	1888	1572	1278		2408					M_2			
1.2	1.3	1.7	2		1.1					c			
11	23	8	20		18					$n_{2 \text{ Eck}}$	1.29	2695	180.156
11	22	8	20		18					$n_{2 \text{ th}}$			
2679	2180									M_2			
1.1	1.2									c			
9	20									$n_{2 \text{ Eck}}$	0.88	2810	207.778
9	19									$n_{2 \text{ th}}$			
										M_2			
										c			
										$n_{2 \text{ Eck}}$	0.82	2695	236.622
										$n_{2 \text{ th}}$			

M ... [Nm]
n ... [min⁻¹]
J ... [kgcm²]

P ... [kW]
I ... [A]
i [-]
c [-]

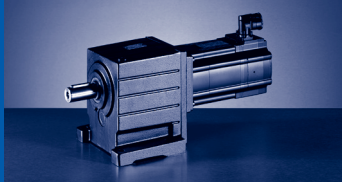

GST [Nm]

GST□□-□S (MCS)

$M_{2GN} \leq 2848 \text{ Nm}$

GST11-3S				09DC41	09FC38	09HC41	09LC41	12DC20	12DC41	12HC15	12HC30	12HC35
				...500	...500	...500	...500	...500	...500	...500	...500	...500
i	M_{2GN}	J_G	M_1	2.3	3.1	3.8	4.5	5.5	4.3	10	8	7.5
			n_1	4050	3750	4050	4050	1950	4050	1500	3000	3525
			I_{M230}	4.6	5	6.8	8.4	5.2	8.8	7.6	10.5	
			I_{M400}	2.3	2.5	3.4	4.2	2.6	4.5	3.8		5.7
			P_N	1	1.2	1.6	1.9	1.1	1.8	1.6	2.5	2.8
			J_M	1.13	1.53	1.93	2.83	4.12	4.12	7.42	7.42	7.42
252.167	2810	0.63	M_2	533	728	899	1069	1310	1020	2406	1919	1798
			c	4.6	3.5	2.8	2.4	2.1	2.5	1.2	1.5	1.5
			$n_{2 \text{ Eck}}$	16	15	16	16	8	16	6	12	14
			$n_{2 \text{ th}}$	16	15	16	16	8	16	6	12	14
268.889	2848	0.82	M_2	570	777	960	1141	1398	1090	2567	2047	1919
			c	4.4	3.3	2.6	2.2	2	2.3	1.1	1.4	1.4
			$n_{2 \text{ Eck}}$	15	14	15	15	7	15	6	11	13
			$n_{2 \text{ th}}$	15	14	15	15	7	15	6	11	13
326.333	2848	0.59	M_2	698	949	1171	1391	1703	1328		2491	2335
			c	3.6	2.7	2.2	1.8	1.7	1.9		1.1	1.2
			$n_{2 \text{ Eck}}$	12	12	12	12	6	12		9	11
			$n_{2 \text{ th}}$	12	11	12	12	6	12		9	11
363	2695	0.76	M_2	781	1060	1307	1552					
			c	3.1	2.3	1.9	1.6					
			$n_{2 \text{ Eck}}$	11	10	11	11					
			$n_{2 \text{ th}}$	11	10	11	11					
412.5	2848	0.55	M_2	889	1207	1487	1766					
			c	2.8	2.2	1.7	1.5					
			$n_{2 \text{ Eck}}$	10	9	10	10					
			$n_{2 \text{ th}}$	10	9	10	10					

$M \dots [\text{Nm}]$
 $n \dots [\text{min}^{-1}]$
 $J \dots [\text{kgcm}^2]$

$P \dots [\text{kW}]$
 $I \dots [\text{A}]$
 $i [-]$
 $c [-]$

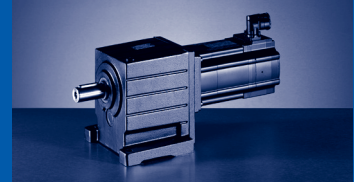

$M_{2GN} \leq 2848 \text{ Nm}$

12LC20	12LC41	14DC15	14DC36	14HC15	14HC32	14LC15	14LC32	14PC14	14PC32	GST11-3S			
...500	...500	...500	...500	...500	...500	...500	...500	...500	...500	M_1	J_G	M_{2GN}	i
13.5	11	9.2	7.5	16	14	23	17.2	30	21	n_1			
1950	4050	1500	3600	1500	3225	1500	3225	1350	3225	I_{M230}			
11.8										I_{M400}			
5.9	10.2	4.5	7.5	6.6	11.9	9.7	15	10.8	15.6	P_N			
2.8	4.7	1.45	2.8	2.5	4.7	3.6	5.8	4.2	7.1	J_M			
10.72	10.72	8.22	8.22	14.32	14.32	23.44	23.44	34.74	34.82	M_2			
										c			
										$n_{2 \text{ Eck}}$	0.63	2810	252.167
										$n_{2 \text{ th}}$			
										M_2			
										c			
										$n_{2 \text{ Eck}}$	0.82	2848	268.889
										$n_{2 \text{ th}}$			
										M_2			
										c			
										$n_{2 \text{ Eck}}$	0.59	2848	326.333
										$n_{2 \text{ th}}$			
										M_2			
										c			
										$n_{2 \text{ Eck}}$	0.76	2695	363
										$n_{2 \text{ th}}$			
										M_2			
										c			
										$n_{2 \text{ Eck}}$	0.55	2848	412.5
										$n_{2 \text{ th}}$			

M ... [Nm]
n ... [min^{-1}]
J ... [kgcm^2]

P ... [kW]
I ... [A]
i [-]
c [-]

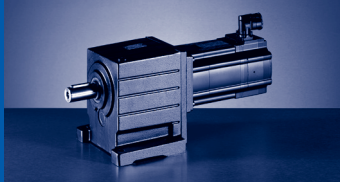

GST [Nm]

GST□□-□S (MCS)

$M_{2GN} \leq 3107 \text{ Nm}$

GST14-2S				19FC14	19FC30	19JC14	19JC30	19PC14	19PC30
				...500	...500	...500	...500	...500	...500
i	M_{2GN}	J_G	M_1	27	21	40	29	51	32
			n_1	1425	3000	1425	3000	1350	3000
			I_{M400}	8.6	14	12.3	18.5	14.3	19
			P_N	4	6.6	6	9.1	7.2	10
			J_M	65.12	65.04	105.04	105.12	160.12	160.04
5.2	1201	168	M_2			192		248	153
			c			6		4.7	5.9
			$n_{2 \text{ Eck}}$			274		260	577
			$n_{2 \text{ th}}$			274		260	328
5.714	1320	161	M_2			210		272	168
			c			6		4.7	5.9
			$n_{2 \text{ Eck}}$			249		236	525
			$n_{2 \text{ th}}$			249		236	299
6.286	1364	141	M_2			232		300	186
			c			5.6		4.4	5.6
			$n_{2 \text{ Eck}}$			227		215	477
			$n_{2 \text{ th}}$			227		215	276
8.027	1467	100	M_2			300	216	386	240
			c			4.7	5.2	3.7	4.7
			$n_{2 \text{ Eck}}$			178	374	168	374
			$n_{2 \text{ th}}$			178	247	168	242
8.8	2033	139	M_2			324		419	259
			c			6		4.7	5.9
			$n_{2 \text{ Eck}}$			162		153	341
			$n_{2 \text{ th}}$			162		153	194
9.841	1546	75.1	M_2	245		370	267	476	296
			c	6		4.1	4.4	3.2	4
			$n_{2 \text{ Eck}}$	145		145	305	137	305
			$n_{2 \text{ th}}$	145		145	219	137	214
11	2386	119	M_2			407		525	326
			c			5.6		4.4	5.6
			$n_{2 \text{ Eck}}$			130		123	273
			$n_{2 \text{ th}}$			130		123	158
12.362	2260	89	M_2			461	333	595	369
			c			4.7	5.2	3.7	4.7
			$n_{2 \text{ Eck}}$			115	243	109	243
			$n_{2 \text{ th}}$			115	161	109	157
14.048	2568	86.6	M_2			524	378	676	420
			c			4.7	5.2	3.7	4.7
			$n_{2 \text{ Eck}}$			101	214	96	214
			$n_{2 \text{ th}}$			101	141	96	138
15.156	2381	67.6	M_2	377		570	409	733	453
			c	6		4.1	5	3.2	4.6
			$n_{2 \text{ Eck}}$	94		94	198	89	198
			$n_{2 \text{ th}}$	94		94	146	89	143
17.222	2705	66	M_2	428		647	464	833	515
			c	6		4.1	5	3.2	4.6
			$n_{2 \text{ Eck}}$	83		83	174	78	174
			$n_{2 \text{ th}}$	83		83	128	78	126
20.044	2507	45.8	M_2	505	389	760	546	976	605
			c	4.8	5.5	3.2	4	2.5	3.6
			$n_{2 \text{ Eck}}$	71	150	71	150	67	150
			$n_{2 \text{ th}}$	71	110	71	110	67	110
22.778	2849	44.9	M_2	573	442	864	621	1109	688
			c	4.8	5.5	3.2	4	2.5	3.6
			$n_{2 \text{ Eck}}$	63	132	63	132	59	132
			$n_{2 \text{ th}}$	63	97	63	97	59	97

$M \dots$ [Nm]
 $n \dots$ [min^{-1}]
 $J \dots$ [kgcm^2]

$P \dots$ [kW]
 $I \dots$ [A]
 i [-]
 c [-]



$M_{2GN} \leq 3107 \text{ Nm}$

GST14-2S				19FC14	19FC30	19JC14	19JC30	19PC14	19PC30
				...500	...500	...500	...500	...500	...500
i	M_{2GN}	J_G	M_1	27	21	40	29	51	32
			n_1	1425	3000	1425	3000	1350	3000
			I_{M400}	8.6	14	12.3	18.5	14.3	19
			P_N	4	6.6	6	9.1	7.2	10
			J_M	65.12	65.04	105.04	105.12	160.12	160.04
24.567	2627	33.2	M_2	623	481	936	674	1201	746
			c	4.1	4.7	2.8	3.4	2.2	3.1
			$n_{2 \text{ Eck}}$	58	122	58	122	55	122
			$n_{2 \text{ th}}$	58	90	58	90	55	90
			M_2	708	547	1064	766	1365	848
27.917	2985	32.6	c	4.1	4.7	2.8	3.4	2.2	3.1
			$n_{2 \text{ Eck}}$	51	108	51	108	48	108
			$n_{2 \text{ th}}$	51	79	51	79	48	79
			M_2	826	639	1237	892	1585	987
			c	3.2	3.7	2.2	2.7	1.7	2.4
32.267	2701	21.5	$n_{2 \text{ Eck}}$	44	93	44	93	42	93
			$n_{2 \text{ th}}$	44	69	44	69	42	69
			M_2	939	726	1406	1014	1801	1122
			c	3.2	3.7	2.2	2.7	1.7	2.4
			$n_{2 \text{ Eck}}$	39	82	39	82	37	82
36.667	3069	21.2	$n_{2 \text{ th}}$	39	60	39	60	37	60
			M_2	1008	781	1507	1088	1929	1203
			c	2.7	3.1	1.8	2.2	1.4	2
			$n_{2 \text{ Eck}}$	36	77	36	77	35	77
			$n_{2 \text{ th}}$	36	56	36	56	34	56
39.16	2734	15.7	M_2	1146	884	1713	1233	2193	1364
			c	2.7	3.4	1.8	2.5	1.4	2.3
			$n_{2 \text{ Eck}}$	32	67	32	67	30	67
			$n_{2 \text{ th}}$	32	50	32	50	30	50

$M \dots$ [Nm]
 $n \dots$ [min^{-1}]
 $J \dots$ [kgcm^2]

$P \dots$ [kW]
 $I \dots$ [A]
 i [-]
 c [-]

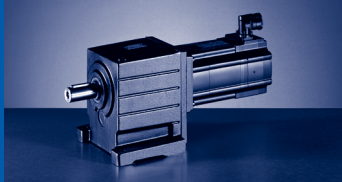

GST [Nm]

GST□□-□S (MCS)

$M_{2GN} \leq 5920 \text{ Nm}$

GST14-3S				12DC20	12DC41	12HC15	12HC30	12HC35	12LC20	12LC41	14DC15	14DC36	14HC15
				...500	...500	...500	...500	...500	...500	...500	...500	...500	...500
i	M_{2GN}	J_G	M_1	5.5	4.3	10	8	7.5	13.5	11	9.2	7.5	16
			n_1	1950	4050	1500	3000	3525	1950	4050	1500	3600	1500
			I_{M230}	5.2	8.8	7.6	10.5		11.8				
			I_{M400}	2.6	4.5	3.8		5.7	5.9	10.2	4.5	7.5	6.6
			P_N	1.1	1.8	1.6	2.5	2.8	2.8	4.7	1.45	2.8	2.5
			J_M	4.12	4.12	7.42	7.42	7.42	10.72	10.72	8.22	8.22	14.32
40.185	3459	24.4	M_2										585
			c										5.6
			$n_{2 \text{ Eck}}$										37
			$n_{2 \text{ th}}$										37
40.185	4476	24.4	M_2										
			c										
			$n_{2 \text{ Eck}}$										
			$n_{2 \text{ th}}$										
42.58	2052	18.3	M_2			390			534	433			
			c			5			3.7	4.2			
			$n_{2 \text{ Eck}}$			35			46	95			
			$n_{2 \text{ th}}$			35			46	84			
42.58	3211	18.3	M_2										624
			c										4.9
			$n_{2 \text{ Eck}}$										35
			$n_{2 \text{ th}}$										35
42.58	4262	18.3	M_2										
			c										
			$n_{2 \text{ Eck}}$										
			$n_{2 \text{ th}}$										
48.386	2332	18.1	M_2			443			606	492			
			c			5			3.7	4.2			
			$n_{2 \text{ Eck}}$			31			40	84			
			$n_{2 \text{ th}}$			31			40	74			
48.386	3649	18.1	M_2										709
			c										4.9
			$n_{2 \text{ Eck}}$										31
			$n_{2 \text{ th}}$										31
48.386	4843	18.1	M_2										
			c										
			$n_{2 \text{ Eck}}$										
			$n_{2 \text{ th}}$										
53.148	4574	20.5	M_2										773
			c										5.6
			$n_{2 \text{ Eck}}$										28
			$n_{2 \text{ th}}$										28
53.148	4779	20.5	M_2										
			c										
			$n_{2 \text{ Eck}}$										
			$n_{2 \text{ th}}$										
59.321	3840	13.2	M_2										876
			c										4.2
			$n_{2 \text{ Eck}}$										25
			$n_{2 \text{ th}}$										25
59.321	5267	13.2	M_2										
			c										
			$n_{2 \text{ Eck}}$										
			$n_{2 \text{ th}}$										
69.042	4470	11.5	M_2										1020
			c										4.2
			$n_{2 \text{ Eck}}$										22
			$n_{2 \text{ th}}$										22

$M \dots$ [Nm]
 $n \dots$ [min^{-1}]
 $J \dots$ [kgcm^2]

$P \dots$ [kW]
 $I \dots$ [A]
 $i \dots$ [-]
 $c \dots$ [-]

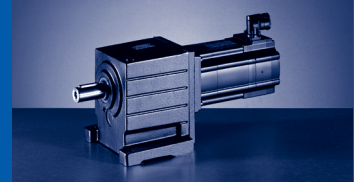

$M_{2GN} \leq 5920 \text{ Nm}$

14HC32	14LC15	14LC32	14PC14	14PC32	19FC14	19FC30	19JC14	19JC30	19PC14	19PC30	GST14-3S			
...500	...500	...500	...500	...500	...500	...500	...500	...500	...500	...500	M_1	J_G	M_{2GN}	i
14	23	17.2	30	21	27	21	40	29	51	32	n_1			
3225	1500	3225	1350	3225	1425	3000	1425	3000	1350	3000	I_{M230}			
											I_{M400}			
11.9	9.7	15	10.8	15.6	8.6	14	12.3	18.5	14.3	19	P_N			
4.7	3.6	5.8	4.2	7.1	4	6.6	6	9.1	7.2	10	J_M			
14.32	23.44	23.44	34.74	34.82	65.12	65.04	105.04	105.12	160.12	160.04	M_2			
511	856	636	1128	783							c			
5.7	3.9	4.6	3	3.8							$n_{2\text{ Eck}}$	24.4	3459	40.185
80	37	80	34	80							$n_{2\text{ th}}$			
80	37	80	34	77										
					1001	773	1505	1083	1932	1200	M_2			
					4.3	5	2.9	3.6	2.3	3.3	c			
					36	75	36	75	34	75	$n_{2\text{ Eck}}$	24.4	4476	40.185
					35	55	35	55	34	55	$n_{2\text{ th}}$			
											M_2			
											c	18.3	2052	42.58
											$n_{2\text{ Eck}}$			
											$n_{2\text{ th}}$			
543	912	674	1200	831							M_2			
5.5	3.4	4.5	2.6	3.7							c	18.3	3211	42.58
76	35	76	32	76							$n_{2\text{ Eck}}$			
76	35	76	32	76							$n_{2\text{ th}}$			
					1066	819	1600	1148	2052	1271	M_2			
					3.9	5	2.6	3.6	2.1	3.3	c	18.3	4262	42.58
					34	71	34	71	32	71	$n_{2\text{ Eck}}$			
					33	52	33	52	32	52	$n_{2\text{ th}}$			
											M_2			
											c	18.1	2332	48.386
											$n_{2\text{ Eck}}$			
											$n_{2\text{ th}}$			
617	1036	766	1364	944							M_2			
5.5	3.4	4.5	2.6	3.7							c	18.1	3649	48.386
67	31	67	28	67							$n_{2\text{ Eck}}$			
67	31	67	28	67							$n_{2\text{ th}}$			
					1211	931	1818	1304	2332	1445	M_2			
					3.9	5	2.6	3.6	2.1	3.3	c	18.1	4843	48.386
					30	62	30	62	28	62	$n_{2\text{ Eck}}$			
					29	46	29	46	28	46	$n_{2\text{ th}}$			
	1133	836	1492	1031							M_2			
	3.9	5.1	3	4.2							c	20.5	4574	53.148
	28	61	25	61							$n_{2\text{ Eck}}$			
	28	61	25	59							$n_{2\text{ th}}$			
					1336	1028	2003	1438	2568	1592	M_2			
					3.5	4.5	2.4	3.2	1.9	2.9	c	20.5	4779	53.148
					27	57	27	57	25	57	$n_{2\text{ Eck}}$			
					27	42	27	42	25	42	$n_{2\text{ th}}$			
763	1277	946	1678	1164							M_2			
4.7	3	3.9	2.3	3.2							c	13.2	3840	59.321
54	25	54	23	54							$n_{2\text{ Eck}}$			
54	25	54	23	54							$n_{2\text{ th}}$			
					1492	1148	2236	1606	2866	1778	M_2			
					3.4	4.4	2.3	3.2	1.8	2.9	c	13.2	5267	59.321
					24	51	24	51	23	51	$n_{2\text{ Eck}}$			
					24	37	24	37	23	37	$n_{2\text{ th}}$			
888	1487	1101	1953	1354							M_2			
4.7	3	3.9	2.3	3.2							c	11.5	4470	69.042
47	22	47	20	47							$n_{2\text{ Eck}}$			
47	22	47	20	47							$n_{2\text{ th}}$			

$M \dots$ [Nm]
 $n \dots$ [min^{-1}]
 $J \dots$ [kgcm^2]

$P \dots$ [kW]
 $I \dots$ [A]
 $i [-]$
 $c [-]$

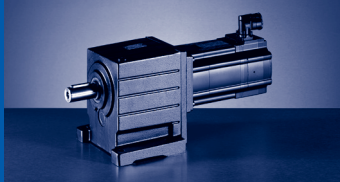

GST [Nm]

GST□□-□S (MCS)

$M_{2GN} \leq 5920 \text{ Nm}$

GST14-3S				12DC20	12DC41	12HC15	12HC30	12HC35	12LC20	12LC41	14DC15	14DC36	14HC15
				...500	...500	...500	...500	...500	...500	...500	...500	...500	...500
i	M_{2GN}	J_G	M_1	5.5	4.3	10	8	7.5	13.5	11	9.2	7.5	16
			n_1	1950	4050	1500	3000	3525	1950	4050	1500	3600	1500
			I_{M230}	5.2	8.8	7.6	10.5		11.8				
			I_{M400}	2.6	4.5	3.8		5.7	5.9	10.2	4.5	7.5	6.6
			P_N	1.1	1.8	1.6	2.5	2.8	2.8	4.7	1.45	2.8	2.5
			J_M	4.12	4.12	7.42	7.42	7.42	10.72	10.72	8.22	8.22	14.32
69.042	4917	11.5	M_2 c $n_{2 \text{ Eck}}$ $n_{2 \text{ th}}$										
78.457	5079	11.4	M_2 c $n_{2 \text{ Eck}}$ $n_{2 \text{ th}}$										1159 4.2 19 19
78.457	5587	11.4	M_2 c $n_{2 \text{ Eck}}$ $n_{2 \text{ th}}$										
93.541	3031	6.57	M_2 c $n_{2 \text{ Eck}}$ $n_{2 \text{ th}}$			872 3.4 16 16	691 4.2 32 32	647 4.3 38 38	1188 2.5 21 21	965 2.8 43 43			
93.541	4733	6.57	M_2 c $n_{2 \text{ Eck}}$ $n_{2 \text{ th}}$								782 5.8 16 16		1396 3.3 16 16
96.157	5882	10.4	M_2 c $n_{2 \text{ Eck}}$ $n_{2 \text{ th}}$										1424 4 16 16
106.296	3444	6.52	M_2 c $n_{2 \text{ Eck}}$ $n_{2 \text{ th}}$			990 3.4 14 14	785 4.2 28 28	736 4.3 33 33	1350 2.5 18 18	1097 2.8 38 38			
106.296	5378	6.52	M_2 c $n_{2 \text{ Eck}}$ $n_{2 \text{ th}}$								888 5.8 14 14		1586 3.3 14 14
130.278	4221	6	M_2 c $n_{2 \text{ Eck}}$ $n_{2 \text{ th}}$			1214 3.4 12 12	962 4.2 23 23	902 4.3 27 27	1654 2.5 15 15	1344 2.8 31 31			
130.278	5920	6	M_2 c $n_{2 \text{ Eck}}$ $n_{2 \text{ th}}$								1095 5.2 12 12	885 6 28 28	1951 3 12 12
139.211	3865	4.42	M_2 c $n_{2 \text{ Eck}}$ $n_{2 \text{ th}}$	699 5.3 14 14		1304 2.9 11 11	1035 3.6 22 22	970 3.7 25 25	1774 2.2 14 14	1442 2.4 29 29			
139.211	5736	4.42	M_2 c $n_{2 \text{ Eck}}$ $n_{2 \text{ th}}$								1177 4.7 11 11	952 5.4 26 26	2091 2.7 11 11
158.194	4392	4.4	M_2 c $n_{2 \text{ Eck}}$ $n_{2 \text{ th}}$	794 5.3 12 12		1482 2.9 10 9	1176 3.6 19 19	1102 3.7 22 22	2016 2.2 12 12	1639 2.4 26 26			

$M \dots$ [Nm]
 $n \dots$ [min^{-1}]
 $J \dots$ [kgcm^2]

$P \dots$ [kW]
 $I \dots$ [A]
 $i \dots$ [-]
 $c \dots$ [-]

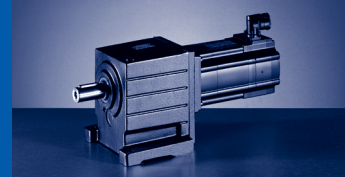

$M_{2GN} \leq 5920 \text{ Nm}$

14HC32	14LC15	14LC32	14PC14	14PC32	19FC14	19FC30	19JC14	19JC30	19PC14	19PC30	GST14-3S			
...S00	...S00	...S00	...S00	...S00	...S00	...S00	...S00	...S00	...S00	...S00	M_1	J_G	M_{2GN}	i
14	23	17.2	30	21	27	21	40	29	51	32	n_1			
3225	1500	3225	1350	3225	1425	3000	1425	3000	1350	3000	I_{M230}			
											I_{M400}			
11.9	9.7	15	10.8	15.6	8.6	14	12.3	18.5	14.3	19	P_N			
4.7	3.6	5.8	4.2	7.1	4	6.6	6	9.1	7.2	10	J_M			
14.32	23.44	23.44	34.74	34.82	65.12	65.04	105.04	105.12	160.12	160.04	M_2			
					1749	1349	2615	1882	3349	2082	c	11.5	4917	69.042
					2.8	3.6	1.9	2.6	1.5	2.3	$n_{2 \text{ Eck}}$			
					21	44	21	44	20	44	$n_{2 \text{ th}}$			
					21	32	21	32	20	32				
1009	1689	1251	2220	1539							M_2			
4.7	3	3.9	2.3	3.2							c	11.4	5079	78.457
41	19	41	17	41							$n_{2 \text{ Eck}}$			
41	19	41	17	41							$n_{2 \text{ th}}$			
					1987	1533	2972	2139	3805	2366	M_2			
					2.8	3.6	1.9	2.6	1.5	2.3	c	11.4	5587	78.457
					18	38	18	38	17	38	$n_{2 \text{ Eck}}$			
					18	28	18	28	17	28	$n_{2 \text{ th}}$			
											M_2			
											c	6.57	3031	93.541
											$n_{2 \text{ Eck}}$			
											$n_{2 \text{ th}}$			
1216	2028	1505	2660	1849							M_2			
3.7	2.3	3	1.8	2.5							c	6.57	4733	93.541
35	16	35	14	35							$n_{2 \text{ Eck}}$			
34	16	34	14	34							$n_{2 \text{ th}}$			
1240	2074	1537	2724	1890	2446	1888	3653	2631	4674	2910	M_2			
4.5	2.8	3.6	2.1	3	2.4	3.1	1.6	2.2	1.3	2	c	10.4	5882	96.157
34	16	34	14	34	15	31	15	31	14	31	$n_{2 \text{ Eck}}$			
34	16	34	14	34	15	23	15	23	14	23	$n_{2 \text{ th}}$			
											M_2			
											c	6.52	3444	106.296
											$n_{2 \text{ Eck}}$			
											$n_{2 \text{ th}}$			
1382	2305	1711	3023	2101							M_2			
3.7	2.3	3	1.8	2.5							c	6.52	5378	106.296
30	14	30	13	30							$n_{2 \text{ Eck}}$			
30	14	30	13	30							$n_{2 \text{ th}}$			
											M_2			
											c	6	4221	130.278
											$n_{2 \text{ Eck}}$			
											$n_{2 \text{ th}}$			
1701	2832	2103	3712	2581							M_2			
3.3	2.1	2.7	1.6	2.2							c	6	5920	130.278
25	12	25	10	25							$n_{2 \text{ Eck}}$			
25	12	25	10	25							$n_{2 \text{ th}}$			
											M_2			
											c	4.42	3865	139.211
											$n_{2 \text{ Eck}}$			
											$n_{2 \text{ th}}$			
1823	3032	2254	3973	2764							M_2			
3	1.9	2.5	1.4	2							c	4.42	5736	139.211
23	11	23	10	23							$n_{2 \text{ Eck}}$			
23	11	23	10	23							$n_{2 \text{ th}}$			
											M_2			
											c	4.4	4392	158.194
											$n_{2 \text{ Eck}}$			
											$n_{2 \text{ th}}$			

$M \dots$ [Nm]
 $n \dots$ [min^{-1}]
 $J \dots$ [kgcm^2]

$P \dots$ [kW]
 $I \dots$ [A]
 i [-]
 c [-]

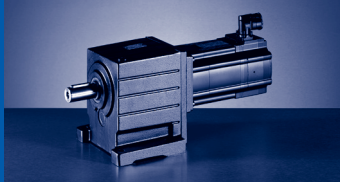

GST [Nm]

GST□□-□S (MCS)

$M_{2GN} \leq 5920 \text{ Nm}$

GST14-3S				12DC20	12DC41	12HC15	12HC30	12HC35	12LC20	12LC41	14DC15	14DC36	14HC15
				...500	...500	...500	...500	...500	...500	...500	...500	...500	...500
i	M_{2GN}	J_G	M_1	5.5	4.3	10	8	7.5	13.5	11	9.2	7.5	16
			n_1	1950	4050	1500	3000	3525	1950	4050	1500	3600	1500
			I_{M230}	5.2	8.8	7.6	10.5		11.8				
			I_{M400}	2.6	4.5	3.8		5.7	5.9	10.2	4.5	7.5	6.6
			P_N	1.1	1.8	1.6	2.5	2.8	2.8	4.7	1.45	2.8	2.5
			J_M	4.12	4.12	7.42	7.42	7.42	10.72	10.72	8.22	8.22	14.32
158.194	5920	4.4	M_2								1343	1087	2382
			c								4.3	4.9	2.5
			$n_{2 \text{ Eck}}$								10	23	10
			$n_{2 \text{ th}}$								9	23	9
171.111	5544	5.49	M_2			1594	1264	1184	2173	1765			
			c			3.4	4.2	4.3	2.5	2.8			
			$n_{2 \text{ Eck}}$			9	18	21	11	24			
			$n_{2 \text{ th}}$			9	18	21	11	24			
171.111	5920	5.49	M_2								1458	1181	2582
			c								3.9	4.5	2.3
			$n_{2 \text{ Eck}}$								9	21	9
			$n_{2 \text{ th}}$								9	21	9
204.722	4557	2.86	M_2	1040	807	1929	1534	1438	2621	2131			
			c	4.2	4.9	2.3	2.9	2.9	1.7	1.9			
			$n_{2 \text{ Eck}}$	10	20	7	15	17	10	20			
			$n_{2 \text{ th}}$	10	20	7	15	17	10	20			
204.722	5920	2.86	M_2								1757	1424	3101
			c								3.3	3.8	1.9
			$n_{2 \text{ Eck}}$								7	18	7
			$n_{2 \text{ th}}$								7	18	7
236.622	5267	2.65	M_2	1202	933	2230	1773	1662	3030	2464			
			c	4.2	4.9	2.3	2.9	2.9	1.7	1.9			
			$n_{2 \text{ Eck}}$	8	17	6	13	15	8	17			
			$n_{2 \text{ th}}$	8	17	6	13	15	8	17			
236.622	5779	2.65	M_2								2042	1657	3596
			c								2.8	3.2	1.6
			$n_{2 \text{ Eck}}$								6	15	6
			$n_{2 \text{ th}}$								6	15	6
248.458	4614	2.06	M_2	1271	988	2351	1871	1754	3191	2596			
			c	3.5	4.1	1.9	2.4	2.5	1.4	1.6			
			$n_{2 \text{ Eck}}$	8	16	6	12	14	8	16			
			$n_{2 \text{ th}}$	8	16	6	12	14	8	16			
248.458	5920	2.06	M_2								2145	1741	3777
			c								2.7	3.1	1.6
			$n_{2 \text{ Eck}}$								6	15	6
			$n_{2 \text{ th}}$								6	14	6
268.889	5920	2.65	M_2	1366	1060	2535	2015	1889	3443	2800	2327	1889	4093
			c	4.2	4.9	2.3	2.9	2.9	1.7	1.9	2.5	2.9	1.4
			$n_{2 \text{ Eck}}$	7	15	6	11	13	7	15	6	13	6
			$n_{2 \text{ th}}$	7	15	6	11	13	7	15	6	13	6
326.333	5920	1.92	M_2	1671	1299	3089	2459	2305	4192	3410	2837	2305	4980
			c	3.5	4	1.9	2.4	2.4	1.4	1.6	2.1	2.4	1.2
			$n_{2 \text{ Eck}}$	6	12	5	9	11	6	12	5	11	5
			$n_{2 \text{ th}}$	6	12	5	9	11	6	12	5	11	5
363	5401	2.45	M_2	1871	1456	3449	2748	2575	4676	3805			
			c	2.8	3.3	1.6	2	2	1.2	1.3			
			$n_{2 \text{ Eck}}$	5	11	4	8	10	5	11			
			$n_{2 \text{ th}}$	5	11	4	8	10	5	11			
412.5	5920	1.78	M_2	2129	1657	3921	3125	2929	5316	4326			
			c	2.7	3.2	1.5	1.9	1.9	1.1	1.2			
			$n_{2 \text{ Eck}}$	5	10	4	7	9	5	10			
			$n_{2 \text{ th}}$	5	10	4	7	9	5	10			

$M \dots [\text{Nm}]$
 $n \dots [\text{min}^{-1}]$
 $J \dots [\text{kgcm}^2]$

$P \dots [\text{kW}]$
 $I \dots [\text{A}]$
 $i \dots [-]$
 $c \dots [-]$

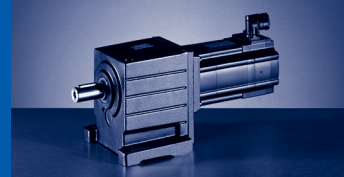

$M_{2GN} \leq 5920 \text{ Nm}$

14HC32	14LC15	14LC32	14PC14	14PC32	19FC14	19FC30	19JC14	19JC30	19PC14	19PC30	GST14-3S			
...S00	...S00	...S00	...S00	...S00	...S00	...S00	...S00	...S00	...S00	...S00	M_1	J_G	M_{2GN}	i
14	23	17.2	30	21	27	21	40	29	51	32	n_1			
3225	1500	3225	1350	3225	1425	3000	1425	3000	1350	3000	I_{M230}			
											I_{M400}			
11.9	9.7	15	10.8	15.6	8.6	14	12.3	18.5	14.3	19	P_N			
4.7	3.6	5.8	4.2	7.1	4	6.6	6	9.1	7.2	10	J_M			
14.32	23.44	23.44	34.74	34.82	65.12	65.04	105.04	105.12	160.12	160.04	M_2			
2078	3452	2567	4521	3148							c	4.4	5920	158.194
2.7	1.7	2.2	1.3	1.8							$n_{2 \text{ Eck}}$			
20	10	20	9	20							$n_{2 \text{ th}}$			
20	9	20	9	20							M_2			
											c	5.49	5544	171.111
											$n_{2 \text{ Eck}}$			
											$n_{2 \text{ th}}$			
2253	3739	2782	4895	3410							M_2			
2.5	1.6	2.1	1.2	1.7							c	5.49	5920	171.111
19	9	19	8	19							$n_{2 \text{ Eck}}$			
19	9	19	8	19							$n_{2 \text{ th}}$			
											M_2			
											c	2.86	4557	204.722
											$n_{2 \text{ Eck}}$			
											$n_{2 \text{ th}}$			
2707	4485	3340	5869	4091							M_2			
2.1	1.3	1.7	1	1.4							c	2.86	5920	204.722
16	7	16	7	16							$n_{2 \text{ Eck}}$			
16	7	16	7	16							$n_{2 \text{ th}}$			
											M_2			
											c	2.65	5267	236.622
											$n_{2 \text{ Eck}}$			
											$n_{2 \text{ th}}$			
3140	5195	3871		4739							M_2			
1.8	1.1	1.5		1.2							c	2.65	5779	236.622
14	6	14		14							$n_{2 \text{ Eck}}$			
14	6	14		14							$n_{2 \text{ th}}$			
											M_2			
											c	2.06	4614	248.458
											$n_{2 \text{ Eck}}$			
											$n_{2 \text{ th}}$			
3299	5456	4066		4978							M_2			
1.7	1.1	1.4		1.2							c	2.06	5920	248.458
13	6	13		13							$n_{2 \text{ Eck}}$			
13	6	13		13							$n_{2 \text{ th}}$			
3575	5910	4406		5392							M_2			
1.6	1	1.3		1.1							c	2.65	5920	268.889
12	6	12		12							$n_{2 \text{ Eck}}$			
12	6	12		12							$n_{2 \text{ th}}$			
4351		5360									M_2			
1.3		1.1									c	1.92	5920	326.333
10		10									$n_{2 \text{ Eck}}$			
10		10									$n_{2 \text{ th}}$			
											M_2			
											c	2.45	5401	363
											$n_{2 \text{ Eck}}$			
											$n_{2 \text{ th}}$			
											M_2			
											c	1.78	5920	412.5
											$n_{2 \text{ Eck}}$			
											$n_{2 \text{ th}}$			

$M \dots$ [Nm]
 $n \dots$ [min^{-1}]
 $J \dots$ [kgcm^2]

$P \dots$ [kW]
 $I \dots$ [A]
 i [-]
 c [-]

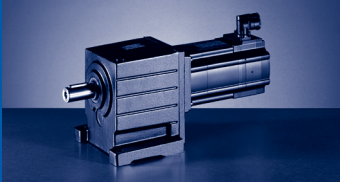

GST [Nm]

GST□□-□A (MCA)

$M_{2GN} \leq 25 \text{ Nm}$

GST04-1A				10IC40	13IC34	13IC41
				...500	...F10	...500
i	M_{2GN}	J_G	M_1			
			n_1	2	6.3	4
			I_{M400}	3950	3410	4050
			P_N	2.4	6	4.4
			J_M	0.8	2.2	1.7
			M_2	2.44	8.34	8.34
1.6	19	0.27	c	20	10	6
			n_2 Eck	5.1	1.5	2.2
			n_2 th	1023	2131	2531
				2439	1841	2159
2.048	23	0.19	M_2	4	13	8
			c	4.1	1.4	2
			n_2 Eck	1929	1665	1978
			n_2 th	1929	1623	1966
2.24	25	0.17	M_2	4	14	9
			c	4.1	1.4	2
			n_2 Eck	1763	1522	1808
			n_2 th	1763	1522	1808
2.857	25	0.13	M_2	6	18	11
			c	3.2	1.1	1.6
			n_2 Eck	1383	1194	1418
			n_2 th	1383	1194	1418
3.5	25	0.1	M_2	7		14
			c	2.6		1.3
			n_2 Eck	1129		1157
			n_2 th	1129		1157
4.4	25	0.07	M_2	9		
			c	2.1		
			n_2 Eck	898		
			n_2 th	898		
5.667	25	0.05	M_2	11		
			c	1.6		
			n_2 Eck	697		
			n_2 th	697		

M ... [Nm]
 n ... [min⁻¹]
 J ... [kgcm²]

P ... [kW]
 I ... [A]
 i [-]
 c [-]



$M_{2GN} \leq 71 \text{ Nm}$

GST04-2A				10IC40	13IC34	13IC41
				...500	...F10	...500
i	M_{2GN}	J_G	M_1			
			n_1	2	6.3	4
			I_{M400}	3950	3410	4050
			P_N	2.4	6	4.4
			J_M	0.8	2.2	1.7
			M_2	2.44	8.34	8.34
			c	6	18	11
2.956	39	0.34	n_2 Eck	4.9	1.7	2.5
			n_2 th	1337	1154	1370
				1218	923	1066
			M_2	6	20	13
			c	4.7	1.6	2.3
3.333	42	0.32	n_2 Eck	1185	1023	1215
			n_2 th	1070	795	935
			M_2	8	25	16
			c	4.1	1.4	2.1
4.053	45	0.31	n_2 Eck	975	841	999
			n_2 th	953	707	842
			M_2	9	28	18
			c	3.9	1.3	1.9
4.571	48	0.3	n_2 Eck	864	746	886
			n_2 th	837	612	736
			M_2	10	32	20
			c	3.6	1.2	1.8
5.187	50	0.22	n_2 Eck	762	657	781
			n_2 th	761	604	733
			M_2	11	36	23
			c	3.4	1.1	1.7
5.85	53	0.22	n_2 Eck	675	583	692
			n_2 th	675	523	630
			M_2	12	39	25
			c	3.2	1.1	1.6
6.4	55	0.19	n_2 Eck	617	533	633
			n_2 th	617	492	585
			M_2	13	43	27
			c	3	1	1.5
7.04	57	0.26	n_2 Eck	561	484	575
			n_2 th	520	359	421
			M_2	15		31
			c	2.7		1.4
8	59	0.26	n_2 Eck	494		506
			n_2 th	450		356
			M_2	17		35
			c	2.6		1.3
9.01	63	0.19	n_2 Eck	438		450
			n_2 th	438		359
			M_2	19		38
			c	2.5		1.2
9.856	65	0.17	n_2 Eck	401		411
			n_2 th	401		336
			M_2	22		
			c	2		
11.2	60	0.17	n_2 Eck	353		
			n_2 th	353		
			M_2	24		49
			c	2.1		1
12.571	69	0.13	n_2 Eck	314		322
			n_2 th	314		286

$M \dots$ [Nm]
 $n \dots$ [min^{-1}]
 $J \dots$ [kgcm^2]

$P \dots$ [kW]
 $I \dots$ [A]
 i [-]
 c [-]

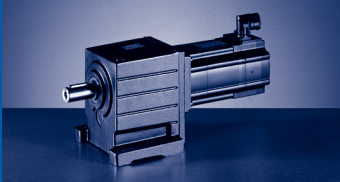

GST [Nm]

GST□□-□A (MCA)

$M_{2GN} \leq 71 \text{ Nm}$

GST04-2A				10IC40	13IC34	13IC41
				...500	...F10	...500
i	M_{2GN}	J_G	M_1			
			n_1	3950	3410	4050
			I_{M400}	2.4	6	4.4
			P_N	0.8	2.2	1.7
			J_M	2.44	8.34	8.34
14.286	61	0.12	M_2	28		
			c	1.6		
			$n_{2 \text{ Eck}}$	277		
			$n_{2 \text{ th}}$	277		
15.4	70	0.1	M_2	30		
			c	1.9		
			$n_{2 \text{ Eck}}$	257		
			$n_{2 \text{ th}}$	256		
17.5	62	0.1	M_2	34		
			c	1.5		
			$n_{2 \text{ Eck}}$	226		
			$n_{2 \text{ th}}$	226		
19.36	70	0.06	M_2	37		
			c	1.5		
			$n_{2 \text{ Eck}}$	204		
			$n_{2 \text{ th}}$	204		
22	62	0.06	M_2	43		
			c	1.2		
			$n_{2 \text{ Eck}}$	180		
			$n_{2 \text{ th}}$	180		
24.933	71	0.04	M_2	48		
			c	1.2		
			$n_{2 \text{ Eck}}$	158		
			$n_{2 \text{ th}}$	158		

M ... [Nm]
 n ... [min⁻¹]
 J ... [kgcm²]

P ... [kW]
 I ... [A]
 i [-]
 c [-]

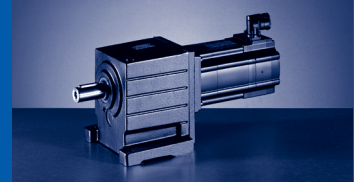

$M_{2GN} \leq 54 \text{ Nm}$

GST05-1A				10IC40	13IC34	13IC41	14LC16	14LC20	14LC35	14LC41
				...S00	...F10	...S00	...F10	...S00	...F10	...S00
i	M_{2GN}	J_G	M_1	2	6.3	4	12	6.7	10.8	5.4
			n_1	3950	3410	4050	1635	2000	3455	4100
			I_{M400}	2.4	6	4.4	4.8	3.3	9.1	5.8
			P_N	0.8	2.2	1.7	2.1	1.4	3.9	2.3
			J_M	2.44	8.34	8.34	19.32	19.24	19.24	19.24
1.6	45	0.76	M_2		10	6	19	10	17	8
			c		3.4	5.1	2.3	3.9	2	3.8
			$n_{2 \text{ Eck}}$		2131	2531	1022	1250	2159	2563
			$n_{2 \text{ th}}$		2056	2215	1022	1250	1847	2093
2.048	53	0.55	M_2		12	8	24	13	22	11
			c		3.1	4.7	2.1	3.5	1.8	3.5
			$n_{2 \text{ Eck}}$		1665	1978	799	977	1687	2002
			$n_{2 \text{ th}}$		1665	1856	798	977	1525	1753
2.24	53	0.48	M_2		14	9	26	14	24	12
			c		2.9	4.3	2	3.3	1.7	3.2
			$n_{2 \text{ Eck}}$		1522	1808	730	893	1542	1830
			$n_{2 \text{ th}}$		1522	1733	730	893	1397	1603
2.857	53	0.35	M_2		18	11	34	19	30	15
			c		2.3	3.4	1.5	2.6	1.3	2.5
			$n_{2 \text{ Eck}}$		1194	1418	572	700	1209	1435
			$n_{2 \text{ th}}$		1194	1418	572	700	1157	1257
3.5	54	0.27	M_2	7	22	14	41	23	37	18
			c	5.7	1.9	2.8	1.3	2.1	1.1	2.1
			$n_{2 \text{ Eck}}$	1129	974	1157	467	571	987	1171
			$n_{2 \text{ th}}$	1129	974	1157	467	571	987	1026
4.556	54	0.18	M_2	9	28	18				
			c	4.4	1.5	2.2				
			$n_{2 \text{ Eck}}$	867	749	889				
			$n_{2 \text{ th}}$	867	749	889				
5.667	54	0.13	M_2	11	35	22				
			c	3.5	1.2	1.7				
			$n_{2 \text{ Eck}}$	697	602	715				
			$n_{2 \text{ th}}$	697	602	715				
7.333	47	0.06	M_2	14						
			c	2.3						
			$n_{2 \text{ Eck}}$	539						
			$n_{2 \text{ th}}$	539						
8.9	42	0.06	M_2	17						
			c	1.7						
			$n_{2 \text{ Eck}}$	444						
			$n_{2 \text{ th}}$	444						

$M \dots$ [Nm]
 $n \dots$ [min^{-1}]
 $J \dots$ [kgcm^2]

$P \dots$ [kW]
 $I \dots$ [A]
 i [-]
 c [-]

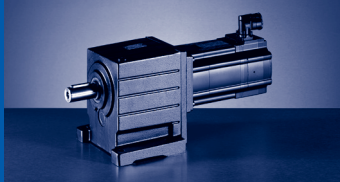

GST [Nm]

GST□□-□A (MCA)

$M_{2GN} \leq 165 \text{ Nm}$

GST05-2A				10IC40	13IC34	13IC41	14LC16	14LC20	14LC35	14LC41
				...500	...F10	...500	...F10	...500	...F10	...500
i	M_{2GN}	J_G	M_1	2	6.3	4	12	6.7	10.8	5.4
			n_1	3950	3410	4050	1635	2000	3455	4100
			I_{M400}	2.4	6	4.4	4.8	3.3	9.1	5.8
			P_N	0.8	2.2	1.7	2.1	1.4	3.9	2.3
			J_M	2.44	8.34	8.34	19.32	19.24	19.24	19.24
2.956	63	0.99	M_2		18	11	34	19	31	15
			c		2.7	4	1.8	3	1.5	2.9
			$n_{2 \text{ Eck}}$		1154	1370	553	677	1169	1387
			$n_{2 \text{ th}}$		899	975	553	677	735	917
3.333	78	0.94	M_2		20	12	38	21	35	17
			c		2.9	4.3	2	3.3	1.7	3.2
			$n_{2 \text{ Eck}}$		1023	1215	491	600	1037	1230
			$n_{2 \text{ th}}$		813	880	491	600	684	828
4.053	81	0.9	M_2		24	15	47	26	42	21
			c		2.5	3.7	1.7	2.8	1.5	2.7
			$n_{2 \text{ Eck}}$		841	999	403	493	852	1012
			$n_{2 \text{ th}}$		762	824	403	493	611	776
4.571	91	0.86	M_2		28	17	53	29	48	24
			c		2.5	3.7	1.7	2.8	1.4	2.7
			$n_{2 \text{ Eck}}$		746	886	358	438	756	897
			$n_{2 \text{ th}}$		675	730	358	438	541	688
5.187	90	0.64	M_2		31	20	60	33	54	27
			c		2.2	3.2	1.5	2.4	1.3	2.4
			$n_{2 \text{ Eck}}$		657	781	315	386	666	790
			$n_{2 \text{ th}}$		637	686	315	386	504	649
5.85	101	0.61	M_2		35	22	68	37	61	30
			c		2.2	3.2	1.5	2.4	1.3	2.4
			$n_{2 \text{ Eck}}$		583	692	280	342	591	701
			$n_{2 \text{ th}}$		565	608	279	342	447	575
6.4	105	0.53	M_2		39	24	74	41	67	33
			c		2	3	1.4	2.3	1.2	2.2
			$n_{2 \text{ Eck}}$		533	633	256	313	540	641
			$n_{2 \text{ th}}$		531	571	255	313	419	541
7.238	108	0.4	M_2	13	44	28	84	47	76	38
			c	5.6	1.9	2.8	1.3	2.1	1.1	2
			$n_{2 \text{ Eck}}$	546	471	560	226	276	477	567
			$n_{2 \text{ th}}$	546	471	560	226	276	419	496
8.163	115	0.39	M_2	15	50	31	95	53	86	42
			c	5.3	1.8	2.6	1.2	2	1	1.9
			$n_{2 \text{ Eck}}$	484	418	496	200	245	423	502
			$n_{2 \text{ th}}$	484	418	496	200	245	363	440
9.01	119	0.54	M_2	17	55	34	105	58		47
			c	4.9	1.6	2.4	1.1	1.8		1.8
			$n_{2 \text{ Eck}}$	438	379	450	182	222		455
			$n_{2 \text{ th}}$	426	328	376	181	222		344
10	124	0.3	M_2	19	61	38	116	65		52
			c	4.6	1.6	2.3	1	1.7		1.7
			$n_{2 \text{ Eck}}$	395	341	405	164	200		410
			$n_{2 \text{ th}}$	395	341	405	164	200		359
11.2	128	0.46	M_2	21	68	43		72		58
			c	4.3	1.4	2.1		1.6		1.6
			$n_{2 \text{ Eck}}$	353	305	362		179		366
			$n_{2 \text{ th}}$	346	258	306		179		269
13.016	137	0.18	M_2	24	79	50				
			c	3.9	1.3	2				
			$n_{2 \text{ Eck}}$	304	262	311				
			$n_{2 \text{ th}}$	303	262	311				

$M \dots$ [Nm]
 $n \dots$ [min^{-1}]
 $J \dots$ [kgcm^2]

$P \dots$ [kW]
 $I \dots$ [A]
 $i \dots$ [-]
 $c \dots$ [-]

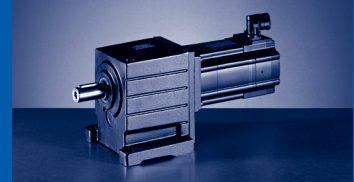

$M_{2GN} \leq 165 \text{ Nm}$

GST05-2A				10IC40	13IC34	13IC41	14LC16	14LC20	14LC35	14LC41
				...500	...F10	...500	...F10	...500	...F10	...500
i	M_{2GN}	J_G	M_1							
			n_1	2	6.3	4	12	6.7	10.8	5.4
			I_{M400}	3950	3410	4050	1635	2000	3455	4100
			P_N	2.4	6	4.4	4.8	3.3	9.1	5.8
			J_M	0.8	2.2	1.7	2.1	1.4	3.9	2.3
			M_2	2.44	8.34	8.34	19.32	19.24	19.24	19.24
			c	27	88	55				
14.356	140	0.13	n_2 Eck	3.6	1.2	1.8				
			n_2 th	275	238	282				
			n_2 th	275	238	282				
			M_2	30	99	62				
			c	3.9	1.3	1.9				
16.19	148	0.13	n_2 Eck	244	211	250				
			n_2 th	244	211	250				
			M_2	33	107	67		113		91
			c	3.4	1.2	1.7		1.3		1.3
17.5	142	0.27	n_2 Eck	226	195	231		114		234
			n_2 th	226	195	231		114		205
			M_2	38	122	77				
			c	3.4	1.1	1.7				
20.044	159	0.16	n_2 Eck	197	170	202				
			n_2 th	197	170	202				
			M_2	43		88				
			c	2.7		1.3				
22.778	144	0.16	n_2 Eck	173		178				
			n_2 th	173		178				
			M_2	48		96				
			c	2.8		1.4				
24.933	162	0.12	n_2 Eck	158		162				
			n_2 th	158		162				
			M_2	54		110				
			c	2.2		1.1				
28.333	147	0.12	n_2 Eck	139		143				
			n_2 th	139		143				
			M_2	62						
			c	2.2						
32.267	164	0.08	n_2 Eck	122						
			n_2 th	122						
			M_2	71						
			c	1.7						
36.667	148	0.08	n_2 Eck	108						
			n_2 th	108						
			M_2	75						
			c	1.8						
39.16	165	0.06	n_2 Eck	101						
			n_2 th	101						
			M_2	86						
			c	1.6						
44.5	149	0.06	n_2 Eck	89						
			n_2 th	89						

M ... [Nm]
n ... [min⁻¹]
J ... [kgcm²]

P ... [kW]
I ... [A]
i [-]
c [-]

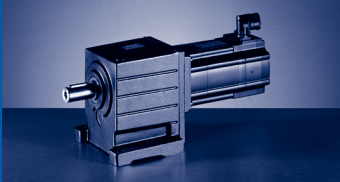

GST [Nm]

GST□□-□A (MCA)

$M_{2GN} \leq 167 \text{ Nm}$

GST05-3A				10IC40
				...500
i	M_{2GN}	J_G	M_1	
			n_1	2
			I_{M400}	3950
			P_N	-
			J_M	0.8
			M_2	2.44
			c	69
36.267	134	0.2	$n_{2 \text{ Eck}}$	1.6
			$n_{2 \text{ th}}$	109
			M_2	109
			c	88
46.259	145	0.14	$n_{2 \text{ Eck}}$	1.5
			$n_{2 \text{ th}}$	85
			M_2	85
			c	108
56.667	155	0.11	$n_{2 \text{ Eck}}$	1.3
			$n_{2 \text{ th}}$	70
			M_2	70
			c	121
63.467	146	0.19	$n_{2 \text{ Eck}}$	1.1
			$n_{2 \text{ th}}$	62
			M_2	62
			c	136
71.238	167	0.07	$n_{2 \text{ Eck}}$	1.1
			$n_{2 \text{ th}}$	56
				55

M ... [Nm]
 n ... [min^{-1}]
 J ... [kgcm^2]

P ... [kW]
 I ... [A]
 i [-]
 c [-]

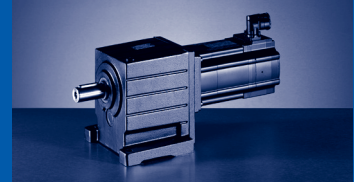

$M_{2GN} \leq 105 \text{ Nm}$

GST06-1A				10IC40	13IC34	13IC41	14LC16	14LC20	14LC35	14LC41	17NC17	17NC23	17NC35	17NC41
				...S00	...F10	...S00	...F10	...S00	...F10	...S00	...F10	...S00	...F10	...S00
i	M_{2GN}	J_G	M_1	2	6.3	4	12	6.7	10.8	5.4	21.5	10.8	19	9.5
			n_1	3950	3410	4050	1635	2000	3455	4100	1680	2300	3480	4110
			I_{M400}	2.4	6	4.4	4.8	3.3	9.1	5.8	8.5	5.5	15.8	10.2
			P_N	0.8	2.2	1.7	2.1	1.4	3.9	2.3	3.8	2.6	6.9	4.1
			J_M	2.44	8.34	8.34	19.32	19.24	19.24	19.24	36.04	36.04	36.04	36.04
1.6	61	2.01	M_2				18	10	17	8	34	17	30	15
			c				3.2	5.3	2.7	5.2	1.8	3.1	1.6	2.9
			$n_{2 \text{ Eck}}$				1022	1250	2159	2563	1050	1438	2175	2569
			$n_{2 \text{ th}}$				1022	1250	1635	1862	1050	1438	1325	1660
2.048	72	1.46	M_2		12		24	13	21	10	43	21	38	19
			c		4.3		2.9	4.9	2.5	4.8	1.6	2.9	1.4	2.7
			$n_{2 \text{ Eck}}$		1665		799	977	1687	2002	821	1123	1700	2007
			$n_{2 \text{ th}}$		1628		798	977	1459	1657	820	1123	1148	1481
2.24	79	1.27	M_2		13		26	14	23	11	47	23	42	21
			c		4.3		2.9	4.8	2.5	4.7	1.6	2.9	1.4	2.7
			$n_{2 \text{ Eck}}$		1522		730	893	1542	1830	750	1027	1554	1835
			$n_{2 \text{ th}}$		1522		730	893	1379	1561	750	1027	1093	1389
2.857	92	0.97	M_2		17	11	33	18	30	15	60	30	53	26
			c		4	5.9	2.7	4.5	2.3	4.4	1.5	2.6	1.3	2.5
			$n_{2 \text{ Eck}}$		1194	1418	572	700	1209	1435	588	805	1218	1439
			$n_{2 \text{ th}}$		1194	1395	572	700	1184	1257	588	805	944	1089
3.5	105	0.74	M_2		21	13	41	22	37	18	74	37	65	32
			c		3.7	5.5	2.5	4.1	2.1	4	1.4	2.4	1.2	2.3
			$n_{2 \text{ Eck}}$		974	1157	467	571	987	1171	480	657	994	1174
			$n_{2 \text{ th}}$		974	1157	467	571	987	1026	480	657	861	889
4.556	105	0.48	M_2		28	17	53	29	48	24				
			c		2.8	4.2	1.9	3.2	1.6	3.1				
			$n_{2 \text{ Eck}}$		749	889	359	439	758	900				
			$n_{2 \text{ th}}$		749	889	359	439	758	788				
5.667	82	0.36	M_2	11										
			c	5.3										
			$n_{2 \text{ Eck}}$	697										
			$n_{2 \text{ th}}$	697										
5.667	105	0.36	M_2		35	22	67	37	60	30				
			c		2.3	3.4	1.5	2.6	1.3	2.5				
			$n_{2 \text{ Eck}}$		602	715	289	353	610	724				
			$n_{2 \text{ th}}$		602	715	289	353	610	634				
7.333	95	0.23	M_2	14										
			c	4.8										
			$n_{2 \text{ Eck}}$	539										
			$n_{2 \text{ th}}$	539										
7.333	100	0.23	M_2		45	28								
			c		1.7	2.5								
			$n_{2 \text{ Eck}}$		465	552								
			$n_{2 \text{ th}}$		465	552								
8.9	85	0.17	M_2	17	55	35								
			c	3.5	1.2	1.8								
			$n_{2 \text{ Eck}}$	444	383	455								
			$n_{2 \text{ th}}$	444	383	455								
11.25	63	0.11	M_2	22										
			c	2.1										
			$n_{2 \text{ Eck}}$	351										
			$n_{2 \text{ th}}$	351										

$M \dots$ [Nm]
 $n \dots$ [min^{-1}]
 $J \dots$ [kgcm^2]

$P \dots$ [kW]
 $I \dots$ [A]
 i [-]
 c [-]

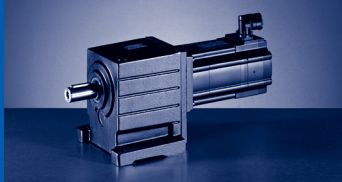

GST [Nm]

GST□□-□A (MCA)

$M_{2GN} \leq 368 \text{ Nm}$

GST06-2A				10IC40	13IC34	13IC41	14LC16	14LC20	14LC35	14LC41	17NC17	17NC23	17NC35	17NC41	
				...S00	...F10	...S00	...F10	...S00	...F10	...S00	...F10	...S00	...F10	...S00	...F10
i	M_{2GN}	J_G	M_1	2	6.3	4	12	6.7	10.8	5.4	21.5	10.8	19	9.5	
			n_1	3950	3410	4050	1635	2000	3455	4100	1680	2300	3480	4110	
			I_{M400}	2.4	6	4.4	4.8	3.3	9.1	5.8	8.5	5.5	15.8	10.2	
			P_N	0.8	2.2	1.7	2.1	1.4	3.9	2.3	3.8	2.6	6.9	4.1	
			J_M	2.44	8.34	8.34	19.32	19.24	19.24	19.24	36.04	36.04	36.04	36.04	
3.033	166	2.72	M_2				34		31		62	31	55	27	
			c				4.6		4		2.5	4.5	2.3	4.3	
			$n_{2 \text{ Eck}}$				539		1139		554		758	1147	1355
			$n_{2 \text{ th}}$				539		803		554		758	708	815
3.333	174	2.61	M_2				37		34		69	34	61	30	
			c				4.4		3.8		2.4	4.3	2.1	4.1	
			$n_{2 \text{ Eck}}$				491		1037		504		690	1044	1233
			$n_{2 \text{ th}}$				491		724		504		690	637	734
4.16	191	2.51	M_2				47		43		86	42	76	37	
			c				3.8		3.3		2.1	3.8	1.9	3.6	
			$n_{2 \text{ Eck}}$				393		831		404		553	837	988
			$n_{2 \text{ th}}$				393		656		404		553	569	665
4.571	200	2.41	M_2				52		47	23	94	47	84	41	
			c				3.7		3.2	6	2	3.6	1.8	3.4	
			$n_{2 \text{ Eck}}$				358		756	897	368	503	761	899	
			$n_{2 \text{ th}}$				358		590	670	368	503	503	599	
5.324	207	1.76	M_2		31		61	33	55	27	110	55	98	48	
			c		4.9		3.3	5.4	2.8	5.3	1.8	3.2	1.6	3	
			$n_{2 \text{ Eck}}$		641		307	376	649	770	316	432	654	772	
			$n_{2 \text{ th}}$		640		307	376	574	651	316	432	470	583	
5.85	222	1.71	M_2		34		67	36	60	29	121	60	107	53	
			c		4.7		3.2	5.3	2.7	5.2	1.8	3.1	1.6	2.9	
			$n_{2 \text{ Eck}}$		583		280	342	591	701	287	393	595	703	
			$n_{2 \text{ th}}$		579		279	342	520	589	287	393	421	527	
6.4	229	1.47	M_2		38		73	40	66	32	133	66	117	58	
			c		4.5		3	5	2.6	4.9	1.7	3	1.5	2.8	
			$n_{2 \text{ Eck}}$		533		256	313	540	641	263	359	544	642	
			$n_{2 \text{ th}}$		533		255	313	487	550	263	359	390	486	
7.04	236	2.07	M_2				80	44	73	36	146	72	129	64	
			c				2.8	4.7	2.4	4.6	1.6	2.8	1.4	2.6	
			$n_{2 \text{ Eck}}$				232	284	491	582	239	327	494	584	
			$n_{2 \text{ th}}$				232	284	362	414	239	327	283	368	
8.163	252	1.06	M_2		48	30	94	51	84	41	170	84	150	74	
			c		3.8	5.7	2.6	4.3	2.2	4.2	1.4	2.6	1.3	2.4	
			$n_{2 \text{ Eck}}$		418	496	200	245	423	502	206	282	426	504	
			$n_{2 \text{ th}}$		418	486	200	245	412	440	206	282	326	381	
9.01	261	1.5	M_2		54	33	103	57	93	46	187	93	166	82	
			c		3.6	5.4	2.4	4.1	2.1	4	1.3	2.4	1.2	2.3	
			$n_{2 \text{ Eck}}$		379	450	182	222	384	455	187	255	386	456	
			$n_{2 \text{ th}}$		357	385	181	222	318	364	186	255	237	323	
10	269	0.82	M_2		60	37	115	63	104	51	208	103	184	91	
			c		3.4	5	2.3	3.8	2	3.7	1.2	2.2	1.1	2.1	
			$n_{2 \text{ Eck}}$		341	405	164	200	346	410	168	230	348	411	
			$n_{2 \text{ th}}$		341	405	164	200	346	359	168	230	289	311	
11.2	280	1.26	M_2		67	42	129	71	116	57	233	116	206	102	
			c		3.1	4.6	2.1	3.5	1.8	3.4	1.2	2.1	1	1.9	
			$n_{2 \text{ Eck}}$		305	362	146	179	309	366	150	205	311	367	
			$n_{2 \text{ th}}$		289	311	146	179	250	294	150	205	188	260	
12.571	295	0.96	M_2		75	47	145	80	131	64	262	130		115	
			c		2.9	4.3	2	3.3	1.7	3.2	1.1	1.9		1.8	
			$n_{2 \text{ Eck}}$		271	322	130	159	275	326	134	183		327	
			$n_{2 \text{ th}}$		271	301	130	159	242	286	134	183		247	

$M \dots$ [Nm]
 $n \dots$ [min^{-1}]
 $J \dots$ [kgcm^2]

$P \dots$ [kW]
 $I \dots$ [A]
 i [-]
 c [-]



$M_{2GN} \leq 368 \text{ Nm}$

GST06-2A				10IC40	13IC34	13IC41	14LC16	14LC20	14LC35	14LC41	17NC17	17NC23	17NC35	17NC41
				...S00	...F10	...S00	...F10	...S00	...F10	...S00	...F10	...S00	...F10	...S00
i	M_{2GN}	J_G	M_1	2	6.3	4	12	6.7	10.8	5.4	21.5	10.8	19	9.5
			n_1	3950	3410	4050	1635	2000	3455	4100	1680	2300	3480	4110
			I_{M400}	2.4	6	4.4	4.8	3.3	9.1	5.8	8.5	5.5	15.8	10.2
			P_N	0.8	2.2	1.7	2.1	1.4	3.9	2.3	3.8	2.6	6.9	4.1
			J_M	2.44	8.34	8.34	19.32	19.24	19.24	19.24	36.04	36.04	36.04	36.04
14.286	307	0.93	M_2		86	54	165	91	149	73		148		131
			c		2.7	4	1.8	3	1.6	2.9		1.8		1.7
			$n_{2 \text{ Eck}}$		239	284	115	140	242	287		161		288
			$n_{2 \text{ th}}$		239	261	114	140	204	248		161		211
15.4	318	0.75	M_2		92	58	178	98	160	79		160		141
			c		2.9	4.3	1.8	3.2	1.7	3.2		1.9		1.8
			$n_{2 \text{ Eck}}$		221	263	106	130	224	266		149		267
			$n_{2 \text{ th}}$		221	263	106	130	224	233		149		202
17.5	313	0.73	M_2		105	66	203	112	182	90		182		160
			c		2.5	3.8	1.5	2.8	1.5	2.8		1.7		1.6
			$n_{2 \text{ Eck}}$		195	231	93	114	197	234		131		235
			$n_{2 \text{ th}}$		195	231	93	114	189	205		131		178
20.044	350	0.46	M_2		121	76	232	128	209	103				
			c		2.5	3.7	1.5	2.7	1.4	2.7				
			$n_{2 \text{ Eck}}$		170	202	82	100	172	205				
			$n_{2 \text{ th}}$		170	202	82	100	172	179				
22.778	315	0.45	M_2	42	138	87	265	146	238	118				
			c	5.9	2	2.9	1.2	2.1	1.1	2.2				
			$n_{2 \text{ Eck}}$	173	150	178	72	88	152	180				
			$n_{2 \text{ th}}$	173	150	178	72	88	152	158				
24.933	360	0.33	M_2		151	95	290	160	261	129				
			c		2	3	1.2	2.2	1.2	2.2				
			$n_{2 \text{ Eck}}$		137	162	66	80	139	164				
			$n_{2 \text{ th}}$		137	162	66	80	139	144				
28.333	317	0.33	M_2	53	172	108		183		147				
			c	4.7	1.6	2.4		1.7		1.7				
			$n_{2 \text{ Eck}}$	139	120	143		71		145				
			$n_{2 \text{ th}}$	139	120	143		71		127				
32.267	363	0.22	M_2	60	196	123								
			c	4.8	1.6	2.4								
			$n_{2 \text{ Eck}}$	122	106	126								
			$n_{2 \text{ th}}$	122	106	126								
36.667	322	0.22	M_2	69	224	141								
			c	3.7	1.2	1.9								
			$n_{2 \text{ Eck}}$	108	93	111								
			$n_{2 \text{ th}}$	108	93	110								
39.16	368	0.16	M_2	74	239	150								
			c	4	1.3	2								
			$n_{2 \text{ Eck}}$	101	87	103								
			$n_{2 \text{ th}}$	101	87	103								
44.5	325	0.16	M_2	84	272	171								
			c	3.4	1.2	1.7								
			$n_{2 \text{ Eck}}$	89	77	91								
			$n_{2 \text{ th}}$	89	77	91								
49.5	278	0.11	M_2	94										
			c	2.6										
			$n_{2 \text{ Eck}}$	80										
			$n_{2 \text{ th}}$	80										
56.25	316	0.11	M_2	107										
			c	2.6										
			$n_{2 \text{ Eck}}$	70										
			$n_{2 \text{ th}}$	70										

$M \dots$ [Nm]
 $n \dots$ [min^{-1}]
 $J \dots$ [kgcm^2]

$P \dots$ [kW]
 $I \dots$ [A]
 i [-]
 c [-]

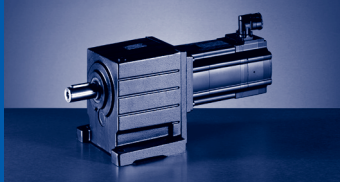

GST [Nm]

GST□□-□A (MCA)

$M_{2GN} \leq 375 \text{ Nm}$

GST06-3A				10IC40	13IC34	13IC41
				...500	...F10	...500
i	M_{2GN}	J_G	M_1			
			n_1	2	6.3	4
			I_{M400}	3950	3410	4050
			P_N	2.4	6	4.4
			J_M	0.8	2.2	1.7
			M_2	2.44	8.34	8.34
39.2	321	0.36	c	73	236	149
			n_2 Eck	3.5	1.2	1.8
			n_2 th	101	87	103
				101	87	103
44	335	0.2	M_2	82	264	167
			c	3.6	1.2	1.8
			n_2 Eck	90	78	92
			n_2 th	90	78	92
51.022	325	0.32	M_2	95	307	194
			c	3	1	1.5
			n_2 Eck	77	67	79
			n_2 th	77	67	79
53.9	349	0.18	M_2	101	324	205
			c	3.1	1	1.5
			n_2 Eck	73	63	75
			n_2 th	73	63	75
67.76	365	0.11	M_2	127		
			c	2.6		
			n_2 Eck	58		
			n_2 th	58		
70.156	359	0.16	M_2	132		268
			c	2.4		1.2
			n_2 Eck	56		58
			n_2 th	56		58
80.952	332	0.2	M_2	153		
			c	2		
			n_2 Eck	49		
			n_2 th	49		
87.267	370	0.15	M_2	165		334
			c	2		1
			n_2 Eck	45		46
			n_2 th	45		46
99.167	336	0.15	M_2	188		
			c	1.6		
			n_2 Eck	40		
			n_2 th	40		
109.707	375	0.1	M_2	208		
			c	1.6		
			n_2 Eck	36		
			n_2 th	36		
124.667	339	0.1	M_2	238		
			c	1.3		
			n_2 Eck	32		
			n_2 th	32		
141.289	375	0.06	M_2	269		
			c	1.3		
			n_2 Eck	28		
			n_2 th	28		
160.556	342	0.06	M_2	307		
			c	1		
			n_2 Eck	25		
			n_2 th	25		

$M \dots$ [Nm]
 $n \dots$ [min^{-1}]
 $J \dots$ [kgcm^2]

$P \dots$ [kW]
 $I \dots$ [A]
 i [-]
 c [-]

GST [Nm]
GST□□-□A (MCA)

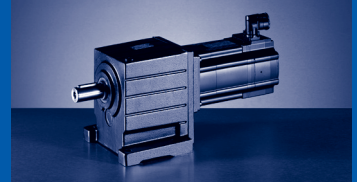

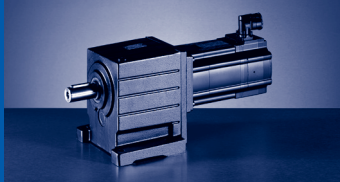

GST [Nm]

GST□□-□A (MCA)

$M_{2GN} \leq 196 \text{ Nm}$

GST07-1A				10IC40	13IC34	13IC41	14LC16	14LC20	14LC35	14LC41	17NC17	17NC23	
				...500	...F10	...S00	...F10	...S00	...F10	...S00	...F10	...S00	
i	M_{2GN}	J_G	M_1	2	6.3	4	12	6.7	10.8	5.4	21.5	10.8	
			n_1	3950	3410	4050	1635	2000	3455	4100	1680	2300	
			I_{M400}	2.4	6	4.4	4.8	3.3	9.1	5.8	8.5	5.5	
			P_N	0.8	2.2	1.7	2.1	1.4	3.9	2.3	3.8	2.6	
			J_M	2.44	8.34	8.34	19.32	19.24	19.24	19.24	36.04	36.04	
1.625	106	6.12	M_2								34	17	
			c								3	5.3	
			$n_{2 \text{ Eck}}$									1034	1415
			$n_{2 \text{ th}}$									1034	1415
2	124	4.78	M_2				23		21		42	20	
			c				5.1		4.4		2.8	5.1	
			$n_{2 \text{ Eck}}$				818		1728		840	1150	
			$n_{2 \text{ th}}$				818		1386		840	1150	
2.24	135	4.02	M_2				25		23		47	23	
			c				4.9		4.3		2.7	4.9	
			$n_{2 \text{ Eck}}$				730		1542		750	1027	
			$n_{2 \text{ th}}$				730		1280		750	1027	
2.857	118	2.69	M_2		17								
			c		5.1								
			$n_{2 \text{ Eck}}$		1194								
			$n_{2 \text{ th}}$		1194								
2.857	159	2.69	M_2				33		29		60	29	
			c				4.6		4		2.5	4.5	
			$n_{2 \text{ Eck}}$				572		1209		588	805	
			$n_{2 \text{ th}}$				572		1154		588	805	
3.5	172	2.15	M_2				40		36		73	36	
			c				4		3.5		2.2	4	
			$n_{2 \text{ Eck}}$				467		987		480	657	
			$n_{2 \text{ th}}$				467		987		480	657	
4.556	150	1.37	M_2		27	17							
			c		4	6							
			$n_{2 \text{ Eck}}$		749	889							
			$n_{2 \text{ th}}$		749	889							
4.556	186	1.37	M_2				53	29	48	23	96	47	
			c				3.4	5.6	2.9	5.5	1.9	3.3	
			$n_{2 \text{ Eck}}$				359	439	758	900	369	505	
			$n_{2 \text{ th}}$				359	439	758	788	369	505	
5.583	156	1.05	M_2		34	21							
			c		3.4	5.1							
			$n_{2 \text{ Eck}}$		611	725							
			$n_{2 \text{ th}}$		611	725							
5.583	196	1.05	M_2				65	35	58	29	118	58	
			c				2.9	4.8	2.5	4.7	1.6	2.9	
			$n_{2 \text{ Eck}}$				293	358	619	734	301	412	
			$n_{2 \text{ th}}$				293	358	619	643	301	412	
7.333	107	0.66	M_2	14									
			c	5.3									
			$n_{2 \text{ Eck}}$	539									
			$n_{2 \text{ th}}$	539									
7.333	161	0.66	M_2		45	28							
			c		2.7	4							
			$n_{2 \text{ Eck}}$		465	552							
			$n_{2 \text{ th}}$		465	552							
7.333	196	0.66	M_2				86	47	77	38			
			c				2.2	3.7	1.9	3.6			
			$n_{2 \text{ Eck}}$				223	273	471	559			
			$n_{2 \text{ th}}$				223	273	471	490			

$M \dots$ [Nm]
 $n \dots$ [min^{-1}]
 $J \dots$ [kgcm^2]

$P \dots$ [kW]
 $I \dots$ [A]
 $i \dots$ [-]
 $c \dots$ [-]

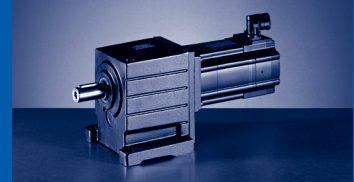

$M_{2GN} \leq 196 \text{ Nm}$

17NC35	17NC41	19SC17	19SC23	19SC35	19SC42	21XC17	21XC25	21XC42	GST07-1A			
...F10	...S00	...F10	...S00	...F10	...S00	...F10	...S00	...S00				
19	9.5	36.3	16.3	36	12	61.4	24.6	17	M_1	J_G	M_{2GN}	i
3480	4110	1700	2340	3510	4150	1710	2490	4160	n_1			
15.8	10.2	13.9	8.2	28.7	14	22.5	13.5	19.8	I_{M400}			
6.9	4.1	6.4	4	13.2	5.2	11	6.4	7.4	P_N			
36.04	36.04	72.12	72.12	72.04	72.12	180.04	180.04	180.04	J_M			
30	15	58	25	57	19	98	39	27	M_2			
2.6	5	1.8	3.5	1.4	3.9	1	2.3	2.8	c	6.12	106	1.625
2142	2529	1046	1440	2160	2554	1052	1532	2560	$n_{2\text{ Eck}}$			
1347	1547	1046	1437	1027	1473	887	1239	1239	$n_{2\text{ th}}$			
37	18	71	31	71	23		48	33	M_2			
2.5	4.7	1.7	3.3	1.3	3.7		2.2	2.6	c	4.78	124	2
1740	2055	850	1170	1755	2075		1245	2080	$n_{2\text{ Eck}}$			
1225	1406	850	1170	915	1224		1007	1007	$n_{2\text{ th}}$			
41	20	80	35	79	26		54	37	M_2			
2.4	4.6	1.6	3.2	1.3	3.6		2.1	2.6	c	4.02	135	2.24
1554	1835	759	1045	1567	1853		1112	1857	$n_{2\text{ Eck}}$			
1136	1298	759	1045	854	1093		899	899	$n_{2\text{ th}}$			
									M_2			
									c	2.69	118	2.857
									$n_{2\text{ Eck}}$			
									$n_{2\text{ th}}$			
53	26	102	45	101	33				M_2			
2.2	4.2	1.5	3	1.2	3.4				c	2.69	159	2.857
1218	1439	595	819	1229	1453				$n_{2\text{ Eck}}$			
1027	1089	595	819	753	857				$n_{2\text{ th}}$			
65	32	125	55	124	41				M_2			
2	3.8	1.3	2.6	1	3				c	2.15	172	3.5
994	1174	486	669	1003	1186				$n_{2\text{ Eck}}$			
889	889	486	669	663	700				$n_{2\text{ th}}$			
									M_2			
									c	1.37	150	4.556
									$n_{2\text{ Eck}}$			
									$n_{2\text{ th}}$			
85	42								M_2			
1.7	3.1								c	1.37	186	4.556
764	902								$n_{2\text{ Eck}}$			
683	683								$n_{2\text{ th}}$			
									M_2			
									c	1.05	156	5.583
									$n_{2\text{ Eck}}$			
									$n_{2\text{ th}}$			
104	51								M_2			
1.4	2.7								c	1.05	196	5.583
623	736								$n_{2\text{ Eck}}$			
557	557								$n_{2\text{ th}}$			
									M_2			
									c	0.66	107	7.333
									$n_{2\text{ Eck}}$			
									$n_{2\text{ th}}$			
									M_2			
									c	0.66	161	7.333
									$n_{2\text{ Eck}}$			
									$n_{2\text{ th}}$			
									M_2			
									c	0.66	196	7.333
									$n_{2\text{ Eck}}$			
									$n_{2\text{ th}}$			

M ... [Nm]
n ... [min⁻¹]
J ... [kgcm²]

P ... [kW]
I ... [A]
i [-]
c [-]

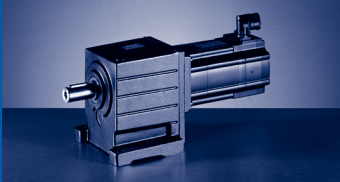

GST [Nm]

GST□□-□A (MCA)

$M_{2GN} \leq 196 \text{ Nm}$

GST07-1A				10IC40	13IC34	13IC41	14LC16	14LC20	14LC35	14LC41	17NC17	17NC23
				...S00	...F10	...S00	...F10	...S00	...F10	...S00	...F10	...S00
i	M_{2GN}	J_G	M_1	2	6.3	4	12	6.7	10.8	5.4	21.5	10.8
			n_1	3950	3410	4050	1635	2000	3455	4100	1680	2300
			I_{M400}	2.4	6	4.4	4.8	3.3	9.1	5.8	8.5	5.5
			P_N	0.8	2.2	1.7	2.1	1.4	3.9	2.3	3.8	2.6
			J_M	2.44	8.34	8.34	19.32	19.24	19.24	19.24	36.04	36.04
8.9	113	0.49	M_2	17								
			c	4.7								
			$n_{2 \text{ Eck}}$	444								
			$n_{2 \text{ th}}$	444								
8.9	164	0.49	M_2		55	34						
			c		2.3	3.4						
			$n_{2 \text{ Eck}}$		383	455						
			$n_{2 \text{ th}}$		383	455						
8.9	183	0.49	M_2				104	58	94	46		
			c				1.7	2.8	1.5	2.8		
			$n_{2 \text{ Eck}}$				184	225	388	461		
			$n_{2 \text{ th}}$				184	225	388	403		
11.25	114	0.32	M_2	22								
			c	3.7								
			$n_{2 \text{ Eck}}$	351								
			$n_{2 \text{ th}}$	351								
11.25	136	0.32	M_2		69	44						
			c		1.5	2.2						
			$n_{2 \text{ Eck}}$		303	360						
			$n_{2 \text{ th}}$		303	360						

$M \dots$ [Nm]
 $n \dots$ [min^{-1}]
 $J \dots$ [kgcm^2]

$P \dots$ [kW]
 $I \dots$ [A]
 $i \dots$ [-]
 $c \dots$ [-]

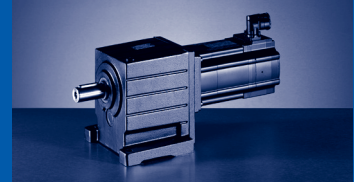

$M_{2GN} \leq 196 \text{ Nm}$

17NC35	17NC41	19SC17	19SC23	19SC35	19SC42	21XC17	21XC25	21XC42	GST07-1A			
...F10	...S00	...F10	...S00	...F10	...S00	...F10	...S00	...S00	M_1	J_G	M_{2GN}	i
19	9.5	36.3	16.3	36	12	61.4	24.6	17	n_1			
3480	4110	1700	2340	3510	4150	1710	2490	4160	I_{M400}			
15.8	10.2	13.9	8.2	28.7	14	22.5	13.5	19.8	P_N			
6.9	4.1	6.4	4	13.2	5.2	11	6.4	7.4	J_M			
36.04	36.04	72.12	72.12	72.04	72.12	180.04	180.04	180.04	M_2 c			
									n_{2Eck}	0.49	113	8.9
									n_{2th}			
									M_2 c			
									n_{2Eck}	0.49	164	8.9
									n_{2th}			
									M_2 c			
									n_{2Eck}	0.49	183	8.9
									n_{2th}			
									M_2 c			
									n_{2Eck}	0.32	114	11.25
									n_{2th}			
									M_2 c			
									n_{2Eck}	0.32	136	11.25
									n_{2th}			

M ... [Nm]
n ... [min⁻¹]
J ... [kgcm²]

P ... [kW]
I ... [A]
i [-]
c [-]

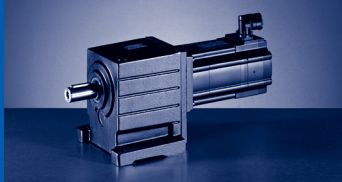

GST [Nm]

GST□□-□A (MCA)

$M_{2GN} \leq 707 \text{ Nm}$

GST07-2A				10IC40	13IC34	13IC41	14LC16	14LC20	14LC35	14LC41	17NC17	17NC23	
				...S00	...F10	...S00	...F10	...S00	...F10	...S00	...F10	...S00	
i	M_{2GN}	J_G	M_1	2	6.3	4	12	6.7	10.8	5.4	21.5	10.8	
			n_1	3950	3410	4050	1635	2000	3455	4100	1680	2300	
			I_{M400}	2.4	6	4.4	4.8	3.3	9.1	5.8	8.5	5.5	
			P_N	0.8	2.2	1.7	2.1	1.4	3.9	2.3	3.8	2.6	
			J_M	2.44	8.34	8.34	19.32	19.24	19.24	19.24	36.04	36.04	
3.048	317	8.2	M_2								61		
			c								4.8		
			n_2 Eck									551	
			n_2 th									551	
3.048	351	8.2	M_2										
			c										
			n_2 Eck										
			n_2 th										
3.35	349	7.92	M_2								67		
			c								4.8		
			n_2 Eck								502		
			n_2 th								502		
3.35	367	7.92	M_2										
			c										
			n_2 Eck										
			n_2 th										
4.225	398	7.65	M_2								85		
			c								4.4		
			n_2 Eck								398		
			n_2 th								398		
4.643	414	7.39	M_2								94		
			c								4.1		
			n_2 Eck								362		
			n_2 th								362		
5.2	405	5.64	M_2						52				
			c						5.6				
			n_2 Eck						664				
			n_2 th						560				
5.2	427	5.64	M_2								105		
			c								3.8		
			n_2 Eck								323		
			n_2 th								323		
5.714	445	5.46	M_2						57				
			c						5.6				
			n_2 Eck						605				
			n_2 th						510				
5.714	448	5.46	M_2								116		
			c								3.6		
			n_2 Eck								294		
			n_2 th								294		
6.4	463	4.49	M_2						64		130	64	
			c						5.2		3.3	6	
			n_2 Eck						540		263	359	
			n_2 th						466		263	359	
7.15	489	6.27	M_2								146	71	
			c								3.2	5.7	
			n_2 Eck								235	322	
			n_2 th								235	322	
8.125	539	6.04	M_2								166	81	
			c								3.1	5.5	
			n_2 Eck								207	283	
			n_2 th								207	283	

$M \dots$ [Nm]
 $n \dots$ [min^{-1}]
 $J \dots$ [kgcm^2]

$P \dots$ [kW]
 $I \dots$ [A]
 $i \dots$ [-]
 $c \dots$ [-]



$M_{2GN} \leq 707 \text{ Nm}$

17NC35	17NC41	19SC17	19SC23	19SC35	19SC42	21XC17	21XC25	21XC35	21XC42	GST07-2A			
...F10	...S00	...F10	...S00	...F10	...S00	...F10	...S00	...F10	...S00	M_1	J_G	M_{2GN}	i
19	9.5	36.3	16.3	36	12	61.4	24.6	55	17	n_1			
3480	4110	1700	2340	3510	4150	1710	2490	3520	4160	I_{M400}			
15.8	10.2	13.9	8.2	28.7	14	22.5	13.5	42.5	19.8	P_N			
6.9	4.1	6.4	4	13.2	5.2	11	6.4	20.3	7.4	J_M			
36.04	36.04	72.12	72.12	72.04	72.12	180.04	180.04	180.04	180.04	M_2			
54										c			
4.3										$n_{2 \text{ Eck}}$	8.2	317	3.048
1142										$n_{2 \text{ th}}$			
693										M_2			
		105		105		180	70	162	48	c			
		3.1		2.5		1.9	4.1	1.6	5	$n_{2 \text{ Eck}}$	8.2	351	3.048
		558		1152		561	817	1155	1365	$n_{2 \text{ th}}$			
		558		610		554	661	511	661	M_2			
60										c			
4.3										$n_{2 \text{ Eck}}$	7.92	349	3.35
1039										$n_{2 \text{ th}}$			
631										M_2			
		116	50	115		198	78	178	53	c			
		3	6	2.4		1.8	3.9	1.5	4.7	$n_{2 \text{ Eck}}$	7.92	367	3.35
		508	699	1048		511	743	1051	1242	$n_{2 \text{ th}}$			
		508	678	548		488	601	451	601	M_2			
76		146	64	146	47	250	98	225	67	c			
3.9		2.6	5.1	2	5.8	1.5	3.3	1.3	4.1	$n_{2 \text{ Eck}}$	7.65	398	4.225
824		402	554	831	982	405	589	833	985	$n_{2 \text{ th}}$			
564		402	554	487	580	405	477	386	477	M_2			
83		161	71	161	52	275	108	247	74	c			
3.7		2.4	4.9	1.9	5.5	1.4	3.2	1.3	3.9	$n_{2 \text{ Eck}}$	7.39	414	4.643
750		366	504	756	894	368	536	758	896	$n_{2 \text{ th}}$			
507		366	504	434	527	366	434	341	434	M_2			
										c			
										$n_{2 \text{ Eck}}$	5.64	405	5.2
										$n_{2 \text{ th}}$			
94		181	79	180	58	309	122	277	84	M_2			
3.4		2.2	4.5	1.8	5	1.3	2.9	1.2	3.6	c			
669		327	450	675	798	329	479	677	800	$n_{2 \text{ Eck}}$	5.64	427	5.2
504		327	450	417	471	329	387	330	387	$n_{2 \text{ th}}$			
										M_2			
										c			
										$n_{2 \text{ Eck}}$	5.46	445	5.714
										$n_{2 \text{ th}}$			
103		199	87	198	64	339	134	305	92	M_2			
3.2		2.1	4.3	1.7	4.8	1.3	2.8	1.1	3.4	c			
609		298	410	614	726	299	436	616	728	$n_{2 \text{ Eck}}$	5.46	448	5.714
454		298	410	369	429	299	352	293	352	$n_{2 \text{ th}}$			
116	56	223	98	222	72	381	150	341	103	M_2			
3	5.6	2	4	1.6	4.4	1.2	2.6	1	3.1	c			
544	642	266	366	548	648	267	389	550	650	$n_{2 \text{ Eck}}$	4.49	463	6.4
415	472	266	366	332	383	267	315	269	315	$n_{2 \text{ th}}$			
129	63	250	110	249	81	426	168		116	M_2			
2.8	5.3	1.9	3.7	1.5	4.2	1.1	2.4		3	c			
487	575	238	327	491	580	239	348		582	$n_{2 \text{ Eck}}$	6.27	489	7.15
311	356	238	327	241	339	207	282		282	$n_{2 \text{ th}}$			
147	72	284	125	283	92	484	191		131	M_2			
2.7	5.1	1.8	3.6	1.4	4.1	1.1	2.4		2.9	c			
428	506	209	288	432	511	211	307		512	$n_{2 \text{ Eck}}$	6.04	539	8.125
271	311	209	288	209	297	180	248		248	$n_{2 \text{ th}}$			

$M \dots$ [Nm]
 $n \dots$ [min^{-1}]
 $J \dots$ [kgcm^2]

$P \dots$ [kW]
 $I \dots$ [A]
 i [-]
 c [-]

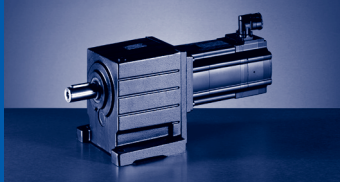

GST [Nm]

GST□□-□A (MCA)

$M_{2GN} \leq 707 \text{ Nm}$

GST07-2A				10IC40	13IC34	13IC41	14LC16	14LC20	14LC35	14LC41	17NC17	17NC23
				...500	...F10	...500	...F10	...500	...F10	...500	...F10	...500
i	M_{2GN}	J_G	M_1	2	6.3	4	12	6.7	10.8	5.4	21.5	10.8
			n_1	3950	3410	4050	1635	2000	3455	4100	1680	2300
			I_{M400}	2.4	6	4.4	4.8	3.3	9.1	5.8	8.5	5.5
			P_N	0.8	2.2	1.7	2.1	1.4	3.9	2.3	3.8	2.6
			J_M	2.44	8.34	8.34	19.32	19.24	19.24	19.24	36.04	36.04
8.8	527	4.73	M_2				98		89		180	88
			c				5		4.3		2.8	5
			$n_{2 \text{ Eck}}$				186		393		191	261
			$n_{2 \text{ th}}$				186		314		191	261
9.856	549	3.9	M_2				110		100		202	99
			c				4.7		4		2.6	4.6
			$n_{2 \text{ Eck}}$				166		351		171	233
			$n_{2 \text{ th}}$				166		287		170	233
11.2	598	3.78	M_2				126		114		230	113
			c				4.5		3.9		2.5	4.4
			$n_{2 \text{ Eck}}$				146		309		150	205
			$n_{2 \text{ th}}$				146		251		150	205
12.571	513	2.86	M_2		74							
			c		5.1							
			$n_{2 \text{ Eck}}$		271							
			$n_{2 \text{ th}}$		271							
12.571	601	2.86	M_2				142		128		259	128
			c				4		3.5		2.2	4
			$n_{2 \text{ Eck}}$				130		275		134	183
			$n_{2 \text{ th}}$				130		255		134	183
14.286	583	2.79	M_2		84							
			c		5.1							
			$n_{2 \text{ Eck}}$		239							
			$n_{2 \text{ th}}$		239							
14.286	642	2.79	M_2				162		146		295	146
			c				3.8		3.3		2.1	3.7
			$n_{2 \text{ Eck}}$				115		242		118	161
			$n_{2 \text{ th}}$				114		222		118	161
15.4	644	2.26	M_2				175		157		318	156
			c				3.6		3.4		2	3.9
			$n_{2 \text{ Eck}}$				106		224		109	149
			$n_{2 \text{ th}}$				106		224		109	149
17.5	680	2.21	M_2				199	108	179		362	178
			c				3.3	6	3.2		1.9	3.7
			$n_{2 \text{ Eck}}$				93	114	197		96	131
			$n_{2 \text{ th}}$				93	114	197		96	131
20.044	650	1.38	M_2		118							
			c		4.6							
			$n_{2 \text{ Eck}}$		170							
			$n_{2 \text{ th}}$		170							
20.044	694	1.38	M_2				229	124	206	100	415	205
			c				3	5.3	2.8	5.4	1.7	3.3
			$n_{2 \text{ Eck}}$				82	100	172	205	84	115
			$n_{2 \text{ th}}$				82	100	172	179	84	115
22.778	682	1.35	M_2		135		261	143	235	115	473	234
			c		4.2		2.6	4.6	2.5	4.6	1.4	2.8
			$n_{2 \text{ Eck}}$		150		72	88	152	180	74	101
			$n_{2 \text{ th}}$		150		72	88	152	158	74	101
24.567	677	1.02	M_2		146	91						
			c		3.9	5.8						
			$n_{2 \text{ Eck}}$		139	165						
			$n_{2 \text{ th}}$		139	165						

$M \dots$ [Nm]
 $n \dots$ [min^{-1}]
 $J \dots$ [kgcm^2]

$P \dots$ [kW]
 $I \dots$ [A]
 $i \dots$ [-]
 $c \dots$ [-]

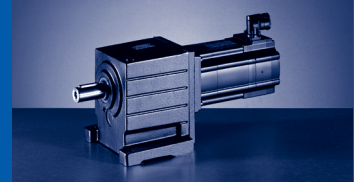

$M_{2GN} \leq 707 \text{ Nm}$

17NC35	17NC41	19SC17	19SC23	19SC35	19SC42	21XC17	21XC25	21XC35	21XC42	GST07-2A			
...F10	...S00	...F10	...S00	...F10	...S00	...F10	...S00	...F10	...S00				
19	9.5	36.3	16.3	36	12	61.4	24.6	55	17	M_1	J_G	M_{2GN}	i
3480	4110	1700	2340	3510	4150	1710	2490	3520	4160	n_1			
15.8	10.2	13.9	8.2	28.7	14	22.5	13.5	42.5	19.8	I_{M400}			
6.9	4.1	6.4	4	13.2	5.2	11	6.4	20.3	7.4	P_N			
36.04	36.04	72.12	72.12	72.04	72.12	180.04	180.04	180.04	180.04	J_M			
160	78	308	136	306	100		208		143	M_2			
2.5	4.6	1.6	3.3	1.3	3.7		2.1		2.6	c	4.73	527	8.8
396	467	193	266	399	472		283		473	$n_{2\text{ Eck}}$			
277	318	193	266	206	278		229		229	$n_{2\text{ th}}$			
179	88	345	153	344	112		233		160	M_2			
2.3	4.3	1.5	3	1.2	3.4		2		2.4	c	3.9	549	9.856
353	417	173	237	356	421		253		422	$n_{2\text{ Eck}}$			
255	292	172	237	189	248		204		204	$n_{2\text{ th}}$			
204	100	393	174	391	127		265		182	M_2			
2.2	4.1	1.5	2.9	1.2	3.3		1.9		2.3	c	3.78	598	11.2
311	367	152	209	313	371		222		371	$n_{2\text{ Eck}}$			
222	254	152	209	163	219		180		180	$n_{2\text{ th}}$			
										M_2			
										c	2.86	513	12.571
										$n_{2\text{ Eck}}$			
										$n_{2\text{ th}}$			
229	113	441	196	439	143					M_2			
2	3.7	1.3	2.6	1	2.9					c	2.86	601	12.571
277	327	135	186	279	330					$n_{2\text{ Eck}}$			
226	247	135	186	161	195					$n_{2\text{ th}}$			
										M_2			
										c	2.79	583	14.286
										$n_{2\text{ Eck}}$			
										$n_{2\text{ th}}$			
261	128	502	223		163					M_2			
1.8	3.5	1.2	2.5		2.8					c	2.79	642	14.286
244	288	119	164		291					$n_{2\text{ Eck}}$			
192	218	119	164		171					$n_{2\text{ th}}$			
281	138	541	240	538	176					M_2			
2	3.7	1.2	2.6	1	2.9					c	2.26	644	15.4
226	267	110	152	228	270					$n_{2\text{ Eck}}$			
202	202	110	152	150	159					$n_{2\text{ th}}$			
320	157	616	273		200					M_2			
1.8	3.4	1.1	2.4		2.7					c	2.21	680	17.5
199	235	97	134		237					$n_{2\text{ Eck}}$			
171	178	97	134		140					$n_{2\text{ th}}$			
										M_2			
										c	1.38	650	20.044
										$n_{2\text{ Eck}}$			
										$n_{2\text{ th}}$			
367	181									M_2			
1.6	3.1									c	1.38	694	20.044
174	205									$n_{2\text{ Eck}}$			
155	155									$n_{2\text{ th}}$			
418	206									M_2			
1.4	2.6									c	1.35	682	22.778
153	180									$n_{2\text{ Eck}}$			
137	137									$n_{2\text{ th}}$			
										M_2			
										c	1.02	677	24.567
										$n_{2\text{ Eck}}$			
										$n_{2\text{ th}}$			

$M \dots$ [Nm]
 $n \dots$ [min^{-1}]
 $J \dots$ [kgcm^2]

$P \dots$ [kW]
 $I \dots$ [A]
 $i [-]$
 $c [-]$

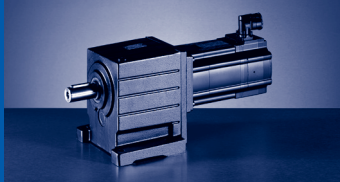

GST [Nm]

GST□□-□A (MCA)

$M_{2GN} \leq 707 \text{ Nm}$

GST07-2A				10IC40	13IC34	13IC41	14LC16	14LC20	14LC35	14LC41	17NC17	17NC23
				...S00	...F10	...S00	...F10	...S00	...F10	...S00	...F10	...S00
i	M_{2GN}	J_G	M_1	2	6.3	4	12	6.7	10.8	5.4	21.5	10.8
			n_1	3950	3410	4050	1635	2000	3455	4100	1680	2300
			I_{M400}	2.4	6	4.4	4.8	3.3	9.1	5.8	8.5	5.5
			P_N	0.8	2.2	1.7	2.1	1.4	3.9	2.3	3.8	2.6
			J_M	2.44	8.34	8.34	19.32	19.24	19.24	19.24	36.04	36.04
24.567	706	1.02	M_2				282	154	254	124	510	253
			c				2.5	4.4	2.4	4.5	1.4	2.7
			$n_{2 \text{ Eck}}$				67	81	141	167	68	94
			$n_{2 \text{ th}}$				67	81	141	146	68	94
27.917	691	1.01	M_2		166	104	321	176	289	142	581	289
			c		3.5	5.2	2.1	3.8	2	3.8	1.2	2.3
			$n_{2 \text{ Eck}}$		122	145	59	72	124	147	60	82
			$n_{2 \text{ th}}$		122	145	59	72	124	129	60	82
32.267	698	0.66	M_2		193	121						
			c		3.1	4.6						
			$n_{2 \text{ Eck}}$		106	126						
			$n_{2 \text{ th}}$		106	126						
32.267	706	0.66	M_2				372	205	335	165		
			c				1.9	3.4	1.8	3.4		
			$n_{2 \text{ Eck}}$				51	62	107	127		
			$n_{2 \text{ th}}$				51	62	107	111		
36.667	702	0.65	M_2		220	138	424	234	382	188		
			c		2.7	4	1.6	3	1.6	3		
			$n_{2 \text{ Eck}}$		93	111	45	55	94	112		
			$n_{2 \text{ th}}$		93	110	45	55	94	98		
39.16	491	0.49	M_2	73								
			c	5.3								
			$n_{2 \text{ Eck}}$	101								
			$n_{2 \text{ th}}$	101								
39.16	706	0.49	M_2		236	148	453	250	408	201		
			c		2.6	3.8	1.6	2.8	1.5	2.8		
			$n_{2 \text{ Eck}}$		87	103	42	51	88	105		
			$n_{2 \text{ th}}$		87	103	42	51	88	92		
44.5	558	0.48	M_2	82								
			c	5.9								
			$n_{2 \text{ Eck}}$	89								
			$n_{2 \text{ th}}$	89								
44.5	707	0.48	M_2		268	168	516	285	464	229		
			c		2.5	3.7	1.4	2.4	1.5	2.7		
			$n_{2 \text{ Eck}}$		77	91	37	45	78	92		
			$n_{2 \text{ th}}$		77	91	37	45	78	81		
49.5	493	0.33	M_2	92								
			c	4.7								
			$n_{2 \text{ Eck}}$	80								
			$n_{2 \text{ th}}$	80								
49.5	600	0.33	M_2		300	188						
			c		1.9	2.8						
			$n_{2 \text{ Eck}}$		69	82						
			$n_{2 \text{ th}}$		69	82						
56.25	560	0.33	M_2	105								
			c	4.7								
			$n_{2 \text{ Eck}}$	70								
			$n_{2 \text{ th}}$	70								
56.25	688	0.33	M_2		341	214						
			c		1.9	2.9						
			$n_{2 \text{ Eck}}$		61	72						
			$n_{2 \text{ th}}$		61	72						

$M \dots$ [Nm]
 $n \dots$ [min^{-1}]
 $J \dots$ [kgcm^2]

$P \dots$ [kW]
 $I \dots$ [A]
 $i \dots$ [-]
 $c \dots$ [-]

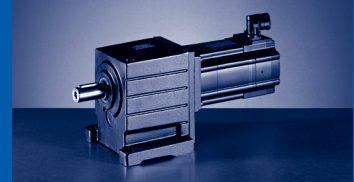

$M_{2GN} \leq 707 \text{ Nm}$

17NC35	17NC41	19SC17	19SC23	19SC35	19SC42	21XC17	21XC25	21XC35	21XC42	GST07-2A			
...F10	...S00	...F10	...S00	...F10	...S00	...F10	...S00	...F10	...S00	M_1	J_G	M_{2GN}	i
19	9.5	36.3	16.3	36	12	61.4	24.6	55	17	n_1			
3480	4110	1700	2340	3510	4150	1710	2490	3520	4160	I_{M400}			
15.8	10.2	13.9	8.2	28.7	14	22.5	13.5	42.5	19.8	P_N			
6.9	4.1	6.4	4	13.2	5.2	11	6.4	20.3	7.4	J_M			
36.04	36.04	72.12	72.12	72.04	72.12	180.04	180.04	180.04	180.04	M_2			
451	223									c			
1.3	2.5									n_{2Eck}	1.02	706	24.567
142	167									n_{2th}			
127	127									M_2			
514	254									c			
1.2	2.2									n_{2Eck}	1.01	691	27.917
125	147									n_{2th}			
111	111									M_2			
										c			
										n_{2Eck}	0.66	698	32.267
										n_{2th}			
										M_2			
										c			
										n_{2Eck}	0.66	706	32.267
										n_{2th}			
										M_2			
										c			
										n_{2Eck}	0.65	702	36.667
										n_{2th}			
										M_2			
										c			
										n_{2Eck}	0.49	491	39.16
										n_{2th}			
										M_2			
										c			
										n_{2Eck}	0.49	706	39.16
										n_{2th}			
										M_2			
										c			
										n_{2Eck}	0.48	558	44.5
										n_{2th}			
										M_2			
										c			
										n_{2Eck}	0.48	707	44.5
										n_{2th}			
										M_2			
										c			
										n_{2Eck}	0.33	493	49.5
										n_{2th}			
										M_2			
										c			
										n_{2Eck}	0.33	600	49.5
										n_{2th}			
										M_2			
										c			
										n_{2Eck}	0.33	560	56.25
										n_{2th}			
										M_2			
										c			
										n_{2Eck}	0.33	688	56.25
										n_{2th}			

M ... [Nm]
n ... [min⁻¹]
J ... [kgcm²]

P ... [kW]
I ... [A]
i [-]
c [-]

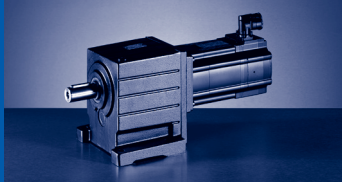

GST [Nm]

GST□□-□A (MCA)

$M_{2GN} \leq 710 \text{ Nm}$

GST07-3A				10IC40	13IC34	13IC41	14LC16	14LC20	14LC35	14LC41
				...S00	...F10	...S00	...F10	...S00	...F10	...S00
i	M_{2GN}	J_G	M_1	2	6.3	4	12	6.7	10.8	5.4
			n_1	3950	3410	4050	1635	2000	3455	4100
			I_{M400}	2.4	6	4.4	4.8	3.3	9.1	5.8
			P_N	0.8	2.2	1.7	2.1	1.4	3.9	2.3
			J_M	2.44	8.34	8.34	19.32	19.24	19.24	19.24
39.2	692	0.97	M_2		232	146	447	246	403	199
			c		2.5	3.8	1.5	2.8	1.5	2.8
			$n_{2 \text{ Eck}}$		87	103	42	51	88	105
			$n_{2 \text{ th}}$		87	103	42	51	88	92
44	706	0.53	M_2		261	163	502	277	452	223
			c		2.6	3.8	1.4	2.5	1.5	2.8
			$n_{2 \text{ Eck}}$		78	92	37	46	79	93
			$n_{2 \text{ th}}$		78	92	37	45	79	82
51.022	700	0.84	M_2		303	190	584	323	525	259
			c		2.2	3.3	1.2	2.1	1.3	2.4
			$n_{2 \text{ Eck}}$		67	79	32	39	68	80
			$n_{2 \text{ th}}$		67	79	32	39	68	70
53.9	706	0.48	M_2		321	202	617	341	555	274
			c		2.1	3.1	1.1	2.1	1.2	2.3
			$n_{2 \text{ Eck}}$		63	75	30	37	64	76
			$n_{2 \text{ th}}$		63	75	30	37	64	67
65.079	707	0.31	M_2	119	389	245				
			c	5.2	1.7	2.6				
			$n_{2 \text{ Eck}}$	61	52	62				
			$n_{2 \text{ th}}$	61	52	62				
70.156	706	0.43	M_2	129	420	264		447		359
			c	4.8	1.6	2.4		1.6		1.8
			$n_{2 \text{ Eck}}$	56	49	58		29		58
			$n_{2 \text{ th}}$	56	49	58		29		51
79.762	710	0.54	M_2	147	478	301		509		409
			c	4.3	1.4	2.1		1.4		1.6
			$n_{2 \text{ Eck}}$	50	43	51		25		51
			$n_{2 \text{ th}}$	50	43	51		25		45
85.983	706	0.4	M_2	159	516	325		549		442
			c	3.9	1.3	1.9		1.3		1.4
			$n_{2 \text{ Eck}}$	46	40	47		23		48
			$n_{2 \text{ th}}$	46	40	47		23		42
97.708	710	0.4	M_2	182	587	371		625		503
			c	3.5	1.2	1.7		1.1		1.3
			$n_{2 \text{ Eck}}$	40	35	42		21		42
			$n_{2 \text{ th}}$	40	35	41		20		37
111.915	706	0.24	M_2	209	674	426				
			c	3	1	1.5				
			$n_{2 \text{ Eck}}$	35	31	36				
			$n_{2 \text{ th}}$	35	30	36				
127.176	710	0.24	M_2	239		485				
			c	2.7		1.3				
			$n_{2 \text{ Eck}}$	31		32				
			$n_{2 \text{ th}}$	31		32				
139.211	706	0.17	M_2	262		531				
			c	2.4		1.2				
			$n_{2 \text{ Eck}}$	28		29				
			$n_{2 \text{ th}}$	28		29				
158.194	710	0.17	M_2	299		604				
			c	2.1		1.1				
			$n_{2 \text{ Eck}}$	25		26				
			$n_{2 \text{ th}}$	25		26				

$M \dots$ [Nm]
 $n \dots$ [min^{-1}]
 $J \dots$ [kgcm^2]

$P \dots$ [kW]
 $I \dots$ [A]
 i [-]
 c [-]

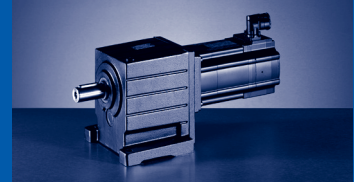

$M_{2GN} \leq 710 \text{ Nm}$

GST07-3A				10IC40	13IC34	13IC41	14LC16	14LC20	14LC35	14LC41
				...S00	...F10	...S00	...F10	...S00	...F10	...S00
i	M_{2GN}	J_G	M_1	2	6.3	4	12	6.7	10.8	5.4
			n_1	3950	3410	4050	1635	2000	3455	4100
			I_{M400}	2.4	6	4.4	4.8	3.3	9.1	5.8
			P_N	0.8	2.2	1.7	2.1	1.4	3.9	2.3
			J_M	2.44	8.34	8.34	19.32	19.24	19.24	19.24
180.156	706	0.11	M_2	341						
			c	1.9						
			$n_2 \text{ Eck}$	22						
			$n_2 \text{ th}$	22						
204.722	710	0.11	M_2	389						
			c	1.7						
			$n_2 \text{ Eck}$	19						
			$n_2 \text{ th}$	19						
236.622	706	0.1	M_2	450						
			c	1.4						
			$n_2 \text{ Eck}$	17						
			$n_2 \text{ th}$	17						
248.458	710	0.08	M_2	473						
			c	1.4						
			$n_2 \text{ Eck}$	16						
			$n_2 \text{ th}$	16						
268.889	710	0.1	M_2	513						
			c	1.3						
			$n_2 \text{ Eck}$	15						
			$n_2 \text{ th}$	15						
326.333	710	0.07	M_2	623						
			c	1						
			$n_2 \text{ Eck}$	12						
			$n_2 \text{ th}$	12						

$M \dots$ [Nm]
 $n \dots$ [min^{-1}]
 $J \dots$ [kgcm^2]

$P \dots$ [kW]
 $I \dots$ [A]
 $i \dots$ [-]
 $c \dots$ [-]

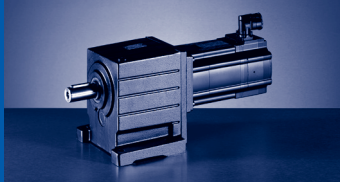

GST [Nm]

GST□□-□A (MCA)

$M_{2GN} \leq 465 \text{ Nm}$

GST09-1A				14LC16	14LC20	14LC35	14LC41	17NC17	17NC23	17NC35	17NC41
				...F10	...S00	...F10	...S00	...F10	...S00	...F10	...S00
i	M_{2GN}	J_G	M_1	12	6.7	10.8	5.4	21.5	10.8	19	9.5
			n_1	1635	2000	3455	4100	1680	2300	3480	4110
			I_{M400}	4.8	3.3	9.1	5.8	8.5	5.5	15.8	10.2
			P_N	2.1	1.4	3.9	2.3	3.8	2.6	6.9	4.1
			J_M	19.32	19.24	19.24	19.24	36.04	36.04	36.04	36.04
1.56	277	22.2	M_2 c $n_{2 \text{ Eck}}$ $n_{2 \text{ th}}$								
2.048	239	15.6	M_2 c $n_{2 \text{ Eck}}$ $n_{2 \text{ th}}$					41 5.3 821 820		37 4.7 1700 1109	
2.048	338	15.6	M_2 c $n_{2 \text{ Eck}}$ $n_{2 \text{ th}}$								
2.333	245	12.2	M_2 c $n_{2 \text{ Eck}}$ $n_{2 \text{ th}}$					48 4.8 720 720		42 4.2 1491 1042	
2.333	370	12.2	M_2 c $n_{2 \text{ Eck}}$ $n_{2 \text{ th}}$								
2.81	221	9.58	M_2 c $n_{2 \text{ Eck}}$ $n_{2 \text{ th}}$			28 5.6 1230 1035					
2.81	259	9.58	M_2 c $n_{2 \text{ Eck}}$ $n_{2 \text{ th}}$					58 4.2 598 598		51 3.7 1239 952	
2.81	418	9.58	M_2 c $n_{2 \text{ Eck}}$ $n_{2 \text{ th}}$								
3.444	272	7.3	M_2 c $n_{2 \text{ Eck}}$ $n_{2 \text{ th}}$					71 3.6 488 488		63 3.2 1010 818	
3.444	443	7.3	M_2 c $n_{2 \text{ Eck}}$ $n_{2 \text{ th}}$								
4.667	247	4.6	M_2 c $n_{2 \text{ Eck}}$ $n_{2 \text{ th}}$	53 4.3 350 350		48 3.8 740 740					
4.667	289	4.6	M_2 c $n_{2 \text{ Eck}}$ $n_{2 \text{ th}}$					97 2.8 360 360	48 5 493 493	86 2.5 746 667	42 4.7 881 667
4.667	379	4.6	M_2 c $n_{2 \text{ Eck}}$ $n_{2 \text{ th}}$								

$M \dots$ [Nm]
 $n \dots$ [min^{-1}]
 $J \dots$ [kgcm^2]

$P \dots$ [kW]
 $I \dots$ [A]
 $i \dots$ [-]
 $c \dots$ [-]



$M_{2GN} \leq 465 \text{ Nm}$

195C17	195C23	195C35	195C42	21XC17	21XC25	21XC35	21XC42	GST09-1A			
...F10	...500	...F10	...500	...F10	...500	...F10	...500	M_1	J_G	M_{2GN}	i
36.3	16.3	36	12	61.4	24.6	55	17	n_1			
1700	2340	3510	4150	1710	2490	3520	4160	I_{M400}			
13.9	8.2	28.7	14	22.5	13.5	42.5	19.8	P_N			
6.4	4	13.2	5.2	11	6.4	20.3	7.4	J_M			
72.12	72.12	72.04	72.12	180.04	180.04	180.04	180.04	M_2			
54		54		93		83		c	22.2	277	1.56
4.8		3.8		2.8		2.5		$n_{2 \text{ Eck}}$			
1090		2250		1096		2256		$n_{2 \text{ th}}$			
1090		1219		1096		1101		M_2			
								c	15.6	239	2.048
								$n_{2 \text{ Eck}}$			
								$n_{2 \text{ th}}$			
71		71		122	47	109		M_2	15.6	338	2.048
4.4		3.5		2.6	5.8	2.3		c			
830		1714		835	1216	1719		$n_{2 \text{ Eck}}$			
830		1041		835	983	943		$n_{2 \text{ th}}$			
								M_2	12.2	245	2.333
								c			
								$n_{2 \text{ Eck}}$			
								$n_{2 \text{ th}}$			
81		81		139	54	125		M_2	12.2	370	2.333
4.3		3.4		2.5	5.5	2.2		c			
729		1504		733	1067	1509		$n_{2 \text{ Eck}}$			
729		991		733	863	863		$n_{2 \text{ th}}$			
								M_2	9.58	221	2.81
								c			
								$n_{2 \text{ Eck}}$			
								$n_{2 \text{ th}}$			
97		97		168	65	151		M_2	9.58	418	2.81
4		3.2		2.4	5.2	2.1		c			
605		1249		609	886	1253		$n_{2 \text{ Eck}}$			
605		872		609	717	717		$n_{2 \text{ th}}$			
								M_2	7.3	272	3.444
								c			
								$n_{2 \text{ Eck}}$			
								$n_{2 \text{ th}}$			
120		120		206	81	185	55	M_2	7.3	443	3.444
3.5		2.7		2	4.5	1.8	5.5	c			
494		1019		497	723	1022	1208	$n_{2 \text{ Eck}}$			
494		711		496	585	585	585	$n_{2 \text{ th}}$			
								M_2	4.6	247	4.667
								c			
								$n_{2 \text{ Eck}}$			
								$n_{2 \text{ th}}$			
165	72	164	53					M_2	4.6	379	4.667
2.2	4.4	1.7	4.9					c			
364	501	752	889					$n_{2 \text{ Eck}}$			
364	501	525	525					$n_{2 \text{ th}}$			

M ... [Nm]
n ... [min⁻¹]
J ... [kgcm²]

P ... [kW]
I ... [A]
i [-]
c [-]

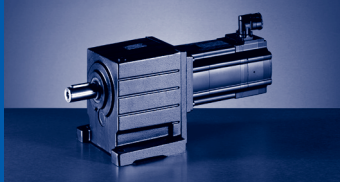

GST [Nm]

GST□□-□A (MCA)

$M_{2GN} \leq 465 \text{ Nm}$

GST09-1A				14LC16	14LC20	14LC35	14LC41	17NC17	17NC23	17NC35	17NC41
				...F10	...S00	...F10	...S00	...F10	...S00	...F10	...S00
i	M_{2GN}	J_G	M_1								
			n_1	12	6.7	10.8	5.4	21.5	10.8	19	9.5
			I_{M400}	1635	2000	3455	4100	1680	2300	3480	4110
			P_N	4.8	3.3	9.1	5.8	8.5	5.5	15.8	10.2
			J_M	2.1	1.4	3.9	2.3	3.8	2.6	6.9	4.1
			M_2	19.32	19.24	19.24	19.24	36.04	36.04	36.04	36.04
			c	65		59					
5.667	256	3.51	$n_{2 \text{ Eck}}$	3.7		3.2					
			$n_{2 \text{ th}}$	289		610					
			$n_{2 \text{ th}}$	289		610					
			M_2					118	58	105	51
5.667	299	3.51	c					2.4	4.3	2.1	4
			$n_{2 \text{ Eck}}$					297	406	614	725
			$n_{2 \text{ th}}$					296	406	549	549
			M_2								
5.667	465	3.51	c								
			$n_{2 \text{ Eck}}$								
			$n_{2 \text{ th}}$								
			M_2	85	46	77	37				
7.333	265	2.26	c	3	5	2.6	4.9				
			$n_{2 \text{ Eck}}$	223	273	471	559				
			$n_{2 \text{ th}}$	223	273	471	490				
			M_2					154	76	136	67
7.333	310	2.26	c					1.9	3.4	1.7	3.2
			$n_{2 \text{ Eck}}$					229	314	475	561
			$n_{2 \text{ th}}$					229	314	424	424
			M_2	104	57	94	46				
8.9	269	1.66	c	2.5	4.2	2.2	4.1				
			$n_{2 \text{ Eck}}$	184	225	388	461				
			$n_{2 \text{ th}}$	184	225	388	403				
			M_2					187	93	166	82
8.9	315	1.66	c					1.6	2.9	1.4	2.7
			$n_{2 \text{ Eck}}$					189	258	391	462
			$n_{2 \text{ th}}$					189	258	350	350
			M_2	132	72	119	58				
11.25	273	1.11	c	2	3.3	1.7	3.3				
			$n_{2 \text{ Eck}}$	145	178	307	364				
			$n_{2 \text{ th}}$	145	178	307	319				

M ... [Nm]
 n ... [min^{-1}]
 J ... [kgcm^2]

P ... [kW]
 I ... [A]
 i [-]
 c [-]

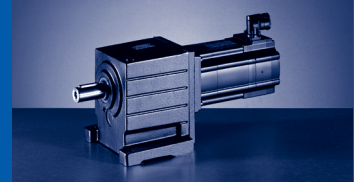

$M_{2GN} \leq 465 \text{ Nm}$

195C17	195C23	195C35	195C42	21XC17	21XC25	21XC35	21XC42	GST09-1A			
...F10	...S00	...F10	...S00	...F10	...S00	...F10	...S00	M_1	J_G	M_{2GN}	i
36.3	16.3	36	12	61.4	24.6	55	17	n_1			
1700	2340	3510	4150	1710	2490	3520	4160	I_{M400}			
13.9	8.2	28.7	14	22.5	13.5	42.5	19.8	P_N			
6.4	4	13.2	5.2	11	6.4	20.3	7.4	J_M			
72.12	72.12	72.04	72.12	180.04	180.04	180.04	180.04	M_2 c			
								n_2 Eck	3.51	256	5.667
								n_2 th			
								M_2 c			
								n_2 Eck	3.51	299	5.667
								n_2 th			
200	88	199	64					M_2 c			
2.2	4.4	1.7	5					n_2 Eck	3.51	465	5.667
300	413	619	732					n_2 th			
300	413	432	432					M_2 c			
								n_2 Eck	2.26	265	7.333
								n_2 th			
								M_2 c			
								n_2 Eck	2.26	310	7.333
								n_2 th			
								M_2 c			
								n_2 Eck	1.66	269	8.9
								n_2 th			
								M_2 c			
								n_2 Eck	1.66	315	8.9
								n_2 th			
								M_2 c			
								n_2 Eck	1.11	273	11.25
								n_2 th			

M ... [Nm]
n ... [min⁻¹]
J ... [kgcm²]

P ... [kW]
I ... [A]
i [-]
c [-]

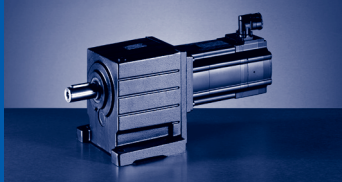

GST [Nm]

GST□□-□A (MCA)

$M_{2GN} \leq 1582 \text{ Nm}$

GST09-2A				14LC16	14LC20	14LC35	14LC41	17NC17	17NC23	17NC35	17NC41
				...F10	...S00	...F10	...S00	...F10	...S00	...F10	...S00
i	M_{2GN}	J_G	M_1	12	6.7	10.8	5.4	21.5	10.8	19	9.5
			n_1	1635	2000	3455	4100	1680	2300	3480	4110
			I_{M400}	4.8	3.3	9.1	5.8	8.5	5.5	15.8	10.2
			P_N	2.1	1.4	3.9	2.3	3.8	2.6	6.9	4.1
			J_M	19.32	19.24	19.24	19.24	36.04	36.04	36.04	36.04
4.056	878	27	M_2								
			c								
			n_2 Eck								
			n_2 th								
4.457	931	25.9	M_2								
			c								
			n_2 Eck								
			n_2 th								
5.324	613	18.1	M_2					106		94	
			c					5.3		4.7	
			n_2 Eck					316		654	
			n_2 th					316		426	
5.324	993	18.1	M_2								
			c								
			n_2 Eck								
			n_2 th								
5.85	674	17.5	M_2					117		104	
			c					5.3		4.7	
			n_2 Eck					287		595	
			n_2 th					287		388	
5.85	1020	17.5	M_2								
			c								
			n_2 Eck								
			n_2 th								
6.667	690	14.2	M_2					134		119	
			c					4.8		4.2	
			n_2 Eck					252		522	
			n_2 th					252		365	
6.667	1065	14.2	M_2								
			c								
			n_2 Eck								
			n_2 th								
7.305	566	11.3	M_2			73					
			c			5.6					
			n_2 Eck			473					
			n_2 th			398					
7.305	663	11.3	M_2					147		131	
			c					4.2		3.7	
			n_2 Eck					230		476	
			n_2 th					230		366	
7.305	1103	11.3	M_2								
			c								
			n_2 Eck								
			n_2 th								
8.027	622	11	M_2			80					
			c			5.6					
			n_2 Eck			430					
			n_2 th			362					
8.027	728	11	M_2					162		144	
			c					4.2		3.7	
			n_2 Eck					209		434	
			n_2 th					209		333	

$M \dots$ [Nm]
 $n \dots$ [min^{-1}]
 $J \dots$ [kgcm^2]

$P \dots$ [kW]
 $I \dots$ [A]
 i [-]
 c [-]

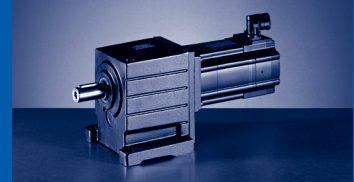

$M_{2GN} \leq 1582 \text{ Nm}$

195C17	195C23	195C35	195C42	21XC17	21XC25	21XC35	21XC42	GST09-2A			
...F10	...500	...F10	...500	...F10	...500	...F10	...500	M_1	J_G	M_{2GN}	i
36.3	16.3	36	12	61.4	24.6	55	17	n_1			
1700	2340	3510	4150	1710	2490	3520	4160	I_{M400}			
13.9	8.2	28.7	14	22.5	13.5	42.5	19.8	P_N			
6.4	4	13.2	5.2	11	6.4	20.3	7.4	J_M			
72.12	72.12	72.04	72.12	180.04	180.04	180.04	180.04	M_2			
136		136		235		212		c			
5.9		4.7		3.5		3.1		$n_{2 \text{ Eck}}$	27	878	4.056
419		865		422		868		$n_{2 \text{ th}}$			
419		492		422		446		M_2			
149		150		259		233		c			
5.7		4.5		3.4		3		$n_{2 \text{ Eck}}$	25.9	931	4.457
381		788		384		790		$n_{2 \text{ th}}$			
381		444		384		403		M_2			
								c			
								$n_{2 \text{ Eck}}$	18.1	613	5.324
								$n_{2 \text{ th}}$			
180		180		311		279		M_2			
5.1		4		3		2.6		c			
319		659		321		661		$n_{2 \text{ Eck}}$	18.1	993	5.324
319		412		321		375		$n_{2 \text{ th}}$			
								M_2			
								c			
								$n_{2 \text{ Eck}}$	17.5	674	5.85
								$n_{2 \text{ th}}$			
198		199		342		307		M_2			
4.8		3.8		2.8		2.5		c			
291		600		292		602		$n_{2 \text{ Eck}}$	17.5	1020	5.85
291		370		292		336		$n_{2 \text{ th}}$			
								M_2			
								c			
								$n_{2 \text{ Eck}}$	14.2	690	6.667
								$n_{2 \text{ th}}$			
227		227		391	151	351		M_2			
4.4		3.5		2.6	5.7	2.3		c			
255		527		257	374	528		$n_{2 \text{ Eck}}$	14.2	1065	6.667
255		349		257	302	302		$n_{2 \text{ th}}$			
								M_2			
								c			
								$n_{2 \text{ Eck}}$	11.3	566	7.305
								$n_{2 \text{ th}}$			
								M_2			
								c			
								$n_{2 \text{ Eck}}$	11.3	663	7.305
								$n_{2 \text{ th}}$			
249		249		429	167	385		M_2			
4.1		3.3		2.4	5.4	2.1		c			
233		481		234	341	482		$n_{2 \text{ Eck}}$	11.3	1103	7.305
233		335		234	276	276		$n_{2 \text{ th}}$			
								M_2			
								c			
								$n_{2 \text{ Eck}}$	11	622	8.027
								$n_{2 \text{ th}}$			
								M_2			
								c			
								$n_{2 \text{ Eck}}$	11	728	8.027
								$n_{2 \text{ th}}$			

M ... [Nm]
n ... [min⁻¹]
J ... [kgcm²]

P ... [kW]
I ... [A]
i [-]
c [-]

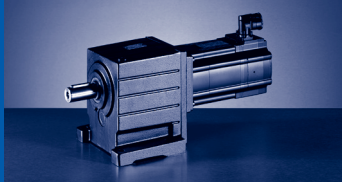

GST [Nm]

GST□□-□A (MCA)

$M_{2GN} \leq 1582 \text{ Nm}$

GST09-2A				14LC16	14LC20	14LC35	14LC41	17NC17	17NC23	17NC35	17NC41
				...F10	...S00	...F10	...S00	...F10	...S00	...F10	...S00
i	M_{2GN}	J_G	M_1	12	6.7	10.8	5.4	21.5	10.8	19	9.5
			n_1	1635	2000	3455	4100	1680	2300	3480	4110
			I_{M400}	4.8	3.3	9.1	5.8	8.5	5.5	15.8	10.2
			P_N	2.1	1.4	3.9	2.3	3.8	2.6	6.9	4.1
			J_M	19.32	19.24	19.24	19.24	36.04	36.04	36.04	36.04
8.027	1133	11	M_2 c $n_{2 \text{ Eck}}$ $n_{2 \text{ th}}$								
9.01	1037	15.2	M_2 c $n_{2 \text{ Eck}}$ $n_{2 \text{ th}}$					180 5.3 187 186		160 4.7 386 252	
9.01	1128	15.2	M_2 c $n_{2 \text{ Eck}}$ $n_{2 \text{ th}}$								
10.267	1063	12.4	M_2 c $n_{2 \text{ Eck}}$ $n_{2 \text{ th}}$					206 4.8 164 164		183 4.2 339 237	
10.267	1178	12.4	M_2 c $n_{2 \text{ Eck}}$ $n_{2 \text{ th}}$								
11.667	1206	12.1	M_2 c $n_{2 \text{ Eck}}$ $n_{2 \text{ th}}$					234 4.8 144 144		208 4.2 298 208	
12.362	958	9.79	M_2 c $n_{2 \text{ Eck}}$ $n_{2 \text{ th}}$			123 5.6 280 235					
12.362	1121	9.79	M_2 c $n_{2 \text{ Eck}}$ $n_{2 \text{ th}}$					249 4.2 136 136		222 3.7 282 216	
12.362	1253	9.79	M_2 c $n_{2 \text{ Eck}}$ $n_{2 \text{ th}}$								
14.048	1088	9.53	M_2 c $n_{2 \text{ Eck}}$ $n_{2 \text{ th}}$			140 5.6 246 207					
14.048	1274	9.53	M_2 c $n_{2 \text{ Eck}}$ $n_{2 \text{ th}}$					283 4.2 120 120		252 3.7 248 190	
14.048	1283	9.53	M_2 c $n_{2 \text{ Eck}}$ $n_{2 \text{ th}}$								
15.156	1179	7.65	M_2 c $n_{2 \text{ Eck}}$ $n_{2 \text{ th}}$					307 3.7 111 111		272 3.6 230 191	

$M \dots$ [Nm]
 $n \dots$ [min^{-1}]
 $J \dots$ [kgcm^2]

$P \dots$ [kW]
 $I \dots$ [A]
 i [-]
 c [-]

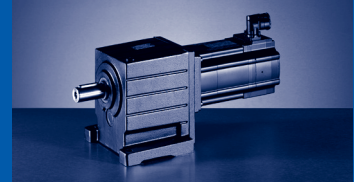

$M_{2GN} \leq 1582 \text{ Nm}$

195C17	195C23	195C35	195C42	21XC17	21XC25	21XC35	21XC42	GST09-2A			
...F10	...S00	...F10	...S00	...F10	...S00	...F10	...S00	M_1	J_G	M_{2GN}	i
36.3	16.3	36	12	61.4	24.6	55	17	n_1			
1700	2340	3510	4150	1710	2490	3520	4160	I_{M400}			
13.9	8.2	28.7	14	22.5	13.5	42.5	19.8	P_N			
6.4	4	13.2	5.2	11	6.4	20.3	7.4	J_M			
72.12	72.12	72.04	72.12	180.04	180.04	180.04	180.04	M_2			
274		274		472	184	424		c	11	1133	8.027
3.8		3		2.3	5	2		$n_{2 \text{ Eck}}$			
212		437		213	310	439		$n_{2 \text{ th}}$			
212		305		213	251	251		M_2			
								c	15.2	1037	9.01
								$n_{2 \text{ Eck}}$			
								$n_{2 \text{ th}}$			
309		309		531	207	477	142	M_2			
3.4		2.7		2	4.4	1.8	5.4	c	15.2	1128	9.01
189		390		190	276	391	462	$n_{2 \text{ Eck}}$			
189		223		190	223	194	223	$n_{2 \text{ th}}$			
								M_2			
								c	12.4	1063	10.267
								$n_{2 \text{ Eck}}$			
								$n_{2 \text{ th}}$			
354		353		606	237	544	162	M_2			
3.1		2.5		1.8	4.1	1.6	5	c	12.4	1178	10.267
166		342		167	243	343	405	$n_{2 \text{ Eck}}$			
166		210		167	196	177	196	$n_{2 \text{ th}}$			
403	176	402		690	271	620	186	M_2			
2.8	5.6	2.2		1.7	3.7	1.5	4.5	c	12.1	1206	11.667
146	201	301		147	213	302	357	$n_{2 \text{ Eck}}$			
146	201	180		147	173	147	173	$n_{2 \text{ th}}$			
								M_2			
								c	9.79	958	12.362
								$n_{2 \text{ Eck}}$			
								$n_{2 \text{ th}}$			
								M_2			
								c	9.79	1121	12.362
								$n_{2 \text{ Eck}}$			
								$n_{2 \text{ th}}$			
427	186	427		732	287	657	197	M_2			
2.8	5.5	2.2		1.6	3.6	1.4	4.4	c	9.79	1253	12.362
138	189	284		138	201	285	337	$n_{2 \text{ Eck}}$			
138	189	192		138	163	155	163	$n_{2 \text{ th}}$			
								M_2			
								c	9.53	1088	14.048
								$n_{2 \text{ Eck}}$			
								$n_{2 \text{ th}}$			
								M_2			
								c	9.53	1274	14.048
								$n_{2 \text{ Eck}}$			
								$n_{2 \text{ th}}$			
487	213	486	156	833	328	747	225	M_2			
2.5	5	2	5.6	1.5	3.2	1.3	3.9	c	9.53	1283	14.048
121	167	250	295	122	177	251	296	$n_{2 \text{ Eck}}$			
121	167	165	174	122	143	129	143	$n_{2 \text{ th}}$			
								M_2			
								c	7.65	1179	15.156
								$n_{2 \text{ Eck}}$			
								$n_{2 \text{ th}}$			

M ... [Nm]
n ... [min⁻¹]
J ... [kgcm²]

P ... [kW]
I ... [A]
i [-]
c [-]

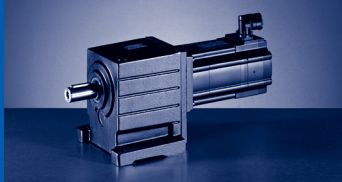

GST [Nm]

GST□□-□A (MCA)

$M_{2GN} \leq 1582 \text{ Nm}$

GST09-2A				14LC16	14LC20	14LC35	14LC41	17NC17	17NC23	17NC35	17NC41
				...F10	...S00	...F10	...S00	...F10	...S00	...F10	...S00
i	M_{2GN}	J_G	M_1	12	6.7	10.8	5.4	21.5	10.8	19	9.5
			n_1	1635	2000	3455	4100	1680	2300	3480	4110
			I_{M400}	4.8	3.3	9.1	5.8	8.5	5.5	15.8	10.2
			P_N	2.1	1.4	3.9	2.3	3.8	2.6	6.9	4.1
			J_M	19.32	19.24	19.24	19.24	36.04	36.04	36.04	36.04
15.156	1340	7.65	M_2								
			c								
			$n_{2 \text{ Eck}}$								
			$n_{2 \text{ th}}$								
17.222	1340	7.49	M_2					349		309	
			c					3.7		3.6	
			$n_{2 \text{ Eck}}$					98		202	
			$n_{2 \text{ th}}$					98		168	
17.222	1373	7.49	M_2								
			c								
			$n_{2 \text{ Eck}}$								
			$n_{2 \text{ th}}$								
20.533	1068	4.5	M_2	231		208					
			c	4.5		4.3					
			$n_{2 \text{ Eck}}$	80		168					
			$n_{2 \text{ th}}$	80		168					
20.533	1251	4.5	M_2					420	205	371	181
			c					2.9	5.7	2.8	5.4
			$n_{2 \text{ Eck}}$					82	112	170	200
			$n_{2 \text{ th}}$					82	112	152	152
20.533	1484	4.5	M_2								
			c								
			$n_{2 \text{ Eck}}$								
			$n_{2 \text{ th}}$								
23.333	1214	4.41	M_2	262		236					
			c	4.5		4.3					
			$n_{2 \text{ Eck}}$	70		148					
			$n_{2 \text{ th}}$	70		148					
23.333	1421	4.41	M_2					477	233	422	205
			c					2.9	5.7	2.8	5.4
			$n_{2 \text{ Eck}}$					72	99	149	176
			$n_{2 \text{ th}}$					72	99	133	133
23.333	1508	4.41	M_2								
			c								
			$n_{2 \text{ Eck}}$								
			$n_{2 \text{ th}}$								
24.933	1107	3.38	M_2	282		254					
			c	3.8		3.7					
			$n_{2 \text{ Eck}}$	66		139					
			$n_{2 \text{ th}}$	66		139					
24.933	1296	3.38	M_2					512	251	453	221
			c					2.5	4.9	2.4	4.6
			$n_{2 \text{ Eck}}$					67	92	140	165
			$n_{2 \text{ th}}$					67	92	125	125
24.933	1582	3.38	M_2								
			c								
			$n_{2 \text{ Eck}}$								
			$n_{2 \text{ th}}$								
28.333	1258	3.32	M_2	320		289					
			c	3.8		3.7					
			$n_{2 \text{ Eck}}$	58		122					
			$n_{2 \text{ th}}$	58		122					

$M \dots$ [Nm]
 $n \dots$ [min^{-1}]
 $J \dots$ [kgcm^2]

$P \dots$ [kW]
 $I \dots$ [A]
 i [-]
 c [-]



$M_{2GN} \leq 1582 \text{ Nm}$

195C17	195C23	195C35	195C42	21XC17	21XC25	21XC35	21XC42	GST09-2A			
...F10	...S00	...F10	...S00	...F10	...S00	...F10	...S00	M_1	J_G	M_{2GN}	i
36.3	16.3	36	12	61.4	24.6	55	17	n_1			
1700	2340	3510	4150	1710	2490	3520	4160	I_{M400}			
13.9	8.2	28.7	14	22.5	13.5	42.5	19.8	P_N			
6.4	4	13.2	5.2	11	6.4	20.3	7.4	J_M			
72.12	72.12	72.04	72.12	180.04	180.04	180.04	180.04	M_2			
525	229	523		898	352	805	241	c	7.65	1340	15.156
2.5	5.5	2.2		1.5	3.6	1.4	4.3	$n_{2 \text{ Eck}}$			
112	154	232		113	164	232	275	$n_{2 \text{ th}}$			
112	154	162		113	133	133	133	M_2			
								c	7.49	1340	17.222
								$n_{2 \text{ Eck}}$			
								$n_{2 \text{ th}}$			
599	261	596	191	1022	402	916	276	M_2			
2.3	4.9	2	5.5	1.3	3.2	1.3	3.9	c	7.49	1373	17.222
99	136	204	241	99	145	204	242	$n_{2 \text{ Eck}}$			
99	136	142	142	99	117	117	117	$n_{2 \text{ th}}$			
								M_2			
								c	4.5	1068	20.533
								$n_{2 \text{ Eck}}$			
								$n_{2 \text{ th}}$			
								M_2			
								c	4.5	1251	20.533
								$n_{2 \text{ Eck}}$			
								$n_{2 \text{ th}}$			
715	313	711	229					M_2			
2.1	4.5	1.8	5					c	4.5	1484	20.533
83	114	171	202					$n_{2 \text{ Eck}}$			
83	114	119	119					$n_{2 \text{ th}}$			
								M_2			
								c	4.41	1214	23.333
								$n_{2 \text{ Eck}}$			
								$n_{2 \text{ th}}$			
								M_2			
								c	4.41	1421	23.333
								$n_{2 \text{ Eck}}$			
								$n_{2 \text{ th}}$			
815	358	810	262					M_2			
1.8	4	1.6	4.5					c	4.41	1508	23.333
73	100	150	178					$n_{2 \text{ Eck}}$			
73	100	105	105					$n_{2 \text{ th}}$			
								M_2			
								c	3.38	1107	24.933
								$n_{2 \text{ Eck}}$			
								$n_{2 \text{ th}}$			
								M_2			
								c	3.38	1296	24.933
								$n_{2 \text{ Eck}}$			
								$n_{2 \text{ th}}$			
871	382	866	280					M_2			
1.8	3.9	1.6	4.4					c	3.38	1582	24.933
68	94	141	166					$n_{2 \text{ Eck}}$			
68	94	98	98					$n_{2 \text{ th}}$			
								M_2			
								c	3.32	1258	28.333
								$n_{2 \text{ Eck}}$			
								$n_{2 \text{ th}}$			

M ... [Nm]
n ... [min⁻¹]
J ... [kgcm²]

P ... [kW]
I ... [A]
i [-]
c [-]

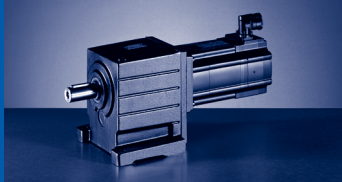

GST [Nm]

GST□□-□A (MCA)

$M_{2GN} \leq 1582 \text{ Nm}$

GST09-2A				14LC16	14LC20	14LC35	14LC41	17NC17	17NC23	17NC35	17NC41	
				...F10	...S00	...F10	...S00	...F10	...S00	...F10	...S00	
i	M_{2GN}	J_G	M_1	12	6.7	10.8	5.4	21.5	10.8	19	9.5	
			n_1	1635	2000	3455	4100	1680	2300	3480	4110	
			I_{M400}	4.8	3.3	9.1	5.8	8.5	5.5	15.8	10.2	
			P_N	2.1	1.4	3.9	2.3	3.8	2.6	6.9	4.1	
			J_M	19.32	19.24	19.24	19.24	36.04	36.04	36.04	36.04	
28.333	1472	3.32	M_2					582	285	515	252	
			c					2.5	4.9	2.4	4.6	
			$n_{2 \text{ Eck}}$						59	81	123	145
			$n_{2 \text{ th}}$						59	81	110	110
28.333	1519	3.32	M_2									
			c									
			$n_{2 \text{ Eck}}$									
			$n_{2 \text{ th}}$									
32.267	1147	2.25	M_2	368	200	331	161					
			c	3.1	5.5	2.9	5.5					
			$n_{2 \text{ Eck}}$	51	62	107	127					
			$n_{2 \text{ th}}$	51	62	107	111					
32.267	1343	2.25	M_2					666	328	589	289	
			c						2	3.9	1.9	3.7
			$n_{2 \text{ Eck}}$						52	71	108	127
			$n_{2 \text{ th}}$						52	71	96	96
36.667	1304	2.21	M_2	418	227	377	183					
			c	3.1	5.5	2.9	5.5					
			$n_{2 \text{ Eck}}$	45	55	94	112					
			$n_{2 \text{ th}}$	45	55	94	98					
36.667	1526	2.21	M_2					757	373	669	329	
			c						2	3.9	1.9	3.7
			$n_{2 \text{ Eck}}$						46	63	95	112
			$n_{2 \text{ th}}$						46	63	85	85
39.16	1166	1.64	M_2	449	245	404	198					
			c	2.6	4.6	2.4	4.6					
			$n_{2 \text{ Eck}}$	42	51	88	105					
			$n_{2 \text{ th}}$	42	51	88	92					
39.16	1364	1.64	M_2					811	401	717	353	
			c						1.7	3.3	1.6	3.1
			$n_{2 \text{ Eck}}$						43	59	89	105
			$n_{2 \text{ th}}$						43	59	79	79
44.5	1324	1.62	M_2	510	279	458	223					
			c	2.6	4.6	2.7	5.1					
			$n_{2 \text{ Eck}}$	37	45	78	92					
			$n_{2 \text{ th}}$	37	45	78	81					
44.5	1546	1.62	M_2					922	455	814	400	
			c						1.7	3.3	1.8	3.4
			$n_{2 \text{ Eck}}$						38	52	78	92
			$n_{2 \text{ th}}$						38	52	70	70
49.5	1184	1.12	M_2	570	313	512	251					
			c	2.1	3.7	2.2	4.1					
			$n_{2 \text{ Eck}}$	33	40	70	83					
			$n_{2 \text{ th}}$	33	40	70	73					
56.25	1345	1.1	M_2	648	356	582	285					
			c	2.1	3.7	2.2	4.1					
			$n_{2 \text{ Eck}}$	29	36	61	73					
			$n_{2 \text{ th}}$	29	36	61	64					

$M \dots$ [Nm]
 $n \dots$ [min^{-1}]
 $J \dots$ [kgcm^2]

$P \dots$ [kW]
 $I \dots$ [A]
 i [-]
 c [-]

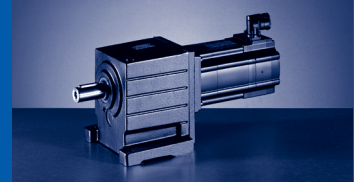

$M_{2GN} \leq 1582 \text{ Nm}$

195C17	195C23	195C35	195C42	21XC17	21XC25	21XC35	21XC42	GST09-2A			
...F10	...S00	...F10	...S00	...F10	...S00	...F10	...S00	M_1	J_G	M_{2GN}	i
36.3	16.3	36	12	61.4	24.6	55	17	n_1			
1700	2340	3510	4150	1710	2490	3520	4160	I_{M400}			
13.9	8.2	28.7	14	22.5	13.5	42.5	19.8	P_N			
6.4	4	13.2	5.2	11	6.4	20.3	7.4	J_M			
72.12	72.12	72.04	72.12	180.04	180.04	180.04	180.04	M_2 c			
								n_2 Eck	3.32	1472	28.333
								n_2 th			
993	437	986	321					M_2 c			
1.5	3.3	1.3	3.7					n_2 Eck	3.32	1519	28.333
60	83	124	147					n_2 th			
60	83	86	86					M_2 c			
								n_2 Eck	2.25	1147	32.267
								n_2 th			
								M_2 c			
								n_2 Eck	2.25	1343	32.267
								n_2 th			
								M_2 c			
								n_2 Eck	2.21	1304	36.667
								n_2 th			
								M_2 c			
								n_2 Eck	2.21	1526	36.667
								n_2 th			
								M_2 c			
								n_2 Eck	1.64	1166	39.16
								n_2 th			
								M_2 c			
								n_2 Eck	1.64	1364	39.16
								n_2 th			
								M_2 c			
								n_2 Eck	1.62	1324	44.5
								n_2 th			
								M_2 c			
								n_2 Eck	1.62	1546	44.5
								n_2 th			
								M_2 c			
								n_2 Eck	1.12	1184	49.5
								n_2 th			
								M_2 c			
								n_2 Eck	1.1	1345	56.25
								n_2 th			

M ... [Nm]
n ... [min⁻¹]
J ... [kgcm²]

P ... [kW]
I ... [A]
i [-]
c [-]

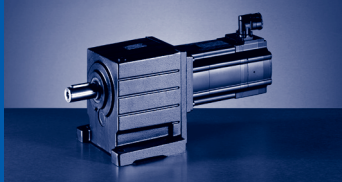

GST [Nm]

GST□□-□A (MCA)

$M_{2GN} \leq 1623 \text{ Nm}$

GST09-3A				10IC40	13IC34	13IC41	14LC16	14LC20	14LC35	14LC41	17NC17	17NC23	17NC35	17NC41
				...S00	...F10	...S00	...F10	...S00	...F10	...S00	...F10	...S00	...F10	...S00
i	M_{2GN}	J_G	M_1	2	6.3	4	12	6.7	10.8	5.4	21.5	10.8	19	9.5
			n_1	3950	3410	4050	1635	2000	3455	4100	1680	2300	3480	4110
			I_{M400}	2.4	6	4.4	4.8	3.3	9.1	5.8	8.5	5.5	15.8	10.2
			P_N	0.8	2.2	1.7	2.1	1.4	3.9	2.3	3.8	2.6	6.9	4.1
			J_M	2.44	8.34	8.34	19.32	19.24	19.24	19.24	36.04	36.04	36.04	36.04
40.136	1344	2.14	M_2		232		451	246	406	198	819	405	724	357
			c		4.8		2.9	5.2	2.8	5.3	1.6	3.2	1.6	3
			$n_{2 \text{ Eck}}$		85		41	50	86	102	42	57	87	102
			$n_{2 \text{ th}}$		85		41	50	86	89	42	57	78	78
43.267	1290	1.55	M_2		250		488	266	438	213	885	438	781	385
			c		4.7		2.6	4.7	2.8	5.2	1.5	2.9	1.6	3
			$n_{2 \text{ Eck}}$		79		38	46	80	95	39	53	80	95
			$n_{2 \text{ th}}$		79		38	46	80	83	39	53	72	72
49.167	1466	1.53	M_2		284		554	303	498	243	1005	497	888	437
			c		4.7		2.6	4.7	2.8	5.2	1.5	2.9	1.6	3
			$n_{2 \text{ Eck}}$		69		33	41	70	83	34	47	71	84
			$n_{2 \text{ th}}$		69		33	41	70	73	34	47	63	63
53.044	1379	1.38	M_2		309		600	329	539	264	1087	539	960	474
			c		4.1		2.3	4.1	2.4	4.5	1.3	2.5	1.4	2.6
			$n_{2 \text{ Eck}}$		64		31	38	65	77	32	43	66	78
			$n_{2 \text{ th}}$		64		31	38	65	68	32	43	59	59
60.278	1565	1.37	M_2		351		682	374	613	300	1235	612	1090	538
			c		4.1		2.3	4.1	2.4	4.5	1.3	2.5	1.4	2.6
			$n_{2 \text{ Eck}}$		57		27	33	57	68	28	38	58	68
			$n_{2 \text{ th}}$		57		27	33	57	60	28	38	52	52
71.867	1477	1.17	M_2		422	264	817	450	735	361	1477	734	1304	645
			c		3.3	4.9	1.8	3.2	1.9	3.6	1	2	1.1	2
			$n_{2 \text{ Eck}}$		48	56	23	28	48	57	23	32	48	57
			$n_{2 \text{ th}}$		47	56	23	28	48	50	23	32	43	43
81.667	1584	1.16	M_2		481	300	930	512	836	411		835	1483	734
			c		3.1	4.6	1.7	3	1.8	3.4		1.9	1	1.9
			$n_{2 \text{ Eck}}$		42	50	20	25	42	50		28	43	50
			$n_{2 \text{ th}}$		42	50	20	24	42	44		28	38	38
93.541	1613	0.71	M_2		553	346	1067	588	959	473				
			c		2.7	4.1	1.5	2.7	1.6	3				
			$n_{2 \text{ Eck}}$		37	43	18	21	37	44				
			$n_{2 \text{ th}}$		36	43	17	21	37	38				
99.167	1596	1.07	M_2		587	368	1132	625	1018	502		1018		895
			c		2.6	3.8	1.4	2.5	1.5	2.8		1.6		1.6
			$n_{2 \text{ Eck}}$		34	41	17	20	35	41		23		42
			$n_{2 \text{ th}}$		34	41	16	20	35	36		23		31
113.585	1613	0.65	M_2		675	423	1299	718	1169	577				
			c		2.3	3.4	1.2	2.2	1.3	2.5				
			$n_{2 \text{ Eck}}$		30	36	14	18	30	36				
			$n_{2 \text{ th}}$		30	36	14	18	30	32				
129.074	1612	0.65	M_2	234	769	483	1479	818	1330	658				
			c	6	2	3	1.1	2	1.2	2.2				
			$n_{2 \text{ Eck}}$	31	26	31	13	16	27	32				
			$n_{2 \text{ th}}$	31	26	31	13	15	27	28				
141.289	1613	0.46	M_2	257	843	530		897	1457	722				
			c	5.5	1.8	2.7		1.8	1.1	2				
			$n_{2 \text{ Eck}}$	28	24	29		14	25	29				
			$n_{2 \text{ th}}$	28	24	29		14	24	25				
160.556	1623	0.46	M_2	295	961	605		1022		822				
			c	4.8	1.6	2.4		1.6		1.8				
			$n_{2 \text{ Eck}}$	25	21	25		13		26				
			$n_{2 \text{ th}}$	25	21	25		12		22				

$M \dots$ [Nm]
 $n \dots$ [min^{-1}]
 $J \dots$ [kgcm^2]

$P \dots$ [kW]
 $I \dots$ [A]
 $i \dots$ [-]
 $c \dots$ [-]

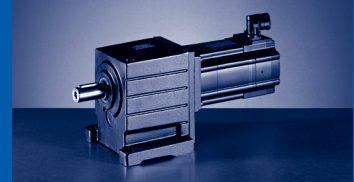

$M_{2GN} \leq 1623 \text{ Nm}$

GST09-3A				10IC40	13IC34	13IC41	14LC16	14LC20	14LC35	14LC41	17NC17	17NC23	17NC35	17NC41	
				...S00	...F10	...S00	...F10	...S00	...F10	...S00	...F10	...S00	...F10	...S00	
i	M_{2GN}	J_G	M_1	2	6.3	4	12	6.7	10.8	5.4	21.5	10.8	19	9.5	
			n_1	3950	3410	4050	1635	2000	3455	4100	1680	2300	3480	4110	
			I_{M400}	2.4	6	4.4	4.8	3.3	9.1	5.8	8.5	5.5	15.8	10.2	
			P_N	0.8	2.2	1.7	2.1	1.4	3.9	2.3	3.8	2.6	6.9	4.1	
			J_M	2.44	8.34	8.34	19.32	19.24	19.24	19.24	36.04	36.04	36.04	36.04	
182.844	1613	0.3	M_2	338	1096	691									
			c	4.2	1.4	2.1									
			$n_{2 \text{ Eck}}$	22	19	22									
			$n_{2 \text{ th}}$	22	19	22									
207.778	1623	0.3	M_2	386	1248	787									
			c	3.7	1.2	1.9									
			$n_{2 \text{ Eck}}$	19	16	20									
			$n_{2 \text{ th}}$	19	16	19									
236.622	1613	0.28	M_2	442	1423	899									
			c	3.3	1.1	1.6									
			$n_{2 \text{ Eck}}$	17	14	17									
			$n_{2 \text{ th}}$	17	14	17									
252.167	1623	0.21	M_2	472	1518	959									
			c	3.1	1	1.5									
			$n_{2 \text{ Eck}}$	16	14	16									
			$n_{2 \text{ th}}$	16	14	16									
268.889	1623	0.28	M_2	504		1023									
			c	2.9		1.4									
			$n_{2 \text{ Eck}}$	15		15									
			$n_{2 \text{ th}}$	15		15									
326.333	1623	0.2	M_2	615		1245									
			c	2.4		1.2									
			$n_{2 \text{ Eck}}$	12		12									
			$n_{2 \text{ th}}$	12		12									
363	1613	0.26	M_2	686											
			c	2.1											
			$n_{2 \text{ Eck}}$	11											
			$n_{2 \text{ th}}$	11											
412.5	1623	0.18	M_2	781											
			c	1.9											
			$n_{2 \text{ Eck}}$	10											
			$n_{2 \text{ th}}$	10											

M ... [Nm]
n ... [min^{-1}]
J ... [kgcm^2]

P ... [kW]
I ... [A]
i [-]
c [-]

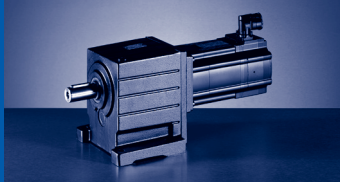

GST [Nm]

GST□□-□A (MCA)

$M_{2GN} \leq 2933 \text{ Nm}$

GST11-2A				14LC16	14LC20	14LC35	14LC41	17NC17	17NC23	17NC35	17NC41
				...F10	...S00	...F10	...S00	...F10	...S00	...F10	...S00
i	M_{2GN}	J_G	M_1	12	6.7	10.8	5.4	21.5	10.8	19	9.5
			n_1	1635	2000	3455	4100	1680	2300	3480	4110
			I_{M400}	4.8	3.3	9.1	5.8	8.5	5.5	15.8	10.2
			P_N	2.1	1.4	3.9	2.3	3.8	2.6	6.9	4.1
			J_M	19.32	19.24	19.24	19.24	36.04	36.04	36.04	36.04
4.056	1490	82.2	M_2 c $n_{2 \text{ Eck}}$ $n_{2 \text{ th}}$								
4.457	1606	79	M_2 c $n_{2 \text{ Eck}}$ $n_{2 \text{ th}}$								
5.324	1594	55.4	M_2 c $n_{2 \text{ Eck}}$ $n_{2 \text{ th}}$								
5.85	1772	53.5	M_2 c $n_{2 \text{ Eck}}$ $n_{2 \text{ th}}$								
6.4	1549	45.7	M_2 c $n_{2 \text{ Eck}}$ $n_{2 \text{ th}}$								
6.4	1801	45.7	M_2 c $n_{2 \text{ Eck}}$ $n_{2 \text{ th}}$								
6.864	2065	67.5	M_2 c $n_{2 \text{ Eck}}$ $n_{2 \text{ th}}$								
7.8	2114	65.1	M_2 c $n_{2 \text{ Eck}}$ $n_{2 \text{ th}}$								
9.01	2259	46.8	M_2 c $n_{2 \text{ Eck}}$ $n_{2 \text{ th}}$								
9.856	2325	40.2	M_2 c $n_{2 \text{ Eck}}$ $n_{2 \text{ th}}$								
11.2	2380	39	M_2 c $n_{2 \text{ Eck}}$ $n_{2 \text{ th}}$								
12.571	1414	29.4	M_2 c $n_{2 \text{ Eck}}$ $n_{2 \text{ th}}$					251 5.2 134 134		223 4.6 277 180	
12.571	2520	29.4	M_2 c $n_{2 \text{ Eck}}$ $n_{2 \text{ th}}$								

$M \dots$ [Nm]
 $n \dots$ [min^{-1}]
 $J \dots$ [kgcm^2]

$P \dots$ [kW]
 $I \dots$ [A]
 i [-]
 c [-]

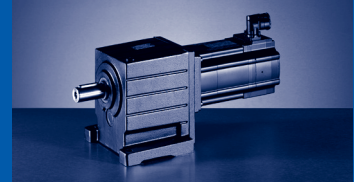

$M_{2GN} \leq 2933 \text{ Nm}$

195C17	195C23	195C35	195C42	21XC17	21XC25	21XC35	21XC42	GST11-2A			
...F10	...S00	...F10	...S00	...F10	...S00	...F10	...S00	M_1	J_G	M_{2GN}	i
36.3	16.3	36	12	61.4	24.6	55	17	n_1			
1700	2340	3510	4150	1710	2490	3520	4160	I_{M400}			
13.9	8.2	28.7	14	22.5	13.5	42.5	19.8	P_N			
6.4	4	13.2	5.2	11	6.4	20.3	7.4	J_M			
72.12	72.12	72.04	72.12	180.04	180.04	180.04	180.04	M_2			
				229		207		c			
				5.9		5.2		$n_{2 \text{ Eck}}$	82.2	1490	4.056
				422		868		$n_{2 \text{ th}}$			
				422		421		M_2			
				252		228		c			
				5.8		5.1		$n_{2 \text{ Eck}}$	79	1606	4.457
				384		790		$n_{2 \text{ th}}$			
				384		382		M_2			
				305		275		c			
				4.8		4.2		$n_{2 \text{ Eck}}$	55.4	1594	5.324
				321		661		$n_{2 \text{ th}}$			
				321		356		M_2			
				335		302		c			
				4.9		4.3		$n_{2 \text{ Eck}}$	53.5	1772	5.85
				292		602		$n_{2 \text{ th}}$			
				292		325		M_2			
		214						c			
		5.2						$n_{2 \text{ Eck}}$	45.7	1549	6.4
		548						$n_{2 \text{ th}}$			
		320						M_2			
				367		331		c			
				4.5		4		$n_{2 \text{ Eck}}$	45.7	1801	6.4
				267		550		$n_{2 \text{ th}}$			
				267		302		M_2			
				393		354		c			
				4.8		4.2		$n_{2 \text{ Eck}}$	67.5	2065	6.864
				249		513		$n_{2 \text{ th}}$			
				245		238		M_2			
				449		404		c			
				4.4		3.8		$n_{2 \text{ Eck}}$	65.1	2114	7.8
				219		451		$n_{2 \text{ th}}$			
				211		204		M_2			
				520		468		c			
				4		3.5		$n_{2 \text{ Eck}}$	46.8	2259	9.01
				190		391		$n_{2 \text{ th}}$			
				190		202		M_2			
		330		570		513		c			
		5.1		3.8		3.3		$n_{2 \text{ Eck}}$	40.2	2325	9.856
		356		174		357		$n_{2 \text{ th}}$			
		207		174		188		M_2			
375		377		651		585		c			
5.8		4.6		3.4		3		$n_{2 \text{ Eck}}$	39	2380	11.2
152		313		153		314		$n_{2 \text{ th}}$			
152		178		153		161		M_2			
								c			
								$n_{2 \text{ Eck}}$	29.4	1414	12.571
								$n_{2 \text{ th}}$			
422		424		732		658		M_2			
5.5		4.3		3.2		2.8		c			
135		279		136		280		$n_{2 \text{ Eck}}$	29.4	2520	12.571
135		178		136		160		$n_{2 \text{ th}}$			

M ... [Nm]
n ... [min⁻¹]
J ... [kgcm²]

P ... [kW]
I ... [A]
i [-]
c [-]

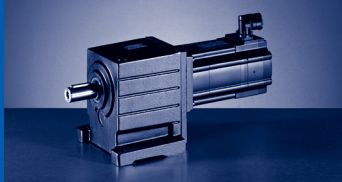

GST [Nm]

GST□□-□A (MCA)

$M_{2GN} \leq 2933 \text{ Nm}$

GST11-2A				14LC16	14LC20	14LC35	14LC41	17NC17	17NC23	17NC35	17NC41
				...F10	...S00	...F10	...S00	...F10	...S00	...F10	...S00
i	M_{2GN}	J_G	M_1								
			n_1	12	6.7	10.8	5.4	21.5	10.8	19	9.5
			I_{M400}	1635	2000	3455	4100	1680	2300	3480	4110
			P_N	4.8	3.3	9.1	5.8	8.5	5.5	15.8	10.2
			J_M	2.1	1.4	3.9	2.3	3.8	2.6	6.9	4.1
			M_2	19.32	19.24	19.24	19.24	36.04	36.04	36.04	36.04
			c					285		254	
14.286	1607	28.7	$n_{2 \text{ Eck}}$					5.2		4.6	
			$n_{2 \text{ th}}$					118		244	
								118		159	
14.286	2579	28.7	M_2								
			c								
			$n_{2 \text{ Eck}}$								
			$n_{2 \text{ th}}$								
15.4	2695	23	M_2								
			c								
			$n_{2 \text{ Eck}}$								
			$n_{2 \text{ th}}$								
17.5	2758	22.5	M_2								
			c								
			$n_{2 \text{ Eck}}$								
			$n_{2 \text{ th}}$								
20.289	1570	14.3	M_2					411		364	
			c					3.7		3.6	
			$n_{2 \text{ Eck}}$					83		172	
			$n_{2 \text{ th}}$					83		143	
20.289	2756	14.3	M_2								
			c								
			$n_{2 \text{ Eck}}$								
			$n_{2 \text{ th}}$								
23.056	1784	14.1	M_2					468		414	
			c					3.7		3.6	
			$n_{2 \text{ Eck}}$					73		151	
			$n_{2 \text{ th}}$					73		125	
23.056	2913	14.1	M_2								
			c								
			$n_{2 \text{ Eck}}$								
			$n_{2 \text{ th}}$								
24.933	1616	10.6	M_2					509		450	219
			c					3.1		3	5.7
			$n_{2 \text{ Eck}}$					67		140	165
			$n_{2 \text{ th}}$					67		125	125
24.933	2777	10.6	M_2								
			c								
			$n_{2 \text{ Eck}}$								
			$n_{2 \text{ th}}$								
28.333	1836	10.4	M_2					578		511	248
			c					3.1		3	5.7
			$n_{2 \text{ Eck}}$					59		123	145
			$n_{2 \text{ th}}$					59		110	110
28.333	2933	10.4	M_2								
			c								
			$n_{2 \text{ Eck}}$								
			$n_{2 \text{ th}}$								
32.267	1430	7.04	M_2	365		329					
			c	3.8		3.6					
			$n_{2 \text{ Eck}}$	51		107					
			$n_{2 \text{ th}}$	51		107					

$M \dots$ [Nm]
 $n \dots$ [min^{-1}]
 $J \dots$ [kgcm^2]

$P \dots$ [kW]
 $I \dots$ [A]
 i [-]
 c [-]



$M_{2GN} \leq 2933 \text{ Nm}$

195C17	195C23	195C35	195C42	21XC17	21XC25	21XC35	21XC42	GST11-2A			
...F10	...S00	...F10	...S00	...F10	...S00	...F10	...S00	M_1	J_G	M_{2GN}	i
36.3	16.3	36	12	61.4	24.6	55	17	n_1			
1700	2340	3510	4150	1710	2490	3520	4160	I_{M400}			
13.9	8.2	28.7	14	22.5	13.5	42.5	19.8	P_N			
6.4	4	13.2	5.2	11	6.4	20.3	7.4	J_M			
72.12	72.12	72.04	72.12	180.04	180.04	180.04	180.04	M_2 c			
								n_2 Eck	28.7	1607	14.286
								n_2 th			
483		484		834		750		M_2 c			
4.9		3.9		2.9		2.6		n_2 Eck	28.7	2579	14.286
119		246		120		246		n_2 th			
119		153		120		139		M_2 c			
520		520		899		807		n_2 Eck	23	2695	15.4
5		4.3		2.9		2.8		n_2 th			
110		228		111		229		M_2 c			
110		159		111		131		n_2 Eck	22.5	2758	17.5
594		593		1025		919		n_2 th			
4.5		3.9		2.7		2.5		M_2 c			
97		201		98		201		n_2 Eck	14.3	1570	20.289
97		140		98		115		n_2 th			
								M_2 c			
								n_2 Eck	14.3	2756	20.289
								n_2 th			
694		692		1193	462	1070		M_2 c			
3.9		3.3		2.3	5.5	2.2		n_2 Eck	14.1	1784	23.056
84		173		84	123	174		n_2 th			
84		121		84	99	99		M_2 c			
								n_2 Eck	14.1	2913	23.056
								n_2 th			
790		788		1358	527	1217		M_2 c			
3.6		3.1		2.1	5.1	2		n_2 Eck	10.6	1616	24.933
74		152		74	108	153		n_2 th			
74		106		74	87	87		M_2 c			
								n_2 Eck	10.6	2777	24.933
								n_2 th			
859		855		1472	574	1320	392	M_2 c			
3.2		2.7		1.9	4.5	1.8	5.5	n_2 Eck	10.4	1836	28.333
68		141		69	100	141	167	n_2 th			
68		98		69	81	81	81	M_2 c			
								n_2 Eck	10.4	2933	28.333
								n_2 th			
978		974		1675	654	1502	448	M_2 c			
2.9		2.5		1.7	4.2	1.7	5.1	n_2 Eck	7.04	1430	32.267
60		124		60	88	124	147	n_2 th			
60		86		60	71	71	71	M_2 c			
								n_2 Eck			
								n_2 th			

M ... [Nm]
n ... [min⁻¹]
J ... [kgcm²]

P ... [kW]
I ... [A]
i [-]
c [-]

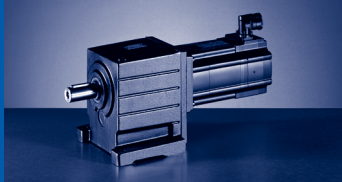

GST [Nm]

GST□□-□A (MCA)

$M_{2GN} \leq 2933 \text{ Nm}$

GST11-2A				14LC16	14LC20	14LC35	14LC41	17NC17	17NC23	17NC35	17NC41
				...F10	...S00	...F10	...S00	...F10	...S00	...F10	...S00
i	M_{2GN}	J_G	M_1	12	6.7	10.8	5.4	21.5	10.8	19	9.5
			n_1	1635	2000	3455	4100	1680	2300	3480	4110
			I_{M400}	4.8	3.3	9.1	5.8	8.5	5.5	15.8	10.2
			P_N	2.1	1.4	3.9	2.3	3.8	2.6	6.9	4.1
			J_M	19.32	19.24	19.24	19.24	36.04	36.04	36.04	36.04
32.267	1674	7.04	M_2					663	325	586	286
			c				2.5	4.9	2.4	4.6	
			$n_{2 \text{ Eck}}$				52	71	108	127	
			$n_{2 \text{ th}}$				52	71	96	96	
32.267	2818	7.04	M_2								
			c								
			$n_{2 \text{ Eck}}$								
			$n_{2 \text{ th}}$								
36.667	1624	6.93	M_2	415		374					
			c	3.8		3.6					
			$n_{2 \text{ Eck}}$	45		94					
			$n_{2 \text{ th}}$	45		94					
36.667	1902	6.93	M_2					753	369	666	326
			c					2.5	4.9	2.4	4.6
			$n_{2 \text{ Eck}}$					46	63	95	112
			$n_{2 \text{ th}}$					46	63	85	85
36.667	2933	6.93	M_2								
			c								
			$n_{2 \text{ Eck}}$								
			$n_{2 \text{ th}}$								
39.16	1452	5.15	M_2	446	242	402	195				
			c	3.2	5.7	3.1	5.8				
			$n_{2 \text{ Eck}}$	42	51	88	105				
			$n_{2 \text{ th}}$	42	51	88	92				
39.16	1701	5.15	M_2					808	397	714	350
			c					2.1	4.1	2	3.8
			$n_{2 \text{ Eck}}$					43	59	89	105
			$n_{2 \text{ th}}$					43	59	79	79
39.16	2826	5.15	M_2								
			c								
			$n_{2 \text{ Eck}}$								
			$n_{2 \text{ th}}$								
44.5	1650	5.08	M_2	506	275	455					
			c	3.2	5.7	3.4					
			$n_{2 \text{ Eck}}$	37	45	78					
			$n_{2 \text{ th}}$	37	45	78					
44.5	1933	5.08	M_2					918	451	810	396
			c					2.1	4.2	2.2	4.2
			$n_{2 \text{ Eck}}$					38	52	78	92
			$n_{2 \text{ th}}$					38	52	70	70
44.5	2933	5.08	M_2								
			c								
			$n_{2 \text{ Eck}}$								
			$n_{2 \text{ th}}$								
49.5	1476	3.52	M_2	567	310	510	248				
			c	2.6	4.6	2.7	5.1				
			$n_{2 \text{ Eck}}$	33	40	70	83				
			$n_{2 \text{ th}}$	33	40	70	73				
49.5	1728	3.52	M_2					1025	506	905	445
			c					1.7	3.3	1.8	3.4
			$n_{2 \text{ Eck}}$					34	47	70	83
			$n_{2 \text{ th}}$					34	46	63	63

$M \dots$ [Nm]
 $n \dots$ [min^{-1}]
 $J \dots$ [kgcm^2]

$P \dots$ [kW]
 $I \dots$ [A]
 i [-]
 c [-]

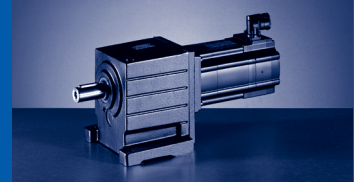

$M_{2GN} \leq 2933 \text{ Nm}$

195C17	195C23	195C35	195C42	21XC17	21XC25	21XC35	21XC42	GST11-2A			
...F10	...S00	...F10	...S00	...F10	...S00	...F10	...S00	M_1	J_G	M_{2GN}	i
36.3	16.3	36	12	61.4	24.6	55	17	n_1			
1700	2340	3510	4150	1710	2490	3520	4160	I_{M400}			
13.9	8.2	28.7	14	22.5	13.5	42.5	19.8	P_N			
6.4	4	13.2	5.2	11	6.4	20.3	7.4	J_M			
72.12	72.12	72.04	72.12	180.04	180.04	180.04	180.04	M_2 c n_{2Eck} n_{2th}	7.04	1674	32.267
1119	487	1114						M_2 c n_{2Eck} n_{2th}	7.04	2818	32.267
2.5	5.4	2.1						M_2 c n_{2Eck} n_{2th}	6.93	1624	36.667
53	73	109						M_2 c n_{2Eck} n_{2th}	6.93	1902	36.667
53	73	76						M_2 c n_{2Eck} n_{2th}	6.93	2933	36.667
1274	556	1268	407					M_2 c n_{2Eck} n_{2th}	5.15	1452	39.16
2.3	5	2	5.6					M_2 c n_{2Eck} n_{2th}	5.15	1701	39.16
46	64	96	113					M_2 c n_{2Eck} n_{2th}	5.15	2826	39.16
46	64	67	67					M_2 c n_{2Eck} n_{2th}	5.08	1650	44.5
1364	597	1357	437					M_2 c n_{2Eck} n_{2th}	5.08	1933	44.5
2.1	4.5	1.8	5					M_2 c n_{2Eck} n_{2th}	5.08	2933	44.5
43	60	90	106					M_2 c n_{2Eck} n_{2th}	3.52	1476	49.5
43	60	63	63					M_2 c n_{2Eck} n_{2th}	3.52	1728	49.5

$M \dots$ [Nm]
 $n \dots$ [min^{-1}]
 $J \dots$ [kgcm^2]

$P \dots$ [kW]
 $I \dots$ [A]
 i [-]
 c [-]

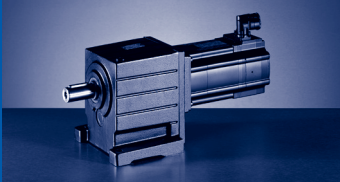

GST [Nm]

GST□□-□A (MCA)

$M_{2GN} \leq 2933 \text{ Nm}$

GST11-2A				14LC16	14LC20	14LC35	14LC41	17NC17	17NC23	17NC35	17NC41
				...F10	...S00	...F10	...S00	...F10	...S00	...F10	...S00
i	M_{2GN}	J_G	M_1	12	6.7	10.8	5.4	21.5	10.8	19	9.5
			n_1	1635	2000	3455	4100	1680	2300	3480	4110
			I_{M400}	4.8	3.3	9.1	5.8	8.5	5.5	15.8	10.2
			P_N	2.1	1.4	3.9	2.3	3.8	2.6	6.9	4.1
			J_M	19.32	19.24	19.24	19.24	36.04	36.04	36.04	36.04
56.25	1677	3.44	M_2	644	352	579	282				
			c	2.6	4.6	2.7	5.1				
			$n_{2 \text{ Eck}}$	29	36	61	73				
			$n_{2 \text{ th}}$	29	36	61	64				
56.25	1964	3.44	M_2					1165	575	1028	506
			c					1.7	3.3	1.8	3.4
			$n_{2 \text{ Eck}}$					30	41	62	73
			$n_{2 \text{ th}}$					30	41	55	55

M ... [Nm]
 n ... [min^{-1}]
 J ... [kgcm^2]

P ... [kW]
 I ... [A]
 i [-]
 c [-]

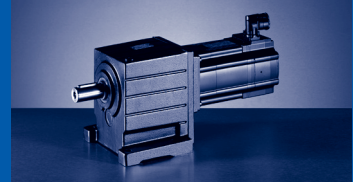

$M_{2GN} \leq 2933 \text{ Nm}$

195C17	195C23	195C35	195C42	21XC17	21XC25	21XC35	21XC42	GST11-2A			
...F10	...S00	...F10	...S00	...F10	...S00	...F10	...S00	M_1	J_G	M_{2GN}	i
36.3	16.3	36	12	61.4	24.6	55	17	n_1			
1700	2340	3510	4150	1710	2490	3520	4160	I_{M400}			
13.9	8.2	28.7	14	22.5	13.5	42.5	19.8	P_N			
6.4	4	13.2	5.2	11	6.4	20.3	7.4	J_M			
72.12	72.12	72.04	72.12	180.04	180.04	180.04	180.04	M_2 c n_{2Eck} n_{2th}	3.44	1677	56.25
								M_2 c n_{2Eck} n_{2th}	3.44	1964	56.25

M ... [Nm]
n ... [min⁻¹]
J ... [kgcm²]

P ... [kW]
I ... [A]
i [-]
c [-]

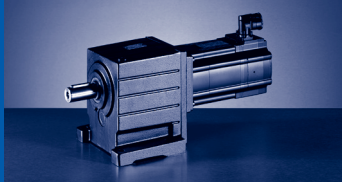

GST [Nm]

GST□□-□A (MCA)

$M_{2GN} \leq 2848 \text{ Nm}$

GST11-3A				10IC40	13IC34	13IC41	14LC16	14LC20	14LC35	14LC41
				...S00	...F10	...S00	...F10	...S00	...F10	...S00
i	M_{2GN}	J_G	M_1	2	6.3	4	12	6.7	10.8	5.4
			n_1	3950	3410	4050	1635	2000	3455	4100
			I_{M400}	2.4	6	4.4	4.8	3.3	9.1	5.8
			P_N	0.8	2.2	1.7	2.1	1.4	3.9	2.3
			J_M	2.44	8.34	8.34	19.32	19.24	19.24	19.24
40.816	1641	6.36	M_2		233					
			c		5.8					
			$n_{2 \text{ Eck}}$		84					
			$n_{2 \text{ th}}$		84					
40.816	2444	6.36	M_2				447		404	
			c				5.2		5	
			$n_{2 \text{ Eck}}$				40		85	
			$n_{2 \text{ th}}$				40		85	
40.816	2550	6.36	M_2							
			c							
			$n_{2 \text{ Eck}}$							
			$n_{2 \text{ th}}$							
44	2410	5.66	M_2				485		435	
			c				4.8		5.1	
			$n_{2 \text{ Eck}}$				37		79	
			$n_{2 \text{ th}}$				37		79	
50	2725	5.6	M_2				551		494	
			c				4.8		5	
			$n_{2 \text{ Eck}}$				33		69	
			$n_{2 \text{ th}}$				33		69	
57.968	2577	4.77	M_2				645		579	
			c				3.9		4.1	
			$n_{2 \text{ Eck}}$				28		60	
			$n_{2 \text{ th}}$				28		60	
61.25	2725	4.08	M_2				681		612	
			c				3.9		4.1	
			$n_{2 \text{ Eck}}$				27		56	
			$n_{2 \text{ th}}$				27		56	
71.011	2637	3.52	M_2				795	432	714	
			c				3.2	5.8	3.4	
			$n_{2 \text{ Eck}}$				23	28	49	
			$n_{2 \text{ th}}$				23	28	49	
80.694	2787	3.5	M_2				906	493	814	
			c				3	5.4	3.2	
			$n_{2 \text{ Eck}}$				20	25	43	
			$n_{2 \text{ th}}$				20	25	43	
87.267	2657	3.22	M_2				983	537	884	430
			c				2.7	4.8	2.8	5.3
			$n_{2 \text{ Eck}}$				19	23	40	47
			$n_{2 \text{ th}}$				19	23	40	41
99.167	2810	3.2	M_2				1120	612	1006	491
			c				2.5	4.4	2.6	5
			$n_{2 \text{ Eck}}$				17	20	35	41
			$n_{2 \text{ th}}$				16	20	35	36
112.933	2695	2.93	M_2				1280	702	1151	563
			c				2.1	3.7	2.2	4.2
			$n_{2 \text{ Eck}}$				15	18	31	36
			$n_{2 \text{ th}}$				14	18	31	32
129.074	2810	1.94	M_2		757	472	1466	806	1318	647
			c		3.5	5.2	1.9	3.4	2	3.8
			$n_{2 \text{ Eck}}$		26	31	13	16	27	32
			$n_{2 \text{ th}}$		26	31	13	15	27	28

$M \dots$ [Nm]
 $n \dots$ [min^{-1}]
 $J \dots$ [kgcm^2]

$P \dots$ [kW]
 $I \dots$ [A]
 i [-]
 c [-]

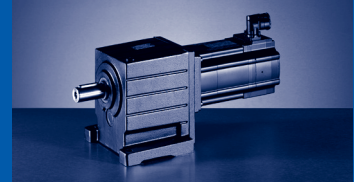

$M_{2GN} \leq 2848 \text{ Nm}$

17NC17	17NC23	17NC35	17NC41	19SC17	19SC23	19SC35	19SC42	GST11-3A			
...F10	...S00	...F10	...S00	...F10	...S00	...F10	...S00	M_1	J_G	M_{2GN}	i
21.5	10.8	19	9.5	36.3	16.3	36	12	n_1			
1680	2300	3480	4110	1700	2340	3510	4150	I_{M400}			
8.5	5.5	15.8	10.2	13.9	8.2	28.7	14	P_N			
3.8	2.6	6.9	4.1	6.4	4	13.2	5.2	J_M			
36.04	36.04	36.04	36.04	72.12	72.12	72.04	72.12	M_2			
								c			
								n_{2Eck}	6.36	1641	40.816
								n_{2th}			
								M_2			
								c			
								n_{2Eck}	6.36	2444	40.816
								n_{2th}			
821	399	726	353	1404	616	1396	451	M_2			
3	6	3	5.6	1.8	3.9	1.6	4.4	c			
41	56	85	101	42	57	86	102	n_{2Eck}	6.36	2550	40.816
41	56	76	76	42	57	60	60	n_{2th}			
888	434	783	381	1517	667	1506	487	M_2			
2.7	5.3	2.9	5.4	1.6	3.5	1.5	4.3	c			
38	52	79	93	39	53	80	94	n_{2Eck}	5.66	2410	44
38	52	71	71	39	53	56	56	n_{2th}			
1010	493	890	433	1724	759	1711	554	M_2			
2.7	5.3	2.9	5.4	1.6	3.5	1.5	4.3	c			
34	46	70	82	34	47	70	83	n_{2Eck}	5.6	2725	50
34	46	62	62	34	47	49	49	n_{2th}			
1177	578	1038	508	2005	885	1990	648	M_2			
2.2	4.3	2.3	4.4	1.3	2.9	1.2	3.5	c			
29	40	60	71	29	40	61	72	n_{2Eck}	4.77	2577	57.968
29	40	54	54	29	40	42	42	n_{2th}			
1243	610	1097	536	2119	936	2102	684	M_2			
2.2	4.3	2.3	4.4	1.3	2.9	1.2	3.5	c			
27	38	57	67	28	38	57	68	n_{2Eck}	4.08	2725	61.25
27	38	51	51	28	38	40	40	n_{2th}			
1447	713	1277	627	2462	1090	2442	798	M_2			
1.8	3.6	2	3.7	1.1	2.4	1	2.9	c			
24	32	49	58	24	33	49	58	n_{2Eck}	3.52	2637	71.011
24	32	44	44	24	33	34	34	n_{2th}			
1646	812	1453	714		1241		909	M_2			
1.7	3.4	1.8	3.4		2.2		2.7	c			
21	29	43	51		29		51	n_{2Eck}	3.5	2787	80.694
21	29	39	39		29		30	n_{2th}			
1784	882	1575	776		1346		986	M_2			
1.5	3	1.6	3		2		2.4	c			
19	26	40	47		27		48	n_{2Eck}	3.22	2657	87.267
19	26	36	36		27		28	n_{2th}			
2029	1005	1792	883		1532		1123	M_2			
1.4	2.8	1.5	2.8		1.8		2.2	c			
17	23	35	42		24		42	n_{2Eck}	3.2	2810	99.167
17	23	31	31		24		25	n_{2th}			
2317	1150	2045	1011		1749		1283	M_2			
1.2	2.3	1.3	2.4		1.5		1.9	c			
15	20	31	36		21		37	n_{2Eck}	2.93	2695	112.933
15	20	28	28		21		22	n_{2th}			
2650	1317	2340	1158					M_2			
1.1	2.1	1.1	2.2					c			
13	18	27	32					n_{2Eck}	1.94	2810	129.074
13	18	24	24					n_{2th}			

M ... [Nm]
n ... [min⁻¹]
J ... [kgcm²]

P ... [kW]
I ... [A]
i [-]
c [-]

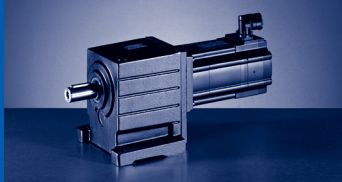

GST [Nm]

GST□□-□A (MCA)

$M_{2GN} \leq 2848 \text{ Nm}$

GST11-3A				10IC40	13IC34	13IC41	14LC16	14LC20	14LC35	14LC41
				...500	...F10	...500	...F10	...500	...F10	...500
i	M_{2GN}	J_G	M_1	2	6.3	4	12	6.7	10.8	5.4
			n_1	3950	3410	4050	1635	2000	3455	4100
			I_{M400}	2.4	6	4.4	4.8	3.3	9.1	5.8
			P_N	0.8	2.2	1.7	2.1	1.4	3.9	2.3
			J_M	2.44	8.34	8.34	19.32	19.24	19.24	19.24
146.993	2695	1.77	M_2		867	542	1675	923	1506	741
			c		2.9	4.3	1.6	2.9	1.7	3.2
			$n_{2 \text{ Eck}}$		23	28	11	14	24	28
			$n_{2 \text{ th}}$		23	28	11	14	24	24
158.194	2810	1.4	M_2		934	584	1804	994	1622	798
			c		2.8	4.2	1.6	2.8	1.6	3.1
			$n_{2 \text{ Eck}}$		22	26	10	13	22	26
			$n_{2 \text{ th}}$		22	26	10	13	22	23
180.156	2695	1.29	M_2		1069	670	2059	1137	1852	914
			c		2.4	3.5	1.3	2.3	1.4	2.6
			$n_{2 \text{ Eck}}$		19	23	9	11	19	23
			$n_{2 \text{ th}}$		19	22	9	11	19	20
207.778	2810	0.88	M_2		1236	776	2378	1315	2139	1057
			c		2.2	3.2	1.2	2.1	1.3	2.4
			$n_{2 \text{ Eck}}$		16	20	8	10	17	20
			$n_{2 \text{ th}}$		16	19	8	10	17	17
236.622	2695	0.82	M_2	431	1413	888		1503	2441	1208
			c	5.4	1.8	2.7		1.8	1.1	2
			$n_{2 \text{ Eck}}$	17	14	17		9	15	17
			$n_{2 \text{ th}}$	17	14	17		8	15	15
252.167	2810	0.63	M_2	460	1506	947		1602	2602	1288
			c	5.3	1.8	2.6		1.7	1	2
			$n_{2 \text{ Eck}}$	16	14	16		8	14	16
			$n_{2 \text{ th}}$	16	14	16		8	14	14
268.889	2848	0.82	M_2	492	1607	1012		1710		1375
			c	5.1	1.7	2.5		1.7		1.9
			$n_{2 \text{ Eck}}$	15	13	15		7		15
			$n_{2 \text{ th}}$	15	13	15		7		13
326.333	2848	0.59	M_2	603	1957	1234		2082		1675
			c	4.2	1.4	2.1		1.4		1.5
			$n_{2 \text{ Eck}}$	12	11	12		6		13
			$n_{2 \text{ th}}$	12	10	12		6		11
363	2695	0.76	M_2	675	2181	1377				
			c	3.5	1.2	1.8				
			$n_{2 \text{ Eck}}$	11	9	11				
			$n_{2 \text{ th}}$	11	9	11				
412.5	2848	0.55	M_2	769	2481	1566				
			c	3.3	1.1	1.6				
			$n_{2 \text{ Eck}}$	10	8	10				
			$n_{2 \text{ th}}$	10	8	10				

M ... [Nm]
 n ... [min⁻¹]
 J ... [kgcm²]

P ... [kW]
 I ... [A]
 i [-]
 c [-]



$M_{2GN} \leq 2848 \text{ Nm}$

17NC17	17NC23	17NC35	17NC41	19SC17	19SC23	19SC35	19SC42	GST11-3A			
...F10	...S00	...F10	...S00	...F10	...S00	...F10	...S00	M_1	J_G	M_{2GN}	i
21.5	10.8	19	9.5	36.3	16.3	36	12	n_1			
1680	2300	3480	4110	1700	2340	3510	4150	I_{M400}			
8.5	5.5	15.8	10.2	13.9	8.2	28.7	14	P_N			
3.8	2.6	6.9	4.1	6.4	4	13.2	5.2	J_M			
36.04	36.04	36.04	36.04	72.12	72.12	72.04	72.12	M_2			
	1505		1323					c			
	1.8		1.8					$n_{2 \text{ Eck}}$	1.77	2695	146.993
	16		28					$n_{2 \text{ th}}$			
	16		21					M_2			
	1620		1425					c			
	1.7		1.8					$n_{2 \text{ Eck}}$	1.4	2810	158.194
	15		26					$n_{2 \text{ th}}$			
	15		20					M_2			
	1851		1627					c			
	1.5		1.5					$n_{2 \text{ Eck}}$	1.29	2695	180.156
	13		23					$n_{2 \text{ th}}$			
	13		17					M_2			
								c			
								$n_{2 \text{ Eck}}$	0.88	2810	207.778
								$n_{2 \text{ th}}$			
								M_2			
								c			
								$n_{2 \text{ Eck}}$	0.82	2695	236.622
								$n_{2 \text{ th}}$			
								M_2			
								c			
								$n_{2 \text{ Eck}}$	0.63	2810	252.167
								$n_{2 \text{ th}}$			
								M_2			
								c			
								$n_{2 \text{ Eck}}$	0.82	2848	268.889
								$n_{2 \text{ th}}$			
								M_2			
								c			
								$n_{2 \text{ Eck}}$	0.59	2848	326.333
								$n_{2 \text{ th}}$			
								M_2			
								c			
								$n_{2 \text{ Eck}}$	0.76	2695	363
								$n_{2 \text{ th}}$			
								M_2			
								c			
								$n_{2 \text{ Eck}}$	0.55	2848	412.5
								$n_{2 \text{ th}}$			

M ... [Nm]
n ... [min⁻¹]
J ... [kgcm²]

P ... [kW]
I ... [A]
i [-]
c [-]

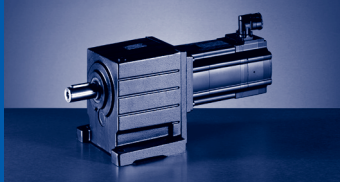

GST [Nm]

GST□□-□A (MCA)

$M_{2GN} \leq 5786 \text{ Nm}$

GST14-2A				195C17	195C23	195C35	21XC17	21XC25	21XC35	
				...F10	...S00	...F10	...F10	...S00	...F10	
i	M_{2GN}	J_G	M_1	36.3	16.3	36	61.4	24.6	55	
			n_1	1700	2340	3510	1710	2490	3520	
			I_{M400}	13.9	8.2	28.7	22.5	13.5	42.5	
			P_N	6.4	4	13.2	11	6.4	20.3	
			J_M	72.12	72.12	72.04	180.04	180.04	180.04	
8.027	3168	100	M_2						408	
			c						5.6	
			n_2 Eck							439
			n_2 th							251
8.8	3737	139	M_2						445	
			c						6	
			n_2 Eck							400
			n_2 th							195
9.841	3333	75.1	M_2				559		505	
			c				5.4		4.8	
			n_2 Eck				174		358	
			n_2 th				174		205	
11	3940	119	M_2				623		562	
			c				5.8		5.1	
			n_2 Eck				156		320	
			n_2 th				155		154	
12.362	4176	89	M_2				703		634	
			c				5.4		4.8	
			n_2 Eck				138		285	
			n_2 th				138		158	
14.048	4270	86.6	M_2				803		724	
			c				4.9		4.3	
			n_2 Eck				122		251	
			n_2 th				122		136	
15.156	4466	67.6	M_2				866		778	
			c				5		4.7	
			n_2 Eck				113		232	
			n_2 th				113		133	
17.222	4565	66	M_2				989		888	
			c				4.5		4.3	
			n_2 Eck				99		204	
			n_2 th				99		117	
20.044	3958	45.8	M_2	672		672				
			c	5.6		4.8				
			n_2 Eck	85		175				
			n_2 th	85		122				
20.044	4902	45.8	M_2				1156		1037	
			c				4.1		3.9	
			n_2 Eck				85		176	
			n_2 th				85		100	
22.778	4498	44.9	M_2	764		764				
			c	5.6		4.8				
			n_2 Eck	75		154				
			n_2 th	75		108				
22.778	5010	44.9	M_2				1319		1184	
			c				3.7		3.5	
			n_2 Eck				75		155	
			n_2 th				75		88	
24.567	4286	33.2	M_2	830		829				
			c	5		4.3				
			n_2 Eck	69		143				
			n_2 th	69		100				

$M \dots$ [Nm]
 $n \dots$ [min^{-1}]
 $J \dots$ [kgcm^2]

$P \dots$ [kW]
 $I \dots$ [A]
 i [-]
 c [-]

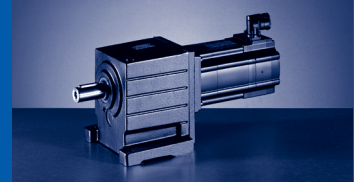

$M_{2GN} \leq 5786 \text{ Nm}$

GST14-2A				195C17	195C23	195C35	21XC17	21XC25	21XC35
				...F10	...S00	...F10	...F10	...S00	...F10
i	M_{2GN}	J_G	M_1						
			n_1	1700	2340	3510	1710	2490	3520
			I_{M400}	13.9	8.2	28.7	22.5	13.5	42.5
			P_N	6.4	4	13.2	11	6.4	20.3
			J_M	72.12	72.12	72.04	180.04	180.04	180.04
24.567	5236	33.2	M_2				1425		1278
			c				3.6		3.4
			$n_{2 \text{ Eck}}$				70		143
			$n_{2 \text{ th}}$				70		82
27.917	4871	32.6	M_2	943		942			
			c	5		4.3			
			$n_{2 \text{ Eck}}$	61		126			
			$n_{2 \text{ th}}$	61		88			
27.917	5355	32.6	M_2				1625		1458
			c				3.2		3.1
			$n_{2 \text{ Eck}}$				61		126
			$n_{2 \text{ th}}$				61		72
32.267	4423	21.5	M_2	1103		1100			
			c	3.9		3.4			
			$n_{2 \text{ Eck}}$	53		109			
			$n_{2 \text{ th}}$	53		76			
32.267	5436	21.5	M_2				1886		1692
			c				2.8		2.7
			$n_{2 \text{ Eck}}$				53		109
			$n_{2 \text{ th}}$				53		62
36.667	5026	21.2	M_2	1253		1250			
			c	3.9		3.4			
			$n_{2 \text{ Eck}}$	46		96			
			$n_{2 \text{ th}}$	46		67			
36.667	5768	21.2	M_2				2147		1926
			c				2.6		2.5
			$n_{2 \text{ Eck}}$				47		96
			$n_{2 \text{ th}}$				47		55
39.16	4493	15.7	M_2	1347		1342			
			c	3.3		2.8			
			$n_{2 \text{ Eck}}$	43		90			
			$n_{2 \text{ th}}$	43		63			
39.16	5452	15.7	M_2				2301	890	2063
			c				2.3	5.6	2.2
			$n_{2 \text{ Eck}}$				44	64	90
			$n_{2 \text{ th}}$				44	51	51
44.5	5106	15.5	M_2	1531		1520			
			c	3.3		3.1			
			$n_{2 \text{ Eck}}$	38		79			
			$n_{2 \text{ th}}$	38		55			
44.5	5786	15.5	M_2				2619	1013	2343
			c				2.2	5.5	2.3
			$n_{2 \text{ Eck}}$				38	56	79
			$n_{2 \text{ th}}$				38	45	45
49.5	4348	10.6	M_2	1717	746	1704			
			c	2.5	5.6	2.4			
			$n_{2 \text{ Eck}}$	34	47	71			
			$n_{2 \text{ th}}$	34	47	49			
56.25	4940	10.5	M_2	1951	848	1937			
			c	2.5	5.6	2.4			
			$n_{2 \text{ Eck}}$	30	42	62			
			$n_{2 \text{ th}}$	30	42	44			

$M \dots$ [Nm]
 $n \dots$ [min^{-1}]
 $J \dots$ [kgcm^2]

$P \dots$ [kW]
 $I \dots$ [A]
 i [-]
 c [-]

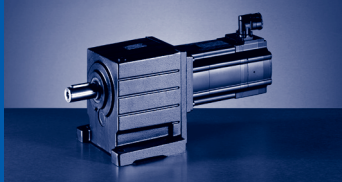

GST [Nm]

GST□□-□A (MCA)

$M_{2GN} \leq 5920 \text{ Nm}$

GST14-3A				14LC16	14LC20	14LC35	14LC41	17NC17	17NC23	17NC35	17NC41	
				...F10	...S00	...F10	...S00	...F10	...S00	...F10	...S00	
i	M_{2GN}	J_G	M_1	12	6.7	10.8	5.4	21.5	10.8	19	9.5	
			n_1	1635	2000	3455	4100	1680	2300	3480	4110	
			I_{M400}	4.8	3.3	9.1	5.8	8.5	5.5	15.8	10.2	
			P_N	2.1	1.4	3.9	2.3	3.8	2.6	6.9	4.1	
			J_M	19.32	19.24	19.24	19.24	36.04	36.04	36.04	36.04	
40.185	4099	24.4	M_2					791		700		
			c					5		4.8		
			n_2 Eck						42		87	
			n_2 th						42		77	
			M_2									
40.185	4476	24.4	c									
			n_2 Eck									
			n_2 th									
			M_2									
			c					844		743		
42.58	3804	18.3	n_2 Eck					4.4		4.7		
			n_2 th					40		82		
			c					39		73		
			M_2									
			c									
42.58	4262	18.3	n_2 Eck									
			n_2 th									
			M_2									
			c					959		845		
			n_2 Eck					4.4		4.7		
48.386	4323	18.1	n_2 th					35		72		
			c					35		64		
			M_2									
			c									
			n_2 Eck									
48.386	4843	18.1	n_2 th									
			c									
			M_2									
			c					1053		928		
			n_2 Eck					4.4		4.7		
53.148	4779	20.5	n_2 th					32		66		
			c					32		59		
			M_2									
			c					1184		1043		
			n_2 Eck					3.7		4		
59.321	4546	13.2	n_2 th					28		59		
			c					28		52		
			M_2									
			c									
			n_2 Eck									
59.321	5267	13.2	n_2 th									
			c									
			M_2									
			c					1382		1218		
			n_2 Eck					3.5		3.7		
69.042	4917	11.5	n_2 th					24		50		
			c					24		45		
			M_2									
			c					1570		1384		
			n_2 Eck					3.5		3.7		
78.457	5587	11.4	n_2 th					21		44		
			c					21		40		
			M_2									
			c									
			n_2 Eck									
93.541	4793	6.57	n_2 th	1034		928						
			c	4.5		4.7						
			n_2 Eck	18		37						
			n_2 th	17		37						
			M_2									
93.541	5524	6.57	c					1884	918	1661	806	
			n_2 Eck					2.9	5.7	3.1	5.9	
			n_2 th					18	25	37	44	
			c					18	25	33	33	
			n_2 th									

$M \dots$ [Nm]
 $n \dots$ [min^{-1}]
 $J \dots$ [kgcm^2]

$P \dots$ [kW]
 $I \dots$ [A]
 i [-]
 c [-]

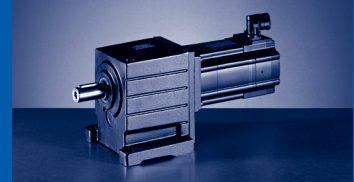

$M_{2GN} \leq 5920 \text{ Nm}$

195C17	195C23	195C35	195C42	21XC17	21XC25	21XC35	21XC42	GST14-3A			
...F10	...S00	...F10	...S00	...F10	...S00	...F10	...S00	M_1	J_G	M_{2GN}	i
36.3	16.3	36	12	61.4	24.6	55	17	n_1			
1700	2340	3510	4150	1710	2490	3520	4160	I_{M400}			
13.9	8.2	28.7	14	22.5	13.5	42.5	19.8	P_N			
6.4	4	13.2	5.2	11	6.4	20.3	7.4	J_M			
72.12	72.12	72.04	72.12	180.04	180.04	180.04	180.04	M_2 c $n_{2\text{ Eck}}$ $n_{2\text{ th}}$	24.4	4099	40.185
1362		1357		2336	910	2094	622	M_2 c $n_{2\text{ Eck}}$ $n_{2\text{ th}}$	24.4	4476	40.185
3.2		2.8		1.9	4.6	1.8	5.5				
42		87		43	62	88	104				
42		61		43	50	50	50				
								M_2 c $n_{2\text{ Eck}}$ $n_{2\text{ th}}$	18.3	3804	42.58
1448		1438		2480	967	2219	659	M_2 c $n_{2\text{ Eck}}$ $n_{2\text{ th}}$	18.3	4262	42.58
2.9		2.8		1.7	4.3	1.8	5.5				
40		82		40	59	83	98				
40		58		40	47	47	47				
								M_2 c $n_{2\text{ Eck}}$ $n_{2\text{ th}}$	18.1	4323	48.386
1645		1634		2818	1099	2522	749	M_2 c $n_{2\text{ Eck}}$ $n_{2\text{ th}}$	18.1	4843	48.386
2.9		2.8		1.7	4.3	1.8	5.5				
35		73		35	52	73	86				
35		51		35	42	42	42				
1813	787	1800		3101	1213	2775	828	M_2 c $n_{2\text{ Eck}}$ $n_{2\text{ th}}$	20.5	4779	53.148
2.6	5.8	2.5		1.5	3.8	1.6	5				
32	44	66		32	47	66	78				
32	44	46		32	38	38	38				
								M_2 c $n_{2\text{ Eck}}$ $n_{2\text{ th}}$	13.2	4546	59.321
2024	879	2010		3462	1354	3098	924	M_2 c $n_{2\text{ Eck}}$ $n_{2\text{ th}}$	13.2	5267	59.321
2.6	5.7	2.5		1.5	3.8	1.6	4.9				
29	40	59		29	42	59	70				
29	39	41		29	34	34	34				
2369	1035	2351	754	4042	1589	3618	1087	M_2 c $n_{2\text{ Eck}}$ $n_{2\text{ th}}$	11.5	4917	69.042
2.1	4.6	2	5.6	1.2	3	1.3	3.9				
25	34	51	60	25	36	51	60				
25	34	35	35	25	29	29	29				
2692	1176	2672	857	4593	1805	4112	1236	M_2 c $n_{2\text{ Eck}}$ $n_{2\text{ th}}$	11.4	5587	78.457
2.1	4.6	2	5.6	1.2	3	1.3	3.9				
22	30	45	53	22	32	45	53				
22	30	31	31	22	26	26	26				
								M_2 c $n_{2\text{ Eck}}$ $n_{2\text{ th}}$	6.57	4793	93.541
3221	1415	3197	1032					M_2 c $n_{2\text{ Eck}}$ $n_{2\text{ th}}$	6.57	5524	93.541
1.7	3.8	1.6	4.6								
18	25	38	44								
18	25	26	26								

M ... [Nm]
n ... [min⁻¹]
J ... [kgcm²]

P ... [kW]
I ... [A]
i [-]
c [-]

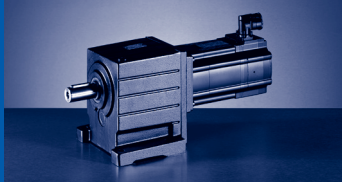

GST [Nm]

GST□□-□A (MCA)

$M_{2GN} \leq 5920 \text{ Nm}$

GST14-3A				14LC16	14LC20	14LC35	14LC41	17NC17	17NC23	17NC35	17NC41
				...F10	...S00	...F10	...S00	...F10	...S00	...F10	...S00
i	M_{2GN}	J_G	M_1	12	6.7	10.8	5.4	21.5	10.8	19	9.5
			n_1	1635	2000	3455	4100	1680	2300	3480	4110
			I_{M400}	4.8	3.3	9.1	5.8	8.5	5.5	15.8	10.2
			P_N	2.1	1.4	3.9	2.3	3.8	2.6	6.9	4.1
			J_M	19.32	19.24	19.24	19.24	36.04	36.04	36.04	36.04
96.157	5882	10.4	M_2					1935	941	1706	
			c				3	5.9	3.2		
			$n_{2 \text{ Eck}}$				18	24	36		
			$n_{2 \text{ th}}$				17	24	32		
106.296	5447	6.52	M_2	1175		1054					
			c	4.5		4.7					
			$n_{2 \text{ Eck}}$	15		33					
			$n_{2 \text{ th}}$	15		33					
106.296	5920	6.52	M_2					2145	1047	1891	919
			c					2.7	5.4	2.9	5.5
			$n_{2 \text{ Eck}}$					16	22	33	39
			$n_{2 \text{ th}}$					16	22	29	29
130.278	5920	6	M_2	1448		1300		2643	1297	2331	1139
			c	4		4.2		2.2	4.4	2.4	4.5
			$n_{2 \text{ Eck}}$	13		27		13	18	27	32
			$n_{2 \text{ th}}$	13		27		13	18	24	24
139.211	5736	4.42	M_2	1553		1395		2830	1392	2497	1223
			c	3.6		3.8		2	4	2.2	4.1
			$n_{2 \text{ Eck}}$	12		25		12	17	25	30
			$n_{2 \text{ th}}$	12		25		12	17	22	22
158.194	5920	4.4	M_2	1771	962	1591		3222	1588	2844	1395
			c	3.3	5.8	3.5		1.8	3.6	2	3.7
			$n_{2 \text{ Eck}}$	10	13	22		11	15	22	26
			$n_{2 \text{ th}}$	10	13	22		11	15	20	20
171.111	5920	5.49	M_2	1921	1045	1725		3491	1723	3081	1514
			c	3	5.4	3.2		1.7	3.4	1.8	3.4
			$n_{2 \text{ Eck}}$	10	12	20		10	13	20	24
			$n_{2 \text{ th}}$	10	12	20		10	13	18	18
204.722	5920	2.86	M_2	2310	1263	2076	1012	4188	2073	3697	1822
			c	2.5	4.5	2.7	5.1	1.4	2.8	1.5	2.9
			$n_{2 \text{ Eck}}$	8	10	17	20	8	11	17	20
			$n_{2 \text{ th}}$	8	10	17	18	8	11	15	15
236.622	5779	2.65	M_2	2682	1470	2410	1179	4852	2407	4284	2116
			c	2.1	3.8	2.3	4.3	1.2	2.4	1.3	2.4
			$n_{2 \text{ Eck}}$	7	9	15	17	7	10	15	17
			$n_{2 \text{ th}}$	7	8	15	15	7	10	13	13
248.458	5920	2.06	M_2	2817	1546	2532	1240	5097	2529	4500	2224
			c	2.1	3.7	2.2	4.2	1.2	2.3	1.3	2.4
			$n_{2 \text{ Eck}}$	7	8	14	17	7	9	14	17
			$n_{2 \text{ th}}$	7	8	14	14	7	9	13	13
268.889	5920	2.65	M_2	3054	1678	2745	1346	5521	2742	4875	2411
			c	1.9	3.4	2	3.8	1.1	2.1	1.2	2.2
			$n_{2 \text{ Eck}}$	6	7	13	15	6	9	13	15
			$n_{2 \text{ th}}$	6	7	13	13	6	9	12	12
326.333	5920	1.92	M_2	3720	2049	3344	1646		3341		2938
			c	1.6	2.8	1.7	3.2		1.8		1.8
			$n_{2 \text{ Eck}}$	5	6	11	13		7		13
			$n_{2 \text{ th}}$	5	6	11	11		7		10
363	5779	2.45	M_2	4146	2288	3728	1838				
			c	1.4	2.5	1.5	2.8				
			$n_{2 \text{ Eck}}$	5	6	10	11				
			$n_{2 \text{ th}}$	5	6	10	10				

$M \dots$ [Nm]
 $n \dots$ [min^{-1}]
 $J \dots$ [kgcm^2]

$P \dots$ [kW]
 $I \dots$ [A]
 i [-]
 c [-]

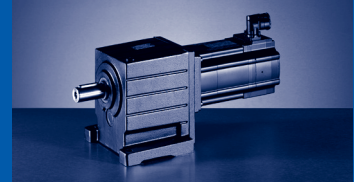

$M_{2GN} \leq 5920 \text{ Nm}$

195C17	195C23	195C35	195C42	21XC17	21XC25	21XC35	21XC42	GST14-3A			
...F10	...S00	...F10	...S00	...F10	...S00	...F10	...S00	M_1	J_G	M_{2GN}	i
36.3	16.3	36	12	61.4	24.6	55	17	n_1			
1700	2340	3510	4150	1710	2490	3520	4160	I_{M400}			
13.9	8.2	28.7	14	22.5	13.5	42.5	19.8	P_N			
6.4	4	13.2	5.2	11	6.4	20.3	7.4	J_M			
72.12	72.12	72.04	72.12	180.04	180.04	180.04	180.04	M_2			
3309	1452	3284	1059	5640	2223	5049	1523	c	10.4	5882	96.157
1.8	3.9	1.7	4.8	1	2.6	1.1	3.4	$n_{2 \text{ Eck}}$			
18	24	37	43	18	26	37	43	$n_{2 \text{ th}}$			
18	24	25	25	18	21	21	21	M_2			
								c	6.52	5447	106.296
								$n_{2 \text{ Eck}}$			
								$n_{2 \text{ th}}$			
3664	1611	3637	1176					M_2			
1.6	3.6	1.5	4.4					c	6.52	5920	106.296
16	22	33	39					$n_{2 \text{ Eck}}$			
16	22	23	23					$n_{2 \text{ th}}$			
4505	1989	4470	1454					M_2			
1.3	2.9	1.3	3.6					c	6	5920	130.278
13	18	27	32					$n_{2 \text{ Eck}}$			
13	18	19	19					$n_{2 \text{ th}}$			
4820	2131	4783	1559					M_2			
1.2	2.7	1.1	3.2					c	4.42	5736	139.211
12	17	25	30					$n_{2 \text{ Eck}}$			
12	17	18	18					$n_{2 \text{ th}}$			
5483	2428	5441	1778					M_2			
1.1	2.4	1	2.9					c	4.4	5920	158.194
11	15	22	26					$n_{2 \text{ Eck}}$			
11	15	15	15					$n_{2 \text{ th}}$			
	2631		1927					M_2			
	2.2		2.7					c	5.49	5920	171.111
	14		24					$n_{2 \text{ Eck}}$			
	14		14					$n_{2 \text{ th}}$			
								M_2			
								c	2.86	5920	204.722
								$n_{2 \text{ Eck}}$			
								$n_{2 \text{ th}}$			
								M_2			
								c	2.65	5779	236.622
								$n_{2 \text{ Eck}}$			
								$n_{2 \text{ th}}$			
								M_2			
								c	2.06	5920	248.458
								$n_{2 \text{ Eck}}$			
								$n_{2 \text{ th}}$			
								M_2			
								c	2.65	5920	268.889
								$n_{2 \text{ Eck}}$			
								$n_{2 \text{ th}}$			
								M_2			
								c	1.92	5920	326.333
								$n_{2 \text{ Eck}}$			
								$n_{2 \text{ th}}$			
								M_2			
								c	2.45	5779	363
								$n_{2 \text{ Eck}}$			
								$n_{2 \text{ th}}$			

M ... [Nm]
n ... [min⁻¹]
J ... [kgcm²]

P ... [kW]
I ... [A]
i [-]
c [-]

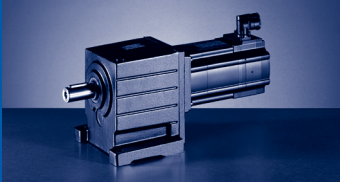

GST [Nm]

GST□□-□A (MCA)

$M_{2GN} \leq 5920 \text{ Nm}$

GST14-3A				14LC16	14LC20	14LC35	14LC41	17NC17	17NC23	17NC35	17NC41
				...F10	...S00	...F10	...S00	...F10	...S00	...F10	...S00
i	M_{2GN}	J_G	M_1	12	6.7	10.8	5.4	21.5	10.8	19	9.5
			n_1	1635	2000	3455	4100	1680	2300	3480	4110
			I_{M400}	4.8	3.3	9.1	5.8	8.5	5.5	15.8	10.2
			P_N	2.1	1.4	3.9	2.3	3.8	2.6	6.9	4.1
			J_M	19.32	19.24	19.24	19.24	36.04	36.04	36.04	36.04
412.5	5920	1.78	M_2	4718	2607	4243	2095				
			c	1.3	2.2	1.3	2.5				
			$n_{2 \text{ Eck}}$	4	5	8	10				
			$n_{2 \text{ th}}$	4	5	8	9				

M ... [Nm]
 n ... [min⁻¹]
 J ... [kgcm²]

P ... [kW]
 I ... [A]
 i [-]
 c [-]



$M_{2GN} \leq 5920 \text{ Nm}$

195C17	195C23	195C35	195C42	21XC17	21XC25	21XC35	21XC42	GST14-3A			
...F10	...S00	...F10	...S00	...F10	...S00	...F10	...S00	M_1	J_G	M_{2GN}	i
36.3	16.3	36	12	61.4	24.6	55	17	n_1			
1700	2340	3510	4150	1710	2490	3520	4160	I_{M400}			
13.9	8.2	28.7	14	22.5	13.5	42.5	19.8	P_N			
6.4	4	13.2	5.2	11	6.4	20.3	7.4	J_M			
72.12	72.12	72.04	72.12	180.04	180.04	180.04	180.04	M_2			
								c			
								$n_{2 \text{ Eck}}$	1.78	5920	412.5
								$n_{2 \text{ th}}$			

M ... [Nm]
n ... [min^{-1}]
J ... [kgcm^2]

P ... [kW]
I ... [A]
i [-]
c [-]

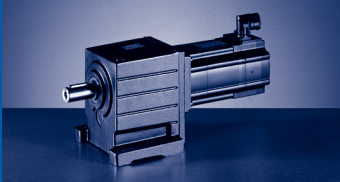

GST [mm]

GST□□-1S (MCS)

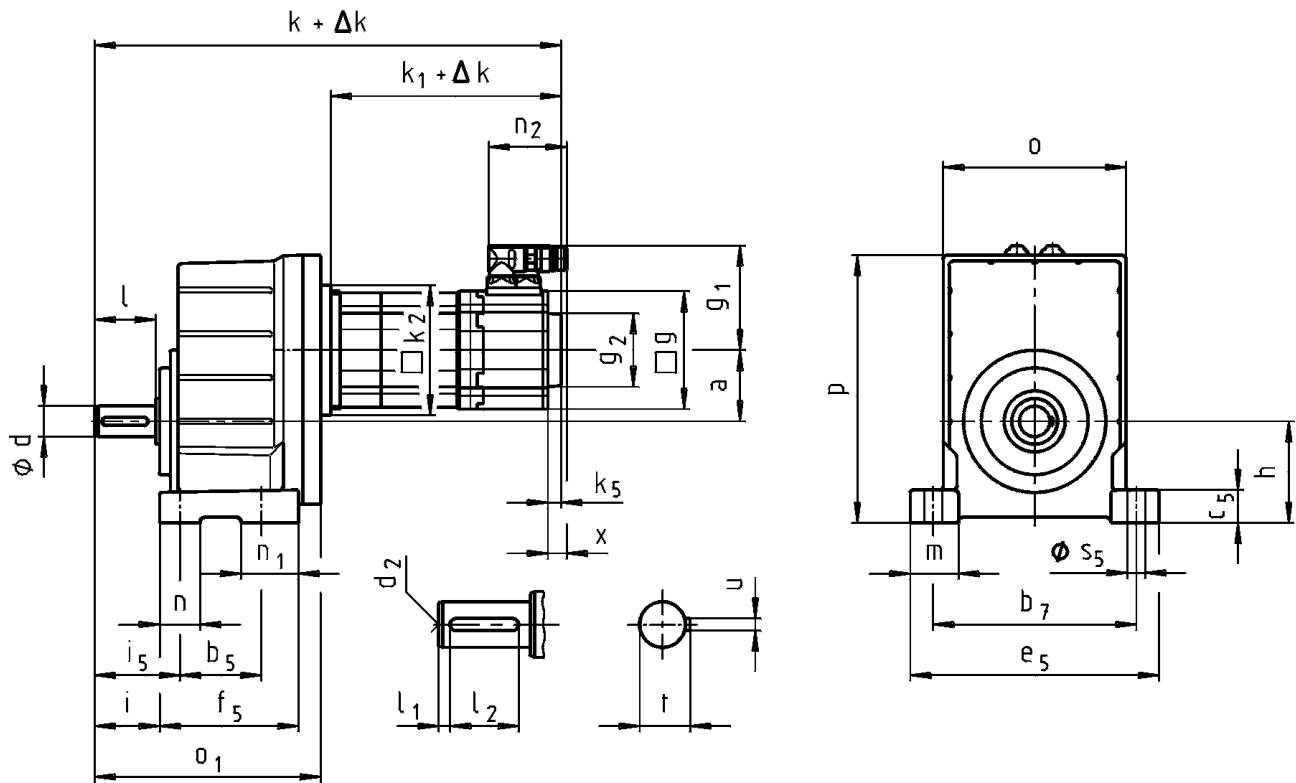

GST□□-1S VBR ... RSO

		06C C41	06F C41	06I C41	09D C41	09F C38	09H C41	09L C41	12D C20	12D C41	12H C15	12H C30	12H C35	12L C20	12L C41
GST04...	k	279	309	339	331	351	371	411							
GST05...	k	300	330	360	352	372	392	432	369		409			449	
GST06...	k	323	353	383	375	395	415	455	392		432			472	
GST07...	k				404	424	444	484	421		461			501	
GST09...	k								464		504			544	
...RSO B0 ¹⁾	Δk	0													
...RSO P□ ¹⁾	Δk	19				20									
...RSO	k_1	132	162	192	183	203	223	263	188		228			268	
	k_2	66			91								118	145 ²⁾	
	g	62			89								116		
	k_5	0			13								14		
	g_2	□ 62			Ø 67								Ø 72		
	g_1	76			90								105		
	n_2	64							78						
	x	21								18					

¹⁾ → 801 - SRS / SRM / ECN / EQN / EQJ / C20

²⁾ GST05: 12DC20 ... 12LC41

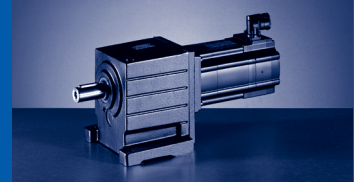

GST□□-1S VBR ... RSO

		14D C15	14D C36	14H C15	14H C32	14L C15	14L C32	14P C14	14P C32	19F C14	19F C30	19J C14	19J C30	19P C14	19P C30				
GST06...	k	408		448		488		528											
GST07...	k	437		477		517		557		476		516		576					
GST09...	k	480		520		560		600		519		559		619					
...RSO B0 ¹⁾	Δ k	0																	
...RSO P□ ¹⁾	Δ k	28						34			44								
	k ₁	201		241		281		321		220		260		320					
	k ₂	145						195											
	g	143						192											
...RSO	k ₅	24						15											
	g ₂	Ø 78																	
	g ₁	116				147		116		147		141		172		141		172	
	n ₂	78				94		78		94		78		94		78		94	
	x	16				38		16		38		16		36		16		36	

¹⁾ → 801 - SRS / SRM / ECN / EQN / EQI / C20

GST□□-1S VBR

	o	o ₁	p	h	a
GST04...	100	134	138	50	36
GST05...	115	165	168	63	45
GST06...	145	191	211	80	56
GST07...	180	223	264	100	70
GST09...	222	271	329	125	89

	d	l	l ₁	l ₂	d ₂	u	t	b ₅	b ₇	c ₅	e ₅	f ₅	i	i ₅	m	n	n ₁	s ₅
GST04...	16	32	6	20	M5	5	18	55	105	17	128	80	35	45	24	20	25	9
GST05...	20	40		28	M6	6	22.5	70	125	22	154	99	43	56	32	26	29	11
GST06...	25	50	4	40	M10	8	28	72	160	27	194	115	53	68	37	30	43	13.5
GST07...	30	60	7.5	45				80	200	35	245	137	64	84	48	40	57	
GST09...	40	80	8.5	63	M16	12	43	105	245	43	296	161	84	107	51	45	56	18

d ≤ 50 mm: k6; d > 50 mm: m6

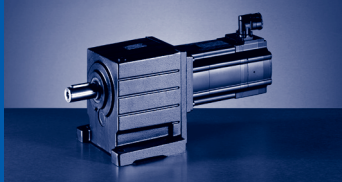

GST [mm]

GST□□-1S (MCS)

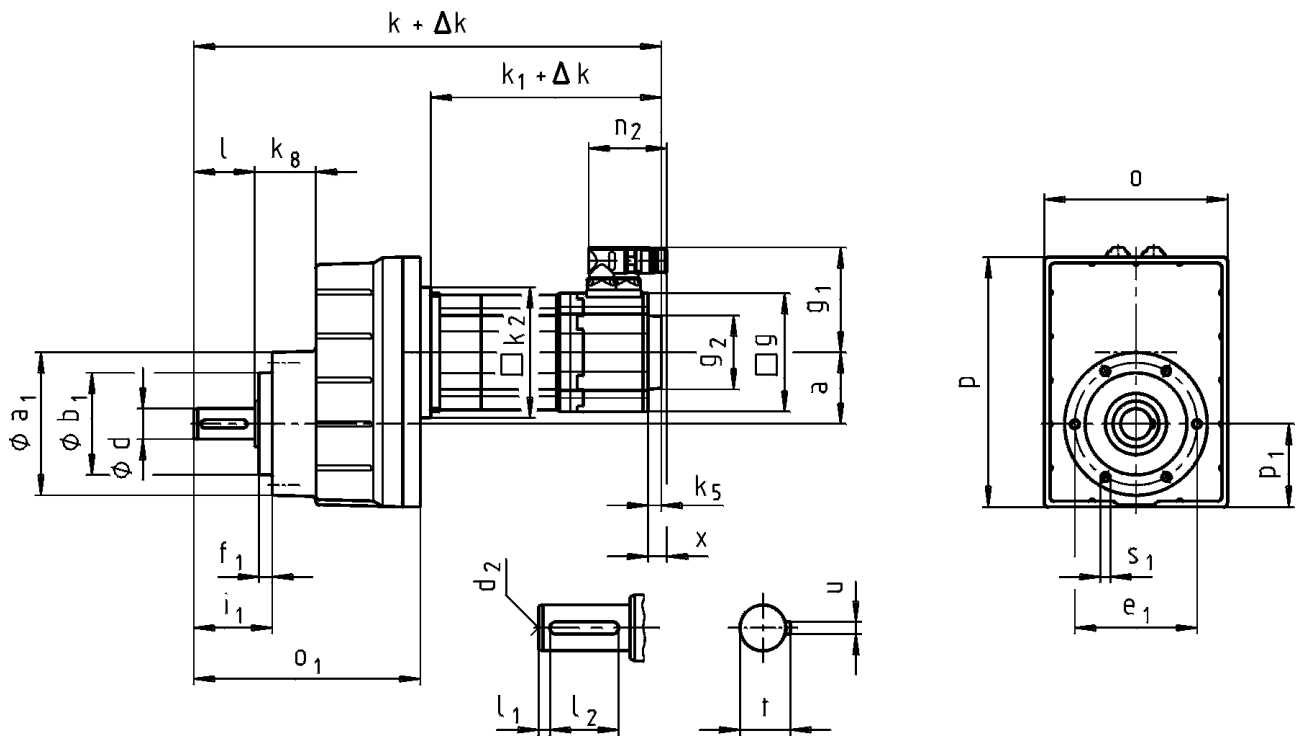

GST□□-1S VCR ... RSO

		06C C41	06F C41	06I C41	09D C41	09F C38	09H C41	09L C41	12D C20	12D C41	12H C15	12H C30	12H C35	12L C20	12L C41		
GST04...	k	279	309	339	331	351	371	411									
GST05...	k	300	330	360	352	372	392	432	369			409			449		
GST06...	k	323	353	383	375	395	415	455	392			432			472		
GST07...	k				404	424	444	484	421			461			501		
GST09...	k								464			504			544		
...RSO B0 ¹⁾	Δ k	0															
...RSO P□ ¹⁾	Δ k	19				20											
	k ₁	132	162	192	183	203	223	263	188			228			268		
	k ₂	66			91							118					
	g	62			89							116					
...RSO	k ₅	0			13							14					
	g ₂	□ 62			Ø 67							Ø 72					
	g ₁	76			90							105					
	n ₂	64								78							
	x					21								18			

¹⁾ → □ 801 - SRS / SRM / ECN / EQN / EQI / C20

²⁾ GST05: 12DC20 ... 12LC41

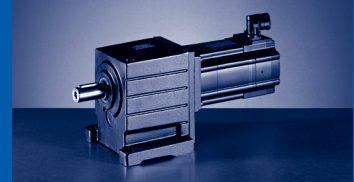

GST□□-1S VCR ... RSO

		14D C15	14D C36	14H C15	14H C32	14L C15	14L C32	14P C14	14P C32	19F C14	19F C30	19J C14	19J C30	19P C14	19P C30	
GST06...	k	408		448		488		528								
GST07...	k	437		477		517		557		476		516		576		
GST09...	k	480		520		560		600		519		559		619		
...RSO B0 ¹⁾	Δ k	0														
...RSO P□ ¹⁾	Δ k	28						34			44					
	k ₁	201		241		281		321		220		260		320		
	k ₂	145						195								
	g	143						192								
...RSO	k ₅	24						15								
	g ₂	Ø 78														
	g ₁	116				147	116	147	141	172	141	172	141	172	141	172
	n ₂	78				94	78	94	78	94	78	94	78	94	78	94
	x	16				38	16	38	16	36	16	36	16	36	16	36

¹⁾ → 801 - SRS / SRM / ECN / EQN / EQI / C20

GST□□-1S VCR

	o	o ₁	p	p ₁	a	k _g
GST04...	100	134	129	41	36	35
GST05...	115	165	156	51	45	43
GST06...	145	191	194	63	56	48
GST07...	180	223	245	82	70	60
GST09...	222	271	304	101	89	74

	d	l	l ₁	l ₂	d ₂	u	t	a ₁	b ₁	e ₁	f ₁	i ₁	s ₁
									h7				6x60°
GST04...	16	32	6	20	M5	5	18	72	48	61	8	43	M5x10
GST05...	20	40		28	M6	6	22.5	88	58	74	9	52	M6x12
GST06...	25	50	4	40	M10	8	28	109	70	90	11	64	M8x14
GST07...	30	60	7.5	45			33	140	100	120	13	77	M10x18
GST09...	40	80	8.5	63	M16	12	43	174	120	145	15	100	M12x20

d ≤ 50 mm: k6; d > 50 mm: m6

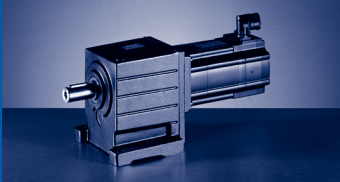

GST [mm]

GST□□-1S (MCS)

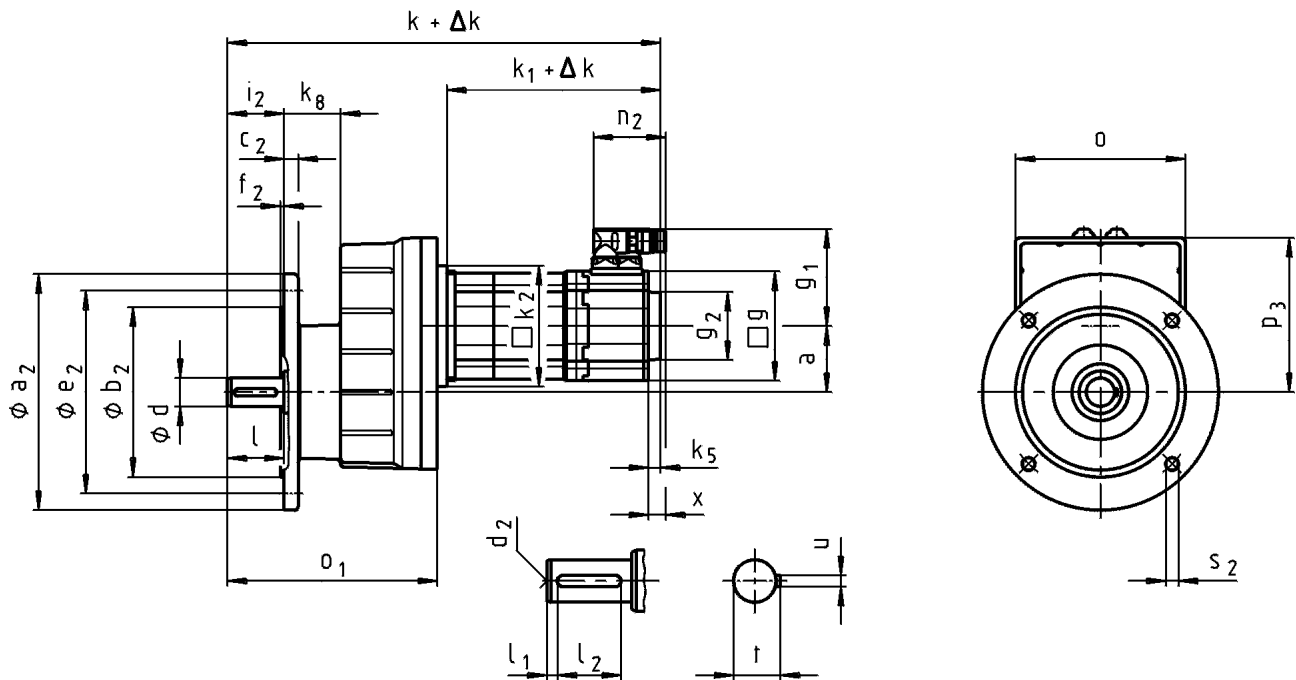

GST□□-1S VCK ... RSO

		06C C41	06F C41	06I C41	09D C41	09F C38	09H C41	09L C41	12D C20	12D C41	12H C15	12H C30	12H C35	12L C20	12L C41
GST04...	k	279	309	339	331	351	371	411							
GST05...	k	300	330	360	352	372	392	432	369			409			449
GST06...	k	323	353	383	375	395	415	455	392			432			472
GST07...	k				404	424	444	484	421			461			501
GST09...	k								464			504			544
...RSO B0 ¹⁾	Δ k	0													
...RSO P□ ¹⁾	Δ k	19				20									
	k ₁	132	162	192	183	203	223	263	188			228			268
	k ₂	66			91								118	145 ²⁾	
	g	62			89								116		
...RSO	k ₅	0			13								14		
	g ₂	□ 62			Ø 67								Ø 72		
	g ₁	76			90								105		
	n ₂	64							78						
	x					21								18	

¹⁾ → 801 - SRS / SRM / ECN/ EQN / EQI / C20

²⁾ GST05: 12DC20 ... 12LC41

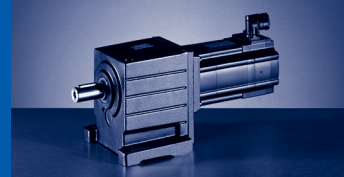

GST□□-1S VCK ... RSO

		14D C15	14D C36	14H C15	14H C32	14L C15	14L C32	14P C14	14P C32	19F C14	19F C30	19J C14	19J C30	19P C14	19P C30				
GST06...	k	408		448		488		528											
GST07...	k	437		477		517		557		476		516		576					
GST09...	k	480		520		560		600		519		559		619					
...RSO B0 ¹⁾	Δ k	0																	
...RSO P□ ¹⁾	Δ k	28						34			44								
	k ₁	201		241		281		321		220		260		320					
	k ₂	145						195											
	g	143						192											
...RSO	k ₅	24						15											
	g ₂	Ø 78																	
	g ₁	116				147		116		147		141		172		141		172	
	n ₂	78				94		78		94		78		94		78		94	
	x	16				38		16		38		16		36		16		36	

1) → 801 - SRS / SRM / ECN / EQN / EQI / C20

GST□□-1S VCK

	o	o ₁	p ₁	p ₃	a	k _g
GST04...	100	134	41	88	36	35
GST05...	115	165	51	105	45	43
GST06...	145	191	63	131	56	48
GST07...	180	223	82	164	70	60
GST09...	222	271	101	204	89	74

	d	l	l ₁	l ₂	d ₂	u	t	a ₂	b ₂	c ₂	e ₂	f ₂	i ₂	s ₂
									j7					4x90°
GST04...	16	32	6	20	M5	5	18	120	80	10	100	3	32	7
								140	95		115			9
								160	110		130			3.5
GST05...	20	40	6	28	M6	6	22.5	120	80	10	100	3	40	7
								140	95		115			9
								160	110		130			3.5
GST06...	25	50	4	40	M10	8	28	160	110	12	130	3.5	50	9
								200	130		165			11
								200	130		14			165
GST07...	30	60	7.5	45	M10	8	33	250	180	15	215	4	60	13.5
								300	230		16			265
GST09...	40	80	8.5	63	M16	12	43	250	180	16	215	4	80	13.5
								300	230		18			265

d ≤ 50 mm: k6; d > 50 mm: m6

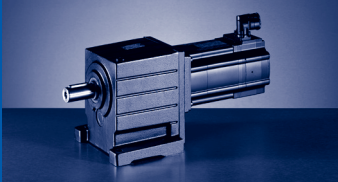

GST [mm]

GST□□-2S (MCS)

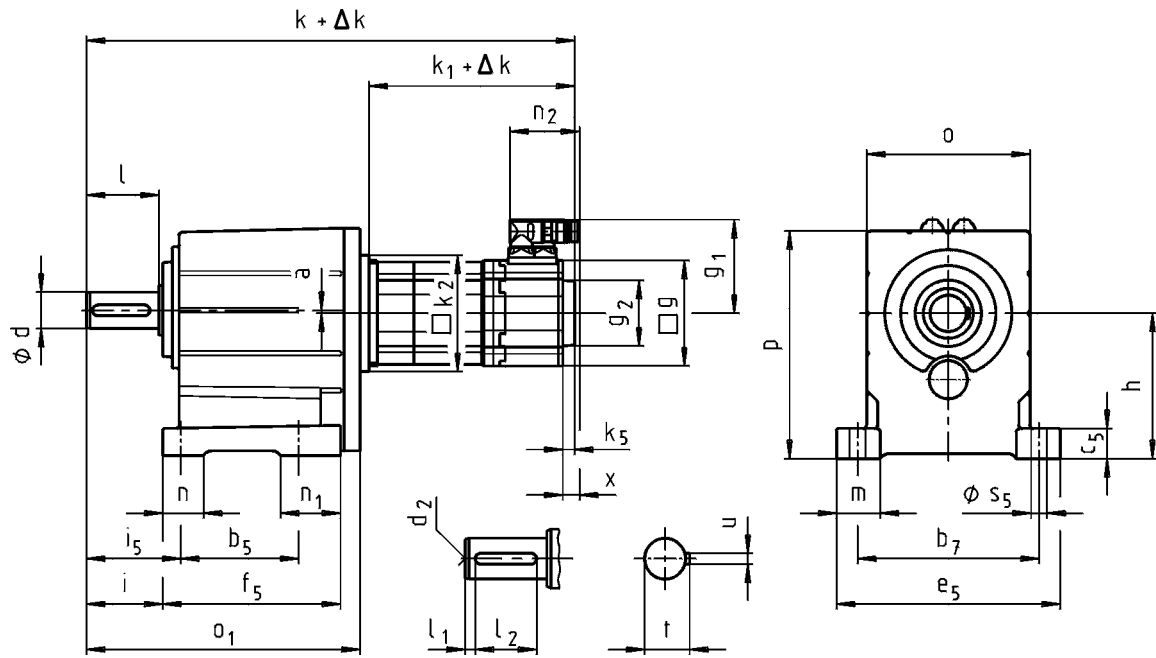

GST□□-2S VBR ... RSO

		06C C41	06F C41	06I C41	09D C41	09F C38	09H C41	09L C41	12D C20	12D C41	12H C15	12H C30	12H C35	12L C20	12L C41	
GST03...	k	279 ²⁾	309 ²⁾	339 ²⁾												
	k	291 ³⁾	321 ³⁾	351 ³⁾												
GST04...	k	319	349	379	371	391	411	451								
GST05...	k	349	379	409	401	421	441	481	418		458			498		
GST06...	k	375	405	435	427	447	467	507	444		484			524		
GST07...	k				483	503	523	563	500		540			580		
GST09...	k								563		603			643		
...RSO BO ¹⁾	Δ k	0														
...RSO P□ ¹⁾	Δ k	19				0							20			
	k ₁	132	162	192	183	203	223	263	188		228			268		
	k ₂	66			91									118		
	g	62			89									116		
...RSO	k ₅	0			13									14		
	g ₂	□ 62			Ø 67									Ø 72		
	g ₁	76			90									105		
	n ₂	64			78											
	x	21							18							

1) → □ 801 - SRS / SRM / ECN / EQN / EQI / C20

2) d = 14

3) d = 20

4) GST05: 12DC20 ... 12LC41

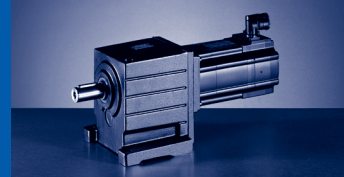

GST□□-2S VBR ... RSO

		14D C15	14D C36	14H C15	14H C32	14L C15	14L C32	14P C14	14P C32	19F C14	19F C30	19J C14	19J C30	19P C14	19P C30	
GST06...	k	460		500		540		580								
GST07...	k	516		556		596		636		555		595		655		
GST09...	k	579		619		659		699		618		658		718		
GST11...	k	636		676		716		756		675		715		775		
GST14...	k									765		805		865		
...RSO B0 ¹⁾	Δ k	0														
...RSO P□ ¹⁾	Δ k	28						34			44					
	k ₁	201		241		281		321		220		260		320		
	k ₂	145						195								
	g	143						192								
...RSO	k ₅	24						15								
	g ₂	Ø 78														
	g ₁	116				147	116	147	141	172	141	172	141	172	141	172
	n ₂	78				94	78	94	78	94	78	94	78	94	78	94
	x	16				38	16	38	16	36	16	36	16	36	16	36

¹⁾ → 801 - SRS / SRM / ECN / EQN / EQI / C20

GST□□-2S VBR

	o	o ₁	p	h	a
GST03...	90	127 ²⁾ 139 ³⁾	101	65	2
GST04...	100	174	132	80	0
GST05...	115	214	159	100	1
GST06...	145	243	198	125	2
GST07...	180	302	251	160	3
GST09...	222	370	311	200	4
GST11...	270	433	385	250	4
GST14...	328	533	479	315	6

²⁾ d = 14

³⁾ d = 20

	d	l	l ₁	l ₂	d ₂	u	t	b ₅	b ₇	c ₅	e ₅	f ₅	i	i ₅	m	n	n ₁	s ₅
GST03...	14	28	4	20	M5	5	16	60	91	11	105	84	34	40	20	-	-	6.6
													46	52				
GST04...	20	40	5	28	M6	6	22.5	76	105	18	129	112	43	53	25	20	36	9
GST05...	25	50	4	40	M10	8	28	90	125	23	155	139	53	66	33	26	49	11
GST06...	30	60	6	45				33	106	160	28	196	157	64	79	38	35	52
GST07...	40	80	7	63	M16	12	43	130	200	34	247	196	84	104	49	45	66	18
GST09...	50	100	8	80				14	53.5	165	245	44	298	239	105	127.5	54	
GST11...	60	120		100	M20	18	64	200	300	54	368	280	125	155	69	65	80	22
GST14...	80	160	15	125														

d ≤ 50 mm: k6; d > 50 mm: m6

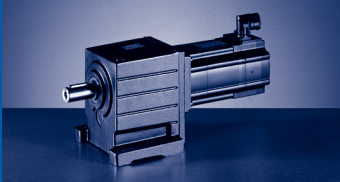

GST [mm]

GST□□-2S (MCS)

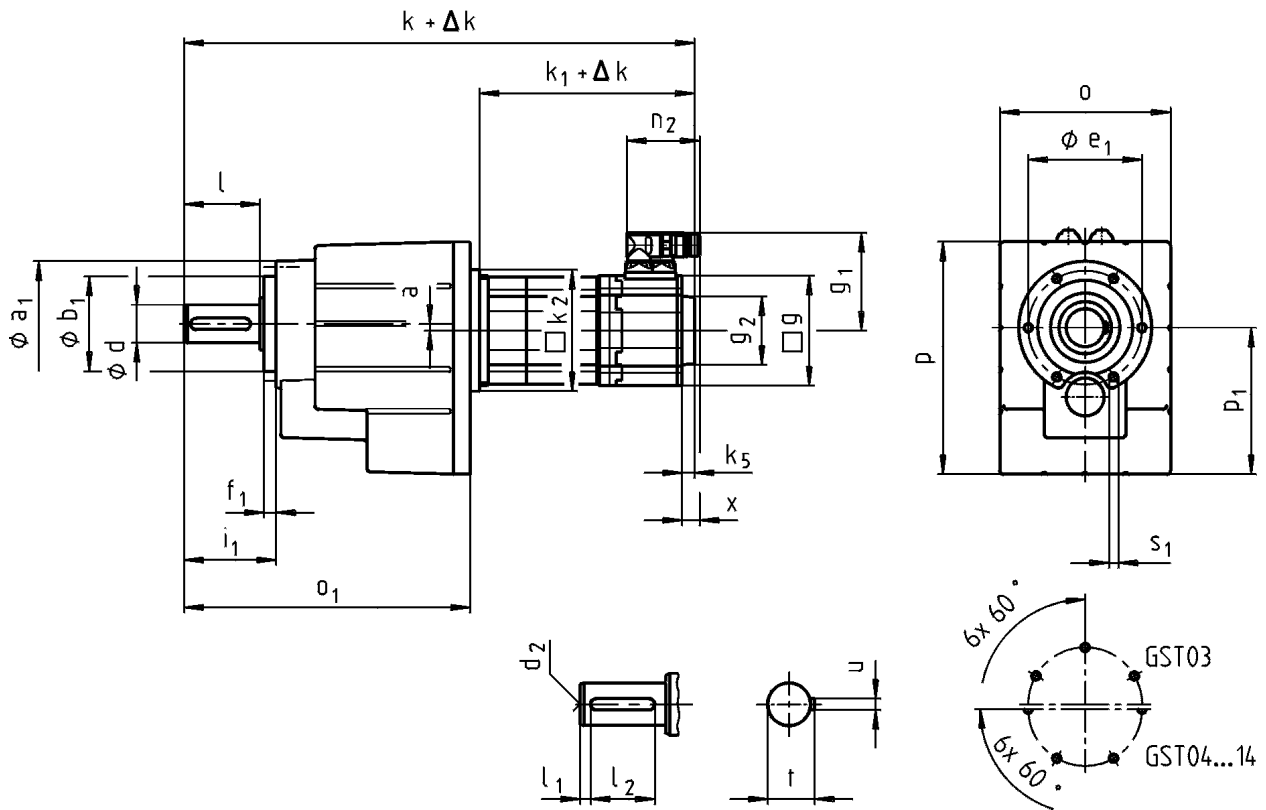

GST□□-2S VCR ... RSO

		06C C41	06F C41	06I C41	09D C41	09F C38	09H C41	09L C41	12D C20	12D C41	12H C15	12H C30	12H C35	12L C20	12L C41	
GST03...	k	279 ²⁾	309 ²⁾	339 ²⁾												
	k	291 ³⁾	321 ³⁾	351 ³⁾												
GST04...	k	319	349	379	371	391	411	451								
GST05...	k	349	379	409	401	421	441	481	418			458			498	
GST06...	k	375	405	435	427	447	467	507	444			484			524	
GST07...	k				483	503	523	563	500			540			580	
GST09...	k								563			603			643	
...RSO B0 ¹⁾	Δk	0														
...RSO P□ ¹⁾	Δk	19				20										
...RSO	k_1	132	162	192	183	203	223	263	188			228			268	
	k_2	66			91				118				145 ⁴⁾			
	g	62				89				116						
	k_5	0				13				14						
	g_2	□ 62				Ø 67				Ø 72						
	g_1	76				90				105						
	n_2	64				78										
x	21								18							

¹⁾ → 801 - SRS / SRM / ECN / EQN / EQ / C20

²⁾ d = 14

³⁾ d = 20

⁴⁾ GST05: 12DC20 ... 12LC41

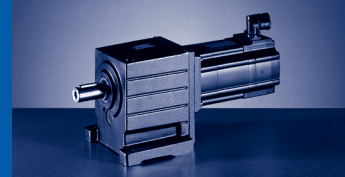

GST□□-2S VCR ... RSO

		14D C15	14D C36	14H C15	14H C32	14L C15	14L C32	14P C14	14P C32	19F C14	19F C30	19J C14	19J C30	19P C14	19P C30	
GST06...	k	460		500		540		580								
GST07...	k	516		556		596		636		555		595		655		
GST09...	k	579		619		659		699		618		658		718		
GST11...	k	636		676		716		756		675		715		775		
GST14...	k									765		805		865		
...RSO B0 ¹⁾	Δ k	0														
...RSO P□ ¹⁾	Δ k	28						34			44					
	k ₁	201		241		281		321		220		260		320		
	k ₂	145						195								
	g	143						192								
...RSO	k ₅	24						15								
	g ₂	Ø 78														
	g ₁	116				147	116	147	141	172	141	172	141	172	141	172
	n ₂	78				94	78	94	78	94	78	94	78	94	78	94
	x	16				38	16	38	16	36	16	36	16	36	16	36

¹⁾ →  801 - SRS / SRM / ECN / EQN / EQI / C20

GST□□-2S VCR

	o	o ₁	p	p ₁	a
GST03...	90	127 ²⁾ 139 ³⁾	100	64	2
GST04...	100	174	129	77	0
GST05...	115	214	156	98	1
GST06...	145	243	194	121	2
GST07...	180	302	245	155	3
GST09...	222	370	304	194	4
GST11...	270	433	378	243	
GST14...	328	533	470	306	6

²⁾ d = 14

³⁾ d = 20

	d	l	l ₁	l ₂	d ₂	u	t	a ₁	b ₁	e ₁	f ₁	i ₁	s ₁
									h7				6x60°
GST03...	14	28	4	20	M5	5	16	71	48	61	8	39	M5x10
GST04...	20	40	5	28	M6	6	22.5	72				51	
GST05...	25	50	4	40	M10	8	28	88	58	74	9	62	M6x12
GST06...	30	60	6	45			33	109	70	90	10	74	M8x14
GST07...	40	80	7	63	M16	12	43	140	100	120	13	97	M10x18
GST09...	50	100	8	80			14	53.5	174	120	145	15	120
GST11...	60	120		100	M20	18	64	215	150	185	18	143	M16x26
GST14...	80	160	15	125				22	85	265	195	230	22

d ≤ 50 mm: k6; d > 50 mm: m6

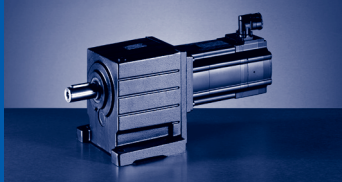

GST [mm]

GST□□-2S (MCS)

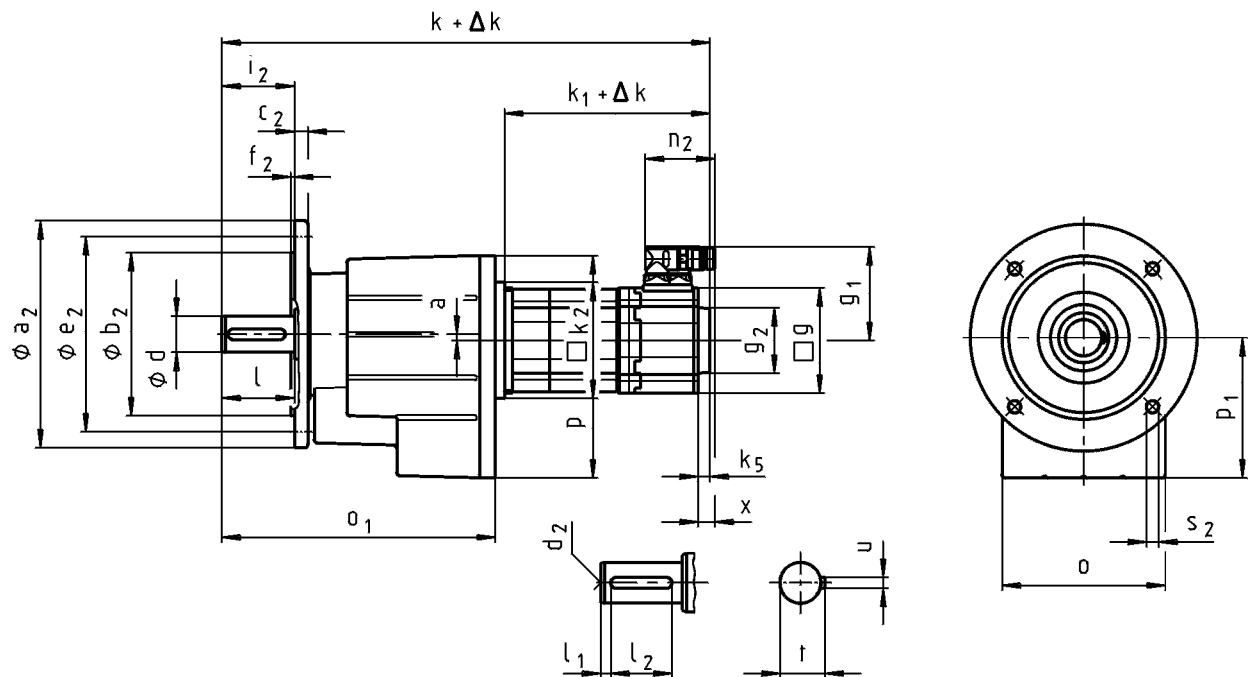

GST□□-2S VCK ... RSO

		06C C41	06F C41	06I C41	09D C41	09F C38	09H C41	09L C41	12D C20	12D C41	12H C15	12H C30	12H C35	12L C20	12L C41	
GST03...	k	279 ²⁾	309 ²⁾	339 ²⁾												
	k	291 ³⁾	321 ³⁾	351 ³⁾												
GST04...	k	319	349	379	371	391	411	451								
GST05...	k	349	379	409	401	421	441	481	418			458			498	
GST06...	k	375	405	435	427	447	467	507	444			484			524	
GST07...	k				483	503	523	563	500			540			580	
GST09...	k								563			603			643	
...RSO B0 ¹⁾	Δ k	0														
...RSO P□ ¹⁾	Δ k	19			20											
	k ₁	132	162	192	183	203	223	263	188			228			268	
	k ₂	66			91						118 145 ⁴⁾					
	g	62			89						116					
...RSO	k ₅	0			13						14					
	g ₂	□ 62			Ø 67						Ø 72					
	g ₁	76			90						105					
	n ₂	64									78					
	x				21						18					

¹⁾ → 801 - SRS / SRM / ECN/ EQN / EQI / C20

²⁾ d = 14

³⁾ d = 20

⁴⁾ GST05: 12DC20 ... 12LC41

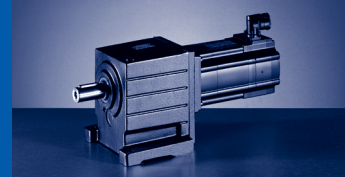

GST□□-2S VCK ... RSO

		14D C15	14D C36	14H C15	14H C32	14L C15	14L C32	14P C14	14P C32	19F C14	19F C30	19J C14	19J C30	19P C14	19P C30				
GST06...	k	460		500		540		580											
GST07...	k	516		556		596		636		555		595		655					
GST09...	k	579		619		659		699		618		658		718					
GST11...	k	636		676		716		756		675		715		775					
GST14...	k									765		805		865					
...RSO B0 ¹⁾	Δ k	0																	
...RSO P□ ¹⁾	Δ k	28						34			44								
	k ₁	201		241		281		321		220		260		320					
	k ₂	145						195											
	g	143						192											
...RSO	k ₅	24						15											
	g ₂	Ø 78																	
	g ₁	116				147		116		147		141		172		141		172	
	n ₂	78				94		78		94		78		94		78		94	
	x	16				38		16		38		16		36		16		36	

1) → 801 - SRS / SRM / ECN / EQN / EQI / C20

GST□□-2S VCK

	o	o ₁	p	p ₁	a	d	l	l ₁	l ₂	d ₂	u	t
GST03...	90	127 ²⁾ 139 ³⁾	100	64	2	14	28	4	20	M5	5	16
GST04...	100	174	129	77	0	20	40	5	28	M6	6	22.5
GST05...	115	214	156	98	1	25	50	4	40	M10	8	28
GST06...	145	243	194	121	2	30	60	6	45			33
GST07...	180	302	245	155	3	40	80	7	63	M16	12	43
GST09...	222	370	304	194	4	50	100	8	80		14	53.5
GST11...	270	433	378	243		60	120		100	M20	18	64
GST14...	328	533	470	306	6	80	160	15	125		22	85

	a ₂	b ₂	c ₂	e ₂	f ₂	i ₂	s ₂		a ₂	b ₂	c ₂	e ₂	f ₂	i ₂	s ₂					
		j7					4x90°			j7					4x90°					
GST03...	120	80	10	100	3	28 ²⁾ 40 ³⁾	7	GST06...	160	110	12	130	3.5	60	9					
	140	95		115			9		200	130		165			11					
	160	110		130	3.5	250	180		15	215	80									
GST04...	120	80	10	100	3	40	7	GST07...	300	230	18	265	4	100	13.5					
	140	95		115			9									350	250	20	300	5
	160	110		130	3.5	350	250									22	300	5	160	18
GST05...	120	80	12	100	3	50	7	GST11...	400	300	24	350	5	160	18					
	140	95		115			9													
	160	110		130	3.5	9														
	200	130		165	3.5	11														

d ≤ 50 mm: k6; d > 50 mm: m6

²⁾ d = 14

³⁾ d = 20

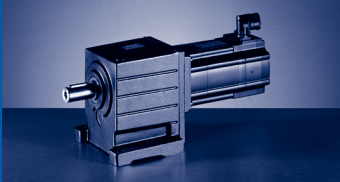

GST [mm]

GST□□-3S (MCS)

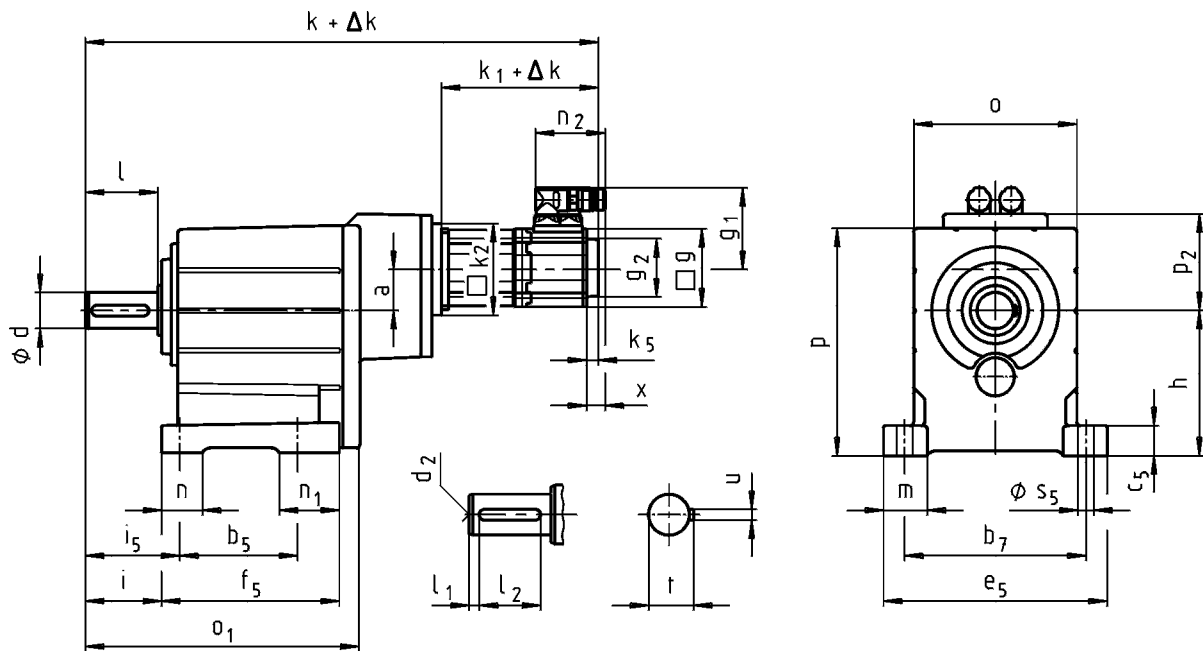

GST□□-3S VBR ... RSO

		06C C41	06F C41	06I C41	09D C41	09F C38	09H C41	09L C41	12D C20	12D C41	12H C15	12H C30	12H C35	12L C20	12L C41	
GST05...	k	425	455	485	478	498	518	558								
GST06...	k	468	498	528	521	541	561	601								
GST07...	k	535	565	595	588	608	628	668	605		645			685		
GST09...	k	616	646	676	669	689	709	749	686		726			766		
GST11...	k				745	765	785	825	762		802			842		
GST14...	k								886		926			966		
...RSO B0 ¹⁾	Δk	0														
...RSO P□ ¹⁾	Δk	19				20										
...RSO	k_1	132	162	192	183	203	223	263	188		228			268		
	k_2	66			91				118				145 ²⁾			
	g	62			89				116							
	k_5	0			13				14							
	g_2	□ 62			Ø 67				Ø 72							
	g_1	76			90				105							
	n_2	64							78							
	x					21				18						

¹⁾ → 801 - SRS / SRM / ECN / EQN / EQ / C20

²⁾ GST07: 12DC20 ... 12LC41

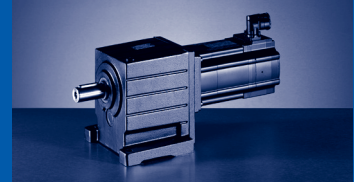

GST□□-3S VBR ... RSO

		14D C15	14D C36	14H C15	14H C32	14L C15	14L C32	14P C14	14P C32	19F C14	19F C30	19J C14	19J C30	19P C14	19P C30				
GST09...	k	701		741		781		821											
GST11...	k	777		817		857		897		816		856		916					
GST14...	k	901		941		981		1021		940		980		1040					
...RSO B0 ¹⁾	Δ k	0																	
...RSO P□ ¹⁾	Δ k	28						34			44								
	k ₁	201		241		281		321		220		260		320					
	k ₂	145						195											
	g	143						192											
...RSO	k ₅	24						15											
	g ₂	Ø 78																	
	g ₁	116				147		116		147		141		172		141		172	
	n ₂	78				94		78		94		78		94		78		94	
	x	16				38		16		38		16		36		16		36	

¹⁾ → 801 - SRS / SRM / ECN / EQN / EQI / C20

GST□□-3S VBR

	o	o ₁	p	p ₂	h	a
GST05...	115	208	159	87	100	35
GST06...	145	240	198		125	34
GST07...	180	302	251	103	160	42
GST09...	222	370	311	129	200	52
GST11...	270	433	385	162	250	66
GST14...	328	533	479	200	315	83

	d	l	l ₁	l ₂	d ₂	u	t	b ₅	b ₇	c ₅	e ₅	f ₅	i	i ₅	m	n	n ₁	s ₅
GST05...	25	50	4	40	M10	8	28	90	125	23	155	139	53	66	33	26	49	11
GST06...	30	60	6	45			33	106	160	28	196	157	64	79	38	35	52	13.5
GST07...	40	80	7	63	M16	12	43	130	200	34	247	196	84	104	49	45	66	18
GST09...	50	100	8	80			14	53.5	165	245	44	298	239	105	127.5	54	48	
GST11...	60	120		100	M20	18	64	200	300	54	368	280	125	155	69	65	80	22
GST14...	80	160	15	125			22	85	250	380	65	460	340	165	200	85	85	91

d ≤ 50 mm: k6; d > 50 mm: m6

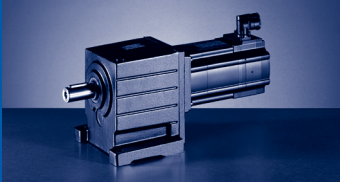

GST [mm]

GST□□-3S (MCS)

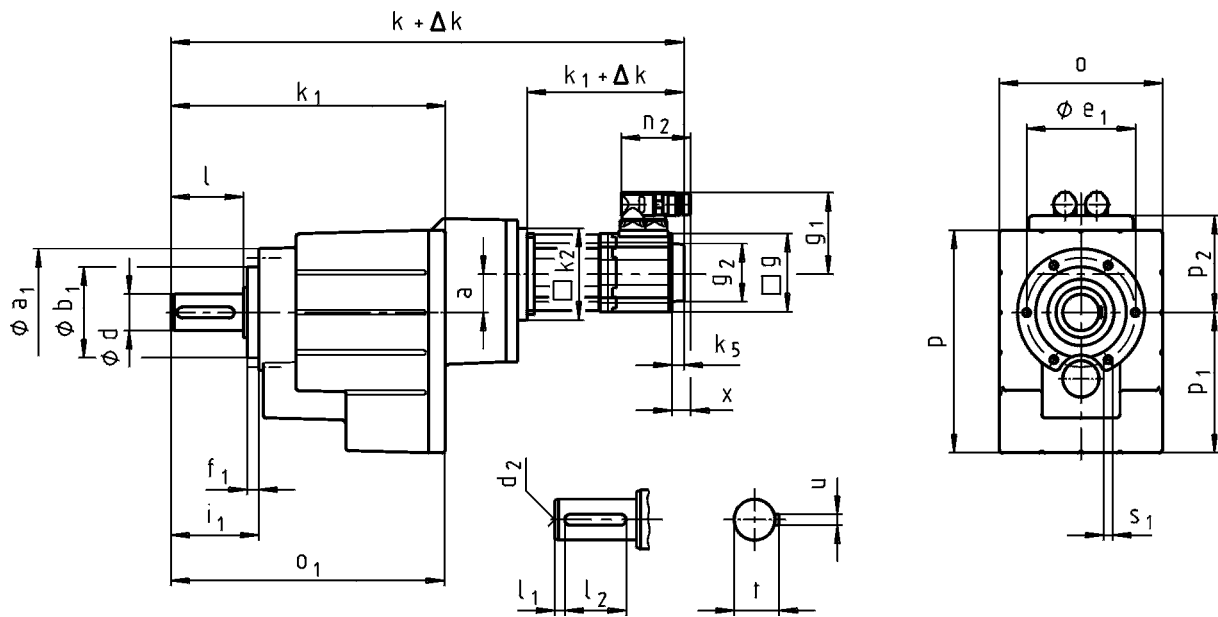

GST□□-3S VCR ... RSO

		06C C41	06F C41	06I C41	09D C41	09F C38	09H C41	09L C41	12D C20	12D C41	12H C15	12H C30	12H C35	12L C20	12L C41		
GST05...	k	425	455	485	478	498	518	558									
GST06...	k	468	498	528	521	541	561	601									
GST07...	k	535	565	595	588	608	628	668	605		645			685			
GST09...	k	616	646	676	669	689	709	749	686		726			766			
GST11...	k				745	765	785	825	762		802			842			
GST14...	k								886		926			966			
...RSO B0 ¹⁾	Δk	0															
...RSO P□ ¹⁾	Δk	19								20							
	k ₁	132	162	192	183	203	223	263	188		228			268			
	k ₂	66			91								118		145 ²⁾		
	g	62			89								116				
...RSO	k ₅	0			13								14				
	g ₂	□ 62			Ø 67								Ø 72				
	g ₁	76			90								105				
	n ₂	64							78								
	x				21								18				

¹⁾ → 801 - SRS / SRM / ECN / EQN / EQI / C20

²⁾ GST07: 12DC20 ... 12LC41



GST□□-3S VCR ... RSO

		14D C15	14D C36	14H C15	14H C32	14L C15	14L C32	14P C14	14P C32	19F C14	19F C30	19J C14	19J C30	19P C14	19P C30	
GST09...	k	701		741		781		821								
GST11...	k	777		817		857		897		816		856		916		
GST14...	k	901		941		981		1021		940		980		1040		
...RSO B0 ¹⁾	Δ k	0														
...RSO P□ ¹⁾	Δ k	28						34			44					
	k ₁	201		241		281		321		220		260		320		
	k ₂	145						195								
	g	143						192								
...RSO	k ₅	24						15								
	g ₂	Ø 78														
	g ₁	116				147	116	147	141	172	141	172	141	172	141	172
	n ₂	78				94	78	94	78	94	78	94	78	94	78	94
	x	16				38	16	38	16	36	16	36	16	36	16	36

1) → 801 - SRS / SRM / ECN / EQN / EQI / C20

GST□□-3S VCR

	o	o ₁	p	p ₁	p ₂	a
GST05...	115	208	156	98	87	35
GST06...	145	240	194	121		34
GST07...	180	302	245	155	103	42
GST09...	222	370	304	194	129	52
GST11...	270	433	378	243	162	66
GST14...	328	533	470	306	200	83

	d	l	l ₁	l ₂	d ₂	u	t	a ₁	b ₁	e ₁	f ₁	i ₁	s ₁
									h7				6x60°
GST05...	25	50	4	40	M10	8	28	88	58	74	9	62	M6x12
GST06...	30	60	6	45			33	109	70	90	10	74	M8x14
GST07...	40	80	7	63	M16	12	43	140	100	120	13	97	M10x18
GST09...	50	100	8	80			53.5	174	120	145	15	120	M12x20
GST11...	60	120		100	M20	18	64	215	150	185	18	143	M16x26
GST14...	80	160	125	22			85	265	195	230	22	187	M20x34

d ≤ 50 mm: k6; d > 50 mm: m6

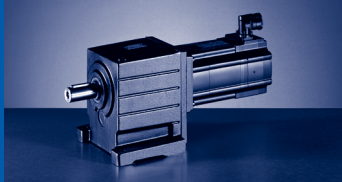

GST [mm]

GST□□-3S (MCS)

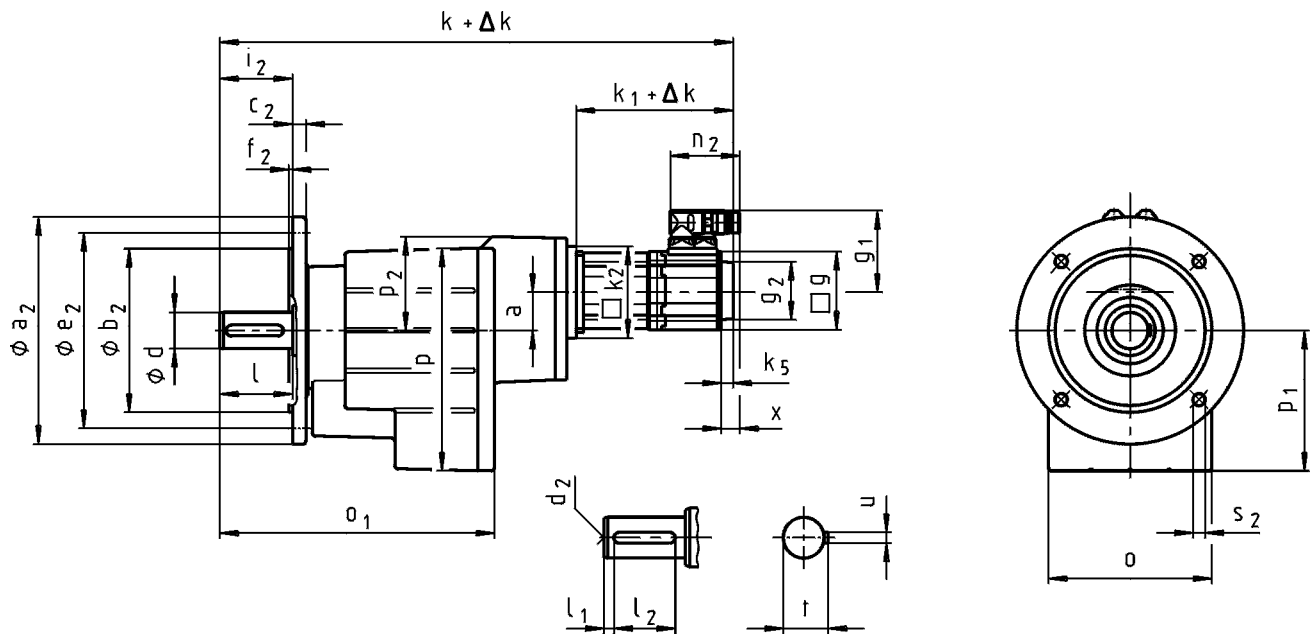

GST□□-3S VCK ... RSO

		06C C41	06F C41	06I C41	09D C41	09F C38	09H C41	09L C41	12D C20	12D C41	12H C15	12H C30	12H C35	12L C20	12L C41	
GST05...	k	425	455	485	478	498	518	558								
GST06...	k	468	498	528	521	541	561	601								
GST07...	k	535	565	595	588	608	628	668	605		645			685		
GST09...	k	616	646	676	669	689	709	749	686		726			766		
GST11...	k				745	765	785	825	762		802			842		
GST14...	k								886		926			966		
...RSO B0 ¹⁾	Δ k	0														
...RSO P□ ¹⁾	Δ k	19				20										
	k ₁	132	162	192	183	203	223	263	188		228			268		
	k ₂	66			91				118				145 ²⁾			
	g	62			89				116							
...RSO	k ₅	0			13				14							
	g ₂	□ 62			Ø 67				Ø 72							
	g ₁	76			90				105							
	n ₂	64							78							
	x					21				18						

¹⁾ → 801 - SRS / SRM / ECN / EQN / EQI / C20

²⁾ GST07: 12DC20 ... 12LC41

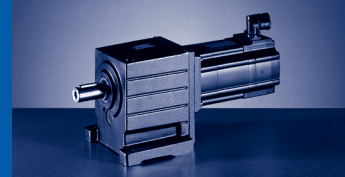

GST□□-3S VCK ... RSO

		14D C15	14D C36	14H C15	14H C32	14L C15	14L C32	14P C14	14P C32	19F C14	19F C30	19J C14	19J C30	19P C14	19P C30				
GST09...	k	701		741		781		821											
GST11...	k	777		817		857		897		816		856		916					
GST14...	k	901		941		981		1021		940		980		1040					
...RSO B0 ¹⁾	Δ k	0																	
...RSO P□ ¹⁾	Δ k	28						34			44								
	k ₁	201		241		281		321		220		260		320					
	k ₂	145						195											
	g	143						192											
...RSO	k ₅	24						15											
	g ₂	Ø 78																	
	g ₁	116				147		116		147		141		172		141		172	
	n ₂	78				94		78		94		78		94		78		94	
	x	16				38		16		38		16		36		16		36	

1) → 801 - SRS / SRM / ECN / EQN / EQI / C20

GST□□-3S VCK

	o	o ₁	p	p ₁	p ₂	a
GST05...	115	208	156	98	87	35
GST06...	145	240	194	121		34
GST07...	180	302	245	155	103	42
GST09...	222	370	304	194	129	52
GST11...	270	433	378	243	162	66
GST14...	328	533	470	306	200	83

	d	l	l ₁	l ₂	d ₂	u	t	a ₂	b ₂ j7	c ₂	e ₂	f ₂	i ₂	s ₂ 4x90°
GST05...	25	50	4	40	M10	8	28	120	80	10	100	3	50	7
								140	95		115			9
								160	110		130			11
								200	130		165			11
GST06...	30	60	6	45	M16	12	33	160	110	12	130	3.5	60	9
								200	130		165			11
GST07...	40	80	7	63	M16	12	43	250	180	15	215	4	80	13.5
GST09...	50	100	8	80	M20	14	53.5	300	230	18	265	4	100	14
								350	250		20			
GST11...	60	120	15	125	M20	18	64	400	300	22	300	5	120	18
								350	250		22			
GST14...	80	160	15	125	M20	22	85	400	300	24	350	5	160	18
								400	300		24			

d ≤ 50 mm: k6; d > 50 mm: m6

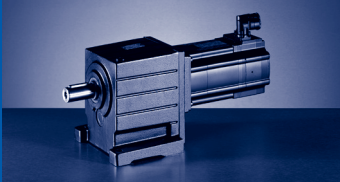

GST [mm]

GST□□-1A (MCA)

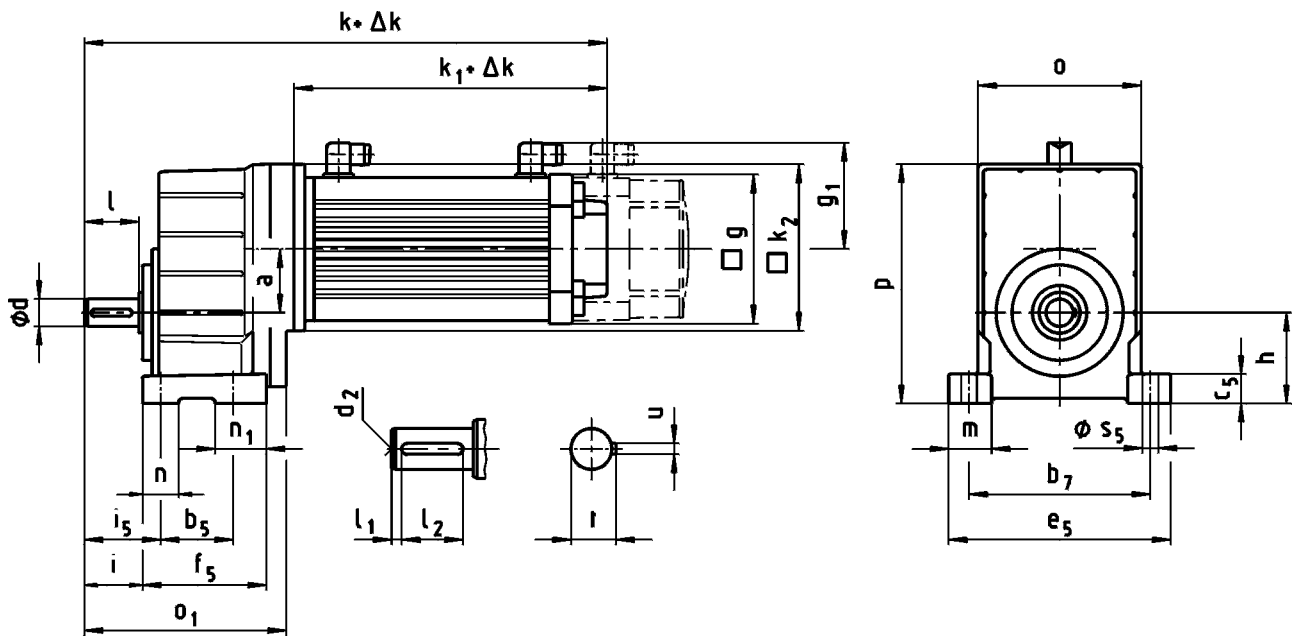

GST□□-1A VBR ... RSO

		10I C40 ...S00	13I C41 ...S00	13I C34 ...F10	14L C20 ...S00	14L C41 ...S00	14L C16 ...F10	14L C35 ...F10	17N C23 ...S00	17N C41 ...S00
GST04...	k	407	415	483						
GST05...	k	428	436	504	486		548			
GST06...	k	451	459	527	509		571		548	
GST07...	k	480	488	556	538		600		577	
GST09...	k				581		643		620	
...RSO B0 ¹⁾	Δk	0								
...RSO P□ ¹⁾	Δk	25	35			33			35	
	k_1	258	267	335	307		369		346	
	k_2	145				180				
	g	102	131			142			165	
	g_1	90	102			109			118	

¹⁾ → 803 - SRS / SRM / ECN / EQN / EQI / S20 / T20 / CDD

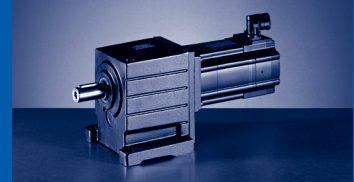

GST□□-1A VBR ... RSO

		17N C17 ...F10	17N C35 ...F10	19S C23 ...S00	19S C42 ...S00	19S C17 ...F10	19S C35 ...F10	21X C25 ...S00	21X C42 ...S00	21X C17 ...F10	21X C35 ...F10
GST06...	k	637									
GST07...	k	666		646		743		724		820	
GST09...	k	709		689		786		767		863	
...RSO B0 ¹⁾	Δ k	0									
...RSO P□ ¹⁾	Δ k	35		38				42			
	k ₁	435		408		505		479		575	
	k ₂	180		222				265			
	g	165		192				214			
	g ₁	118		161				172			

¹⁾ →  803 - SRS / SRM / ECN / EQN / EQI / S20 / T20 / CDD

GST□□-1A VBR

	o	o ₁	p	h	a
GST04...	100	134	138	50	36
GST05...	115	165	168	63	45
GST06...	145	191	211	80	56
GST07...	180	223	264	100	70
GST09...	222	271	329	125	89

	d	l	l ₁	l ₂	d ₂	u	t	b ₅	b ₇	c ₅	e ₅	f ₅	i	i ₅	m	n	n ₁	s ₅
GST04...	16	32	6	20	M5	5	18	55	105	17	128	80	35	45	24	20	25	9
GST05...	20	40		28	M6	6	22.5	70	125	22	154	99	43	56	32	26	29	11
GST06...	25	50	4	40	M10	8	28	72	160	27	194	115	53	68	37	30	43	13.5
GST07...	30	60	7.5	45			33	80	200	35	245	137	64	84	48	40	57	18
GST09...	40	80	8.5	63	M16	12	43	105	245	43	296	161	84	107	51	45	56	

d ≤ 50 mm: k6; d > 50 mm: m6

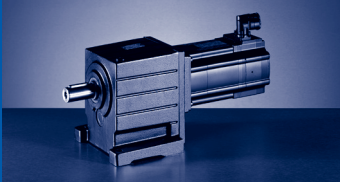

GST [mm]

GST□□-1A (MCA)

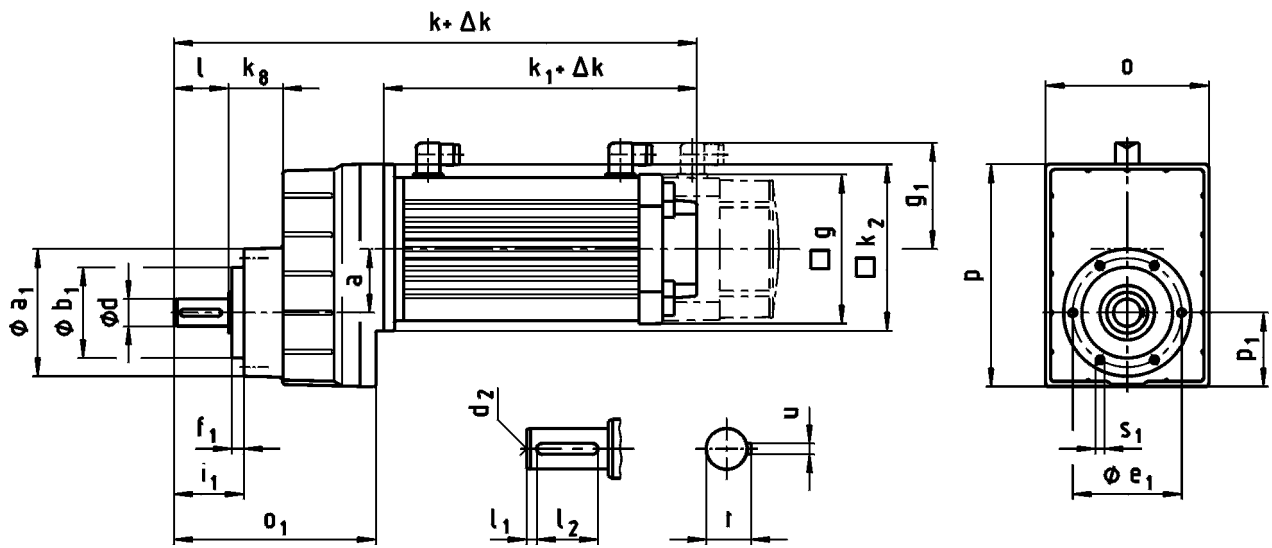

GST□□-1A VCR ... RSO

		10I C40 ...S00	13I C41 ...S00	13I C34 ...F10	14L C20 ...S00	14L C41 ...S00	14L C16 ...F10	14L C35 ...F10	17N C23 ...S00	17N C41 ...S00
GST04...	k	407	415	483						
GST05...	k	428	436	504		486		548		
GST06...	k	451	459	527		509		571		548
GST07...	k	480	488	556		538		600		577
GST09...	k					581		643		620
...RSO B0 ¹⁾	Δk					0				
...RSO P□ ¹⁾	Δk	25	35			33				35
	k_1	258	267	335		307		369		346
	k_2		145					180		
	g	102	131			142				165
	g_1	90	102			109				118

¹⁾ → 803 - SRS / SRM / ECN / EQN / EQI / S20 / T20 / CDD

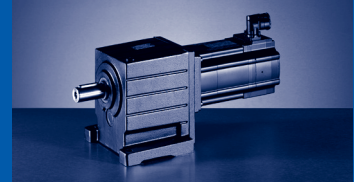

GST□□-1A VCR ... RSO

		17N C17 ...F10	17N C35 ...F10	19S C23 ...S00	19S C42 ...S00	19S C17 ...F10	19S C35 ...F10	21X C25 ...S00	21X C42 ...S00	21X C17 ...F10	21X C35 ...F10
GST06...	k	637									
GST07...	k	666		646		743		724		820	
GST09...	k	709		689		786		767		863	
...RSO B0 ¹⁾	Δ k	0									
...RSO P□ ¹⁾	Δ k	35		38				42			
	k ₁	435		408		505		479		575	
	k ₂	180				222		265			
	g	165				192		214			
	g ₁	118				161		172			

¹⁾ →  803 - SRS / SRM / ECN / EQN / EQI / S20 / T20 / CDD

GST□□-1A VCR

	o	o ₁	p		p ₁		a	k _g	
GST04...	100	134	129		41		36	35	
GST05...	115	165	156		51		45	43	
GST06...	145	191	194		63		56	48	
GST07...	180	223	245		82		70	60	
GST09...	222	271	304		101		89	74	

	d	l	l ₁	l ₂	d ₂	u	t	a ₁	b ₁	e ₁	f ₁	i ₁	s ₁
									h7				6x60°
GST04...	16	32	6	20	M5	5	18	72	48	61	8	43	M5x10
GST05...	20	40		28	M6	6	22.5	88	58	74	9	52	M6x12
GST06...	25	50	4	40	M10	8	28	109	70	90	11	64	M8x14
GST07...	30	60	7.5	45			33	140	100	120	13	77	M10x18
GST09...	40	80	8.5	63	M16	12	43	174	120	145	15	100	M12x20

d ≤ 50 mm: k6; d > 50 mm: m6

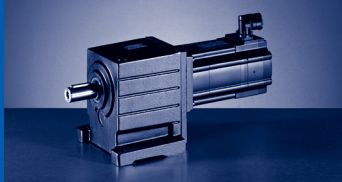

GST [mm]

GST□□-1A (MCA)

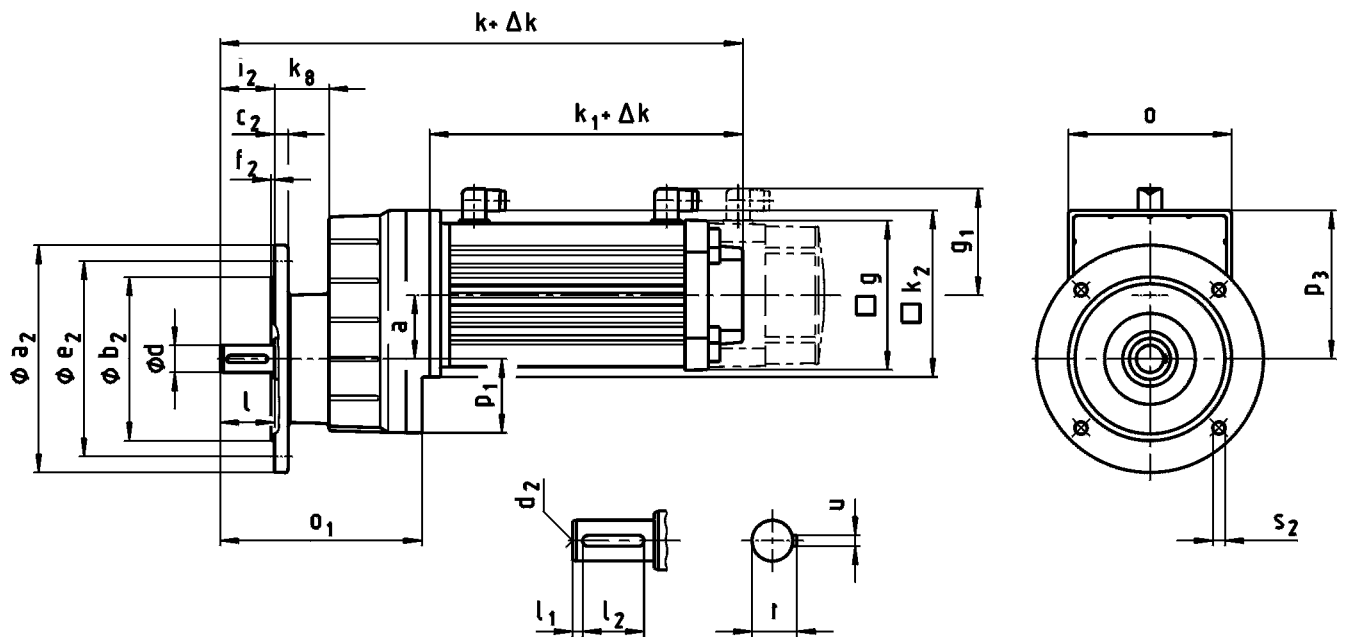

GST□□-1A VCK ... RSO

		10I C40 ...S00	13I C41 ...S00	13I C34 ...F10	14L C20 ...S00	14L C41 ...S00	14L C16 ...F10	14L C35 ...F10	17N C23 ...S00	17N C41 ...S00
GST04...	k	407	415	483						
GST05...	k	428	436	504	486		548			
GST06...	k	451	459	527	509		571		548	
GST07...	k	480	488	556	538		600		577	
GST09...	k				581		643		620	
...RSO B0 ¹⁾	Δk	0								
...RSO P□ ¹⁾	Δk	25	35			33			35	
	k_1	258	267	335	307		369		346	
	k_2	145				180				
	g	102	131			142			165	
	g_1	90	102			109			118	

¹⁾ → 803 - SRS / SRM / ECN / EQN / EQI / S20 / T20 / CDD



GST□□-1A VCK ... RSO

		17N C17 ...F10	17N C35 ...F10	19S C23 ...S00	19S C42 ...S00	19S C17 ...F10	19S C35 ...F10	21X C25 ...S00	21X C42 ...S00	21X C17 ...F10	21X C35 ...F10
GST06...	k	637									
GST07...	k	666		646		743		724		820	
GST09...	k	709		689		786		767		863	
...RSO B0 ¹⁾	Δ k	0									
...RSO P□ ¹⁾	Δ k	35		38				42			
	k ₁	435		408		505		479		575	
	k ₂	180		222				265			
	g	165		192				214			
	g ₁	118		161				172			

1) → 803 - SRS / SRM / ECN / EQN / EQI / S20 / T20 / CDD

GST□□-1A VCK

	o	o ₁	p ₁	p ₃	a	k ₈
GST04...	100	134	41	88	36	35
GST05...	115	165	51	105	45	43
GST06...	145	191	63	131	56	48
GST07...	180	223	82	164	70	60
GST09...	222	271	101	204	89	74

	d	l	l ₁	l ₂	d ₂	u	t	a ₂	b ₂	c ₂	e ₂	f ₂	i ₂	s ₂
									j7					4x90°
GST04...	16	32	6	20	M5	5	18	120	80	10	100	3	32	7
140								95	115		9			
160								110	130		3.5			9
GST05...	20	40	6	28	M6	6	22.5	120	80	12	100	3	40	7
140								95	115		9			
160								110	130		11			
200								130	165		11			
GST06...	25	50	4	40	M10	8	28	160	110	14	130	3.5	50	9
200								130	165		11			
GST07...	30	60	7.5	45	M10	8	33	250	180	15	215	4	60	13.5
GST09...								40	80		8.5			63

d ≤ 50 mm: k6; d > 50 mm: m6

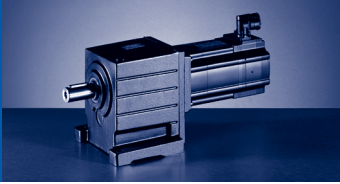

GST [mm]

GST□□-2A (MCA)

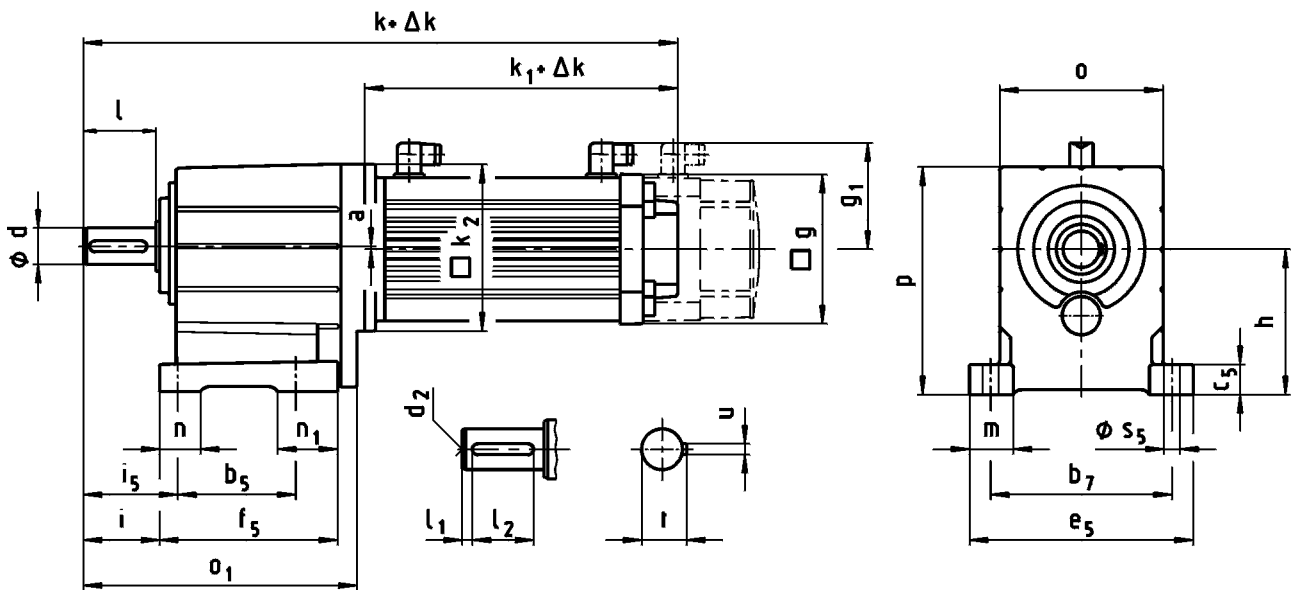

GST□□-2A VBR ... RSO

		10I C40 ...S00	13I C41 ...S00	13I C34 ...F10	14L C20 ...S00	14L C41 ...S00	14L C16 ...F10	14L C35 ...F10	17N C23 ...S00	17N C41 ...S00
GST04...	k	447	455	523						
GST05...	k	477	485	553	535		597			
GST06...	k	503	511	579	561		623		600	
GST07...	k	559	567	635	617		679		656	
GST09...	k				680		742		719	
GST11...	k				737		799		776	
...RSO B0 ¹⁾	Δk					0				
...RSO P□ ¹⁾	Δk	25	35			33			35	
	k_1	258	267	335	307		369		346	
	k_2		145				180			
	g	102	131			142			165	
	g_1	90	102			109			118	

¹⁾ → 803 - SRS / SRM / ECN / EQN / EQI / S20 / T20 / CDD

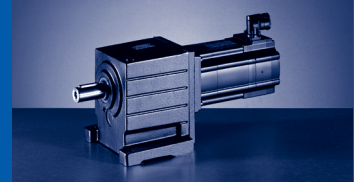

GST□□-2A VBR ... RSO

		17N C17 ...F10	17N C35 ...F10	19S C23 ...S00	19S C42 ...S00	19S C17 ...F10	19S C35 ...F10	21X C25 ...S00	21X C42 ...S00	21X C17 ...F10	21X C35 ...F10
GST06...	k	689									
GST07...	k	745		725		822		803		899	
GST09...	k	808		788		885		866		962	
GST11...	k	865		845		942		923		1019	
GST14...	k			935		1032		1013		1109	
...RSO B0 ¹⁾	Δ k	0									
...RSO P□ ¹⁾	Δ k	35				38				42	
	k ₁	435		408		505		479		575	
	k ₂	180				222				265	
	g	165				192				214	
	g ₁	118				161				172	

¹⁾ → 803 - SRS / SRM / ECN / EQN / EQI / S20 / T20 / CDD

GST□□-2A VBR

	o		o ₁		p			h		a		
GST04...	100		174		132			80		0		
GST05...	115		214		159			100		1		
GST06...	145		243		198			125		2		
GST07...	180		302		251			160		3		
GST09...	222		370		311			200		4		
GST11...	270		433		385			250		4		
GST14...	328		533		479			315		6		

	d	l	l ₁	l ₂	d ₂	u	t	b ₅	b ₇	c ₅	e ₅	f ₅	i	i ₅	m	n	n ₁	s ₅
GST04...	20	40	5	28	M6	6	22.5	76	105	18	129	112	43	53	25	20	36	9
GST05...	25	50	4	40	M10	8	28	90	125	23	155	139	53	66	33	26	49	11
GST06...	30	60	6	45			33	106	160	28	196	157	64	79	38	35	52	13.5
GST07...	40	80	7	63	M16	12	43	130	200	34	247	196	84	104	49	45	66	18
GST09...	50	100	8	80			14	53.5	165	245	44	298	239	105	127.5	54	48	
GST11...	60	120		15	100	M20	18	64	200	300	54	368	280	125	155	69	65	80
GST14...	80	160	125		22			85	250	380	65	460	340	165	200	85	85	91

d ≤ 50 mm: k6; d > 50 mm: m6

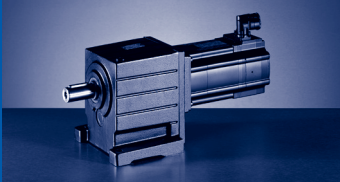

GST [mm]

GST□□-2A (MCA)

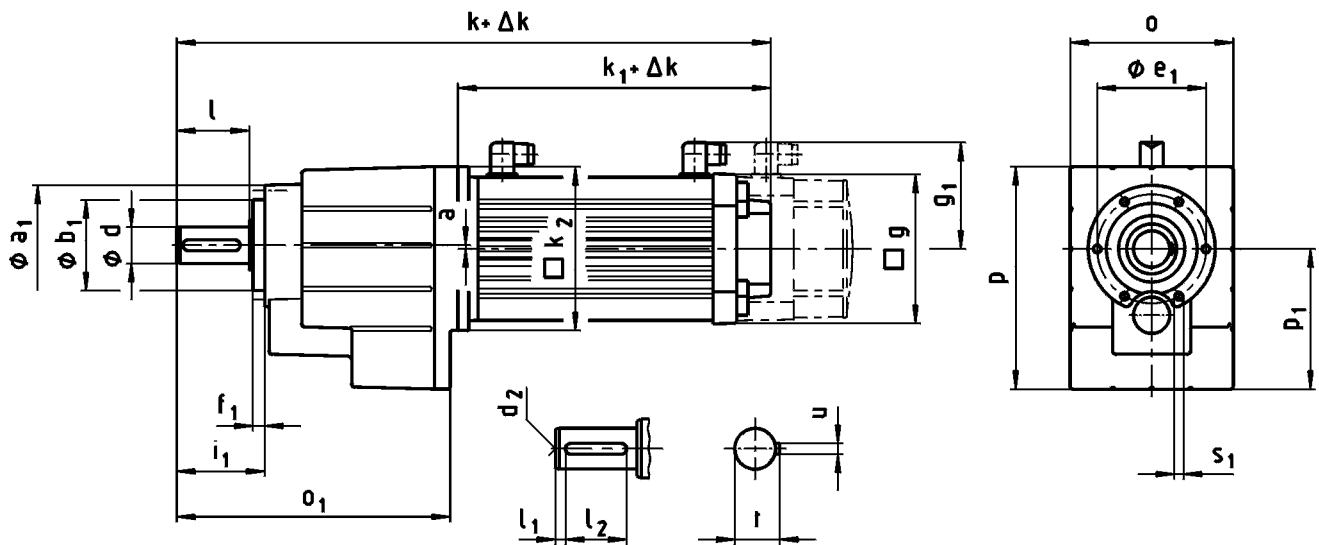

GST□□-2A VCR ... RSO

		10I C40 ...S00	13I C41 ...S00	13I C34 ...F10	14L C20 ...S00	14L C41 ...S00	14L C16 ...F10	14L C35 ...F10	17N C23 ...S00	17N C41 ...S00
GST04...	k	447	455	523						
GST05...	k	477	485	553	535		597			
GST06...	k	503	511	579	561		623		600	
GST07...	k	559	567	635	617		679		656	
GST09...	k				680		742		719	
GST11...	k				737		799		776	
...RSO B0 ¹⁾	Δk					0				
...RSO P□ ¹⁾	Δk	25	35			33			35	
	k_1	258	267	335	307		369		346	
	k_2		145				180			
	g	102	131			142			165	
	g_1	90	102			109			118	

¹⁾ → 803 - SRS / SRM / ECN / EQN / EQI / S20 / T20 / CDD

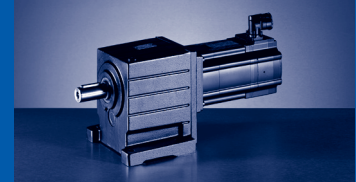

GST□□-2A VCR ... RSO

		17N C17 ...F10	17N C35 ...F10	19S C23 ...S00	19S C42 ...S00	19S C17 ...F10	19S C35 ...F10	21X C25 ...S00	21X C42 ...S00	21X C17 ...F10	21X C35 ...F10
GST06...	k	689									
GST07...	k	745		725		822		803		899	
GST09...	k	808		788		885		866		962	
GST11...	k	865		845		942		923		1019	
GST14...	k			935		1032		1013		1109	
...RSO B0 ¹⁾	Δ k	0									
...RSO P□ ¹⁾	Δ k	35		38				42			
	k ₁	435		408		505		479		575	
	k ₂	180		222				265			
	g	165		192				214			
	g ₁	118		161				172			

¹⁾ → 803 - SRS / SRM / ECN / EQN / EQI / S20 / T20 / CDD

GST□□-2A VCR

	o	o ₁	p		p ₁		a	
GST04...	100	174	129		77		0	
GST05...	115	214	156		98		1	
GST06...	145	243	194		121		2	
GST07...	180	302	245		155		3	
GST09...	222	370	304		194		4	
GST11...	270	433	378		243		4	
GST14...	328	533	470		306		6	

	d	l	l ₁	l ₂	d ₂	u	t	a ₁	b ₁	e ₁	f ₁	i ₁	s ₁
									h7				6x60°
GST04...	20	40	5	28	M6	6	22.5	72	48	61	8	51	M5x10
GST05...	25	50	4	40	M10	8	28	88	58	74	9	62	M6x12
GST06...	30	60	6	45			33	109	70	90	10	74	M8x14
GST07...	40	80	7	63	M16	12	43	140	100	120	13	97	M10x18
GST09...	50	100	8	80			14	53.5	174	120	145	15	120
GST11...	60	120		15	100	M20	18	64	215	150	185	18	143
GST14...	80	160	125		22			85	265	195	230	22	187

d ≤ 50 mm: k6; d > 50 mm: m6

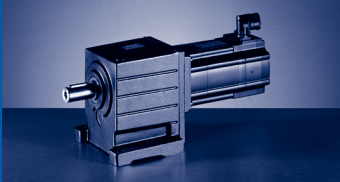

GST [mm]

GST□□-2A (MCA)

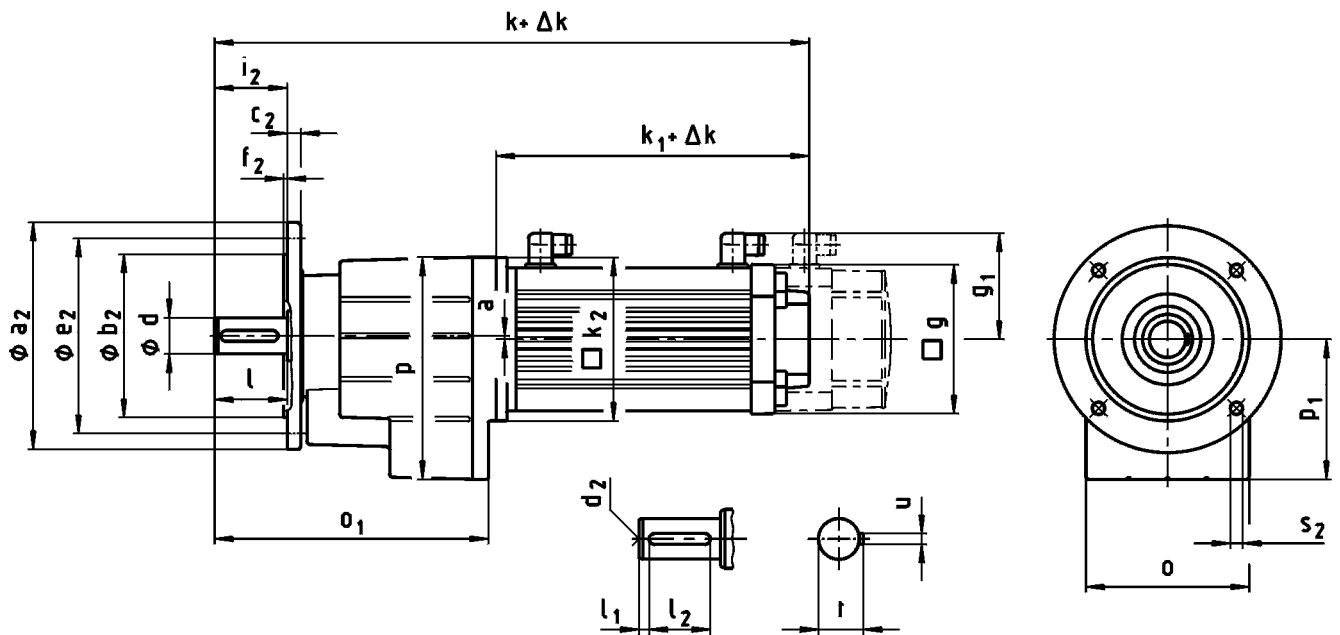

GST□□-2A VCK ... RSO

		10I C40 ...S00	13I C41 ...S00	13I C34 ...F10	14L C20 ...S00	14L C41 ...S00	14L C16 ...F10	14L C35 ...F10	17N C23 ...S00	17N C41 ...S00
GST04...	k	447	455	523						
GST05...	k	477	485	553	535		597			
GST06...	k	503	511	579	561		623		600	
GST07...	k	559	567	635	617		679		656	
GST09...	k				680		742		719	
GST11...	k				737		799		776	
...RSO B0 ¹⁾	Δk	0								
...RSO P□ ¹⁾	Δk	25	35		33			35		
	k_1	258	267	335	307		369		346	
	k_2	145			180					
	g	102	131		142				165	
	g ₁	90	102		109				118	

¹⁾ → 803 - SRS / SRM / ECN / EQN / EQI / S20 / T20 / CDD

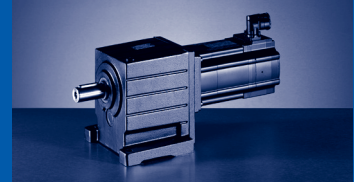

GST□□-2A VCK ... RSO

		17N C17 ...F10	17N C35 ...F10	19S C23 ...S00	19S C42 ...S00	19S C17 ...F10	19S C35 ...F10	21X C25 ...S00	21X C42 ...S00	21X C17 ...F10	21X C35 ...F10
GST06...	k	689									
GST07...	k	745		725		822		803		899	
GST09...	k	808		788		885		866		962	
GST11...	k	865		845		942		923		1019	
GST14...	k			935		1032		1013		1109	
...RSO B0 ¹⁾	Δ k	0									
...RSO P□ ¹⁾	Δ k	35		38				42			
	k ₁	435		408		505		479		575	
	k ₂	180		222				265			
	g	165		192				214			
	g ₁	118		161				172			

1) → 803 - SRS / SRM / ECN / EQN / EQI / S20 / T20 / CDD

GST□□-2A VCK

	o	o ₁	p	p ₁	a	d	l	l ₁	l ₂	d ₂	u	t
GST04...	100	174	129	77	0	20	40	5	28	M6	6	22.5
GST05...	115	214	156	98	1	25	50	4	40	M10	8	28
GST06...	145	243	194	121	2	30	60	6	45			
GST07...	180	302	245	155	3	40	80	7	63	M16	12	43
GST09...	222	370	304	194	4	50	100	8	80			
GST11...	270	433	378	243		60	120		100	M20	18	64
GST14...	328	533	470	306	6	80	160	15	125			

	a ₂	b ₂	c ₂	e ₂	f ₂	i ₂	s ₂		a ₂	b ₂	c ₂	e ₂	f ₂	i ₂	s ₂
		j7					4x90°			j7					4x90°
GST04...	120	80	10	100	3	40	7	GST07...	200	130	14	165	3.5	80	11
	140	95		115			9		250	180	15	215			13.5
	160	110		130	3.5		7		4	100	13.5				
GST05...	120	80	100	3	50	7	GST09...	300		230	18	265	5	120	14
	140	95	115			9		5	120	14					
	160	110	130	3.5		11			GST11...	350	250	20	300		5
GST06...	160	110	12		130	60	9	GST14...		400	300	22	350	5	
	200	130	165	11	400		300		24	350					

d ≤ 50 mm: k6; d > 50 mm: m6

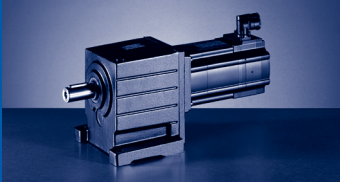

GST [mm]

GST□□-3A (MCA)

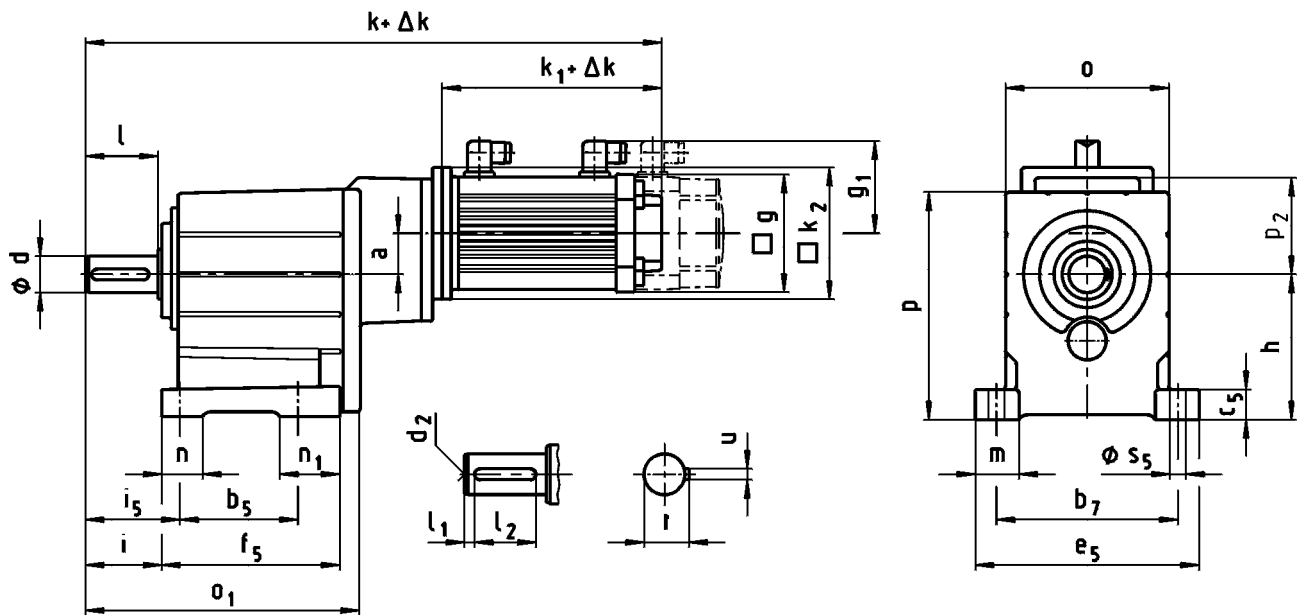

GST□□-3A VBR ... RSO

		10I C40 ...S00	13I C41 ...S00	13I C34 ...F10	14L C20 ...S00	14L C41 ...S00	14L C16 ...F10	14L C35 ...F10	17N C23 ...S00	17N C41 ...S00
GST05...	k	553	562	630						
GST06...	k	596	605	673						
GST07...	k	663	672	740	722		784			
GST09...	k	744	753	821	803		865		842	
GST11...	k	820	829	897	879		941		918	
GST14...	k				1003		1065		1042	
...RSO B0 ¹⁾	Δk				0					
...RSO P□ ¹⁾	Δk	25	35			33			35	
	k_1	258	267	335	307		369		346	
	k_2		145				180			
	g	102	131			142			165	
	g_1	90	102			109			118	

¹⁾ → 803 - SRS / SRM / ECN / EQN / EQI / S20 / T20 / CDD



GST□□-3A VBR ... RSO

		17N C17 ...F10	17N C35 ...F10	19S C23 ...S00	19S C42 ...S00	19S C17 ...F10	19S C35 ...F10	21X C25 ...S00	21X C42 ...S00	21X C17 ...F10	21X C35 ...F10
GST09...	k	931				1083		1065		1161	
GST11...	k	1007		986		1083		1065		1161	
GST14...	k	1131		1110		1207		1189		1285	
...RSO B0 ¹⁾	Δ k	0									
...RSO P□ ¹⁾	Δ k	35		38				42			
	k ₁	435		408		505		479		575	
	k ₂	180				222				265	
	g	165				192				214	
	g ₁	118				161				172	

¹⁾ →  803 - SRS / SRM / ECN / EQN / EQI / S20 / T20 / CDD

GST□□-3A VBR

	o	o ₁	p	p ₂	h	a
GST05...	115	208	159	87	100	35
GST06...	145	240	198		125	34
GST07...	180	302	251	103	160	42
GST09...	222	370	311	129	200	52
GST11...	270	433	385	162	250	66
GST14...	328	533	479	200	315	83

	d	l	l ₁	l ₂	d ₂	u	t	b ₅	b ₇	c ₅	e ₅	f ₅	i	i ₅	m	n	n ₁	s ₅
GST05...	25	50	4	40	M10	8	28	90	125	23	155	139	53	66	33	26	49	11
GST06...	30	60	6	45			33	106	160	28	196	157	64	79	38	35	52	13.5
GST07...	40	80	7	63	M16	12	43	130	200	34	247	196	84	104	49	45	66	18
GST09...	50	100	8	80			14	53.5	165	245	44	298	239	105	127.5	54	48	
GST11...	60	120		100	M20	18	64	200	300	54	368	280	125	155	69	65	80	22
GST14...	80	160	15	125				22	85	250	380	65	460	340	165	200	85	85

d ≤ 50 mm: k6; d > 50 mm: m6

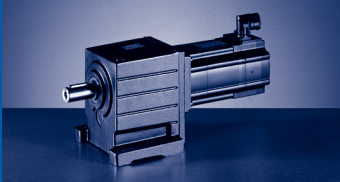

GST [mm]

GST□□-3A (MCA)

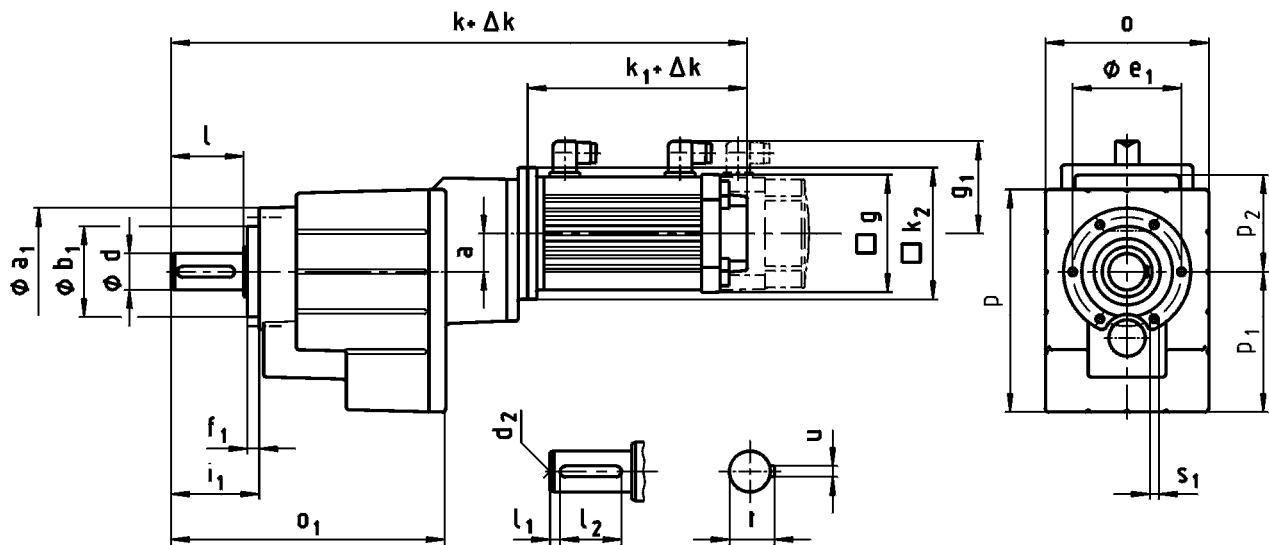

GST□□-3A VCR ... RSO

		10I C40 ...S00	13I C41 ...S00	13I C34 ...F10	14L C20 ...S00	14L C41 ...S00	14L C16 ...F10	14L C35 ...F10	17N C23 ...S00	17N C41 ...S00
GST05...	k	553	562	630						
GST06...	k	596	605	673						
GST07...	k	663	672	740		722		784		
GST09...	k	744	753	821		803		865		842
GST11...	k	820	829	897		879		941		918
GST14...	k					1003		1065		1042
...RSO B0 ¹⁾	Δ k					0				
...RSO P□ ¹⁾	Δ k	25		35		33			35	
	k ₁	258	267	335		307		369		346
	k ₂		145					180		
	g	102		131			142			165
	g ₁	90		102			109			118

¹⁾ → 803 - SRS / SRM / ECN / EQN / EQI / S20 / T20 / CDD

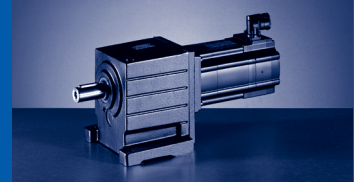

GST□□-3A VCR ... RSO

		17N C17 ...F10	17N C35 ...F10	19S C23 ...S00	19S C42 ...S00	19S C17 ...F10	19S C35 ...F10	21X C25 ...S00	21X C42 ...S00	21X C17 ...F10	21X C35 ...F10
GST09...	k	931									
GST11...	k	1007		986		1083		1065		1161	
GST14...	k	1131		1110		1207		1189		1285	
...RSO B0 ¹⁾	Δ k	0									
...RSO P□ ¹⁾	Δ k	35		38				42			
	k ₁	435		408		505		479		575	
	k ₂	180				222				265	
	g	165				192				214	
	g ₁	118				161				172	

¹⁾ → 803 - SRS / SRM / ECN / EQN / EQI / S20 / T20 / CDD

GST□□-3A VCR

	o	o ₁	p		p ₁		p ₂		a	
GST05...	115	208	156		98		87		35	
GST06...	145	240	194		121				34	
GST07...	180	302	245		155		103		42	
GST09...	222	370	304		194		129		52	
GST11...	270	433	378		243		162		66	
GST14...	328	533	470		306		200		83	

	d	l	l ₁	l ₂	d ₂	u	t	a ₁	b ₁	e ₁	f ₁	i ₁	s ₁
									h7				6x60°
GST05...	25	50	4	40	M10	8	28	88	58	74	9	62	M6x12
GST06...	30	60	6	45			33	109	70	90	10	74	M8x14
GST07...	40	80	7	63	M16	12	43	140	100	120	13	97	M10x18
GST09...	50	100	8	80			53.5	174	120	145	15	120	M12x20
GST11...	60	120		100	M20	18	64	215	150	185	18	143	M16x26
GST14...	80	160	15	125			85	265	195	230	22	187	M20x34

d ≤ 50 mm: k6; d > 50 mm: m6

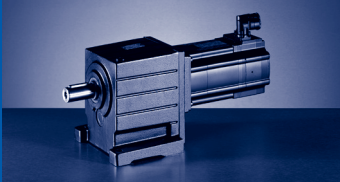

GST [mm]

GST□□-3A (MCA)

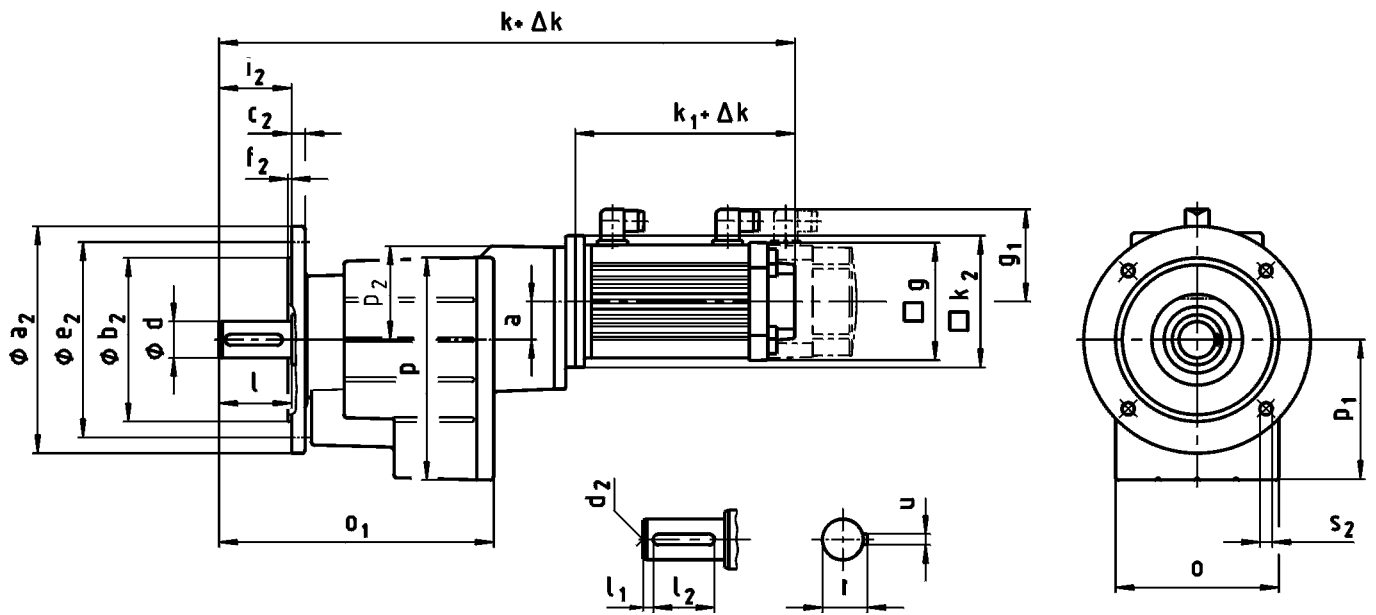

GST□□-3A VCK ... RSO

		10I C40 ...S00	13I C41 ...S00	13I C34 ...F10	14L C20 ...S00	14L C41 ...S00	14L C16 ...F10	14L C35 ...F10	17N C23 ...S00	17N C41 ...S00
GST05...	k	553	562	630						
GST06...	k	596	605	673						
GST07...	k	663	672	740	722		784			
GST09...	k	744	753	821	803		865		842	
GST11...	k	820	829	897	879		941		918	
GST14...	k				1003		1065		1042	
...RSO B0 ¹⁾	Δk				0					
...RSO P□ ¹⁾	Δk	25	35			33			35	
	k_1	258	267	335	307		369		346	
	k_2		145				180			
	g	102	131			142			165	
	g_1	90	102			109			118	

¹⁾ → 803 - SRS / SRM / ECN / EQN / EQI / S20 / T20 / CDD

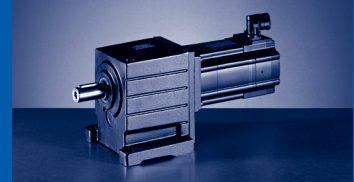

GST□□-3A VCK ... RSO

		17N C17 ...F10	17N C35 ...F10	19S C23 ...S00	19S C42 ...S00	19S C17 ...F10	19S C35 ...F10	21X C25 ...S00	21X C42 ...S00	21X C17 ...F10	21X C35 ...F10
GST09...	k	931				1083		1065		1161	
GST11...	k	1007		986		1083		1065		1161	
GST14...	k	1131		1110		1207		1189		1285	
...RSO B0 ¹⁾	Δ k	0									
...RSO P□ ¹⁾	Δ k	35		38				42			
	k ₁	435		408		505		479		575	
	k ₂	180				222				265	
	g	165				192				214	
	g ₁	118				161				172	

¹⁾ →  803 - SRS / SRM / ECN / EQN / EQI / S20 / T20 / CDD

GST□□-3A VCK

	o	o ₁	p	p ₁	p ₂	a
GST05...	115	208	156	98	87	35
GST06...	145	240	194	121		34
GST07...	180	302	245	155	103	42
GST09...	222	370	304	194	129	52
GST11...	270	433	378	243	162	66
GST14...	328	533	470	306	200	83

	d	l	l ₁	l ₂	d ₂	u	t	a ₂	b ₂	c ₂	e ₂	f ₂	i ₂	s ₂
GST05...	25	50	4	40	M10	8	28	120	80	10	100	3	50	7
								140	95		115			9
								160	110		130			11
								200	130		165			11
GST06...	30	60	6	45	M16	12	33	160	110	12	130	3.5	60	9
								200	130		165			11
GST07...	40	80	7	63	M16	14	53.5	250	180	15	215	4	80	13.5
GST09...	50	100	8	80				M20	18		64			
GST11...	60	120		100	M20	18	64			350		250	20	22
			GST14...					80	160		15			

d ≤ 50 mm: k6; d > 50 mm: m6

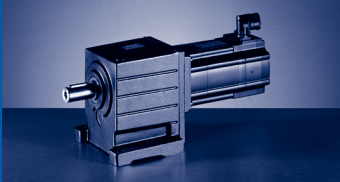

GST & [mm]

GST□□-2 / 3

GST□□-2A/S VAR
 GST□□-3A/S VAR

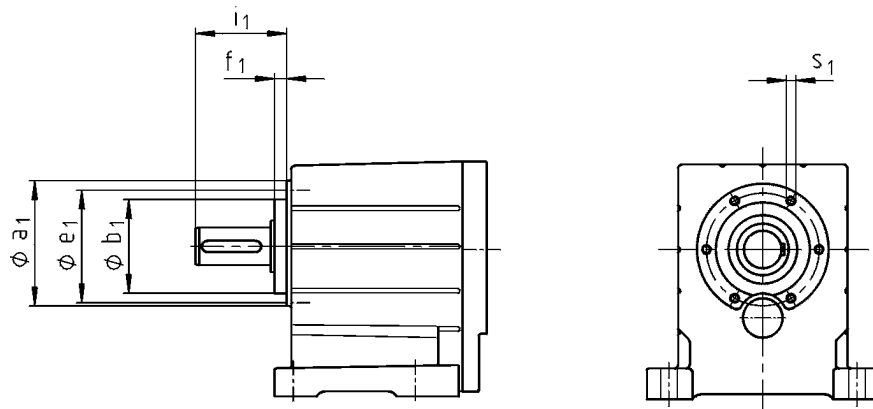

	a ₁	b ₁	e ₁	f ₁	i ₁	s ₁
		h7				6x60°
GST04...	72	48	61	8	51	M5x10
GST05...	88	58	74	9	62	M6x12
GST06...	109	70	90	10	74	M8x14
GST07...	140	100	120	13	97	M10x18
GST09...	174	120	145	15	120	M12x20
GST11...	215	150	185	18	143	M16x26
GST14...	265	195	230	22	187	M20x34

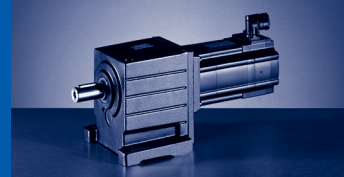

GST□□-2A/S VAL
GST□□-3A/S VAL

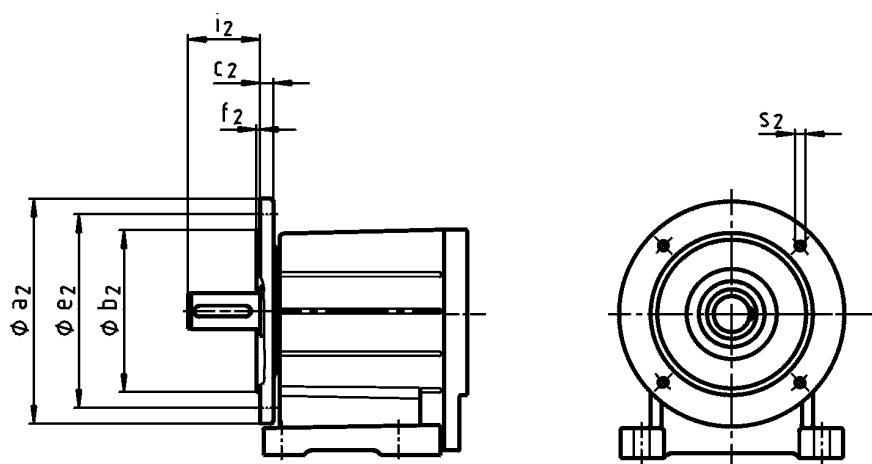

	a_2	b_2	c_2	e_2	f_2	i_2	s_2
		j7					4x90°
GST04...	120	80	10	100	3	40	M6
	140	95		115			M8
GST05...	120	80		100	3.5	50	M6
	140	95		115			M8
	160	110	130	60			
GST06...	200	130	12	165	80	M10	
GST07...	250	180	14	215	4	100	M12
			15				
GST09...	300	230	16	265	120		
GST11...	350	250	18	300	5	160	M16
GST14...			20				
			22				
	400	300	24	350			

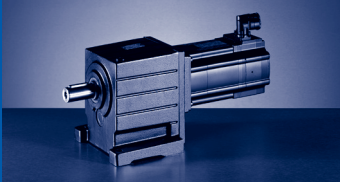

GST & [mm]

GST□□-2 / 3

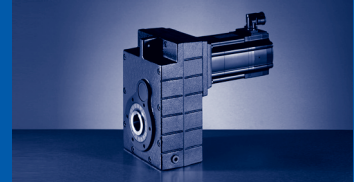

Permissible radial force

$$Fr_{zul} = \min(f_w \times f_{\alpha} \times Fr_{Tab}; f_w \times Fr_{max})$$

At Fr and $Fa \neq 0$ please contact your Lenze sales office.

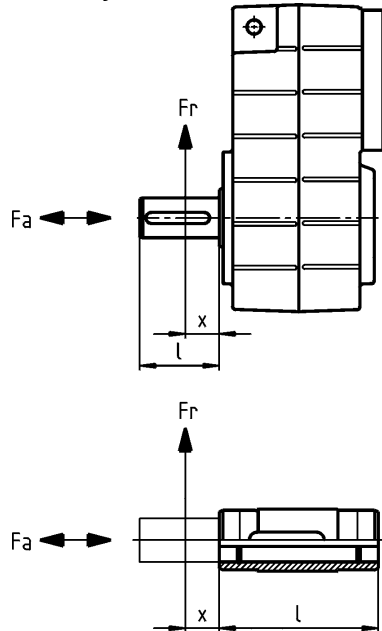

Permissible axial force

$$Fa_{zul} = Fa_{Tab} \text{ at } Fr = 0$$

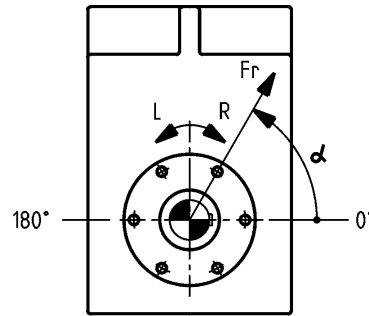

Effective direction factor f_{α} at output shaft

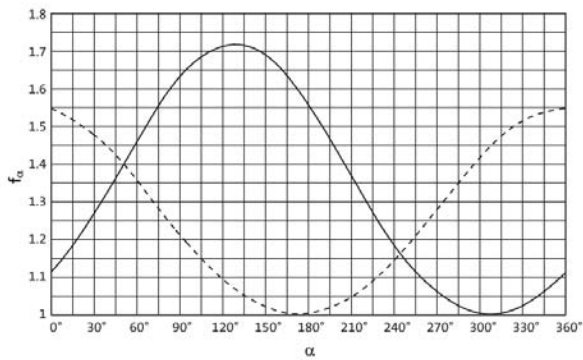

- Direction of rotation R
- - - Direction of rotation L

Additional load factor f_w at output shaft

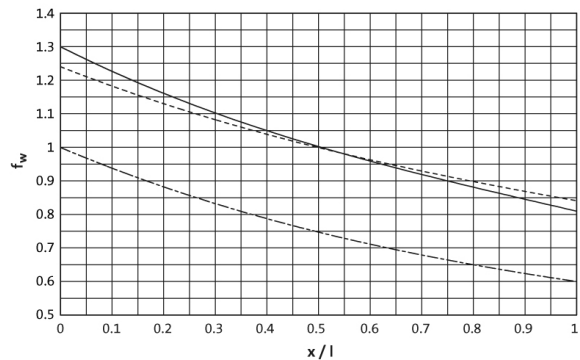

- Solid shaft (V□R)
- - - Solid shaft with flange (V□K)
- · - Hollow shaft (H□□)

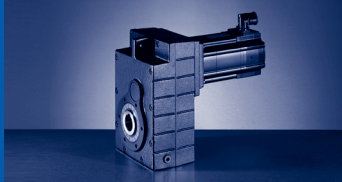

GFL [N]

Solid shaft without flange (V□R)														
Application of force Fr: centre of shaft journal (x = l/2)														
Fa _{Tab} only valid for Fr = 0														
	GFL04-2		GFL05-2/3		GFL06-2/3		GFL07-2/3		GFL09-2/3 ¹⁾		GFL11-2/3 ¹⁾		GFL14-2/3	
n ₂ [min ⁻¹]	Fr _{Tab} [N]	Fa _{Tab} [N]	Fr _{Tab} [N]	Fa _{Tab} [N]	Fr _{Tab} [N]	Fa _{Tab} [N]	Fr _{Tab} [N]	Fa _{Tab} [N]	Fr _{Tab} [N]	Fa _{Tab} [N]	Fr _{Tab} [N]	Fa _{Tab} [N]	Fr _{Tab} [N]	Fa _{Tab} [N]
1000	1650	1300	1400	1600	1850	2400	1650	2000	-	-	-	-	-	-
630	2100	1700	1900	2200	2500	3200	2600	2700	-	-	-	-	-	-
400	2300	2200	2400	2800	3200	4000	3200	3400	3800	3100	5500	4700	47000	25000
250	2700	2600	2700	3600	3600	5200	3600	4700	4400	4200	6300	6000	54000	27000
160	3200	3200	3200	4200	3900	6000	3900	6000	5500	5800	7300	7500	62000	29000
100	3600	4200	4000	5900	5100	8500	5100	8500	8000	10000	11200	14000	65000	32000
63	3600	5300	4800	6600	6500	10000	6500	12000	10000	13500	14500	19000	65000	35000
40	3600	5500	5800	6600	8400	10000	8400	14000	12000	17000	17400	25000	65000	35000
25	3600	5500	6200	6600	9000	10000	9000	14000	18000	21000	20500	27000	65000	35000
≤ 16	3600	5500	6200	6600	9000	10000	9000	14000	18000	21000	23000	27000	65000	35000
Fr _{max}	3600	-	7000	-	11000	-	11000	-	22000	-	28000	-	65000	-

¹⁾ Reinforced output shaft bearings are available on request for V□R versions.

Solid shaft with flange (V□K)														
Application of force Fr: centre of shaft journal (x = l/2)														
Fa _{Tab} only valid for Fr = 0														
	GFL04-2		GFL05-2/3		GFL06-2/3		GFL07-2/3		GFL09-2/3		GFL11-2/3		GFL14-2/3	
n ₂ [min ⁻¹]	Fr _{Tab} [N]	Fa _{Tab} [N]	Fr _{Tab} [N]	Fa _{Tab} [N]	Fr _{Tab} [N]	Fa _{Tab} [N]	Fr _{Tab} [N]	Fa _{Tab} [N]	Fr _{Tab} [N]	Fa _{Tab} [N]	Fr _{Tab} [N]	Fa _{Tab} [N]	Fr _{Tab} [N]	Fa _{Tab} [N]
1000	2300	1300	2900	1800	4000	2500	4000	3600	-	-	-	-	-	-
630	2800	1700	3700	2400	5000	3400	5200	4800	-	-	-	-	-	-
400	3200	2200	4300	3100	6100	4300	6400	6100	7800	6100	12500	6800	18000	6000
250	3700	2600	5100	3900	7000	5500	7400	6500	9000	6500	14500	8500	20000	8000
160	4400	3200	5900	4800	7800	6500	8900	7000	10500	7000	17000	10500	23000	10000
100	4600	4200	6800	6400	9600	8500	10500	9500	14000	9500	21500	17000	27500	13000
63	4600	4400	7000	6600	10000	10000	12000	11500	15000	11500	26000	22000	32000	19000
40	4600	4400	7000	6600	10000	10000	13000	11500	15000	11500	30000	27000	38000	26000
25	4600	4400	7000	6600	10000	10000	14000	11500	15000	11500	30000	27000	43000	35000
≤ 16	4600	4400	7000	6600	10000	10000	14000	11500	15000	11500	30000	27000	43000	35000
Fr _{max}	4600	-	7400	-	11000	-	16000	-	16000	-	32000	-	46000	-

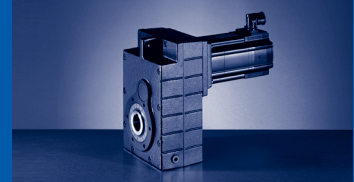

Hollow shaft (H□□)														
Application of force F_r : on hollow shaft end face ($x = 0$)														
$F_{a_{Tab}}$ only valid for $F_r = 0$														
	GFL04-2		GFL05-2/3		GFL06-2/3		GFL07-2/3		GFL09-2/3		GFL11-2/3		GFL14-2/3	
n_2 [min ⁻¹]	$F_{r_{Tab}}$ [N]	$F_{a_{Tab}}$ [N]	$F_{r_{Tab}}$ [N]	$F_{a_{Tab}}$ [N]	$F_{r_{Tab}}$ [N]	$F_{a_{Tab}}$ [N]	$F_{r_{Tab}}$ [N]	$F_{a_{Tab}}$ [N]	$F_{r_{Tab}}$ [N]	$F_{a_{Tab}}$ [N]	$F_{r_{Tab}}$ [N]	$F_{a_{Tab}}$ [N]	$F_{r_{Tab}}$ [N]	$F_{a_{Tab}}$ [N]
1000	2100	1300	1800	1600	2400	2400	2200	2000	-	-	-	-	-	-
630	2700	1700	2400	2200	3300	3200	3400	2700	-	-	-	-	-	-
400	2800	2200	3000	2800	4300	4000	4500	3400	5000	3100	7300	4700	8000	4000
250	3200	2600	3400	3600	4700	5200	5100	4700	6000	4200	8700	6000	9000	5000
160	3800	3200	4100	4200	5000	6000	6400	6000	7200	5800	10000	7500	9500	6200
100	4600	4200	5000	5900	6600	8500	7900	8500	10500	10000	14200	14000	11500	7500
63	5500	5300	6000	6600	8500	10000	9300	12000	13000	13500	19000	19000	14000	11000
40	6300	5500	7100	6600	10800	10000	11500	14000	15000	17000	23000	25000	18000	17500
25	7000	5500	8000	6600	12000	10000	15000	14000	22000	21000	27000	27000	30000	31000
≤ 16	7000	5500	8000	6600	12000	10000	16000	14000	24000	21000	30000	27000	45000	35000
$F_{r_{max}}$	7000	-	10000	-	15000	-	20000	-	30000	-	38000	-	56000	-

- ▶ Neither radial nor axial forces are permissible for the hollow shaft with shrink disc (S□□).

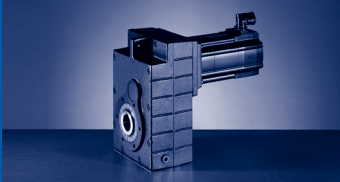

Output backlash in angular minutes

GFL04...14-2

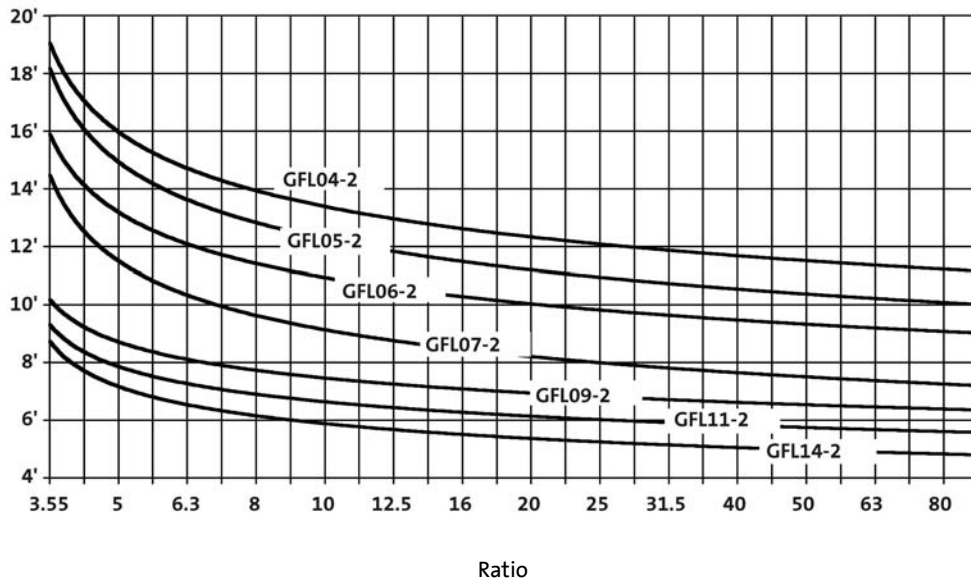

GFL05...14-3

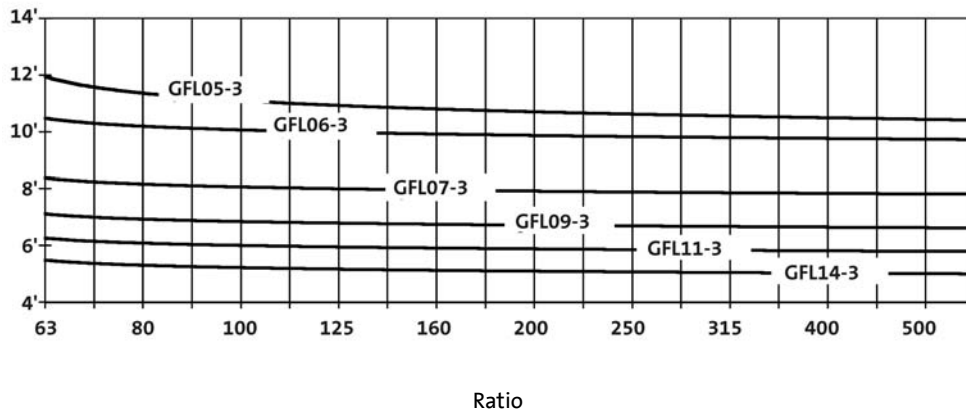

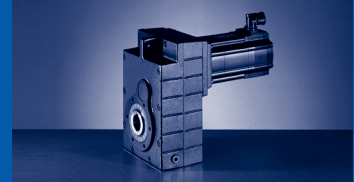

Position of ventilation, sealing elements and oil control

GFL05...14-2

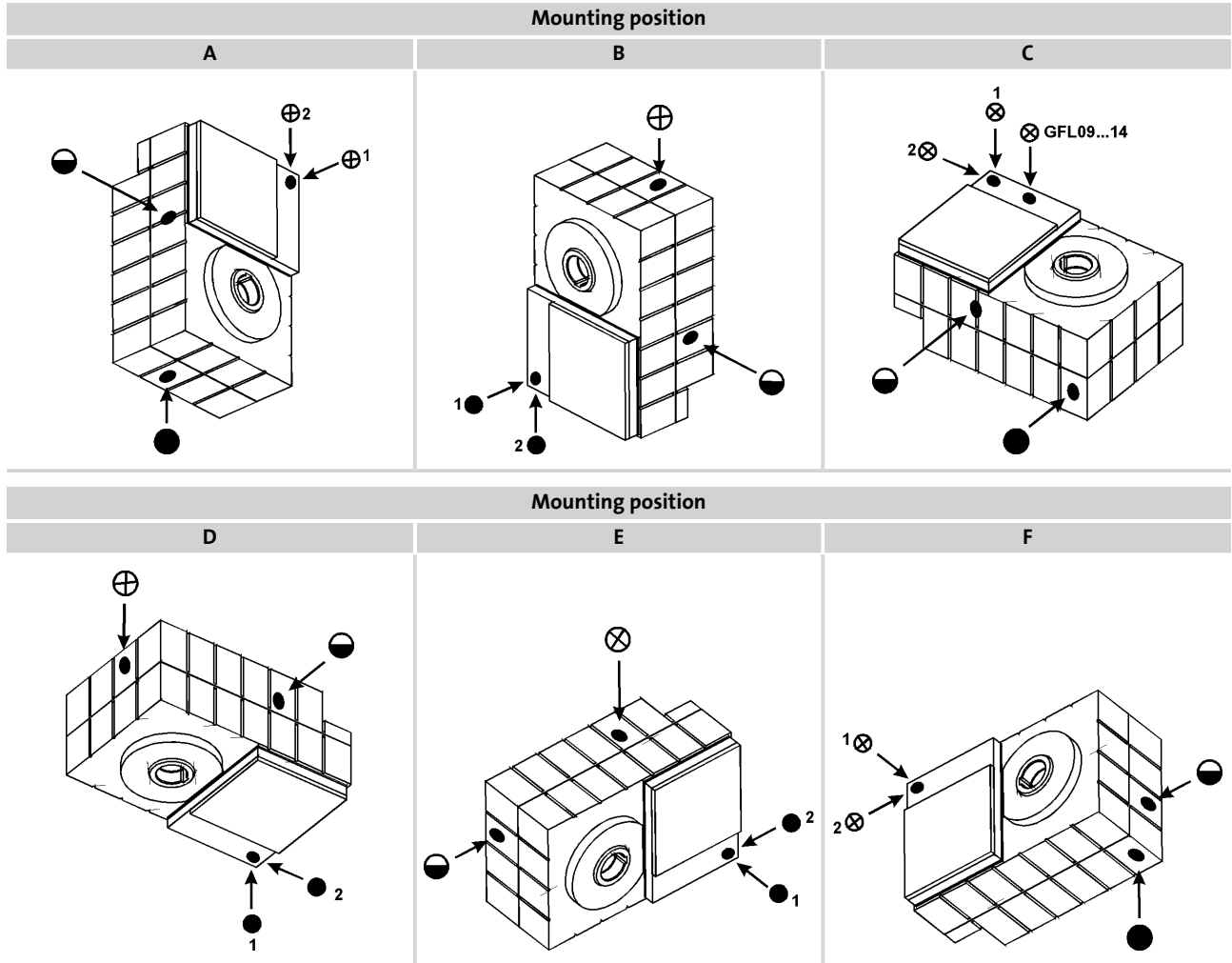

- ⊗ Ventilation/oil filler plug
- Oil drain plug
- ◐ Oil control plug
- * On both sides
- ** Opposite

Pos.1 standard
 Pos.2 only on GFL05-2A □□□ 14LC□□

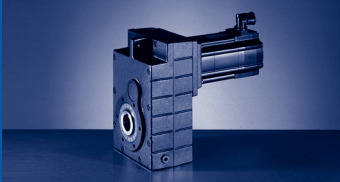

Position of ventilation, sealing elements and oil control

GFL05...14-3

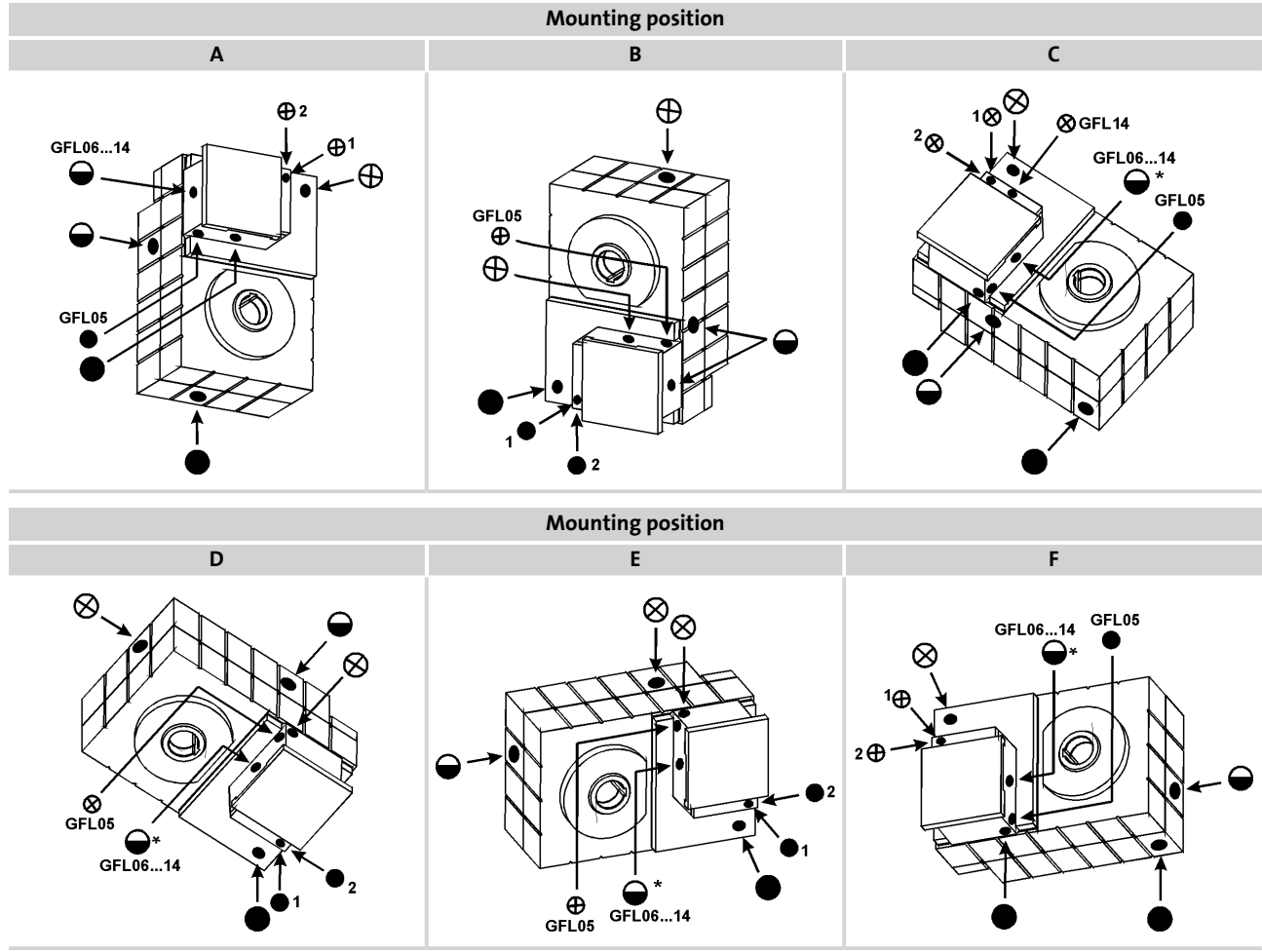

- ⊗ Ventilation/oil filler plug
- Oil drain plug
- ◐ Oil control plug
- * On both sides
- ** Opposite

Pos.1 standard
 Pos.2 only on GFL07-3A □□□ 14LC□□

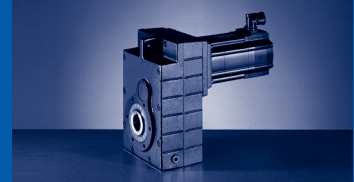

Compensation reservoir for mounting position C

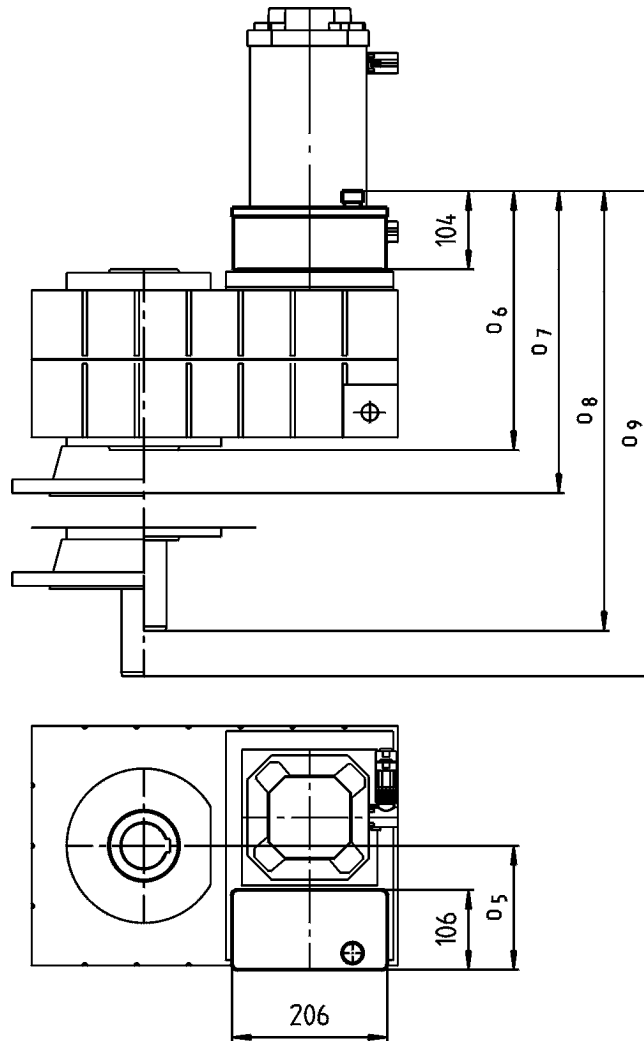

GFL□□-2A...		14LC□□ ¹⁾	17NC□□ ¹⁾	19SC□□ ¹⁾	21XC□□ ¹⁾	GFL□□-2S...		12□C□□	14□C□□	19□C□□	
GFL09...	o ₅	165		187	204	GFL09...	o ₅	165		204	
	o ₆		344				o ₆		344		
	o ₇		405				o ₇		405		
	o ₈		464				o ₈		464		
	o ₉		525				o ₉		525		
GFL11...	o ₅	154		176	200	GFL11...	o ₅	154		200	
	o ₆	387		391			o ₆	387		391	
	o ₇	448		452			o ₇	448		452	
	o ₈	547		551			o ₈	547		551	
	o ₉	608		612			o ₉	608		612	
GFL14...	o ₅			181	211	GFL14...	o ₅			211	
	o ₆			446			o ₆			446	
	o ₇			507			o ₇			507	
	o ₈			646			o ₈			646	
	o ₉			707			o ₉			707	

¹⁾ Connector/terminal box position 3 is not permitted.

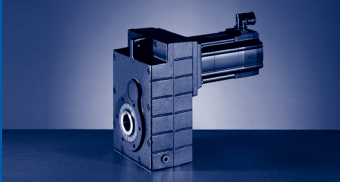

GFL [kg]

GFL□□-2S HCR/HDR...RSO B0

	06C C41	06F C41	06I C41	09D C41	09F C38	09H C41	09L C41	12D C20	12D C41	12H C15	12H C30	12H C35	12L C20	12L C41
GFL04...	9		10	12	13	14	16							
GFL05...	21		22	24		25	27			30				33
GFL06...	35	36	37	38	39	40	42	41		44				47
GFL07...				64	65	66	68	67		70				73
GFL09...								115		118				121

	14D C15	14D C36	14H C15	14H C32	14L C15	14L C32	14P C14	14P C32	19F C14	19F C30	19J C14	19J C30	19P C14	19P C30
GFL06...	46		51		56		60							
GFL07...	73		77		82		87		89		96		106	
GFL09...	120		125		129		134		136		143		153	
GFL11...	206		210		215		220		221		228		238	
GFL14...								363		370		380		

GFL□□-3S HCR/HDR...RSO B0

	06C C41	06F C41	06I C41	09D C41	09F C38	09H C41	09L C41	12D C20	12D C41	12H C15	12H C30	12H C35	12L C20	12L C41
GFL05...	23		24	26	27	28	30							
GFL06...	40		41	43	44	45	47							
GFL07...	69		70	71	72	73	75		78				81	
GFL09...	121		122	123	124	125	127	126		129				133
GFL11...				217	218	219	221	220		223				226
GFL14...								377		380				383

	14D C15	14D C36	14H C15	14H C32	14L C15	14L C32	14P C14	14P C32	19F C14	19F C30	19J C14	19J C30	19P C14	19P C30
GFL07...														
GFL09...	131		136		141		146							
GFL11...	225		230		235		239		242		249		259	
GFL14...	382		387		392		397		399		406		416	

Note additional weights.

Weights in [kg] with oil capacity for mounting position A, all given as approximate values

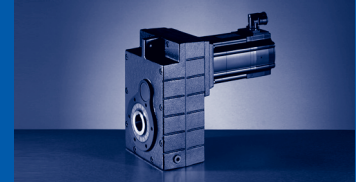

GFL□□-2A HCR/HDR...RSO B0

	10I C40 ...S00	13I C41 ...S00	13I C34 ...F10	14L C20 ...S00	14L C41 ...S00	14L C16 ...F10	14L C35 ...F10	17N C23 ...S00	17N C41 ...S00
GFL04...	13	17	19						
GFL05...	26	30	32		36		38		
GFL06...	40	44	46		50		52		58
GFL07...	66	70	72		76		78		84
GFL09...					122		124		130
GFL11...					208		209		215
GFL14...									

	17N C17 ...F10	17N C35 ...F10	19S C23 ...S00	19S C42 ...S00	19S C17 ...F10	19S C35 ...F10	21X C25 ...S00	21X C42 ...S00	21X C17 ...F10	21X C35 ...F10
GFL06...	61									
GFL07...	86		107		110		124		127	
GFL09...	133		153		156		171		174	
GFL11...	218		238		241		254		258	
GFL14...			380		384		395		398	

GFL□□-3A HCR/HDR...RSO B0

	10I C40 ...S00	13I C41 ...S00	13I C34 ...F10	14L C20 ...S00	14L C41 ...S00	14L C16 ...F10	14L C35 ...F10	17N C23 ...S00	17N C41 ...S00
GFL05...	27	31	33						
GFL06...	44	48	50						
GFL07...	74	78	80		84		86		
GFL09...	125	129	131		135		137		143
GFL11...	219	223	224		228		230		236
GFL14...					385		387		393

	17N C17 ...F10	17N C35 ...F10	19S C23 ...S00	19S C42 ...S00	19S C17 ...F10	19S C35 ...F10	21X C25 ...S00	21X C42 ...S00	21X C17 ...F10	21X C35 ...F10
GFL09...	146									
GFL11...	239		260		263		277		280	
GFL14...	395		415		419		433		437	

Note additional weights.

Weights in [kg] with oil capacity for mounting position A, all given as approximate values

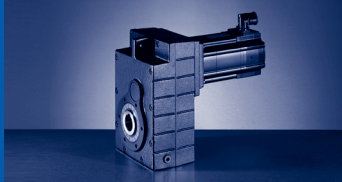

GFL [kg]

Additional weights MCS servo motors

	06C C41	06F C41	06I C41	09D C41	09F C38	09H C41	09L C41	12D C20	12D C41	12H C15	12H C30	12H C35	12L C20	12L C41
...P1	0.3			0.8				0.9						
...P2				0.5				1.2						
...SCS/SCM/SRM/SRS ...ECN/EQN	0.4			0.2				0.3						

	14D C15	14D C36	14H C15	14H C32	14L C15	14L C32	14P C14	14P C32	19F C14	19F C30	19J C14	19J C30	19P C14	19P C30
...P1	1.9								1.5					
...P2	3.1										4.3			
...SCS/SCM/SRM/SRS ...ECN/EQN							0.3							

Additional weights MCA servo motors

	10I C40 ...S00	13I C41 ...S00	13I C34 ...F10	14L C20 ...S00	14L C41 ...S00	14L C16 ...F10	14L C35 ...F10	17N C23 ...S00	17N C41 ...S00
...P1/P5								2.4	
...P2/P6	0.8	1.4				1.5			
...CDD ...ECN/EQN/EQI ...SCS/SCM/SRM/SRS/S20 ...T20	0.3	0.5				0.6		0.7	

	17N C17 ...F10	17N C35 ...F10	19S C23 ...S00	19S C42 ...S00	19S C17 ...F10	19S C35 ...F10	21X C25 ...S00	21X C42 ...S00	21X C17 ...F10	21X C35 ...F10
...P1/P5	2.4		4.8				5			
...P2/P6										
...CDD ...ECN/EQN/EQI ...SCS/SCM/SRM/SRS/S20 ...T20	0.7		1				1.1			

Additional weights gearbox

	Solid shaft	2nd output shaft end	Hollow shaft with shrink disc	Flange	Foot
	V□□	V□□	S□□	□□K	□A□/□B□
GFL04...	0.6	0.2	0.6	2.5	1
GFL05...	1	0.3	0.8	4	1.5
GFL06...	2.5	0.8	1	7	2.5
GFL07...	5	1.5	1.5	11	4
GFL09...	8	2.7	3	16	7
GFL11...	16	6.3	5	24	14
GFL14...	33	12	11	33	23

Weights in [kg]

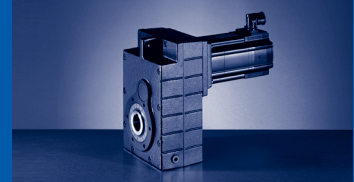

► $i_g = z_g / z_t$

	i	z_g	z_t
GFL04-2	3.659	2415	660
	5.018	2760	550
	5.833	2625	450
	6.422	2967	462
	7.025	3864	550
	8.379	2765	330
	9.333	2800	300
	10.238	3225	315
	11.491	3160	275
	12.8	3200	250
	14.706	3397	231
	16.087	4424	275
	17.92	4480	250
	20.519	4740	231
	22.857	4800	210
	25.136	4977	198
	28	5040	180
	31.6	5214	165
	35.2	5280	150
	40.697	5372	132
	45.333	5440	120
	51.579	6241	121
	57.455	6320	110
	64.636	6399	99
72	6480	90	
85.156	6557	77	
94.857	6640	70	
GFL05-2	3.333	2100	630
	4.571	2400	525
	5.133	2310	450
	5.667	2380	420
	6.4	3360	525
	7.04	2640	375
	7.771	2720	350
	9.01	2838	315
	9.946	2924	294
	11.36	2840	250
	12.8	2880	225
	14.538	3053	210
	15.904	3976	250
	17.92	4032	225
	20.286	4260	210
	22.857	4320	189
	24.85	4473	180
	28	4536	162

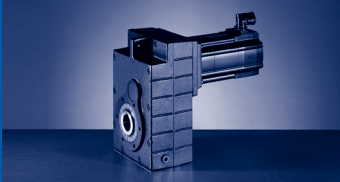

GFL [i]

► $i_g = z_g / z_t$

	i	z_g	z_t
GFL05-2	32.344	5822	180
	36.444	5904	162
	40.233	4828	120
	45.333	4896	108
	52.067	6248	120
	58.667	6336	108
	63.19	6319	100
	71.2	6408	90
	80.763	6461	80
	91	6552	72
GFL05-3	61.653	258944	4200
	78.639	277440	3528
	90.123	270368	3000
	101.547	274176	2700
	114.952	289680	2520
	129.524	293760	2268
	140.817	304164	2160
	158.667	308448	1944
	177.027	318648	1800
	199.467	323136	1620
	227.989	328304	1440
	256.889	332928	1296
	288.948	381412	1320
	325.576	386784	1188
	362.1	391068	1080
	408	396576	972
	477.052	400724	840
	537.524	406368	756
	GFL06-2	3.675	2205
5.211		2345	450
5.75		2415	420
6.45		2709	
7.147		2680	375
8.4		2520	300
9.463		2555	270
10.092		2967	294
11.52		2880	250
12.978		2920	225
14.743		3096	210
16.128		4032	250
18.169		4088	225
20.571		4320	210
23.175		4380	189
25.2		4536	180
28.389		4599	162

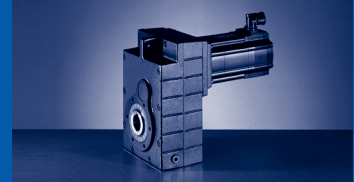

► $i_g = z_g / z_t$

	i	z_g	z_t
GFL06-2	32.8	5904	180
	36.951	5986	162
	40.8	4896	120
	45.963	4964	108
	52.8	6336	120
	59.481	6424	108
	64.08	6408	100
	72.189	6497	90
	81	6480	80
	91.25	6570	72
GFL06-3	66.213	262800	3969
	72	272160	3780
	81.111	275940	3402
	88.2	285768	3240
	99.361	289737	2916
	116.571	293760	2520
	131.323	297840	2268
	144.32	389664	2700
	162.583	395076	2430
	179.52	323136	1800
	202.237	327624	1620
	231.2	332928	1440
	260.457	337552	1296
	293.018	386784	1320
	299.2	430848	1440
	367.2	396576	1080
	413.667	402084	972
	475.2	513216	1080
	535.333	520344	972
	576.72	519048	900
649.7	526257	810	
759.806	531864	700	
855.954	539251	630	
GFL07-2	3.35	2040	609
	4.643	2340	504
	5.159	2244	435
	5.695	2312	406
	6.4	3360	525
	7.15	2574	360
	8.324	2414	290
	9.379	2448	261
	9.714	2856	294
	11.538	2769	240
	13	2808	216
	14.2	2982	210

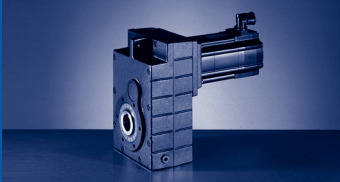

GFL [i]

► $i_g = z_g / z_t$

	i	z_g	z_t
GFL07-2	15.904	3976	250
	17.92	4032	225
	20.286	4260	210
	22.857	4320	189
	24.85	4473	180
	28	4536	162
	32.344	5822	180
	36.444	5904	162
	39.642	4757	120
	44.667	4824	108
	52.067	6248	120
	58.667	6336	108
	63.19	6319	100
	71.2	6408	90
	79.875	6390	80
	90	6480	72
GFL07-3	65.306	259200	3969
	72.452	326032	4500
	81.636	330624	4050
	92.413	349320	3780
	104.127	354240	3402
	113.206	366786	3240
	127.556	371952	2916
	147.347	477404	3240
	166.025	484128	2916
	183.285	395896	2160
	206.519	401472	1944
	224.636	323476	1440
	253.111	328032	1296
	290.706	418616	1440
	327.556	424512	1296
	352.811	423373	1200
	397.533	429336	1080
	430.222	557568	1296
	522.133	563904	1080
	562.391	562391	1000
633.68	570312	900	
718.786	575029	800	
809.9	583128	720	
GFL09-2	6.864	2574	375
	7.466	2613	350
	9.01	2838	315
	9.799	2881	294
	11.167	3752	336
	12.307	2769	225

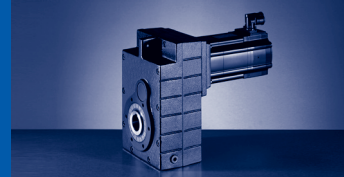

► $i_g = z_g / z_t$

	i	z_g	z_t
GFL09-2	14.333	3010	210
	16.333	3920	240
	18.407	3976	216
	19.667	4130	210
	22.164	4189	189
	24.111	4340	180
	27.173	4402	162
	32.667	5880	180
	36.815	5964	162
	39.667	4760	120
	44.704	4828	108
	51.333	6160	120
	57.852	6248	108
	62.3	6230	100
	70.211	6319	90
	78.75	6300	80
	88.75	6390	72
	GFL09-3	63.326	251340
73.173		329280	4500
82.465		333984	4050
93.333		352800	3780
105.185		357840	3402
114.333		370440	3240
128.852		375732	2916
148.815		482160	3240
167.712		489048	2916
185.111		399840	2160
208.617		405552	1944
224.778		323680	1440
253.321		328304	1296
290.889		418880	1440
327.827		424864	1296
353.033		423640	1200
397.863		429692	1080
424.247		549824	1296
514.881		556072	1080
554.47		554470	1000
624.879	562391	900	
700.875	560700	800	
789.875	568710	720	
GFL11-2	6.864	2574	375
	7.466	2613	350
	9.01	2838	315
	9.799	2881	294
	10.72	3752	350

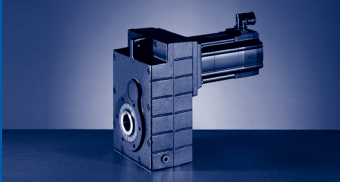

GFL [i]

► $i_g = z_g / z_t$

	i	z_g	z_t	
GFL11-2	12.48	2808	225	
	14.538	3053	210	
	15.904	3976	250	
	17.92	4032	225	
	20.286	4260	210	
	22.857	4320	189	
	24.85	4473	180	
	28	4536	162	
	32.739	5893	180	
	36.889	5976	162	
	40.233	4828	120	
	45.333	4896	108	
	52.067	6248	120	
	58.667	6336	108	
	63.19	6319	100	
	71.2	6408	90	
	79.875	6390	80	
	90	6480	72	
	GFL11-3	65.306	259200	3969
		73.335	330008	4500
82.631		334656	4050	
93.54		353580	3780	
105.397		358560	3402	
114.586		371259	3240	
129.111		376488	2916	
149.144		483226	3240	
168.049		490032	2916	
182.792		394831	2160	
205.963		400392	1944	
224.636		323476	1440	
253.111		328032	1296	
267.259		519552	1944	
327.556		424512	1296	
358.077		429692	1200	
403.467		435744	1080	
430.222		557568	1296	
522.133		563904	1080	
562.391		562391	1000	
633.68	570312	900		
710.888	568710	800		
801	576720	720		
GFL14-2	7.15	2574	360	
	7.777	2613	336	
	8.8	2772	315	
	9.571	2814	294	

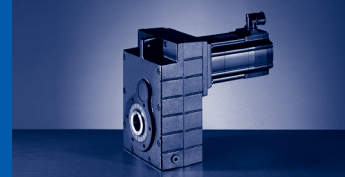

► $i_g = z_g / z_t$

	i	z_g	z_t
GFL14-2	11.538	2769	240
	13	2808	216
	14.2	2982	210
	15.62	3905	250
	17.6	3960	225
	19.948	4189	210
	22.476	4248	189
	24.456	4402	180
	27.556	4464	162
	32.344	5822	180
	36.444	5904	162
	39.642	4757	120
	44.667	4824	108
	52.067	6248	120
	58.667	6336	108
	63.19	6319	100
	71.2	6408	90
	79.875	6390	80
	90	6480	72
	GFL14-3	64.296	249984
68.708		259718	3780
77.418		263376	3402
85.037		330624	3888
104.889		356832	3402
114.126		369768	3240
128.593		374976	2916
136.889		354816	2592
156.148		303552	1944
170.074		495936	2916
202.074		392832	1944
224.636		323476	1440
253.111		328032	1296
273.778		532224	1944
332.444		430848	1296
352.811		423373	1200
397.533		429336	1080
430.222		557568	1296
522.133		563904	1080
562.391		562391	1000
633.68	570312	900	
710.888	568710	800	
801	576720	720	

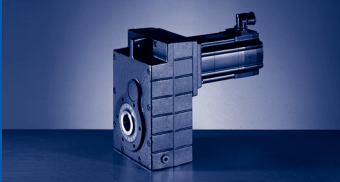

GFL [Nm]

GFL□□-□S (MCS)

$M_{2GN} \leq 187 \text{ Nm}$

GFL04-2S				06CC41	06FC41	06IC41	09DC41	09FC38	09HC41	09LC41
				...S00	...S00	...S00	...S00	...S00	...S00	...S00
i	M_{2GN}	J_G	M_1	0.6	1.2	1.5	2.3	3.1	3.8	4.5
			n_1	4050	4050	4050	4050	3750	4050	4050
			I_{M230}	2.6	2.9	3.2	4.6	5	6.8	8.4
			I_{M400}	1.3	1.5	1.6	2.3	2.5	3.4	4.2
			P_N	0.25	0.51	0.64	1	1.2	1.6	1.9
			J_M	0.17	0.25	0.33	1.13	1.53	1.93	2.83
3.659	100	1.51	M_2						13	15
			c						5.4	4.5
			n_2 Eck						1107	1107
			n_2 th						998	968
5.018	111	0.86	M_2					14	18	21
			c					5.4	4.3	3.7
			n_2 Eck					747	807	807
			n_2 th					747	775	754
5.833	153	0.93	M_2						21	25
			c						5.1	4.3
			n_2 Eck						694	694
			n_2 th						621	603
6.422	113	0.56	M_2				14	19	23	27
			c				5.6	4.3	3.4	2.9
			n_2 Eck				631	584	631	631
			n_2 th				631	584	631	631
7.025	113	0.47	M_2				15	20	25	30
			c				5.2	3.9	3.1	2.6
			n_2 Eck				577	534	577	577
			n_2 th				576	534	576	576
8.379	179	0.67	M_2					24	30	36
			c					5.2	4.2	3.5
			n_2 Eck					448	483	483
			n_2 th					434	416	404
9.333	165	0.61	M_2				20	27	34	40
			c				5.7	4.3	3.4	2.9
			n_2 Eck				434	402	434	434
			n_2 th				395	377	361	349
10.238	159	0.37	M_2				22	30	37	44
			c				5	3.8	3	2.6
			n_2 Eck				396	366	396	396
			n_2 th				396	366	396	396
11.491	181	0.41	M_2				25	34	41	49
			c				5.1	3.9	3.1	2.6
			n_2 Eck				353	326	353	353
			n_2 th				347	326	319	310
12.8	166	0.38	M_2				28	38	46	55
			c				4.2	3.2	2.5	2.1
			n_2 Eck				316	293	316	316
			n_2 th				302	289	277	269
14.706	182	0.28	M_2				32	43	53	64
			c				4	3	2.4	2
			n_2 Eck				275	255	275	275
			n_2 th				275	255	275	274
16.087	182	0.25	M_2			22	35	48	59	70
			c			5.6	3.6	2.8	2.2	1.9
			n_2 Eck			252	252	233	252	252
			n_2 th			252	252	233	252	252
17.92	167	0.23	M_2		20	25	39	53	66	78
			c		5.8	4.6	3	2.3	1.8	1.5
			n_2 Eck		226	226	226	209	226	226
			n_2 th		226	226	226	209	223	205

$M \dots$ [Nm]
 $n \dots$ [min^{-1}]
 $J \dots$ [kgcm^2]

$P \dots$ [kW]
 $I \dots$ [A]
 $i \dots$ [-]
 $c \dots$ [-]

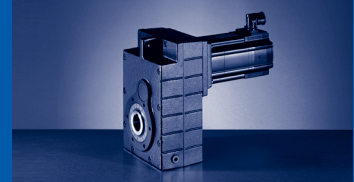

$M_{2GN} \leq 187 \text{ Nm}$

GFL04-2S				06CC41	06FC41	06IC41	09DC41	09FC38	09HC41	09LC41
				...S00	...S00	...S00	...S00	...S00	...S00	...S00
i	M_{2GN}	J_G	M_1	0.6	1.2	1.5	2.3	3.1	3.8	4.5
			n_1	4050	4050	4050	4050	3750	4050	4050
			I_{M230}	2.6	2.9	3.2	4.6	5	6.8	8.4
			I_{M400}	1.3	1.5	1.6	2.3	2.5	3.4	4.2
			P_N	0.25	0.51	0.64	1	1.2	1.6	1.9
			J_M	0.17	0.25	0.33	1.13	1.53	1.93	2.83
20.519	183	0.17	M_2		23	29	45	61	75	89
			c		5.5	4.4	2.9	2.2	1.7	1.5
			n_2 Eck		197	197	197	183	197	197
			n_2 th		197	197	197	183	197	197
22.857	167	0.16	M_2		26	32	50	68	84	100
			c		4.5	3.6	2.4	1.8	1.4	1.2
			n_2 Eck		177	177	177	164	177	177
			n_2 th		177	177	177	164	177	167
25.136	183	0.13	M_2		28	35	55	75	92	109
			c		5.1	4.1	2.7	2	1.6	1.4
			n_2 Eck		161	161	161	149	161	161
			n_2 th		161	161	161	149	161	161
28	168	0.12	M_2		32	40	62	84	103	122
			c		4.2	3.4	2.2	1.7	1.3	1.1
			n_2 Eck		145	145	145	134	145	145
			n_2 th		145	145	145	134	145	145
31.6	185	0.09	M_2		36	45				
			c		4.1	3.3				
			n_2 Eck		128	128				
			n_2 th		128	128				
35.2	170	0.08	M_2		40	50				
			c		3.4	2.7				
			n_2 Eck		115	115				
			n_2 th		115	115				
40.697	187	0.06	M_2		46	58				
			c		3.2	2.6				
			n_2 Eck		100	100				
			n_2 th		100	100				
45.333	172	0.06	M_2	25	52	65				
			c	5.3	2.7	2.1				
			n_2 Eck	89	89	89				
			n_2 th	89	89	89				

$M \dots$ [Nm]
 $n \dots$ [min^{-1}]
 $J \dots$ [kgcm^2]

$P \dots$ [kW]
 $I \dots$ [A]
 i [-]
 c [-]

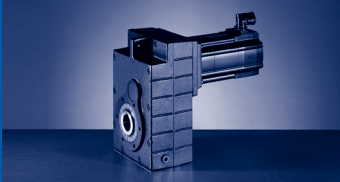

GFL [Nm]

GFL□□-□S (MCS)

$M_{2GN} \leq 345 \text{ Nm}$

GFL05-2S				06FC41	06IC41	09DC41	09FC38	09HC41	09LC41
				...S00	...S00	...S00	...S00	...S00	...S00
i	M_{2GN}	J_G	M_1						
			n_1	4050	4050	4050	3750	4050	4050
			I_{M230}	2.9	3.2	4.6	5	6.8	8.4
			I_{M400}	1.5	1.6	2.3	2.5	3.4	4.2
			P_N	0.51	0.64	1	1.2	1.6	1.9
			J_M	0.25	0.33	1.13	1.53	1.93	2.83
3.333	110	1.68	M_2						14
			c						5.4
			n_2 Eck						1215
			n_2 th					920	
3.333	150	1.68	M_2						
			c						
			n_2 Eck						
			n_2 th						
4.571	133	2.13	M_2					16	19
			c					5.7	4.8
			n_2 Eck					886	886
			n_2 th				790	766	
4.571	170	2.13	M_2						
			c						
			n_2 Eck						
			n_2 th						
5.133	170	2.37	M_2						21
			c						5.4
			n_2 Eck						789
			n_2 th					597	
5.133	223	2.37	M_2						
			c						
			n_2 Eck						
			n_2 th						
5.667	187	2.33	M_2						24
			c						5.4
			n_2 Eck						715
			n_2 th					541	
5.667	233	2.33	M_2						
			c						
			n_2 Eck						
			n_2 th						
6.4	149	0.82	M_2				18	23	27
			c				5.7	4.5	3.8
			n_2 Eck				586	633	633
			n_2 th				586	612	595
6.4	173	0.82	M_2						
			c						
			n_2 Eck						
			n_2 th						
7.04	205	1.47	M_2					25	30
			c					5.7	4.8
			n_2 Eck					575	575
			n_2 th				513	498	
7.04	248	1.47	M_2						
			c						
			n_2 Eck						
			n_2 th						
7.771	226	1.45	M_2					27	33
			c					5.7	4.8
			n_2 Eck					521	521
			n_2 th				465	451	

$M \dots$ [Nm]
 $n \dots$ [min^{-1}]
 $J \dots$ [kgcm^2]

$P \dots$ [kW]
 $I \dots$ [A]
 $i \dots$ [-]
 $c \dots$ [-]

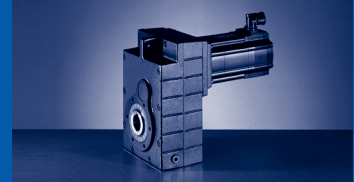

$M_{2GN} \leq 345 \text{ Nm}$

12DC20	12DC41	12HC15	12HC30	12HC35	12LC20	12LC41	GFL05-2S			
...500	...500	...500	...500	...500	...500	...500	M_1	J_G	M_{2GN}	i
5.5	4.3	10	8	7.5	13.5	11	n_1			
1950	4050	1500	3000	3525	1950	4050	I_{M230}			
5.2	8.8	7.6	10.5		11.8		I_{M400}			
2.6	4.5	3.8		5.7	5.9	10.2	P_N			
1.1	1.8	1.6	2.5	2.8	2.8	4.7	J_M			
4.12	4.12	7.42	7.42	7.42	10.72	10.72	M_2 c			
							$n_{2 \text{ Eck}}$	1.68	110	3.333
							$n_{2 \text{ th}}$			
		31	25	23	43	35	M_2 c			
		4.6	4.6	4.7	3.2	3	$n_{2 \text{ Eck}}$	1.68	150	3.333
		450	900	1058	585	1215	$n_{2 \text{ th}}$			
		450	891	893	585	819	M_2 c			
							$n_{2 \text{ Eck}}$	2.13	133	4.571
							$n_{2 \text{ th}}$			
		43	34	32	59	48	M_2 c			
		3.8	3.8	3.9	2.6	2.5	$n_{2 \text{ Eck}}$	2.13	170	4.571
		328	656	771	427	886	$n_{2 \text{ th}}$			
		328	656	736	427	676	M_2 c			
							$n_{2 \text{ Eck}}$	2.37	170	5.133
							$n_{2 \text{ th}}$			
		48	38	36	66	54	M_2 c			
		4.5	4.5	4.5	3	2.9	$n_{2 \text{ Eck}}$	2.37	223	5.133
		292	584	687	380	789	$n_{2 \text{ th}}$			
		292	575	576	380	528	M_2 c			
							$n_{2 \text{ Eck}}$	2.33	187	5.667
							$n_{2 \text{ th}}$			
		53	43	40	73	59	M_2 c			
		4.2	4.2	4.2	2.9	2.8	$n_{2 \text{ Eck}}$	2.33	233	5.667
		265	529	622	344	715	$n_{2 \text{ th}}$			
		265	515	516	344	473	M_2 c			
							$n_{2 \text{ Eck}}$	0.82	149	6.4
							$n_{2 \text{ th}}$			
33	26	61	49	46	83	68	M_2 c			
4.7	4.7	2.8	2.8	2.8	1.9	1.8	$n_{2 \text{ Eck}}$	0.82	173	6.4
305	633	234	469	551	305	633	$n_{2 \text{ th}}$			
305	614	234	469	551	305	508	M_2 c			
							$n_{2 \text{ Eck}}$	1.47	205	7.04
							$n_{2 \text{ th}}$			
		66	53	50	91	74	M_2 c			
		3.6	3.6	3.6	2.5	2.4	$n_{2 \text{ Eck}}$	1.47	248	7.04
		213	426	501	277	575	$n_{2 \text{ th}}$			
		213	426	473	277	434	M_2 c			
							$n_{2 \text{ Eck}}$	1.45	226	7.771
							$n_{2 \text{ th}}$			

M ... [Nm]
n ... [min⁻¹]
J ... [kgcm²]

P ... [kW]
I ... [A]
i [-]
c [-]

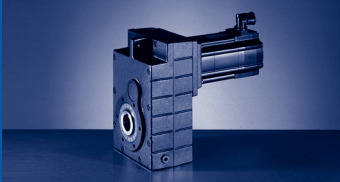

GFL [Nm]

GFL□□-□S (MCS)

$M_{2GN} \leq 345 \text{ Nm}$

GFL05-2S				06FC41	06IC41	09DC41	09FC38	09HC41	09LC41
				...500	...500	...500	...500	...500	...500
i	M_{2GN}	J_G	M_1						
			n_1	4050	4050	4050	3750	4050	4050
			I_{M230}	2.9	3.2	4.6	5	6.8	8.4
			I_{M400}	1.5	1.6	2.3	2.5	3.4	4.2
			P_N	0.51	0.64	1	1.2	1.6	1.9
			J_M	0.25	0.33	1.13	1.53	1.93	2.83
7.771	258	1.45	M_2 c n_2 Eck n_2 th						
9.01	220	0.95	M_2 c n_2 Eck n_2 th				26 6 416 416	32 4.8 450 423	38 4 450 411
9.01	266	0.95	M_2 c n_2 Eck n_2 th						
9.946	243	0.89	M_2 c n_2 Eck n_2 th				28 6 377 377	35 4.8 407 383	42 4 407 373
9.946	275	0.89	M_2 c n_2 Eck n_2 th						
11.36	278	1.08	M_2 c n_2 Eck n_2 th					40 4.8 357 308	48 4 357 299
12.8	285	1.01	M_2 c n_2 Eck n_2 th				37 5.5 293 280	46 4.3 316 269	54 3.7 316 260
14.538	301	0.75	M_2 c n_2 Eck n_2 th				42 5.1 258 258	52 4 279 255	62 3.4 279 248
15.904	310	0.6	M_2 c n_2 Eck n_2 th				46 4.8 236 236	57 3.8 255 239	68 3.2 255 232
17.92	312	0.61	M_2 c n_2 Eck n_2 th			38 5.6 226 226	52 4.3 209 209	64 3.4 226 208	77 2.9 226 202
20.286	333	0.43	M_2 c n_2 Eck n_2 th			43 5.3 200 200	59 4 185 185	73 3.2 200 200	87 2.7 200 200
22.857	313	0.43	M_2 c n_2 Eck n_2 th			49 4.4 177 177	67 3.4 164 164	83 2.7 177 177	99 2.3 177 177
24.85	344	0.35	M_2 c n_2 Eck n_2 th			53 5.1 163 163	73 3.9 151 151	90 3.1 163 163	107 2.6 163 163

$M \dots$ [Nm]
 $n \dots$ [min^{-1}]
 $J \dots$ [kgcm^2]

$P \dots$ [kW]
 $I \dots$ [A]
 $i \dots$ [-]
 $c \dots$ [-]

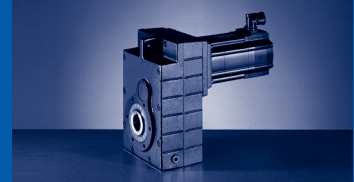

$M_{2GN} \leq 345 \text{ Nm}$

12DC20	12DC41	12HC15	12HC30	12HC35	12LC20	12LC41	GFL05-2S			
...500	...500	...500	...500	...500	...500	...500	M_1	J_G	M_{2GN}	i
5.5	4.3	10	8	7.5	13.5	11	n_1			
1950	4050	1500	3000	3525	1950	4050	l_{M230}			
5.2	8.8	7.6	10.5		11.8		l_{M400}			
2.6	4.5	3.8		5.7	5.9	10.2	P_N			
1.1	1.8	1.6	2.5	2.8	2.8	4.7	J_M			
4.12	4.12	7.42	7.42	7.42	10.72	10.72	M_2			
39	31	74	59	55	100	82	c	1.45	258	7.771
5.7	5.7	3.4	3.4	3.4	2.3	2.2	$n_{2\text{Eck}}$			
251	521	193	386	454	251	521	$n_{2\text{th}}$			
251	466	193	386	424	251	388	M_2			
							c	0.95	220	9.01
							$n_{2\text{Eck}}$			
							$n_{2\text{th}}$			
46	36	86	68	64	117	95	M_2			
5.1	5.1	3	3	3.1	2.1	2	c	0.95	266	9.01
216	450	167	333	391	216	450	$n_{2\text{Eck}}$			
216	428	166	333	391	216	362	$n_{2\text{th}}$			
							M_2			
							c	0.89	243	9.946
							$n_{2\text{Eck}}$			
							$n_{2\text{th}}$			
51	40	95	76	71	129	105	M_2			
4.7	4.8	2.9	2.8	2.9	1.9	1.9	c	0.89	275	9.946
196	407	151	302	354	196	407	$n_{2\text{Eck}}$			
196	383	151	302	350	196	317	$n_{2\text{th}}$			
59	46	108	87	81	148	120	M_2			
4.2	4.2	2.5	2.5	2.5	1.7	1.7	c	1.08	278	11.36
172	357	132	264	310	172	357	$n_{2\text{Eck}}$			
172	301	132	264	273	172	234	$n_{2\text{th}}$			
66	52	123	98	92	167	136	M_2			
3.8	3.8	2.3	2.3	2.3	1.6	1.5	c	1.01	285	12.8
152	316	117	234	275	152	316	$n_{2\text{Eck}}$			
152	263	117	234	237	152	197	$n_{2\text{th}}$			
76	59	139	112	105	190	155	M_2			
3.6	3.6	2.1	2.1	2.1	1.5	1.4	c	0.75	301	14.538
134	279	103	206	243	134	279	$n_{2\text{Eck}}$			
134	250	103	206	227	134	188	$n_{2\text{th}}$			
83	65	153	122	115	208	169	M_2			
3.4	3.4	2	2	2	1.4	1.3	c	0.6	310	15.904
123	255	94	189	222	123	255	$n_{2\text{Eck}}$			
123	234	94	189	213	123	176	$n_{2\text{th}}$			
94	73	172	138	129	234	191	M_2			
3	3	1.8	1.8	1.8	1.2	1.2	c	0.61	312	17.92
109	226	84	167	197	109	226	$n_{2\text{Eck}}$			
109	204	84	167	180	109	149	$n_{2\text{th}}$			
106	83	195	156	147	265	216	M_2			
2.8	2.8	1.7	1.7	1.7	1.2	1.1	c	0.43	333	20.286
96	200	74	148	174	96	200	$n_{2\text{Eck}}$			
96	200	74	148	174	96	151	$n_{2\text{th}}$			
120	94	221	177	166			M_2			
2.4	2.4	1.4	1.4	1.4			c	0.43	313	22.857
85	177	66	131	154			$n_{2\text{Eck}}$			
85	177	66	131	149			$n_{2\text{th}}$			
130	102	240	192	180	325	265	M_2			
2.6	2.7	1.4	1.6	1.6	1.1	1.1	c	0.35	344	24.85
79	163	60	121	142	79	163	$n_{2\text{Eck}}$			
78	163	60	121	142	78	138	$n_{2\text{th}}$			

M ... [Nm]
n ... [min⁻¹]
J ... [kgcm²]

P ... [kW]
I ... [A]
i [-]
c [-]

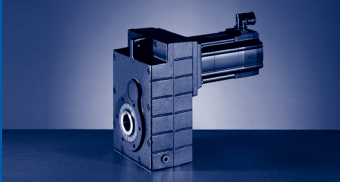

GFL [Nm]

GFL□□-□S (MCS)

$M_{2GN} \leq 345 \text{ Nm}$

GFL05-2S				06FC41	06IC41	09DC41	09FC38	09HC41	09LC41
				...500	...500	...500	...500	...500	...500
i	M_{2GN}	J_G	M_1						
			n_1	4050	4050	4050	3750	4050	4050
			I_{M230}	2.9	3.2	4.6	5	6.8	8.4
			I_{M400}	1.5	1.6	2.3	2.5	3.4	4.2
			P_N	0.51	0.64	1	1.2	1.6	1.9
			J_M	0.25	0.33	1.13	1.53	1.93	2.83
28	314	0.33	M_2			60	82	102	121
			c			4.1	3.1	2.5	2.1
			n_2 Eck			145	134	145	145
			n_2 th			145	134	145	145
32.344	296	0.2	M_2		45				
			c		5.1				
			n_2 Eck		125				
			n_2 th		125				
32.344	345	0.2	M_2			70	95	118	140
			c			3.9	3	2.4	2
			n_2 Eck			125	116	125	125
			n_2 th			125	116	125	125
36.444	316	0.2	M_2		51	80	108	133	158
			c		4.9	3.2	2.4	1.9	1.6
			n_2 Eck		111	111	103	111	111
			n_2 th		111	111	103	111	111
40.233	307	0.15	M_2	45	57				
			c	5.4	4.3				
			n_2 Eck	101	101				
			n_2 th	101	101				
40.233	345	0.15	M_2			88	119	147	175
			c			3.1	2.4	1.9	1.6
			n_2 Eck			101	93	101	101
			n_2 th			101	93	101	101
45.333	319	0.14	M_2	51	64	100	135	166	197
			c	4.9	4	2.6	2	1.6	1.3
			n_2 Eck	89	89	89	83	89	89
			n_2 th	89	89	89	83	89	89
52.067	309	0.09	M_2	59	74				
			c	4.2	3.3				
			n_2 Eck	78	78				
			n_2 th	78	78				
58.667	322	0.09	M_2	66	84				
			c	3.9	3.1				
			n_2 Eck	69	69				
			n_2 th	69	69				
63.19	282	0.07	M_2	72	91				
			c	3.1	2.5				
			n_2 Eck	64	64				
			n_2 th	64	64				
71.2	305	0.06	M_2	81	102				
			c	3.3	2.7				
			n_2 Eck	57	57				
			n_2 th	57	57				

$M \dots$ [Nm]
 $n \dots$ [min^{-1}]
 $J \dots$ [kgcm^2]

$P \dots$ [kW]
 $I \dots$ [A]
 $i \dots$ [-]
 $c \dots$ [-]

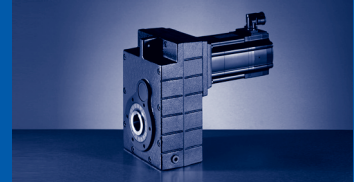

$M_{2GN} \leq 345 \text{ Nm}$

12DC20	12DC41	12HC15	12HC30	12HC35	12LC20	12LC41	GFL05-2S			
...500	...500	...500	...500	...500	...500	...500				
5.5	4.3	10	8	7.5	13.5	11	M_1	J_G	M_{2GN}	i
1950	4050	1500	3000	3525	1950	4050	n_1			
5.2	8.8	7.6	10.5		11.8		I_{M230}			
2.6	4.5	3.8		5.7	5.9	10.2	I_{M400}			
1.1	1.8	1.6	2.5	2.8	2.8	4.7	P_N			
4.12	4.12	7.42	7.42	7.42	10.72	10.72	J_M			
148	115	271	217	203			M_2			
2.1	2.2	1.2	1.3	1.3			c			
70	145	54	107	126			$n_{2 \text{ Eck}}$	0.33	314	28
70	145	54	107	126			$n_{2 \text{ th}}$			
							M_2			
							c			
							$n_{2 \text{ Eck}}$	0.2	296	32.344
							$n_{2 \text{ th}}$			
							M_2			
							c			
							$n_{2 \text{ Eck}}$	0.2	345	32.344
							$n_{2 \text{ th}}$			
							M_2			
							c			
							$n_{2 \text{ Eck}}$	0.2	316	36.444
							$n_{2 \text{ th}}$			
							M_2			
							c			
							$n_{2 \text{ Eck}}$	0.15	307	40.233
							$n_{2 \text{ th}}$			
							M_2			
							c			
							$n_{2 \text{ Eck}}$	0.15	345	40.233
							$n_{2 \text{ th}}$			
							M_2			
							c			
							$n_{2 \text{ Eck}}$	0.14	319	45.333
							$n_{2 \text{ th}}$			
							M_2			
							c			
							$n_{2 \text{ Eck}}$	0.09	309	52.067
							$n_{2 \text{ th}}$			
							M_2			
							c			
							$n_{2 \text{ Eck}}$	0.09	322	58.667
							$n_{2 \text{ th}}$			
							M_2			
							c			
							$n_{2 \text{ Eck}}$	0.07	282	63.19
							$n_{2 \text{ th}}$			
							M_2			
							c			
							$n_{2 \text{ Eck}}$	0.06	305	71.2
							$n_{2 \text{ th}}$			

M ... [Nm]
n ... [min⁻¹]
J ... [kgcm²]

P ... [kW]
I ... [A]
i [-]
c [-]

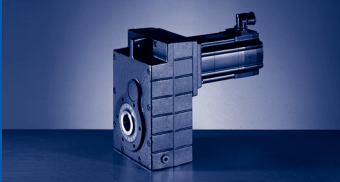

GFL [Nm]

GFL□□-□S (MCS)

$M_{2GN} \leq 345 \text{ Nm}$

GFL05-3S				06CC41	06FC41	06IC41	09DC41	09FC38
				...500	...500	...500	...500	...500
i	M_{2GN}	J_G	M_1					
			n_1	4050	4050	4050	4050	3750
			I_{M230}	2.6	2.9	3.2	4.6	5
			I_{M400}	1.3	1.5	1.6	2.3	2.5
			P_N	0.25	0.51	0.64	1	1.2
			J_M	0.17	0.25	0.33	1.13	1.53
61.653	207	0.2	M_2	34	70	88	135	
			c	4.8	2.4	1.9	1.3	
			n_2 Eck	66	66	66	66	
			n_2 th	66	66	66	66	
78.639	225	0.14	M_2	43	89	112	173	
			c	4.5	2.3	1.8	1.2	
			n_2 Eck	52	52	52	52	
			n_2 th	52	52	52	52	
90.123	303	0.2	M_2	49	102	128	197	267
			c	5.3	2.7	2.1	1.4	1.1
			n_2 Eck	45	45	45	45	42
			n_2 th	45	45	45	45	42
101.547	328	0.2	M_2	56	115	144	222	301
			c	5.1	2.6	2	1.3	1
			n_2 Eck	40	40	40	40	37
			n_2 th	40	40	40	40	37
114.952	329	0.14	M_2	63	130	163	252	
			c	4.5	2.3	1.8	1.2	
			n_2 Eck	35	35	35	35	
			n_2 th	35	35	35	35	
129.524	328	0.14	M_2	72	147	185	285	
			c	4	2	1.6	1	
			n_2 Eck	31	31	31	31	
			n_2 th	31	31	31	31	
140.817	345	0.11	M_2	78	160	201	309	
			c	3.9	1.9	1.6	1	
			n_2 Eck	29	29	29	29	
			n_2 th	29	29	29	29	
158.667	328	0.11	M_2	89	181	227		
			c	3.3	1.6	1.3		
			n_2 Eck	26	26	26		
			n_2 th	26	26	26		
177.027	345	0.07	M_2	99	202	253		
			c	3.1	1.5	1.2		
			n_2 Eck	23	23	23		
			n_2 th	23	23	23		
199.467	328	0.07	M_2	112	228	286		
			c	2.6	1.3	1		
			n_2 Eck	20	20	20		
			n_2 th	20	20	20		
227.989	345	0.05	M_2	129	261			
			c	2.4	1.2			
			n_2 Eck	18	18			
			n_2 th	18	18			
256.889	328	0.05	M_2	146	295			
			c	2	1			
			n_2 Eck	16	16			
			n_2 th	16	16			

$M \dots$ [Nm]
 $n \dots$ [min^{-1}]
 $J \dots$ [kgcm^2]

$P \dots$ [kW]
 $I \dots$ [A]
 i [-]
 c [-]

GFL [Nm]
GFL□□-□S (MCS)

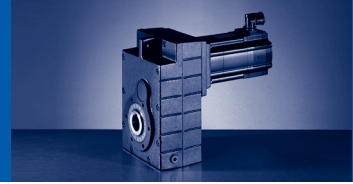

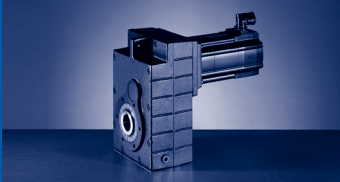

GFL [Nm]

GFL□□-□S (MCS)

$M_{2GN} \leq 657 \text{ Nm}$

GFL06-2S				06FC41	06IC41	09DC41	09FC38	09HC41	09LC41	12DC20	12DC41	12HC15	12HC30
				...500	...500	...500	...500	...500	...500	...500	...500	...500	...500
i	M_{2GN}	J_G	M_1	1.2	1.5	2.3	3.1	3.8	4.5	5.5	4.3	10	8
			n_1	4050	4050	4050	3750	4050	4050	1950	4050	1500	3000
			I_{M230}	2.9	3.2	4.6	5	6.8	8.4	5.2	8.8	7.6	10.5
			I_{M400}	1.5	1.6	2.3	2.5	3.4	4.2	2.6	4.5	3.8	
			P_N	0.51	0.64	1	1.2	1.6	1.9	1.1	1.8	1.6	2.5
			J_M	0.25	0.33	1.13	1.53	1.93	2.83	4.12	4.12	7.42	7.42
3.675	205	7.76	M_2									34	27
			c									5.8	5.7
			n_2 Eck									408	816
			n_2 th									408	714
3.675	317	7.76	M_2										
			c										
			n_2 Eck										
			n_2 th										
5.211	291	6.64	M_2									48	38
			c									5.8	5.7
			n_2 Eck									288	576
			n_2 th									288	503
5.211	424	6.64	M_2										
			c										
			n_2 Eck										
			n_2 th										
5.75	321	6.04	M_2									53	42
			c									5.8	5.7
			n_2 Eck									261	522
			n_2 th									261	456
5.75	442	6.04	M_2										
			c										
			n_2 Eck										
			n_2 th										
6.45	195	3.65	M_2					23	27				
			c					5.9	5				
			n_2 Eck					628	628				
			n_2 th					548	531				
6.45	252	3.65	M_2									61	49
			c									4	4
			n_2 Eck									233	465
			n_2 th									233	465
6.45	352	3.65	M_2										
			c										
			n_2 Eck										
			n_2 th										
7.147	333	4.04	M_2									67	53
			c									4.8	4.8
			n_2 Eck									210	420
			n_2 th									210	410
7.147	433	4.04	M_2										
			c										
			n_2 Eck										
			n_2 th										
8.4	469	4.26	M_2									78	62
			c									5.8	5.7
			n_2 Eck									179	357
			n_2 th									179	312
8.4	604	4.26	M_2										
			c										
			n_2 Eck										
			n_2 th										

$M \dots$ [Nm]
 $n \dots$ [min^{-1}]
 $J \dots$ [kgcm^2]

$P \dots$ [kW]
 $I \dots$ [A]
 $i [-]$
 $c [-]$

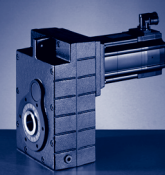

$M_{2GN} \leq 657 \text{ Nm}$

12HC35	12LC20	12LC41	14DC15	14DC36	14HC15	14HC32	14LC15	14LC32	14PC14	14PC32	GFL06-2S			
...500	...500	...500	...500	...500	...500	...500	...500	...500	...500	...500	M_1	J_G	M_{2GN}	i
7.5	13.5	11	9.2	7.5	16	14	23	17.2	30	21	n_1			
3525	1950	4050	1500	3600	1500	3225	1500	3225	1350	3225	I_{M230}			
	11.8										I_{M400}			
5.7	5.9	10.2	4.5	7.5	6.6	11.9	9.7	15	10.8	15.6	P_N			
2.8	2.8	4.7	1.45	2.8	2.5	4.7	3.6	5.8	4.2	7.1	J_M			
7.42	10.72	10.72	8.22	8.22	14.32	14.32	23.44	23.44	34.74	34.82	M_2			
25	47	38									c	7.76	205	3.675
5.8	3.9	3.8									n_2 Eck			
959	531	1102									n_2 th			
715	531	656												
					54	48	80	59	105	73	M_2			
					5.6	4.9	3.9	4	3	3.3	c	7.76	317	3.675
					408	878	408	878	367	878	n_2 Eck			
					408	693	408	665	367	637	n_2 th			
36	66	54									M_2			
5.8	3.9	3.8									c	6.64	291	5.211
676	374	777									n_2 Eck			
505	374	463									n_2 th			
					77	68	113	84	149	104	M_2			
					5.2	4.6	3.6	3.8	2.8	3.1	c	6.64	424	5.211
					288	619	288	619	259	619	n_2 Eck			
					288	483	288	463	259	443	n_2 th			
40	73	60									M_2			
5.8	3.9	3.8									c	6.04	321	5.75
613	339	704									n_2 Eck			
457	339	419									n_2 th			
					86	75	125	93	165	115	M_2			
					5	4.4	3.4	3.6	2.6	2.9	c	6.04	442	5.75
					261	561	261	561	235	561	n_2 Eck			
					261	433	261	415	235	397	n_2 th			
											M_2			
											c	3.65	195	6.45
											n_2 Eck			
											n_2 th			
45	83	68									M_2			
4.1	2.7	2.6									c	3.65	252	6.45
547	302	628									n_2 Eck			
510	302	468									n_2 th			
				45	98	86	142	106	186	130	M_2			
				5.6	3.5	3.1	2.4	2.5	1.9	2.1	c	3.65	352	6.45
				558	233	500	233	500	209	500	n_2 Eck			
				542	233	484	233	464	209	444	n_2 th			
50	91	75									M_2			
4.8	3.3	3.1									c	4.04	333	7.147
493	273	567									n_2 Eck			
411	273	377									n_2 th			
					108	95	157	117	206	144	M_2			
					3.9	3.5	2.7	2.8	2.1	2.3	c	4.04	433	7.147
					210	451	210	451	189	451	n_2 Eck			
					210	385	210	369	189	353	n_2 th			
58	107	87									M_2			
5.8	3.9	3.8									c	4.26	469	8.4
420	232	482									n_2 Eck			
313	232	287									n_2 th			
					126	110	183	137	241	168	M_2			
					4.6	4.1	3.2	3.3	2.5	2.7	c	4.26	604	8.4
					179	384	179	384	161	384	n_2 Eck			
					179	292	179	280	161	268	n_2 th			

M ... [Nm]
n ... [min⁻¹]
J ... [kgcm²]

P ... [kW]
I ... [A]
i [-]
c [-]

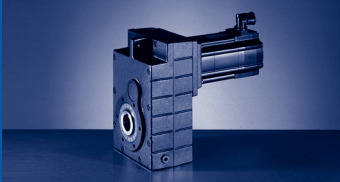

GFL [Nm]

GFL□□-□S (MCS)

$M_{2GN} \leq 657 \text{ Nm}$

GFL06-2S				06FC41	06IC41	09DC41	09FC38	09HC41	09LC41	12DC20	12DC41	12HC15	12HC30		
				...500	...500	...500	...500	...500	...500	...500	...500	...500	...500		
i	M_{2GN}	J_G	M_1	1.2	1.5	2.3	3.1	3.8	4.5	5.5	4.3	10	8		
			n_1	4050	4050	4050	3750	4050	4050	1950	4050	1500	3000		
			I_{M230}	2.9	3.2	4.6	5	6.8	8.4	5.2	8.8	7.6	10.5		
			I_{M400}	1.5	1.6	2.3	2.5	3.4	4.2	2.6	4.5	3.8			
			P_N	0.51	0.64	1	1.2	1.6	1.9	1.1	1.8	1.6	2.5		
			J_M	0.25	0.33	1.13	1.53	1.93	2.83	4.12	4.12	7.42	7.42		
9.463	529	3.88	M_2									87	70		
			c										5.8	5.7	
			n_2 Eck											159	317
			n_2 th											159	277
9.463	581	3.88	M_2												
			c												
			n_2 Eck												
			n_2 th												
10.092	306	2.52	M_2					35	42						
			c					5.9	5						
			n_2 Eck					401	401						
			n_2 th					350	339						
10.092	395	2.52	M_2									95	76		
			c										4	4	
			n_2 Eck										149	297	
			n_2 th										149	297	
10.092	459	2.52	M_2												
			c												
			n_2 Eck												
			n_2 th												
11.52	536	1.73	M_2									107	86		
			c										4.8	4.8	
			n_2 Eck										130	260	
			n_2 th										130	255	
11.52	632	1.73	M_2												
			c												
			n_2 Eck												
			n_2 th												
12.978	592	2.61	M_2									121	97		
			c										4.7	4.7	
			n_2 Eck										116	231	
			n_2 th										116	225	
14.743	447	1.95	M_2					52	62						
			c					5.9	5						
			n_2 Eck					275	275						
			n_2 th					240	232						
14.743	577	1.95	M_2									139	111		
			c										4	4	
			n_2 Eck										102	204	
			n_2 th										102	203	
14.743	641	1.95	M_2												
			c												
			n_2 Eck												
			n_2 th												
16.128	467	1.68	M_2					57	68						
			c					5.6	4.8						
			n_2 Eck					251	251						
			n_2 th					224	217						
16.128	603	1.68	M_2									152	122		
			c										3.9	3.8	
			n_2 Eck										93	186	
			n_2 th										93	186	

$M \dots$ [Nm]
 $n \dots$ [min^{-1}]
 $J \dots$ [kgcm^2]

$P \dots$ [kW]
 $I \dots$ [A]
 i [-]
 c [-]

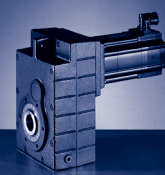

$M_{2GN} \leq 657 \text{ Nm}$

12HC35	12LC20	12LC41	14DC15	14DC36	14HC15	14HC32	14LC15	14LC32	14PC14	14PC32	GFL06-2S			
...S00	...S00	...S00	...S00	...S00	...S00	...S00	...S00	...S00	...S00	...S00	M_1	J_G	M_{2GN}	i
7.5	13.5	11	9.2	7.5	16	14	23	17.2	30	21	n_1			
3525	1950	4050	1500	3600	1500	3225	1500	3225	1350	3225	I_{M230}			
	11.8										I_{M400}			
5.7	5.9	10.2	4.5	7.5	6.6	11.9	9.7	15	10.8	15.6	P_N			
2.8	2.8	4.7	1.45	2.8	2.5	4.7	3.6	5.8	4.2	7.1	J_M			
7.42	10.72	10.72	8.22	8.22	14.32	14.32	23.44	23.44	34.74	34.82	M_2			
65	120	98									c	3.88	529	9.463
5.8	3.9	3.8									$n_{2 \text{ Eck}}$			
373	206	428									$n_{2 \text{ th}}$			
278	206	255												
					142	125	207	155	272	190	M_2			
					4	3.5	2.8	2.9	2.1	2.3	c	3.88	581	9.463
					159	341	159	341	143	341	$n_{2 \text{ Eck}}$			
					159	251	159	240	143	229	$n_{2 \text{ th}}$			
											M_2			
											c	2.52	306	10.092
											$n_{2 \text{ Eck}}$			
											$n_{2 \text{ th}}$			
71	130	106									M_2			
4.1	2.7	2.6									c	2.52	395	10.092
349	193	401									$n_{2 \text{ Eck}}$			
326	193	299									$n_{2 \text{ th}}$			
			86	71	154	135	223	166	292	204	M_2			
			5.1	4.7	2.9	2.6	2	2.1	1.6	1.7	c	2.52	459	10.092
			149	357	149	320	149	320	134	320	$n_{2 \text{ Eck}}$			
			149	335	149	298	149	285	134	259	$n_{2 \text{ th}}$			
81	147	120									M_2			
4.8	3.3	3.1									c	1.73	536	11.52
306	169	352									$n_{2 \text{ Eck}}$			
255	169	234									$n_{2 \text{ th}}$			
				80	174	153	253	189	332	232	M_2			
				5.6	3.5	3.1	2.5	2.6	1.9	2.1	c	1.73	632	11.52
				313	130	280	130	280	117	280	$n_{2 \text{ Eck}}$			
				263	130	234	130	224	117	214	$n_{2 \text{ th}}$			
91	166	136	111	91	197	173	286	214	376	262	M_2			
4.7	3.2	3.1	5.1	4.7	2.9	2.6	2	2.1	1.6	1.7	c	2.61	592	12.978
272	150	312	116	277	116	249	116	249	104	249	$n_{2 \text{ Eck}}$			
226	150	207	116	225	116	199	116	190	104	174	$n_{2 \text{ th}}$			
											M_2			
											c	1.95	447	14.743
											$n_{2 \text{ Eck}}$			
											$n_{2 \text{ th}}$			
104	190	155									M_2			
4.1	2.7	2.6									c	1.95	577	14.743
239	132	275									$n_{2 \text{ Eck}}$			
223	132	205									$n_{2 \text{ th}}$			
			126	103	225	197	326	243	427	298	M_2			
			4.9	4.5	2.8	2.5	2	2	1.5	1.7	c	1.95	641	14.743
			102	244	102	219	102	219	92	219	$n_{2 \text{ Eck}}$			
			102	227	102	202	102	193	92	173	$n_{2 \text{ th}}$			
											M_2			
											c	1.68	467	16.128
											$n_{2 \text{ Eck}}$			
											$n_{2 \text{ th}}$			
114	208	169									M_2			
3.9	2.6	2.5									c	1.68	603	16.128
219	121	251									$n_{2 \text{ Eck}}$			
209	121	192									$n_{2 \text{ th}}$			

$M \dots$ [Nm]
 $n \dots$ [min^{-1}]
 $J \dots$ [kgcm^2]

$P \dots$ [kW]
 $I \dots$ [A]
 $i [-]$
 $c [-]$

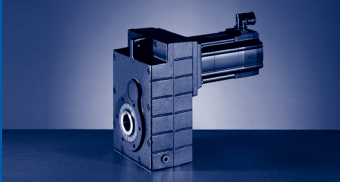

GFL [Nm]

GFL□□-□S (MCS)

$M_{2GN} \leq 657 \text{ Nm}$

GFL06-2S				06FC41	06IC41	09DC41	09FC38	09HC41	09LC41	12DC20	12DC41	12HC15	12HC30
				...500	...500	...500	...500	...500	...500	...500	...500	...500	...500
i	M_{2GN}	J_G	M_1	1.2	1.5	2.3	3.1	3.8	4.5	5.5	4.3	10	8
			n_1	4050	4050	4050	3750	4050	4050	1950	4050	1500	3000
			I_{M230}	2.9	3.2	4.6	5	6.8	8.4	5.2	8.8	7.6	10.5
			I_{M400}	1.5	1.6	2.3	2.5	3.4	4.2	2.6	4.5	3.8	
			P_N	0.51	0.64	1	1.2	1.6	1.9	1.1	1.8	1.6	2.5
			J_M	0.25	0.33	1.13	1.53	1.93	2.83	4.12	4.12	7.42	7.42
16.128	643	1.68	M_2 c $n_{2 \text{ Eck}}$ $n_{2 \text{ th}}$										
18.169	526	1.57	M_2 c $n_{2 \text{ Eck}}$ $n_{2 \text{ th}}$					64 5.6 223 199	76 4.8 223 193				
18.169	600	1.57	M_2 c $n_{2 \text{ Eck}}$ $n_{2 \text{ th}}$							92 5.7 107 107	72 5.7 223 199	172 3.4 83 83	138 3.4 165 165
20.571	501	1.19	M_2 c $n_{2 \text{ Eck}}$ $n_{2 \text{ th}}$				59 6 182 182	73 4.8 197 187	87 4 197 182				
20.571	645	1.19	M_2 c $n_{2 \text{ Eck}}$ $n_{2 \text{ th}}$							105 5.4 95 95	82 5.4 197 191	195 3.2 73 73	156 3.2 146 146
23.175	565	1.13	M_2 c $n_{2 \text{ Eck}}$ $n_{2 \text{ th}}$				66 6 162 162	82 4.8 175 166	98 4 175 161				
23.175	604	1.13	M_2 c $n_{2 \text{ Eck}}$ $n_{2 \text{ th}}$							119 4.5 84 84	93 4.5 175 164	221 2.7 65 65	177 2.7 130 129
25.2	527	0.9	M_2 c $n_{2 \text{ Eck}}$ $n_{2 \text{ th}}$				72 5.8 149 149	89 4.6 161 161	107 3.9 161 161				
25.2	651	0.9	M_2 c $n_{2 \text{ Eck}}$ $n_{2 \text{ th}}$							129 4.8 77 77	101 5.1 161 161	240 2.7 60 60	192 3 119 119
28.389	594	0.86	M_2 c $n_{2 \text{ Eck}}$ $n_{2 \text{ th}}$				81 5.8 132 132	101 4.6 143 143	120 3.9 143 143				
28.389	607	0.86	M_2 c $n_{2 \text{ Eck}}$ $n_{2 \text{ th}}$							147 4 69 69	115 4.2 143 143	272 2.2 53 53	217 2.5 106 106
32.8	550	0.58	M_2 c $n_{2 \text{ Eck}}$ $n_{2 \text{ th}}$				95 4.7 114 114	118 3.7 124 123	140 3.1 124 123				
32.8	641	0.58	M_2 c $n_{2 \text{ Eck}}$ $n_{2 \text{ th}}$							170 3.7 60 59	133 3.8 124 123	315 2 46 46	251 2.3 92 91

$M \dots$ [Nm]
 $n \dots$ [min^{-1}]
 $J \dots$ [kgcm^2]

$P \dots$ [kW]
 $I \dots$ [A]
 $i \dots$ [-]
 $c \dots$ [-]

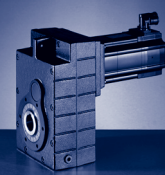

$M_{2GN} \leq 657 \text{ Nm}$

12HC35	12LC20	12LC41	14DC15	14DC36	14HC15	14HC32	14LC15	14LC32	14PC14	14PC32	GFL06-2S			
...S00	...S00	...S00	...S00	...S00	...S00	...S00	...S00	...S00	...S00	...S00	M_1	J_G	M_{2GN}	i
7.5	13.5	11	9.2	7.5	16	14	23	17.2	30	21	n_1			
3525	1950	4050	1500	3600	1500	3225	1500	3225	1350	3225	I_{M230}			
	11.8										I_{M400}			
5.7	5.9	10.2	4.5	7.5	6.6	11.9	9.7	15	10.8	15.6	P_N			
2.8	2.8	4.7	1.45	2.8	2.5	4.7	3.6	5.8	4.2	7.1	J_M			
7.42	10.72	10.72	8.22	8.22	14.32	14.32	23.44	23.44	34.74	34.82	M_2			
			139	114	246	216	357	267	468	327	c	1.68	643	16.128
			4.5	4.1	2.6	2.3	1.8	1.9	1.4	1.5	$n_{2 \text{ Eck}}$			
			93	223	93	200	93	200	84	200	$n_{2 \text{ th}}$			
			93	211	93	188	93	176	84	157	M_2			
											c	1.57	526	18.169
											$n_{2 \text{ Eck}}$			
											$n_{2 \text{ th}}$			
129	235	191	158	129	279	245	403	302	528	369	M_2			
3.4	2.3	2.2	3.7	3.4	2.1	1.9	1.5	1.5	1.1	1.3	c	1.57	600	18.169
194	107	223	83	198	83	178	83	178	74	178	$n_{2 \text{ Eck}}$			
181	107	166	83	181	83	158	83	141	74	127	$n_{2 \text{ th}}$			
											M_2			
											c	1.19	501	20.571
											$n_{2 \text{ Eck}}$			
											$n_{2 \text{ th}}$			
146	266	217	179	146	316	277	457	342	598	418	M_2			
3.2	2.2	2.1	3.5	3.2	2	1.8	1.4	1.5	1.1	1.2	c	1.19	645	20.571
171	95	197	73	175	73	157	73	157	66	157	$n_{2 \text{ Eck}}$			
171	95	162	73	175	73	152	73	138	66	126	$n_{2 \text{ th}}$			
											M_2			
											c	1.13	565	23.175
											$n_{2 \text{ Eck}}$			
											$n_{2 \text{ th}}$			
166	301	245	203	166	357	313	516	386			M_2			
2.7	1.8	1.8	2.9	2.7	1.7	1.5	1.2	1.2			c	1.13	604	23.175
152	84	175	65	155	65	139	65	139			$n_{2 \text{ Eck}}$			
150	84	134	65	150	65	123	65	113			$n_{2 \text{ th}}$			
											M_2			
											c	0.9	527	25.2
											$n_{2 \text{ Eck}}$			
											$n_{2 \text{ th}}$			
180	327	266	221	180	389	340	561	419		513	M_2			
3	2	2	2.9	3	1.7	1.7	1.2	1.4		1.1	c	0.9	651	25.2
140	77	161	60	143	60	128	60	128		128	$n_{2 \text{ Eck}}$			
140	77	154	60	142	60	128	60	127		115	$n_{2 \text{ th}}$			
											M_2			
											c	0.86	594	28.389
											$n_{2 \text{ Eck}}$			
											$n_{2 \text{ th}}$			
203	369	301	250	203	439	384		473			M_2			
2.5	1.6	1.6	2.4	2.5	1.4	1.4		1.1			c	0.86	607	28.389
124	69	143	53	127	53	114		114			$n_{2 \text{ Eck}}$			
124	69	123	53	126	53	113		103			$n_{2 \text{ th}}$			
											M_2			
											c	0.58	550	32.8
											$n_{2 \text{ Eck}}$			
											$n_{2 \text{ th}}$			
235	427	348									M_2			
2.3	1.5	1.5									c	0.58	641	32.8
108	60	124									$n_{2 \text{ Eck}}$			
107	59	119									$n_{2 \text{ th}}$			

$M \dots$ [Nm]
 $n \dots$ [min^{-1}]
 $J \dots$ [kgcm^2]

$P \dots$ [kW]
 $I \dots$ [A]
 $i [-]$
 $c [-]$

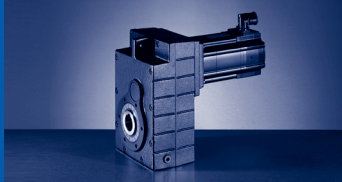

GFL [Nm]

GFL□□-□S (MCS)

$M_{2GN} \leq 657 \text{ Nm}$

GFL06-2S				06FC41	06IC41	09DC41	09FC38	09HC41	09LC41	12DC20	12DC41	12HC15	12HC30	
				...500	...500	...500	...500	...500	...500	...500	...500	...500	...500	
i	M_{2GN}	J_G	M_1	1.2	1.5	2.3	3.1	3.8	4.5	5.5	4.3	10	8	
			n_1	4050	4050	4050	3750	4050	4050	1950	4050	1500	3000	
			I_{M230}	2.9	3.2	4.6	5	6.8	8.4	5.2	8.8	7.6	10.5	
			I_{M400}	1.5	1.6	2.3	2.5	3.4	4.2	2.6	4.5	3.8		
			P_N	0.51	0.64	1	1.2	1.6	1.9	1.1	1.8	1.6	2.5	
			J_M	0.25	0.33	1.13	1.53	1.93	2.83	4.12	4.12	7.42	7.42	
36.951	611	0.56	M_2				107	132	158	193	151	356	284	
			c			4.6	3.7	3.1	3.1	3.2	1.7	1.7	1.9	
			$n_{2 \text{ Eck}}$			102	110	110	110	53	110	41	81	81
			$n_{2 \text{ th}}$			101	110	110	110	53	110	41	81	81
40.8	386	0.43	M_2		57									
			c		5.3									
			$n_{2 \text{ Eck}}$		99									
			$n_{2 \text{ th}}$		99									
40.8	571	0.43	M_2			87	119	147	175					
			c			5.1	3.9	3.1	2.6					
			$n_{2 \text{ Eck}}$			99	92	99	99					
			$n_{2 \text{ th}}$			99	92	99	99					
40.8	657	0.43	M_2							213	166	393	314	
			c							3	3.2	1.7	1.9	
			$n_{2 \text{ Eck}}$							48	99	37	74	
			$n_{2 \text{ th}}$							48	99	37	74	
45.963	435	0.41	M_2		64									
			c		5.3									
			$n_{2 \text{ Eck}}$		88									
			$n_{2 \text{ th}}$		88									
45.963	613	0.41	M_2			98	134	166	198	241	189	444	355	
			c			4.9	3.7	3	2.5	2.5	2.6	1.4	1.6	
			$n_{2 \text{ Eck}}$			88	82	88	88	42	88	33	65	
			$n_{2 \text{ th}}$			88	82	88	88	42	88	33	65	
52.8	400	0.26	M_2	59	74									
			c	5.3	4.3									
			$n_{2 \text{ Eck}}$	77	77									
			$n_{2 \text{ th}}$	77	77									
52.8	592	0.26	M_2			114	155	192	228					
			c			4.1	3.1	2.5	2.1					
			$n_{2 \text{ Eck}}$			77	71	77	77					
			$n_{2 \text{ th}}$			77	71	77	77					
59.481	451	0.25	M_2	66	84									
			c	5.3	4.3									
			$n_{2 \text{ Eck}}$	68	68									
			$n_{2 \text{ th}}$	68	68									
59.481	615	0.25	M_2			129	175	216	257					
			c			3.8	2.9	2.3	1.9					
			$n_{2 \text{ Eck}}$			68	63	68	68					
			$n_{2 \text{ th}}$			68	63	68	68					
64.08	405	0.19	M_2	72	91									
			c	4.4	3.5									
			$n_{2 \text{ Eck}}$	63	63									
			$n_{2 \text{ th}}$	63	63									
64.08	576	0.19	M_2			140	190	234	278					
			c			3.3	2.5	2	1.7					
			$n_{2 \text{ Eck}}$			63	59	63	63					
			$n_{2 \text{ th}}$			63	59	63	63					
72.189	456	0.19	M_2	81	102									
			c	4.9	3.9									
			$n_{2 \text{ Eck}}$	56	56									
			$n_{2 \text{ th}}$	56	56									

$M \dots$ [Nm]
 $n \dots$ [min^{-1}]
 $J \dots$ [kgcm^2]

$P \dots$ [kW]
 $I \dots$ [A]
 $i \dots$ [-]
 $c \dots$ [-]

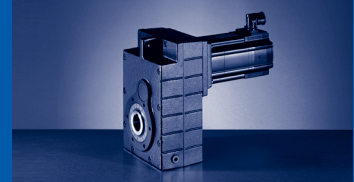

$M_{2GN} \leq 657 \text{ Nm}$

12HC35	12LC20	12LC41	14DC15	14DC36	14HC15	14HC32	14LC15	14LC32	14PC14	14PC32	GFL06-2S			
...S00	...S00	...S00	...S00	...S00	...S00	...S00	...S00	...S00	...S00	...S00	M_1	J_G	M_{2GN}	i
7.5	13.5	11	9.2	7.5	16	14	23	17.2	30	21	n_1			
3525	1950	4050	1500	3600	1500	3225	1500	3225	1350	3225	I_{M230}			
	11.8										I_{M400}			
5.7	5.9	10.2	4.5	7.5	6.6	11.9	9.7	15	10.8	15.6	P_N			
2.8	2.8	4.7	1.45	2.8	2.5	4.7	3.6	5.8	4.2	7.1	J_M			
7.42	10.72	10.72	8.22	8.22	14.32	14.32	23.44	23.44	34.74	34.82	M_2			
266	483	393									c	0.56	611	36.951
1.9	1.3	1.3									$n_{2 \text{ Eck}}$			
95	53	110									$n_{2 \text{ th}}$			
95	53	99									M_2			
											c	0.43	386	40.8
											$n_{2 \text{ Eck}}$			
											$n_{2 \text{ th}}$			
											M_2			
											c	0.43	571	40.8
											$n_{2 \text{ Eck}}$			
											$n_{2 \text{ th}}$			
294	533	434									M_2			
1.9	1.2	1.2									c	0.43	657	40.8
86	48	99									$n_{2 \text{ Eck}}$			
86	48	99									$n_{2 \text{ th}}$			
											M_2			
											c	0.41	435	45.963
											$n_{2 \text{ Eck}}$			
											$n_{2 \text{ th}}$			
333	602	490									M_2			
1.6	1	1									c	0.41	613	45.963
77	42	88									$n_{2 \text{ Eck}}$			
77	42	86									$n_{2 \text{ th}}$			
											M_2			
											c	0.26	400	52.8
											$n_{2 \text{ Eck}}$			
											$n_{2 \text{ th}}$			
											M_2			
											c	0.26	592	52.8
											$n_{2 \text{ Eck}}$			
											$n_{2 \text{ th}}$			
											M_2			
											c	0.25	451	59.481
											$n_{2 \text{ Eck}}$			
											$n_{2 \text{ th}}$			
											M_2			
											c	0.25	615	59.481
											$n_{2 \text{ Eck}}$			
											$n_{2 \text{ th}}$			
											M_2			
											c	0.19	405	64.08
											$n_{2 \text{ Eck}}$			
											$n_{2 \text{ th}}$			
											M_2			
											c	0.19	576	64.08
											$n_{2 \text{ Eck}}$			
											$n_{2 \text{ th}}$			
											M_2			
											c	0.19	456	72.189
											$n_{2 \text{ Eck}}$			
											$n_{2 \text{ th}}$			

$M \dots$ [Nm]
 $n \dots$ [min^{-1}]
 $J \dots$ [kgcm^2]

$P \dots$ [kW]
 $I \dots$ [A]
 i [-]
 c [-]

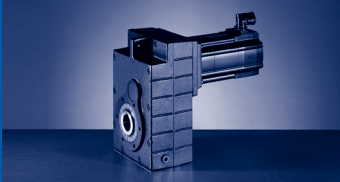

GFL [Nm]

GFL□□-□S (MCS)

$M_{2GN} \leq 657 \text{ Nm}$

GFL06-2S				06FC41	06IC41	09DC41	09FC38	09HC41	09LC41	12DC20	12DC41	12HC15	12HC30
				...500	...500	...500	...500	...500	...500	...500	...500	...500	...500
i	M_{2GN}	J_G	M_1	1.2	1.5	2.3	3.1	3.8	4.5	5.5	4.3	10	8
			n_1	4050	4050	4050	3750	4050	4050	1950	4050	1500	3000
			I_{M230}	2.9	3.2	4.6	5	6.8	8.4	5.2	8.8	7.6	10.5
			I_{M400}	1.5	1.6	2.3	2.5	3.4	4.2	2.6	4.5	3.8	
			P_N	0.51	0.64	1	1.2	1.6	1.9	1.1	1.8	1.6	2.5
			J_M	0.25	0.33	1.13	1.53	1.93	2.83	4.12	4.12	7.42	7.42
72.189	616	0.19	M_2			157	213	263	313				
			c			3.5	2.6	2.1	1.8				
			$n_{2 \text{ Eck}}$			56	52	56	56				
			$n_{2 \text{ th}}$			56	52	56	56				
81	400	0.13	M_2	92	115								
			c	3.8	3.1								
			$n_{2 \text{ Eck}}$	50	50								
			$n_{2 \text{ th}}$	50	50								
91.25	451	0.12	M_2	103	130								
			c	3.8	3.1								
			$n_{2 \text{ Eck}}$	44	44								
			$n_{2 \text{ th}}$	44	44								

$M \dots [\text{Nm}]$
 $n \dots [\text{min}^{-1}]$
 $J \dots [\text{kgcm}^2]$

$P \dots [\text{kW}]$
 $I \dots [\text{A}]$
 $i [-]$
 $c [-]$

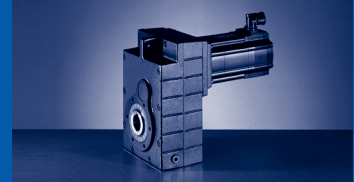

$M_{2GN} \leq 657 \text{ Nm}$

12HC35	12LC20	12LC41	14DC15	14DC36	14HC15	14HC32	14LC15	14LC32	14PC14	14PC32	GFL06-2S			
...S00	...S00	...S00	...S00	...S00	...S00	...S00	...S00	...S00	...S00	...S00	M_1	J_G	M_{2GN}	i
7.5	13.5	11	9.2	7.5	16	14	23	17.2	30	21	n_1			
3525	1950	4050	1500	3600	1500	3225	1500	3225	1350	3225	I_{M230}			
	11.8										I_{M400}			
5.7	5.9	10.2	4.5	7.5	6.6	11.9	9.7	15	10.8	15.6	P_N			
2.8	2.8	4.7	1.45	2.8	2.5	4.7	3.6	5.8	4.2	7.1	J_M			
7.42	10.72	10.72	8.22	8.22	14.32	14.32	23.44	23.44	34.74	34.82	M_2			
											c	0.19	616	72.189
											$n_{2 \text{ Eck}}$			
											$n_{2 \text{ th}}$			
											M_2			
											c	0.13	400	81
											$n_{2 \text{ Eck}}$			
											$n_{2 \text{ th}}$			
											M_2			
											c	0.12	451	91.25
											$n_{2 \text{ Eck}}$			
											$n_{2 \text{ th}}$			

M ... [Nm]
n ... [min^{-1}]
J ... [kgcm^2]

P ... [kW]
I ... [A]
i [-]
c [-]

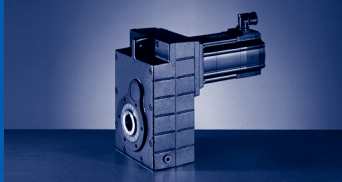

GFL [Nm]

GFL□□-□S (MCS)

$M_{2GN} \leq 634 \text{ Nm}$

GFL06-3S				06CC41	06FC41	06IC41	09DC41	09FC38	09HC41	09LC41
				...500	...500	...500	...500	...500	...500	...500
i	M_{2GN}	J_G	M_1	0.6	1.2	1.5	2.3	3.1	3.8	4.5
			n_1	4050	4050	4050	4050	3750	4050	4050
			I_{M230}	2.6	2.9	3.2	4.6	5	6.8	8.4
			I_{M400}	1.3	1.5	1.6	2.3	2.5	3.4	4.2
			P_N	0.25	0.51	0.64	1	1.2	1.6	1.9
			J_M	0.17	0.25	0.33	1.13	1.53	1.93	2.83
66.213	497	0.29	M_2		72	91	142	193	238	283
			c		5.9	4.7	3.1	2.4	1.9	1.6
			$n_{2 \text{ Eck}}$		61	61	61	57	61	61
			$n_{2 \text{ th}}$		61	61	61	57	61	61
72	497	0.26	M_2		79	100	155	211	260	308
			c		5.4	4.4	2.8	2.2	1.7	1.5
			$n_{2 \text{ Eck}}$		56	56	56	52	56	56
			$n_{2 \text{ th}}$		56	56	56	52	56	56
81.111	497	0.26	M_2		89	113	175	238	293	348
			c		4.8	3.9	2.5	1.9	1.5	1.3
			$n_{2 \text{ Eck}}$		50	50	50	46	50	50
			$n_{2 \text{ th}}$		50	50	50	46	50	50
88.2	488	0.19	M_2		98	123	191	259	319	379
			c		4.4	3.5	2.3	1.7	1.4	1.2
			$n_{2 \text{ Eck}}$		46	46	46	43	46	46
			$n_{2 \text{ th}}$		46	46	46	43	46	46
99.361	550	0.19	M_2		110	139	215	292	359	427
			c		4.4	3.5	2.3	1.7	1.4	1.2
			$n_{2 \text{ Eck}}$		41	41	41	38	41	41
			$n_{2 \text{ th}}$		41	41	41	38	41	41
116.571	528	0.09	M_2		130	164				
			c		3.6	2.9				
			$n_{2 \text{ Eck}}$		35	35				
			$n_{2 \text{ th}}$		35	35				
131.323	595	0.21	M_2		147	185	286	387	476	
			c		3.6	2.9	1.9	1.4	1.1	
			$n_{2 \text{ Eck}}$		31	31	31	29	31	
			$n_{2 \text{ th}}$		31	31	31	29	31	
144.32	560	0.11	M_2		162	204				
			c		3.1	2.5				
			$n_{2 \text{ Eck}}$		28	28				
			$n_{2 \text{ th}}$		28	28				
162.583	613	0.11	M_2	88	183	230				
			c	6	3	2.4				
			$n_{2 \text{ Eck}}$	25	25	25				
			$n_{2 \text{ th}}$	25	25	25				
179.52	605	0.1	M_2	98	202	254				
			c	5.3	2.7	2.1				
			$n_{2 \text{ Eck}}$	23	23	23				
			$n_{2 \text{ th}}$	23	23	23				
202.237	611	0.1	M_2	111	229	287				
			c	4.8	2.4	1.9				
			$n_{2 \text{ Eck}}$	20	20	20				
			$n_{2 \text{ th}}$	20	20	20				
231.2	634	0.07	M_2	128	262	329				
			c	4.3	2.2	1.7				
			$n_{2 \text{ Eck}}$	18	18	18				
			$n_{2 \text{ th}}$	18	18	18				
260.457	613	0.07	M_2	145	296	371				
			c	3.7	1.9	1.5				
			$n_{2 \text{ Eck}}$	16	16	16				
			$n_{2 \text{ th}}$	16	16	16				

$M \dots$ [Nm]
 $n \dots$ [min^{-1}]
 $J \dots$ [kgcm^2]

$P \dots$ [kW]
 $I \dots$ [A]
 i [-]
 c [-]

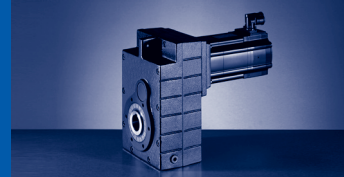

$M_{2GN} \leq 634 \text{ Nm}$

GFL06-3S				06CC41	06FC41	06IC41	09DC41	09FC38	09HC41	09LC41
				...S00	...S00	...S00	...S00	...S00	...S00	...S00
i	M_{2GN}	J_G	M_1	0.6	1.2	1.5	2.3	3.1	3.8	4.5
			n_1	4050	4050	4050	4050	3750	4050	4050
			I_{M230}	2.6	2.9	3.2	4.6	5	6.8	8.4
			I_{M400}	1.3	1.5	1.6	2.3	2.5	3.4	4.2
			P_N	0.25	0.51	0.64	1	1.2	1.6	1.9
			J_M	0.17	0.25	0.33	1.13	1.53	1.93	2.83
299.2	613	0.06	M_2	168	341	428				
			c	3.2	1.6	1.3				
			$n_{2 \text{ Eck}}$	14	14	14				
			$n_{2 \text{ th}}$	14	14	14				

M ... [Nm]
n ... [min^{-1}]
J ... [kgcm^2]

P ... [kW]
I ... [A]
i [-]
c [-]

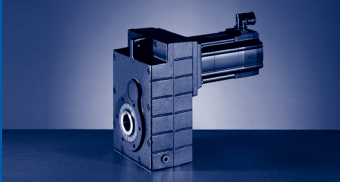

GFL [Nm]

GFL□□-□S (MCS)

$M_{2GN} \leq 1378 \text{ Nm}$

GFL07-2S				09DC41	09FC38	09HC41	09LC41	12DC20	12DC41	12HC15	12HC30	12HC35	12LC20	12LC41	14DC15
				...500	...500	...500	...500	...500	...500	...500	...500	...500	...500	...500	...500
i	M_{2GN}	J_G	M_1	2.3	3.1	3.8	4.5	5.5	4.3	10	8	7.5	13.5	11	9.2
			n_1	4050	3750	4050	4050	1950	4050	1500	3000	3525	1950	4050	1500
			I_{M230}	4.6	5	6.8	8.4	5.2	8.8	7.6	10.5		11.8		
			I_{M400}	2.3	2.5	3.4	4.2	2.6	4.5	3.8		5.7	5.9	10.2	4.5
			P_N	1	1.2	1.6	1.9	1.1	1.8	1.6	2.5	2.8	2.8	4.7	1.45
			J_M	1.13	1.53	1.93	2.83	4.12	4.12	7.42	7.42	7.42	10.72	10.72	8.22
3.35	334	19.57	M_2 c n_2 Eck n_2 th												
3.35	554	19.57	M_2 c n_2 Eck n_2 th												
4.643	410	11.99	M_2 c n_2 Eck n_2 th												
4.643	637	11.99	M_2 c n_2 Eck n_2 th												
5.159	514	11.12	M_2 c n_2 Eck n_2 th												
5.159	850	11.12	M_2 c n_2 Eck n_2 th												
5.695	568	18.09	M_2 c n_2 Eck n_2 th												
5.695	914	18.09	M_2 c n_2 Eck n_2 th												
6.4	296	9.83	M_2 c n_2 Eck n_2 th							60 4.8 234 234	48 4.7 469 457	45 4.8 551 458	82 3.2 305 305	67 3.1 633 420	
6.4	460	9.83	M_2 c n_2 Eck n_2 th												
6.4	662	9.83	M_2 c n_2 Eck n_2 th												
7.15	631	11.88	M_2 c n_2 Eck n_2 th												
7.15	918	11.88	M_2 c n_2 Eck n_2 th												

$M \dots$ [Nm]
 $n \dots$ [min^{-1}]
 $J \dots$ [kgcm^2]

$P \dots$ [kW]
 $I \dots$ [A]
 i [-]
 c [-]

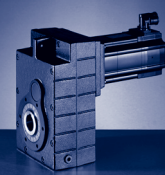

$M_{2GN} \leq 1378 \text{ Nm}$

14DC36	14HC15	14HC32	14LC15	14LC32	14PC14	14PC32	19FC14	19FC30	19JC14	19JC30	19PC14	19PC30	GFL07-2S			
...500	...500	...500	...500	...500	...500	...500	...500	...500	...500	...500	...500	...500	M_1	J_G	M_{2GN}	i
7.5	16	14	23	17.2	30	21	27	21	40	29	51	32	n_1			
3600	1500	3225	1500	3225	1350	3225	1425	3000	1425	3000	1350	3000	I_{M230}			
7.5	6.6	11.9	9.7	15	10.8	15.6	8.6	14	12.3	18.5	14.3	19	I_{M400}			
2.8	2.5	4.7	3.6	5.8	4.2	7.1	4	6.6	6	9.1	7.2	10	P_N			
8.22	14.32	14.32	23.44	23.44	34.74	34.82	65.12	65.04	105.04	105.12	160.12	160.04	J_M			
		43	72	54	95	66							M_2			
		5.7	4.5	4.6	3.4	3.8							c	19.57	334	3.35
		963	448	963	403	963							$n_{2 \text{ Eck}}$			
		671	448	643	403	615							$n_{2 \text{ th}}$			
									126	91	162	101	M_2			
									4.3	4.7	3.3	4.2	c	19.57	554	3.35
									425	896	403	896	$n_{2 \text{ Eck}}$			
									425	644	403	630	$n_{2 \text{ th}}$			
	69	60	100	75	132	92							M_2			
	5.7	5	4	4.1	3	3.4							c	11.99	410	4.643
	323	695	323	695	291	695							$n_{2 \text{ Eck}}$			
	323	543	323	520	291	498							$n_{2 \text{ th}}$			
							116	90	175	127	226	140	M_2			
							5.2	5.3	3.5	3.9	2.8	3.5	c	11.99	637	4.643
							307	646	307	646	291	646	$n_{2 \text{ Eck}}$			
							307	476	307	476	291	476	$n_{2 \text{ th}}$			
		67	111	83	146	102							M_2			
		5.7	4.5	4.6	3.4	3.8							c	11.12	514	5.159
		625	291	625	262	625							$n_{2 \text{ Eck}}$			
		436	291	417	262	399							$n_{2 \text{ th}}$			
									194	140	249	155	M_2			
									4.2	4.7	3.3	4.2	c	11.12	850	5.159
									276	582	262	582	$n_{2 \text{ Eck}}$			
									276	418	262	409	$n_{2 \text{ th}}$			
		74	123	91	162	113							M_2			
		5.7	4.5	4.6	3.4	3.8							c	18.09	568	5.695
		566	263	566	237	566							$n_{2 \text{ Eck}}$			
		395	263	378	237	362							$n_{2 \text{ th}}$			
									214	154	275	171	M_2			
									4.1	4.5	3.2	4.1	c	18.09	914	5.695
									250	527	237	527	$n_{2 \text{ Eck}}$			
									250	376	237	368	$n_{2 \text{ th}}$			
													M_2			
													c	9.83	296	6.4
													$n_{2 \text{ Eck}}$			
													$n_{2 \text{ th}}$			
	96	84	140	104	183	128							M_2			
	4.6	4.1	3.2	3.3	2.5	2.7							c	9.83	460	6.4
	234	504	234	504	211	504							$n_{2 \text{ Eck}}$			
	234	444	234	426	211	408							$n_{2 \text{ th}}$			
							163	126	244	177	313	195	M_2			
							4	4	2.7	2.9	2.1	2.7	c	9.83	662	6.4
							223	469	223	469	211	469	$n_{2 \text{ Eck}}$			
							223	345	223	345	211	345	$n_{2 \text{ th}}$			
	106	93	155	116	204	142							M_2			
	5.7	5	4	4.1	3	3.4							c	11.88	631	7.15
	210	451	210	451	189	451							$n_{2 \text{ Eck}}$			
	210	352	210	338	189	323							$n_{2 \text{ th}}$			
							180	140	271	196	348	217	M_2			
							4.9	5	3.3	3.6	2.6	3.3	c	11.88	918	7.15
							199	420	199	420	189	420	$n_{2 \text{ Eck}}$			
							199	309	199	309	189	309	$n_{2 \text{ th}}$			

$M \dots$ [Nm]
 $n \dots$ [min^{-1}]
 $J \dots$ [kgcm^2]

$P \dots$ [kW]
 $I \dots$ [A]
 $i [-]$
 $c [-]$

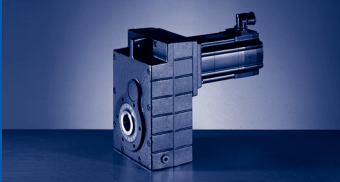

GFL [Nm]

GFL□□-□S (MCS)

$M_{2GN} \leq 1378 \text{ Nm}$

GFL07-2S				09DC41	09FC38	09HC41	09LC41	12DC20	12DC41	12HC15	12HC30	12HC35	12LC20	12LC41	14DC15
				...500	...500	...500	...500	...500	...500	...500	...500	...500	...500	...500	...500
i	M_{2GN}	J_G	M_1	2.3	3.1	3.8	4.5	5.5	4.3	10	8	7.5	13.5	11	9.2
			n_1	4050	3750	4050	4050	1950	4050	1500	3000	3525	1950	4050	1500
			I_{M230}	4.6	5	6.8	8.4	5.2	8.8	7.6	10.5		11.8		
			I_{M400}	2.3	2.5	3.4	4.2	2.6	4.5	3.8		5.7	5.9	10.2	4.5
			P_N	1	1.2	1.6	1.9	1.1	1.8	1.6	2.5	2.8	2.8	4.7	1.45
			J_M	1.13	1.53	1.93	2.83	4.12	4.12	7.42	7.42	7.42	10.72	10.72	8.22
8.324	830	13.11	M_2 c n_2 Eck n_2 th												
8.324	993	13.11	M_2 c n_2 Eck n_2 th												
9.379	935	12.04	M_2 c n_2 Eck n_2 th												
9.379	999	12.04	M_2 c n_2 Eck n_2 th												
9.714	475	8.03	M_2 c n_2 Eck n_2 th							90 5 154 154	72 5 309 293	68 5.1 363 293	124 3.4 201 201	101 3.3 417 268	
9.714	745	8.03	M_2 c n_2 Eck n_2 th												
9.714	969	8.03	M_2 c n_2 Eck n_2 th												
11.538	1018	8.52	M_2 c n_2 Eck n_2 th												
11.538	1080	8.52	M_2 c n_2 Eck n_2 th												
13	1089	7.97	M_2 c n_2 Eck n_2 th												
14.2	694	6.35	M_2 c n_2 Eck n_2 th							132 5 106 106	106 5 211 200	99 5.1 248 201	181 3.4 137 137	148 3.3 285 184	
14.2	1089	6.35	M_2 c n_2 Eck n_2 th												
14.2	1143	6.35	M_2 c n_2 Eck n_2 th												

$M \dots$ [Nm]
 $n \dots$ [min^{-1}]
 $J \dots$ [kgcm^2]

$P \dots$ [kW]
 $I \dots$ [A]
 i [-]
 c [-]

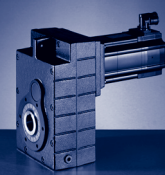

$M_{2GN} \leq 1378 \text{ Nm}$

14DC36	14HC15	14HC32	14LC15	14LC32	14PC14	14PC32	19FC14	19FC30	19JC14	19JC30	19PC14	19PC30	GFL07-2S			
...S00	...S00	...S00	...S00	...S00	...S00	...S00	...S00	...S00	...S00	...S00	...S00	...S00	M_1	J_G	M_{2GN}	i
7.5	16	14	23	17.2	30	21	27	21	40	29	51	32	n_1			
3600	1500	3225	1500	3225	1350	3225	1425	3000	1425	3000	1350	3000	I_{M230}			
7.5	6.6	11.9	9.7	15	10.8	15.6	8.6	14	12.3	18.5	14.3	19	I_{M400}			
2.8	2.5	4.7	3.6	5.8	4.2	7.1	4	6.6	6	9.1	7.2	10	P_N			
8.22	14.32	14.32	23.44	23.44	34.74	34.82	65.12	65.04	105.04	105.12	160.12	160.04	J_M			
		108	179	134	236	165							M_2			
		5.7	4.5	4.6	3.4	3.8							c	13.11	830	8.324
		387	180	387	162	387							$n_2 \text{ Eck}$			
		270	180	259	162	247							$n_2 \text{ th}$			
							210	163	316	229	406	253	M_2			
							4.6	4.7	3.1	3.4	2.4	3.1	c	13.11	993	8.324
							171	360	171	360	162	360	$n_2 \text{ Eck}$			
							171	259	171	241	162	235	$n_2 \text{ th}$			
		121	202	151	266	186							M_2			
		5.7	4.5	4.6	3.4	3.8							c	12.04	935	9.379
		344	160	344	144	344							$n_2 \text{ Eck}$			
		240	160	229	144	219							$n_2 \text{ th}$			
							238	185	357	258	459	286	M_2			
							4.1	4.2	2.8	3	2.2	2.7	c	12.04	999	9.379
							152	320	152	320	144	320	$n_2 \text{ Eck}$			
							152	224	152	208	144	203	$n_2 \text{ th}$			
													M_2			
													c	8.03	475	9.714
													$n_2 \text{ Eck}$			
													$n_2 \text{ th}$			
	145	127	211	158	278	194							M_2			
	4.9	4.4	3.4	3.6	2.6	2.9							c	8.03	745	9.714
	154	332	154	332	139	332							$n_2 \text{ Eck}$			
	154	285	154	273	139	261							$n_2 \text{ th}$			
							247	192	371	268	476	297	M_2			
							3.8	3.9	2.6	2.8	2	2.6	c	8.03	969	9.714
							147	309	147	309	139	309	$n_2 \text{ Eck}$			
							147	228	147	228	139	228	$n_2 \text{ th}$			
	170	150	250	186	329	229							M_2			
	5.7	5	4	4.1	3	3.4							c	8.52	1018	11.538
	130	280	130	280	117	280							$n_2 \text{ Eck}$			
	130	218	130	209	117	200							$n_2 \text{ th}$			
							294	229	441	319	566	353	M_2			
							3.6	3.7	2.4	2.6	1.9	2.4	c	8.52	1080	11.538
							124	260	124	260	117	260	$n_2 \text{ Eck}$			
							124	192	124	190	117	186	$n_2 \text{ th}$			
	193	170	282	210	371	259	333	259	498	361	639	399	M_2			
	5.4	4.8	3.8	3.9	2.9	3.2	3.2	3.3	2.2	2.4	1.7	2.1	c	7.97	1089	13
	115	248	115	248	104	248	110	231	110	231	104	231	$n_2 \text{ Eck}$			
	115	192	115	184	104	176	110	170	110	164	104	160	$n_2 \text{ th}$			
													M_2			
													c	6.35	694	14.2
													$n_2 \text{ Eck}$			
													$n_2 \text{ th}$			
	211	186	309	231	406	284							M_2			
	4.9	4.4	3.4	3.6	2.6	2.9							c	6.35	1089	14.2
	106	227	106	227	95	227							$n_2 \text{ Eck}$			
	106	195	106	187	95	179							$n_2 \text{ th}$			
							364	283	545	394	698	436	M_2			
							3.1	3.1	2.1	2.3	1.6	2.1	c	6.35	1143	14.2
							100	211	100	211	95	211	$n_2 \text{ Eck}$			
							100	156	100	156	95	156	$n_2 \text{ th}$			

M ... [Nm]
n ... [min⁻¹]
J ... [kgcm²]

P ... [kW]
I ... [A]
i [-]
c [-]

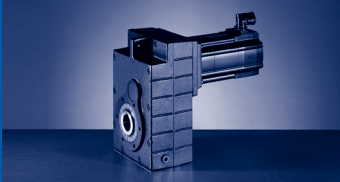

GFL [Nm]

GFL□□-□S (MCS)

$M_{2GN} \leq 1378 \text{ Nm}$

GFL07-2S				09DC41	09FC38	09HC41	09LC41	12DC20	12DC41	12HC15	12HC30	12HC35	12LC20	12LC41	14DC15
				...500	...500	...500	...500	...500	...500	...500	...500	...500	...500	...500	...500
i	M_{2GN}	J_G	M_1	2.3	3.1	3.8	4.5	5.5	4.3	10	8	7.5	13.5	11	9.2
			n_1	4050	3750	4050	4050	1950	4050	1500	3000	3525	1950	4050	1500
			I_{M230}	4.6	5	6.8	8.4	5.2	8.8	7.6	10.5		11.8		
			I_{M400}	2.3	2.5	3.4	4.2	2.6	4.5	3.8		5.7	5.9	10.2	4.5
			P_N	1	1.2	1.6	1.9	1.1	1.8	1.6	2.5	2.8	2.8	4.7	1.45
			J_M	1.13	1.53	1.93	2.83	4.12	4.12	7.42	7.42	7.42	10.72	10.72	8.22
15.904	735	5.27	M_2							148	119	111	204	166	
			c							4.8	4.7	4.8	3.2	3.1	
			$n_{2 \text{ Eck}}$							94	189	222	123	255	
			$n_{2 \text{ th}}$							94	184	184	123	169	
15.904	1143	5.27	M_2												
			c												
			$n_{2 \text{ Eck}}$												
			$n_{2 \text{ th}}$												
15.904	1179	5.27	M_2												
			c												
			$n_{2 \text{ Eck}}$												
			$n_{2 \text{ th}}$												
17.92	829	4.98	M_2							167	134	125	229	187	
			c							4.8	4.7	4.8	3.2	3.1	
			$n_{2 \text{ Eck}}$							84	167	197	109	226	
			$n_{2 \text{ th}}$							84	163	164	109	150	
17.92	1189	4.98	M_2												
			c												
			$n_{2 \text{ Eck}}$												
			$n_{2 \text{ th}}$												
20.286	614	3.47	M_2			71	85								
			c			5.9	5								
			$n_{2 \text{ Eck}}$			200	200								
			$n_{2 \text{ th}}$			175	170								
20.286	789	3.47	M_2							191	153	143	261	213	
			c							4	4	4	2.7	2.6	
			$n_{2 \text{ Eck}}$							74	148	174	96	200	
			$n_{2 \text{ th}}$							74	148	163	96	150	
20.286	1092	3.47	M_2												
			c												
			$n_{2 \text{ Eck}}$												
			$n_{2 \text{ th}}$												
22.857	691	3.27	M_2			80	96								
			c			5.9	5								
			$n_{2 \text{ Eck}}$			177	177								
			$n_{2 \text{ th}}$			155	151								
22.857	890	3.27	M_2							215	172	161	294	240	
			c							4	4	4	2.7	2.6	
			$n_{2 \text{ Eck}}$							66	131	154	85	177	
			$n_{2 \text{ th}}$							66	131	145	85	133	
22.857	1231	3.27	M_2												
			c												
			$n_{2 \text{ Eck}}$												
			$n_{2 \text{ th}}$												
24.85	831	2.65	M_2							235	187	175	320	261	
			c							3.5	3.9	3.9	2.6	2.6	
			$n_{2 \text{ Eck}}$							60	121	142	79	163	
			$n_{2 \text{ th}}$							60	121	142	78	133	
24.85	1289	2.65	M_2												211
			c												5.8
			$n_{2 \text{ Eck}}$												60
			$n_{2 \text{ th}}$												60

$M \dots$ [Nm]
 $n \dots$ [min^{-1}]
 $J \dots$ [kgcm^2]

$P \dots$ [kW]
 $I \dots$ [A]
 $i \dots$ [-]
 $c \dots$ [-]

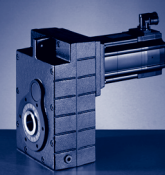

$M_{2GN} \leq 1378 \text{ Nm}$

14DC36	14HC15	14HC32	14LC15	14LC32	14PC14	14PC32	19FC14	19FC30	19JC14	19JC30	19PC14	19PC30	GFL07-2S			
...S00	...S00	...S00	...S00	...S00	...S00	...S00	...S00	...S00	...S00	...S00	...S00	...S00	M_1	J_G	M_{2GN}	i
7.5	16	14	23	17.2	30	21	27	21	40	29	51	32	n_1			
3600	1500	3225	1500	3225	1350	3225	1425	3000	1425	3000	1350	3000	l_{M230}			
7.5	6.6	11.9	9.7	15	10.8	15.6	8.6	14	12.3	18.5	14.3	19	l_{M400}			
2.8	2.5	4.7	3.6	5.8	4.2	7.1	4	6.6	6	9.1	7.2	10	P_N			
8.22	14.32	14.32	23.44	23.44	34.74	34.82	65.12	65.04	105.04	105.12	160.12	160.04	J_M			
													M_2 c			
													n_2 Eck	5.27	735	15.904
													n_2 th			
	238	209	347	259	456	318							M_2 c			
	4.6	4.1	3.2	3.3	2.5	2.7							n_2 Eck	5.27	1143	15.904
	94	203	94	203	85	203							n_2 th			
	94	179	94	171	85	164										
							409	318	611	442	783	489	M_2 c			
							2.8	2.9	1.9	2.1	1.5	1.9	n_2 Eck	5.27	1179	15.904
							90	189	90	189	85	189	n_2 th			
							90	139	90	139	85	139				
													M_2 c			
													n_2 Eck	4.98	829	17.92
													n_2 th			
	269	236	392	293	515	359	462	359	690	500	884	552	M_2 c			
	4.3	3.8	3	3.1	2.3	2.5	2.5	2.6	1.7	1.9	1.3	1.7	n_2 Eck	4.98	1189	17.92
	84	180	84	180	75	180	80	167	80	167	75	167	n_2 th			
	84	156	84	150	75	143	80	123	80	123	75	123				
													M_2 c			
													n_2 Eck	3.47	614	20.286
													n_2 th			
													M_2 c			
													n_2 Eck	3.47	789	20.286
													n_2 th			
141	307	270	446	333	585	409							M_2 c			
5.5	3.5	3.1	2.4	2.5	1.9	2.1							n_2 Eck	3.47	1092	20.286
178	74	159	74	159	67	159							n_2 th			
173	74	155	74	148	67	142										
													M_2 c			
													n_2 Eck	3.27	691	22.857
													n_2 th			
													M_2 c			
													n_2 Eck	3.27	890	22.857
													n_2 th			
159	346	304	503	376	659	461							M_2 c			
5.5	3.5	3.1	2.4	2.5	1.9	2.1							n_2 Eck	3.27	1231	22.857
158	66	141	66	141	59	141							n_2 th			
154	66	137	66	131	59	126										
													M_2 c			
													n_2 Eck	2.65	831	24.85
													n_2 th			
	376	329	547	407	717	500							M_2 c			
	3.3	3.4	2.3	2.7	1.8	2.2							n_2 Eck	2.65	1289	24.85
	60	130	60	130	54	130							n_2 th			
	60	130	60	130	54	130										

$M \dots$ [Nm]
 $n \dots$ [min^{-1}]
 $J \dots$ [kgcm^2]

$P \dots$ [kW]
 $I \dots$ [A]
 i [-]
 c [-]

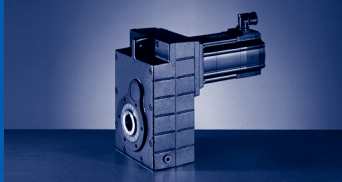

GFL [Nm]

GFL□□-□S (MCS)

$M_{2GN} \leq 1378 \text{ Nm}$

GFL07-2S				09DC41	09FC38	09HC41	09LC41	12DC20	12DC41	12HC15	12HC30	12HC35	12LC20	12LC41	14DC15		
				...500	...500	...500	...500	...500	...500	...500	...500	...500	...500	...500	...500		
i	M_{2GN}	J_G	M_1	2.3	3.1	3.8	4.5	5.5	4.3	10	8	7.5	13.5	11	9.2		
			n_1	4050	3750	4050	4050	1950	4050	1500	3000	3525	1950	4050	1500		
			I_{M230}	4.6	5	6.8	8.4	5.2	8.8	7.6	10.5		11.8				
			I_{M400}	2.3	2.5	3.4	4.2	2.6	4.5	3.8		5.7	5.9	10.2	4.5		
			P_N	1	1.2	1.6	1.9	1.1	1.8	1.6	2.5	2.8	2.8	4.7	1.45		
			J_M	1.13	1.53	1.93	2.83	4.12	4.12	7.42	7.42	7.42	10.72	10.72	8.22		
28	936	2.53	M_2							265	211	198	361	294			
			c								3.5	3.9	3.9	2.6	2.6		
			$n_{2 \text{ Eck}}$									54	107	126	70	145	
			$n_{2 \text{ th}}$									54	107	126	70	118	
28	1242	2.53	M_2												240		
			c													5	
			$n_{2 \text{ Eck}}$														54
			$n_{2 \text{ th}}$														54
32.344	674	1.69	M_2		92	115	137										
			c		5.8	4.6	3.9										
			$n_{2 \text{ Eck}}$		116	125	125										
			$n_{2 \text{ th}}$		116	125	125										
32.344	868	1.69	M_2					165	129	308	246	230	419	341			
			c					5	5.3	2.8	3.1	3.2	2.1	2.1			
			$n_{2 \text{ Eck}}$					60	125	46	93	109	60	125			
			$n_{2 \text{ th}}$					60	125	46	93	109	60	120			
32.344	1346	1.69	M_2												278		
			c													4.7	
			$n_{2 \text{ Eck}}$														46
			$n_{2 \text{ th}}$														46
36.444	760	1.61	M_2		104	129	154										
			c		5.8	4.6	3.9										
			$n_{2 \text{ Eck}}$		103	111	111										
			$n_{2 \text{ th}}$		103	111	111										
36.444	978	1.61	M_2					186	145	347	277	259	472	385			
			c					5	5.3	2.8	3.1	3.2	2.1	2.1			
			$n_{2 \text{ Eck}}$					54	111	41	82	97	54	111			
			$n_{2 \text{ th}}$					54	111	41	82	97	54	106			
36.444	1248	1.61	M_2												316		
			c													3.8	
			$n_{2 \text{ Eck}}$														41
			$n_{2 \text{ th}}$														41
39.642	707	1.25	M_2		114	142	169										
			c		5	4	3.3										
			$n_{2 \text{ Eck}}$		95	102	102										
			$n_{2 \text{ th}}$		95	102	102										
39.642	910	1.25	M_2					204	159	379	302	283	515	420			
			c					4.3	4.5	2.4	2.7	2.7	1.8	1.8			
			$n_{2 \text{ Eck}}$					49	102	38	76	89	49	102			
			$n_{2 \text{ th}}$					49	102	38	76	89	49	102			
39.642	1378	1.25	M_2												343		
			c													3.9	
			$n_{2 \text{ Eck}}$														38
			$n_{2 \text{ th}}$														38
44.667	797	1.2	M_2		129	160	190										
			c		5	4	3.3										
			$n_{2 \text{ Eck}}$		84	91	91										
			$n_{2 \text{ th}}$		84	91	91										
44.667	1025	1.2	M_2					230	180	427	341	319	581	473			
			c					4.3	4.5	2.4	2.7	2.7	1.8	1.8			
			$n_{2 \text{ Eck}}$					44	91	34	67	79	44	91			
			$n_{2 \text{ th}}$					44	91	34	67	79	44	91			

$M \dots$ [Nm]
 $n \dots$ [min^{-1}]
 $J \dots$ [kgcm^2]

$P \dots$ [kW]
 $I \dots$ [A]
 $i \dots$ [-]
 $c \dots$ [-]

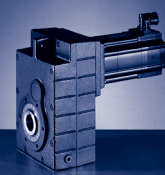

$M_{2GN} \leq 1378 \text{ Nm}$

14DC36	14HC15	14HC32	14LC15	14LC32	14PC14	14PC32	19FC14	19FC30	19JC14	19JC30	19PC14	19PC30	GFL07-2S			
...S00	...S00	...S00	...S00	...S00	...S00	...S00	...S00	...S00	...S00	...S00	...S00	...S00	M_1	J_G	M_{2GN}	i
7.5	16	14	23	17.2	30	21	27	21	40	29	51	32	n_1			
3600	1500	3225	1500	3225	1350	3225	1425	3000	1425	3000	1350	3000	l_{M230}			
7.5	6.6	11.9	9.7	15	10.8	15.6	8.6	14	12.3	18.5	14.3	19	l_{M400}			
2.8	2.5	4.7	3.6	5.8	4.2	7.1	4	6.6	6	9.1	7.2	10	P_N			
8.22	14.32	14.32	23.44	23.44	34.74	34.82	65.12	65.04	105.04	105.12	160.12	160.04	J_M			
													M_2 c	2.53	936	28
													n_2 Eck			
													n_2 th			
195	426	373	618	461	811	565							M_2 c	2.53	1242	28
5.2	2.9	2.9	2	2.3	1.5	1.9							n_2 Eck			
129	54	115	54	115	48	115							n_2 th			
128	54	115	54	115	48	111							M_2 c	1.69	674	32.344
													n_2 Eck			
													n_2 th			
													M_2 c	1.69	868	32.344
													n_2 Eck			
													n_2 th			
226	493	432	715	533	937	654							M_2 c	1.69	1346	32.344
4.9	2.7	2.7	1.9	2.2	1.4	1.8							n_2 Eck			
111	46	100	46	100	42	100							n_2 th			
111	46	100	46	100	42	100							M_2 c	1.61	760	36.444
													n_2 Eck			
													n_2 th			
													M_2 c	1.61	978	36.444
													n_2 Eck			
													n_2 th			
257	559	489	809	603	1059	739							M_2 c	1.61	1248	36.444
4	2.2	2.2	1.5	1.8	1.2	1.5							n_2 Eck			
99	41	89	41	89	37	89							n_2 th			
99	41	88	41	88	37	88							M_2 c	1.25	707	39.642
													n_2 Eck			
													n_2 th			
													M_2 c	1.25	910	39.642
													n_2 Eck			
													n_2 th			
279	608	532	880	656	1152	804							M_2 c	1.25	1378	39.642
4.1	2.2	2.3	1.6	1.8	1.2	1.5							n_2 Eck			
91	38	81	38	81	34	81							n_2 th			
91	38	81	38	81	34	81							M_2 c	1.2	797	44.667
													n_2 Eck			
													n_2 th			
													M_2 c	1.2	1025	44.667
													n_2 Eck			
													n_2 th			

$M \dots$ [Nm]
 $n \dots$ [min^{-1}]
 $J \dots$ [kgcm^2]

$P \dots$ [kW]
 $I \dots$ [A]
 i [-]
 c [-]

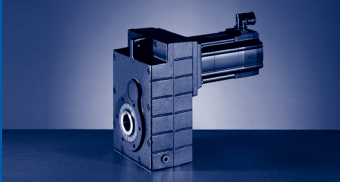

GFL [Nm]

GFL□□-□S (MCS)

$M_{2GN} \leq 1378 \text{ Nm}$

GFL07-2S				09DC41	09FC38	09HC41	09LC41	12DC20	12DC41	12HC15	12HC30	12HC35	12LC20	12LC41	14DC15			
				...S00	...S00	...S00	...S00	...S00	...S00	...S00	...S00	...S00	...S00	...S00	...S00			
i	M_{2GN}	J_G	M_1	2.3	3.1	3.8	4.5	5.5	4.3	10	8	7.5	13.5	11	9.2			
			n_1	4050	3750	4050	4050	1950	4050	1500	3000	3525	1950	4050	1500			
			I_{M230}	4.6	5	6.8	8.4	5.2	8.8	7.6	10.5		11.8					
			I_{M400}	2.3	2.5	3.4	4.2	2.6	4.5	3.8		5.7	5.9	10.2	4.5			
			P_N	1	1.2	1.6	1.9	1.1	1.8	1.6	2.5	2.8	2.8	4.7	1.45			
			J_M	1.13	1.53	1.93	2.83	4.12	4.12	7.42	7.42	7.42	10.72	10.72	8.22			
44.667	1258	1.2	M_2													390		
			c														3.2	
			n_2 Eck															34
			n_2 th															34
52.067	726	0.78	M_2	111	152	188	224											
			c	5.1	3.9	3.1	2.6											
			n_2 Eck	78	72	78	78											
			n_2 th	78	72	78	78											
52.067	935	0.78	M_2					271	212	501	400	375	679	554				
			c					3.4	3.5	1.9	2.1	2.1	1.4	1.4				
			n_2 Eck					38	78	29	58	68	38	78				
			n_2 th					37	78	29	58	68	37	78				
58.667	819	0.75	M_2	125	171	212	252											
			c	5.1	3.9	3.1	2.6											
			n_2 Eck	69	64	69	69											
			n_2 th	69	64	69	69											
58.667	1054	0.75	M_2					305	238	564	450	422	765	624				
			c					3.4	3.5	1.9	2.1	2.1	1.4	1.4				
			n_2 Eck					33	69	26	51	60	33	69				
			n_2 th					33	69	26	51	60	33	69				
63.19	735	0.57	M_2	136	186	229	273											
			c	4.3	3.2	2.6	2.2											
			n_2 Eck	64	59	64	64											
			n_2 th	64	59	64	64											
63.19	946	0.57	M_2					331	258	610	487	456	826	673				
			c					2.8	2.9	1.5	1.7	1.8	1.1	1.2				
			n_2 Eck					31	64	24	48	56	31	64				
			n_2 th					31	64	24	47	56	31	64				
71.2	828	0.56	M_2	153	208	257	306											
			c	4.7	3.6	2.9	2.4											
			n_2 Eck	57	53	57	57											
			n_2 th	57	53	57	57											
71.2	1066	0.56	M_2					373	290	687	547	513	931	758				
			c					2.8	3.3	1.5	1.9	2	1.1	1.3				
			n_2 Eck					27	57	21	42	50	27	57				
			n_2 th					27	57	21	42	50	27	57				
79.875	744	0.37	M_2	173	236	291	345											
			c	3.8	2.9	2.3	1.9											
			n_2 Eck	51	47	51	51											
			n_2 th	51	47	51	51											
90	839	0.36	M_2	195	265	327	389											
			c	3.8	2.9	2.3	1.9											
			n_2 Eck	45	42	45	45											
			n_2 th	45	42	45	45											

$M \dots$ [Nm]
 $n \dots$ [min^{-1}]
 $J \dots$ [kgcm^2]

$P \dots$ [kW]
 $I \dots$ [A]
 i [-]
 c [-]

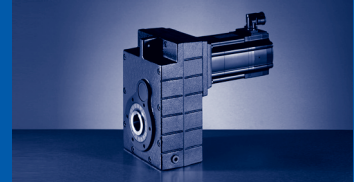

$M_{2GN} \leq 1378 \text{ Nm}$

14DC36	14HC15	14HC32	14LC15	14LC32	14PC14	14PC32	19FC14	19FC30	19JC14	19JC30	19PC14	19PC30	GFL07-2S			
...S00	...S00	...S00	...S00	...S00	...S00	...S00	...S00	...S00	...S00	...S00	...S00	...S00	M_1	J_G	M_{2GN}	i
7.5	16	14	23	17.2	30	21	27	21	40	29	51	32	n_1			
3600	1500	3225	1500	3225	1350	3225	1425	3000	1425	3000	1350	3000	I_{M230}			
7.5	6.6	11.9	9.7	15	10.8	15.6	8.6	14	12.3	18.5	14.3	19	I_{M400}			
2.8	2.5	4.7	3.6	5.8	4.2	7.1	4	6.6	6	9.1	7.2	10	P_N			
8.22	14.32	14.32	23.44	23.44	34.74	34.82	65.12	65.04	105.04	105.12	160.12	160.04	J_M			
317	688	602	994	742		908							M_2			
3.3	1.8	1.8	1.3	1.5		1.2							c	1.2	1258	44.667
81	34	72	34	72		72							$n_2 \text{ Eck}$			
80	34	72	34	72		72							$n_2 \text{ th}$			
													M_2			
													c	0.78	726	52.067
													$n_2 \text{ Eck}$			
													$n_2 \text{ th}$			
													M_2			
													c	0.78	935	52.067
													$n_2 \text{ Eck}$			
													$n_2 \text{ th}$			
													M_2			
													c	0.75	819	58.667
													$n_2 \text{ Eck}$			
													$n_2 \text{ th}$			
													M_2			
													c	0.75	1054	58.667
													$n_2 \text{ Eck}$			
													$n_2 \text{ th}$			
													M_2			
													c	0.57	735	63.19
													$n_2 \text{ Eck}$			
													$n_2 \text{ th}$			
													M_2			
													c	0.57	946	63.19
													$n_2 \text{ Eck}$			
													$n_2 \text{ th}$			
													M_2			
													c	0.56	828	71.2
													$n_2 \text{ Eck}$			
													$n_2 \text{ th}$			
													M_2			
													c	0.56	1066	71.2
													$n_2 \text{ Eck}$			
													$n_2 \text{ th}$			
													M_2			
													c	0.37	744	79.875
													$n_2 \text{ Eck}$			
													$n_2 \text{ th}$			
													M_2			
													c	0.36	839	90
													$n_2 \text{ Eck}$			
													$n_2 \text{ th}$			

M ... [Nm]
n ... [min⁻¹]
J ... [kgcm²]

P ... [kW]
I ... [A]
i [-]
c [-]

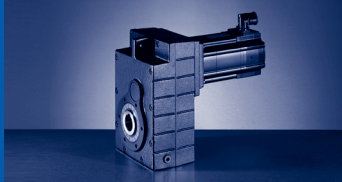

GFL [Nm]

GFL□□-□S (MCS)

$M_{2GN} \leq 1378 \text{ Nm}$

GFL07-3S				06CC41	06FC41	06IC41	09DC41	09FC38	09HC41	09LC41
				...S00	...S00	...S00	...S00	...S00	...S00	...S00
i	M_{2GN}	J_G	M_1	0.6	1.2	1.5	2.3	3.1	3.8	4.5
			n_1	4050	4050	4050	4050	3750	4050	4050
			I_{M230}	2.6	2.9	3.2	4.6	5	6.8	8.4
			I_{M400}	1.3	1.5	1.6	2.3	2.5	3.4	4.2
			P_N	0.25	0.51	0.64	1	1.2	1.6	1.9
			J_M	0.17	0.25	0.33	1.13	1.53	1.93	2.83
65.306	883	0.79	M_2				137	187	231	275
			c				5.6	4.2	3.4	2.8
			n_2 Eck				62	57	62	62
			n_2 th				62	57	62	62
72.452	869	0.89	M_2				153	208	258	307
			c				4.9	3.8	3	2.5
			n_2 Eck				56	52	56	56
			n_2 th				56	52	56	56
81.636	979	0.88	M_2				172	235	290	345
			c				4.9	3.8	3	2.5
			n_2 Eck				50	46	50	50
			n_2 th				50	46	50	50
92.413	961	0.61	M_2				196	267	330	392
			c				4.3	3.3	2.6	2.2
			n_2 Eck				44	41	44	44
			n_2 th				44	41	44	44
104.127	1082	0.6	M_2				221	301	372	442
			c				4.3	3.3	2.6	2.2
			n_2 Eck				39	36	39	39
			n_2 th				39	36	39	39
113.206	1040	0.45	M_2			154	242	329	406	482
			c			5.8	3.8	2.9	2.3	1.9
			n_2 Eck			36	36	33	36	36
			n_2 th			36	36	33	36	36
127.556	1171	0.44	M_2			174	272	370	457	543
			c			5.8	3.8	2.9	2.3	1.9
			n_2 Eck			32	32	29	32	32
			n_2 th			32	32	29	32	32
147.347	1140	0.28	M_2			203	316	430	530	630
			c			4.9	3.2	2.4	1.9	1.6
			n_2 Eck			28	28	26	28	28
			n_2 th			27	27	25	27	27
166.025	1248	0.27	M_2		181	229	357	485	597	710
			c		5.9	4.8	3.1	2.4	1.9	1.6
			n_2 Eck		24	24	24	23	24	24
			n_2 th		24	24	24	23	24	24
183.285	1236	0.19	M_2		201	254	395	537	661	785
			c		5.3	4.3	2.8	2.1	1.7	1.4
			n_2 Eck		22	22	22	21	22	22
			n_2 th		22	22	22	20	22	22
206.519	1248	0.19	M_2		227	287	447	606	746	886
			c		4.8	3.8	2.5	1.9	1.5	1.3
			n_2 Eck		20	20	20	18	20	20
			n_2 th		20	20	20	18	20	20
224.636	1343	0.18	M_2		248	313	486	659	812	963
			c		4.7	3.8	2.5	1.9	1.5	1.3
			n_2 Eck		18	18	18	17	18	18
			n_2 th		18	18	18	17	18	18
253.111	1258	0.18	M_2		281	355	550	745	917	1088
			c		3.9	3.1	2.1	1.6	1.2	1.1
			n_2 Eck		16	16	16	15	16	16
			n_2 th		16	16	16	15	16	16

$M \dots$ [Nm]
 $n \dots$ [min^{-1}]
 $J \dots$ [kgcm^2]

$P \dots$ [kW]
 $I \dots$ [A]
 i [-]
 c [-]

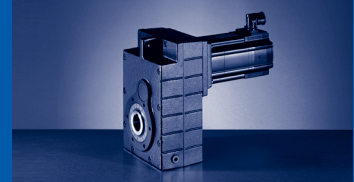

$M_{2GN} \leq 1378 \text{ Nm}$

12DC20	12DC41	12HC15	12HC30	12HC35	12LC20	12LC41	GFL07-3S			
...500	...500	...500	...500	...500	...500	...500				
5.5	4.3	10	8	7.5	13.5	11	M_1	J_G	M_{2GN}	i
1950	4050	1500	3000	3525	1950	4050	n_1			
5.2	8.8	7.6	10.5		11.8		I_{M230}			
2.6	4.5	3.8		5.7	5.9	10.2	I_{M400}			
1.1	1.8	1.6	2.5	2.8	2.8	4.7	P_N			
4.12	4.12	7.42	7.42	7.42	10.72	10.72	J_M			
338	263	621	495	464	842	685	M_2			
2.6	3	1.4	1.8	1.8	1.1	1.2	c	0.79	883	65.306
30	62	23	46	54	30	62	$n_{2 \text{ Eck}}$			
30	62	23	46	54	30	62	$n_{2 \text{ th}}$			
376	293	691	551	516		761	M_2			
2.3	2.6	1.3	1.6	1.6		1	c	0.89	869	72.452
27	56	21	41	49		56	$n_{2 \text{ Eck}}$			
27	56	21	41	49		46	$n_{2 \text{ th}}$			
423	330	778	620	582		858	M_2			
2.3	2.6	1.3	1.6	1.6		1	c	0.88	979	81.636
24	50	18	37	43		50	$n_{2 \text{ Eck}}$			
24	50	18	37	43		41	$n_{2 \text{ th}}$			
481	375	882	704	660			M_2			
2	2.3	1.1	1.4	1.4			c	0.61	961	92.413
21	44	16	33	38			$n_{2 \text{ Eck}}$			
21	44	16	32	38			$n_{2 \text{ th}}$			
542	422	994	793	743			M_2			
2	2.3	1.1	1.4	1.4			c	0.6	1082	104.127
19	39	14	29	34			$n_{2 \text{ Eck}}$			
19	39	14	29	34			$n_{2 \text{ th}}$			
590	460		864	810			M_2			
1.8	2		1.2	1.2			c	0.45	1040	113.206
17	36		27	31			$n_{2 \text{ Eck}}$			
17	36		27	31			$n_{2 \text{ th}}$			
665	519		973	912			M_2			
1.8	2		1.2	1.2			c	0.44	1171	127.556
15	32		24	28			$n_{2 \text{ Eck}}$			
15	32		24	28			$n_{2 \text{ th}}$			
							M_2			
							c	0.28	1140	147.347
							$n_{2 \text{ Eck}}$			
							$n_{2 \text{ th}}$			
							M_2			
							c	0.27	1248	166.025
							$n_{2 \text{ Eck}}$			
							$n_{2 \text{ th}}$			
							M_2			
							c	0.19	1236	183.285
							$n_{2 \text{ Eck}}$			
							$n_{2 \text{ th}}$			
							M_2			
							c	0.19	1248	206.519
							$n_{2 \text{ Eck}}$			
							$n_{2 \text{ th}}$			
							M_2			
							c	0.18	1343	224.636
							$n_{2 \text{ Eck}}$			
							$n_{2 \text{ th}}$			
							M_2			
							c	0.18	1258	253.111
							$n_{2 \text{ Eck}}$			
							$n_{2 \text{ th}}$			

M ... [Nm]
n ... [min^{-1}]
J ... [kgcm^2]

P ... [kW]
I ... [A]
i [-]
c [-]

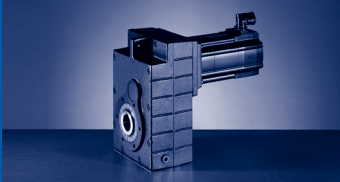

GFL [Nm]

GFL□□-□S (MCS)

$M_{2GN} \leq 1378 \text{ Nm}$

GFL07-3S				06CC41	06FC41	06IC41	09DC41	09FC38	09HC41	09LC41
				...500	...500	...500	...500	...500	...500	...500
i	M_{2GN}	J_G	M_1	0.6	1.2	1.5	2.3	3.1	3.8	4.5
			n_1	4050	4050	4050	4050	3750	4050	4050
			I_{M230}	2.6	2.9	3.2	4.6	5	6.8	8.4
			I_{M400}	1.3	1.5	1.6	2.3	2.5	3.4	4.2
			P_N	0.25	0.51	0.64	1	1.2	1.6	1.9
			J_M	0.17	0.25	0.33	1.13	1.53	1.93	2.83
290.706	1378	0.11	M_2		324	408				
			c		3.7	3				
			n_2 Eck		14	14				
			n_2 th		14	14				
327.556	1258	0.11	M_2		368	463				
			c		3	2.4				
			n_2 Eck		12	12				
			n_2 th		12	12				
352.811	1378	0.08	M_2		396	498				
			c		3.1	2.5				
			n_2 Eck		12	12				
			n_2 th		11	11				
397.533	1258	0.08	M_2	218	449	564				
			c	5	2.5	2				
			n_2 Eck	10	10	10				
			n_2 th	10	10	10				
430.222	1270	0.1	M_2	237	487	611				
			c	4.7	2.3	1.9				
			n_2 Eck	9	9	9				
			n_2 th	9	9	9				
522.133	1270	0.08	M_2	291	593	744				
			c	3.8	1.9	1.5				
			n_2 Eck	8	8	8				
			n_2 th	8	8	8				
562.391	1128	0.07	M_2	315	641	804				
			c	3.2	1.6	1.3				
			n_2 Eck	7	7	7				
			n_2 th	7	7	7				
633.68	1220	0.07	M_2	356	723	906				
			c	3	1.5	1.2				
			n_2 Eck	6	6	6				
			n_2 th	6	6	6				

$M \dots$ [Nm]
 $n \dots$ [min^{-1}]
 $J \dots$ [kgcm^2]

$P \dots$ [kW]
 $I \dots$ [A]
 $i \dots$ [-]
 $c \dots$ [-]

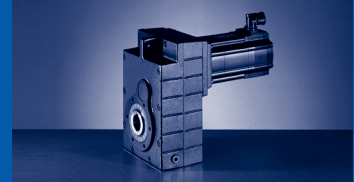

$M_{2GN} \leq 1378 \text{ Nm}$

12DC20	12DC41	12HC15	12HC30	12HC35	12LC20	12LC41	GFL07-3S			
...500	...500	...500	...500	...500	...500	...500	M_1	J_G	M_{2GN}	i
5.5	4.3	10	8	7.5	13.5	11	n_1			
1950	4050	1500	3000	3525	1950	4050	I_{M230}			
5.2	8.8	7.6	10.5		11.8		I_{M400}			
2.6	4.5	3.8		5.7	5.9	10.2	P_N			
1.1	1.8	1.6	2.5	2.8	2.8	4.7	J_M			
4.12	4.12	7.42	7.42	7.42	10.72	10.72	M_2 c n_2 Eck n_2 th	0.11	1378	290.706
							M_2 c n_2 Eck n_2 th	0.11	1258	327.556
							M_2 c n_2 Eck n_2 th	0.08	1378	352.811
							M_2 c n_2 Eck n_2 th	0.08	1258	397.533
							M_2 c n_2 Eck n_2 th	0.1	1270	430.222
							M_2 c n_2 Eck n_2 th	0.08	1270	522.133
							M_2 c n_2 Eck n_2 th	0.07	1128	562.391
							M_2 c n_2 Eck n_2 th	0.07	1220	633.68

M ... [Nm]
n ... [min⁻¹]
J ... [kgcm²]

P ... [kW]
I ... [A]
i [-]
c [-]

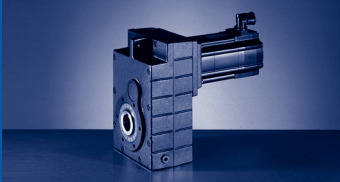

GFL [Nm]

GFL□□-□S (MCS)

$M_{2GN} \leq 2767 \text{ Nm}$

GFL09-2S				12DC20	12DC41	12HC15	12HC30	12HC35	12LC20	12LC41	14DC15	14DC36	14HC15
				...500	...500	...500	...500	...500	...500	...500	...500	...500	...500
i	M_{2GN}	J_G	M_1	5.5	4.3	10	8	7.5	13.5	11	9.2	7.5	16
			n_1	1950	4050	1500	3000	3525	1950	4050	1500	3600	1500
			I_{M230}	5.2	8.8	7.6	10.5		11.8				
			I_{M400}	2.6	4.5	3.8		5.7	5.9	10.2	4.5	7.5	6.6
			P_N	1.1	1.8	1.6	2.5	2.8	2.8	4.7	1.45	2.8	2.5
			J_M	4.12	4.12	7.42	7.42	7.42	10.72	10.72	8.22	8.22	14.32
6.864	1207	41.3	M_2 c $n_{2 \text{ Eck}}$ $n_{2 \text{ th}}$										
7.466	1313	38.7	M_2 c $n_{2 \text{ Eck}}$ $n_{2 \text{ th}}$										
9.01	860	26.8	M_2 c $n_{2 \text{ Eck}}$ $n_{2 \text{ th}}$										
9.01	1336	26.8	M_2 c $n_{2 \text{ Eck}}$ $n_{2 \text{ th}}$										
9.799	935	25.3	M_2 c $n_{2 \text{ Eck}}$ $n_{2 \text{ th}}$										
9.799	1453	25.3	M_2 c $n_{2 \text{ Eck}}$ $n_{2 \text{ th}}$										
11.167	976	19.5	M_2 c $n_{2 \text{ Eck}}$ $n_{2 \text{ th}}$										165 5.6 134 134
11.167	1516	19.5	M_2 c $n_{2 \text{ Eck}}$ $n_{2 \text{ th}}$										
12.307	2165	27.6	M_2 c $n_{2 \text{ Eck}}$ $n_{2 \text{ th}}$										
14.333	1368	20	M_2 c $n_{2 \text{ Eck}}$ $n_{2 \text{ th}}$										
14.333	2125	20	M_2 c $n_{2 \text{ Eck}}$ $n_{2 \text{ th}}$										
16.333	1427	15.5	M_2 c $n_{2 \text{ Eck}}$ $n_{2 \text{ th}}$										241 5.6 92 92
16.333	2217	15.5	M_2 c $n_{2 \text{ Eck}}$ $n_{2 \text{ th}}$										

$M \dots$ [Nm]
 $n \dots$ [min^{-1}]
 $J \dots$ [kgcm^2]

$P \dots$ [kW]
 $I \dots$ [A]
 i [-]
 c [-]

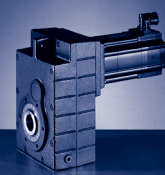

$M_{2GN} \leq 2767 \text{ Nm}$

14HC32	14LC15	14LC32	14PC14	14PC32	19FC14	19FC30	19JC14	19JC30	19PC14	19PC30	GFL09-2S			
...S00	...S00	...S00	...S00	...S00	...S00	...S00	...S00	...S00	...S00	...S00	M_1	J_G	M_{2GN}	i
14	23	17.2	30	21	27	21	40	29	51	32	n_1			
3225	1500	3225	1350	3225	1425	3000	1425	3000	1350	3000	I_{M230}			
											I_{M400}			
11.9	9.7	15	10.8	15.6	8.6	14	12.3	18.5	14.3	19	P_N			
4.7	3.6	5.8	4.2	7.1	4	6.6	6	9.1	7.2	10	J_M			
14.32	23.44	23.44	34.74	34.82	65.12	65.04	105.04	105.12	160.12	160.04	M_2			
							257	185	331	205	c	41.3	1207	6.864
							4.5	5	3.6	4.5	$n_{2 \text{ Eck}}$			
							208	437	197	437	$n_{2 \text{ th}}$			
							208	294	197	288	M_2			
							279	201	360	223	c	38.7	1313	7.466
							4.5	5	3.6	4.5	$n_{2 \text{ Eck}}$			
							191	402	181	402	$n_{2 \text{ th}}$			
							191	271	181	265	M_2			
117	194	145	256	179							c	26.8	860	9.01
5.4	4.3	4.4	3.3	3.6							$n_{2 \text{ Eck}}$			
358	167	358	150	358							$n_{2 \text{ th}}$			
259	166	249	150	238							M_2			
					225	175	339	245	437	272	c	26.8	1336	9.01
					5.7	5.8	3.8	4.2	3	3.8	$n_{2 \text{ Eck}}$			
					158	333	158	333	150	333	$n_{2 \text{ th}}$			
					158	245	158	245	150	241	M_2			
127	211	158	279	194							c	25.3	935	9.799
5.4	4.3	4.4	3.3	3.6							$n_{2 \text{ Eck}}$			
329	153	329	138	329							$n_{2 \text{ th}}$			
239	153	229	138	219							M_2			
					244	190	369	267	475	295	c	25.3	1453	9.799
					5.7	5.8	3.8	4.2	3	3.8	$n_{2 \text{ Eck}}$			
					145	306	145	306	138	306	$n_{2 \text{ th}}$			
					145	226	145	226	138	221	M_2			
145	242	180	318	222							c	19.5	976	11.167
5	3.9	4.1	3	3.3							$n_{2 \text{ Eck}}$			
289	134	289	121	289							$n_{2 \text{ th}}$			
225	134	216	121	207							M_2			
					280	217	422	305	543	338	c	19.5	1516	11.167
					5.2	5.3	3.5	3.8	2.7	3.5	$n_{2 \text{ Eck}}$			
					128	269	128	269	121	269	$n_{2 \text{ th}}$			
					128	198	128	198	121	198	M_2			
							460	332	593	368	c	27.6	2165	12.307
							4.5	5	3.6	4.5	$n_{2 \text{ Eck}}$			
							116	244	110	244	$n_{2 \text{ th}}$			
							116	164	110	161	M_2			
186	309	231	407	284							c	20	1368	14.333
5.4	4.3	4.4	3.3	3.6							$n_{2 \text{ Eck}}$			
225	105	225	94	225							$n_{2 \text{ th}}$			
163	105	156	94	150							M_2			
					357	278	540	390	695	432	c	20	2125	14.333
					5.7	5.8	3.8	4.2	3	3.8	$n_{2 \text{ Eck}}$			
					99	209	99	209	94	209	$n_{2 \text{ th}}$			
					99	154	99	154	94	151	M_2			
213	354	264	466	325							c	15.5	1427	16.333
5	3.9	4.1	3	3.3							$n_{2 \text{ Eck}}$			
198	92	198	83	198							$n_{2 \text{ th}}$			
154	92	147	83	141							M_2			
					409	318	618	446	794	494	c	15.5	2217	16.333
					5.2	5.3	3.5	3.8	2.7	3.5	$n_{2 \text{ Eck}}$			
					87	184	87	184	83	184	$n_{2 \text{ th}}$			
					87	135	87	135	83	135	M_2			

$M \dots$ [Nm]
 $n \dots$ [min^{-1}]
 $J \dots$ [kgcm^2]

$P \dots$ [kW]
 $I \dots$ [A]
 i [-]
 c [-]

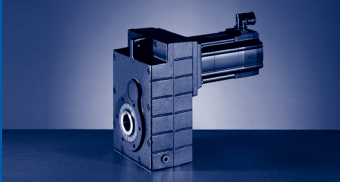

GFL [Nm]

GFL□□-□S (MCS)

$M_{2GN} \leq 2767 \text{ Nm}$

GFL09-2S				12DC20	12DC41	12HC15	12HC30	12HC35	12LC20	12LC41	14DC15	14DC36	14HC15
				...500	...500	...500	...500	...500	...500	...500	...500	...500	...500
i	M_{2GN}	J_G	M_1	5.5	4.3	10	8	7.5	13.5	11	9.2	7.5	16
			n_1	1950	4050	1500	3000	3525	1950	4050	1500	3600	1500
			I_{M230}	5.2	8.8	7.6	10.5		11.8				
			I_{M400}	2.6	4.5	3.8		5.7	5.9	10.2	4.5	7.5	6.6
			P_N	1.1	1.8	1.6	2.5	2.8	2.8	4.7	1.45	2.8	2.5
			J_M	4.12	4.12	7.42	7.42	7.42	10.72	10.72	8.22	8.22	14.32
18.407	1608	14.6	M_2										272
			c										5.6
			n_2 Eck										82
			n_2 th										81
18.407	2480	14.6	M_2										
			c										
			n_2 Eck										
			n_2 th										
19.667	962	12.1	M_2			183	146	137	251	205			
			c			5	5	5.1	3.4	3.3			
			n_2 Eck			76	153	179	99	206			
			n_2 th			76	145	145	99	132			
19.667	1506	12.1	M_2										293
			c										4.9
			n_2 Eck										76
			n_2 th										76
19.667	2339	12.1	M_2										
			c										
			n_2 Eck										
			n_2 th										
22.164	1084	11.3	M_2			206	165	155	283	231			
			c			5	5	5.1	3.4	3.3			
			n_2 Eck			68	135	159	88	183			
			n_2 th			68	128	129	88	118			
22.164	1697	11.3	M_2										330
			c										4.9
			n_2 Eck										68
			n_2 th										68
22.164	2612	11.3	M_2										
			c										
			n_2 Eck										
			n_2 th										
24.111	1585	9.04	M_2										362
			c										4.2
			n_2 Eck										62
			n_2 th										62
24.111	2463	9.04	M_2										
			c										
			n_2 Eck										
			n_2 th										
27.173	1786	8.63	M_2										408
			c										4.2
			n_2 Eck										55
			n_2 th										55
27.173	2767	8.63	M_2										
			c										
			n_2 Eck										
			n_2 th										
32.667	1074	5.43	M_2			309	246	231	421	343			
			c			3.4	3.8	3.9	2.5	2.5			
			n_2 Eck			46	92	108	60	124			
			n_2 th			46	92	108	60	100			

$M \dots$ [Nm]
 $n \dots$ [min^{-1}]
 $J \dots$ [kgcm^2]

$P \dots$ [kW]
 $I \dots$ [A]
 $i \dots$ [-]
 $c \dots$ [-]

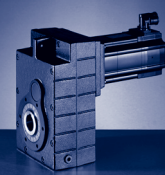

$M_{2GN} \leq 2767 \text{ Nm}$

14HC32	14LC15	14LC32	14PC14	14PC32	19FC14	19FC30	19JC14	19JC30	19PC14	19PC30	GFL09-2S			
...S00	...S00	...S00	...S00	...S00	...S00	...S00	...S00	...S00	...S00	...S00	M_1	J_G	M_{2GN}	i
14	23	17.2	30	21	27	21	40	29	51	32	n_1			
3225	1500	3225	1350	3225	1425	3000	1425	3000	1350	3000	I_{M230}			
											I_{M400}			
11.9	9.7	15	10.8	15.6	8.6	14	12.3	18.5	14.3	19	P_N			
4.7	3.6	5.8	4.2	7.1	4	6.6	6	9.1	7.2	10	J_M			
14.32	23.44	23.44	34.74	34.82	65.12	65.04	105.04	105.12	160.12	160.04	M_2			
240	398	298	525	366							c	14.6	1608	18.407
5	3.9	4.1	3	3.3							$n_{2 \text{ Eck}}$			
175	82	175	73	175							$n_{2 \text{ th}}$			
137	81	131	73	125										
					462	359	696	503	895	557	M_2			
					5.1	5.3	3.5	3.8	2.7	3.4	c	14.6	2480	18.407
					77	163	77	163	73	163	$n_{2 \text{ Eck}}$			
					77	120	77	120	73	120	$n_{2 \text{ th}}$			
											M_2			
											c	12.1	962	19.667
											$n_{2 \text{ Eck}}$			
											$n_{2 \text{ th}}$			
258	428	320	563	393							M_2			
4.4	3.4	3.6	2.6	2.9							c	12.1	1506	19.667
164	76	164	69	164							$n_{2 \text{ Eck}}$			
141	76	135	69	129							$n_{2 \text{ th}}$			
					496	386	747	540	959	598	M_2			
					4.5	4.6	3.1	3.4	2.4	3	c	12.1	2339	19.667
					73	153	73	153	69	153	$n_{2 \text{ Eck}}$			
					72	112	72	112	69	112	$n_{2 \text{ th}}$			
											M_2			
											c	11.3	1084	22.164
											$n_{2 \text{ Eck}}$			
											$n_{2 \text{ th}}$			
291	482	360	634	443							M_2			
4.4	3.4	3.6	2.6	2.9							c	11.3	1697	22.164
146	68	146	61	146							$n_{2 \text{ Eck}}$			
125	68	119	61	114							$n_{2 \text{ th}}$			
					560	435	842	609	1081	674	M_2			
					4.5	4.6	3	3.3	2.4	3	c	11.3	2612	22.164
					64	135	64	135	61	135	$n_{2 \text{ Eck}}$			
					64	100	64	100	61	100	$n_{2 \text{ th}}$			
317	527	392	693	482							M_2			
4.3	3	3.5	2.3	2.8							c	9.04	1585	24.111
134	62	134	56	134							$n_{2 \text{ Eck}}$			
124	62	119	56	114							$n_{2 \text{ th}}$			
					613	473	920	662	1180	733	M_2			
					3.9	4.5	2.6	3.3	2.1	3	c	9.04	2463	24.111
					59	124	59	124	56	124	$n_{2 \text{ Eck}}$			
					59	92	59	92	56	92	$n_{2 \text{ th}}$			
357	594	442	781	543							M_2			
4.3	3	3.5	2.3	2.8							c	8.63	1786	27.173
119	55	119	50	119							$n_{2 \text{ Eck}}$			
110	55	105	50	101							$n_{2 \text{ th}}$			
					691	534	1037	747	1330	827	M_2			
					3.9	4.5	2.6	3.3	2.1	3	c	8.63	2767	27.173
					52	110	52	110	50	110	$n_{2 \text{ Eck}}$			
					52	81	52	81	50	81	$n_{2 \text{ th}}$			
											M_2			
											c	5.43	1074	32.667
											$n_{2 \text{ Eck}}$			
											$n_{2 \text{ th}}$			

$M \dots$ [Nm]
 $n \dots$ [min^{-1}]
 $J \dots$ [kgcm^2]

$P \dots$ [kW]
 $I \dots$ [A]
 $i [-]$
 $c [-]$

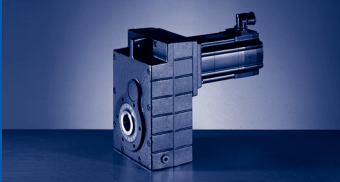

GFL [Nm]

GFL□□-□S (MCS)

$M_{2GN} \leq 2767 \text{ Nm}$

GFL09-2S				12DC20	12DC41	12HC15	12HC30	12HC35	12LC20	12LC41	14DC15	14DC36	14HC15
				...500	...500	...500	...500	...500	...500	...500	...500	...500	...500
i	M_{2GN}	J_G	M_1	5.5	4.3	10	8	7.5	13.5	11	9.2	7.5	16
			n_1	1950	4050	1500	3000	3525	1950	4050	1500	3600	1500
			I_{M230}	5.2	8.8	7.6	10.5		11.8				
			I_{M400}	2.6	4.5	3.8		5.7	5.9	10.2	4.5	7.5	6.6
			P_N	1.1	1.8	1.6	2.5	2.8	2.8	4.7	1.45	2.8	2.5
			J_M	4.12	4.12	7.42	7.42	7.42	10.72	10.72	8.22	8.22	14.32
32.667	1678	5.43	M_2								277	225	495
			c								5.8	6	3.3
			$n_{2 \text{ Eck}}$								46	110	46
			$n_{2 \text{ th}}$								46	110	46
36.815	1211	5.21	M_2			348	277	260	475	387			
			c			3.4	3.8	3.9	2.5	2.5			
			$n_{2 \text{ Eck}}$			41	82	96	53	110			
			$n_{2 \text{ th}}$			41	81	96	53	89			
36.815	1891	5.21	M_2								313	254	558
			c								5.8	6	3.3
			$n_{2 \text{ Eck}}$								41	98	41
			$n_{2 \text{ th}}$								41	98	41
39.667	1118	4.07	M_2	202	158	377	301	282	513	418			
			c	5.3	5.5	2.9	3.3	3.3	2.2	2.2			
			$n_{2 \text{ Eck}}$	49	102	38	76	89	49	102			
			$n_{2 \text{ th}}$	49	102	38	76	89	49	95			
39.667	1743	4.07	M_2								340	276	604
			c								4.9	5.1	2.8
			$n_{2 \text{ Eck}}$								38	91	38
			$n_{2 \text{ th}}$								38	91	38
44.704	1260	3.92	M_2	228	178	425	339	318	579	471			
			c	5.3	5.5	2.9	3.3	3.3	2.2	2.2			
			$n_{2 \text{ Eck}}$	44	91	34	67	79	44	91			
			$n_{2 \text{ th}}$	44	91	34	67	79	44	84			
44.704	1965	3.92	M_2								383	311	681
			c								4.9	5.1	2.8
			$n_{2 \text{ Eck}}$								34	81	34
			$n_{2 \text{ th}}$								34	80	34
51.333	1160	2.59	M_2	265	207	491	392	367	667	544			
			c	4.2	4.4	2.3	2.6	2.7	1.7	1.7			
			$n_{2 \text{ Eck}}$	38	79	29	58	69	38	79			
			$n_{2 \text{ th}}$	38	79	29	58	69	38	78			
51.333	1808	2.59	M_2								444	362	786
			c								4	4.1	2.3
			$n_{2 \text{ Eck}}$								29	70	29
			$n_{2 \text{ th}}$								29	70	29
57.852	1307	2.5	M_2	298	233	554	442	414	752	613			
			c	4.2	4.4	2.3	2.6	2.7	1.7	1.7			
			$n_{2 \text{ Eck}}$	34	70	26	52	61	34	70			
			$n_{2 \text{ th}}$	34	70	26	52	61	34	69			
57.852	2038	2.5	M_2								501	407	886
			c								4	4.1	2.3
			$n_{2 \text{ Eck}}$								26	62	26
			$n_{2 \text{ th}}$								26	62	26
62.3	1174	1.89	M_2	324	253	599	478	448	812	662			
			c	3.5	3.7	1.9	2.2	2.2	1.4	1.4			
			$n_{2 \text{ Eck}}$	31	65	24	48	57	31	65			
			$n_{2 \text{ th}}$	31	65	24	48	57	31	65			
62.3	1829	1.89	M_2								543	442	958
			c								3.3	3.4	1.9
			$n_{2 \text{ Eck}}$								24	58	24
			$n_{2 \text{ th}}$								24	58	24

$M \dots$ [Nm]
 $n \dots$ [min^{-1}]
 $J \dots$ [kgcm^2]

$P \dots$ [kW]
 $I \dots$ [A]
 $i \dots$ [-]
 $c \dots$ [-]

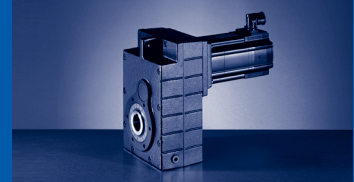

$M_{2GN} \leq 2767 \text{ Nm}$

14HC32	14LC15	14LC32	14PC14	14PC32	19FC14	19FC30	19JC14	19JC30	19PC14	19PC30	GFL09-2S			
...500	...500	...500	...500	...500	...500	...500	...500	...500	...500	...500	M_1	J_G	M_{2GN}	i
14	23	17.2	30	21	27	21	40	29	51	32	n_1			
3225	1500	3225	1350	3225	1425	3000	1425	3000	1350	3000	I_{M230}			
											I_{M400}			
11.9	9.7	15	10.8	15.6	8.6	14	12.3	18.5	14.3	19	P_N			
4.7	3.6	5.8	4.2	7.1	4	6.6	6	9.1	7.2	10	J_M			
14.32	23.44	23.44	34.74	34.82	65.12	65.04	105.04	105.12	160.12	160.04	M_2			
433	719	536	943	657							c			
3.3	2.3	2.7	1.8	2.2							$n_{2 \text{ Eck}}$	5.43	1678	32.667
99	46	99	41	99							$n_{2 \text{ th}}$			
99	46	99	41	98							M_2			
											c			
											$n_{2 \text{ Eck}}$	5.21	1211	36.815
											$n_{2 \text{ th}}$			
488	811	604	1063	741							M_2			
3.3	2.3	2.7	1.8	2.2							c			
88	41	88	37	88							$n_{2 \text{ Eck}}$	5.21	1891	36.815
88	41	88	37	87							$n_{2 \text{ th}}$			
											M_2			
											c			
											$n_{2 \text{ Eck}}$	4.07	1118	39.667
											$n_{2 \text{ th}}$			
529	876	653	1148	801							M_2			
2.9	2	2.3	1.5	1.9							c			
81	38	81	34	81							$n_{2 \text{ Eck}}$	4.07	1743	39.667
81	38	81	34	81							$n_{2 \text{ th}}$			
											M_2			
											c			
											$n_{2 \text{ Eck}}$	3.92	1260	44.704
											$n_{2 \text{ th}}$			
596	988	736	1294	902							M_2			
2.9	2	2.3	1.5	1.9							c			
72	34	72	30	72							$n_{2 \text{ Eck}}$	3.92	1965	44.704
72	34	72	30	72							$n_{2 \text{ th}}$			
											M_2			
											c			
											$n_{2 \text{ Eck}}$	2.59	1160	51.333
											$n_{2 \text{ th}}$			
688	1139	849	1491	1040							M_2			
2.3	1.6	1.9	1.2	1.5							c			
63	29	63	26	63							$n_{2 \text{ Eck}}$	2.59	1808	51.333
63	29	63	26	63							$n_{2 \text{ th}}$			
											M_2			
											c			
											$n_{2 \text{ Eck}}$	2.5	1307	57.852
											$n_{2 \text{ th}}$			
775	1283	957	1680	1172							M_2			
2.3	1.6	1.9	1.2	1.5							c			
56	26	56	23	56							$n_{2 \text{ Eck}}$	2.5	2038	57.852
56	26	56	23	56							$n_{2 \text{ th}}$			
											M_2			
											c			
											$n_{2 \text{ Eck}}$	1.89	1174	62.3
											$n_{2 \text{ th}}$			
838	1386	1034	1813	1266							M_2			
1.9	1.3	1.6	1	1.3							c			
52	24	52	22	52							$n_{2 \text{ Eck}}$	1.89	1829	62.3
52	24	52	22	52							$n_{2 \text{ th}}$			

$M \dots$ [Nm]
 $n \dots$ [min^{-1}]
 $J \dots$ [kgcm^2]

$P \dots$ [kW]
 $I \dots$ [A]
 $i [-]$
 $c [-]$

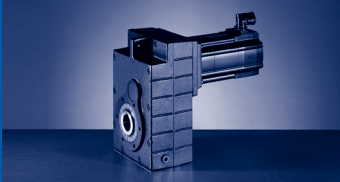

GFL [Nm]

GFL□□-□S (MCS)

$M_{2GN} \leq 2767 \text{ Nm}$

GFL09-2S				12DC20	12DC41	12HC15	12HC30	12HC35	12LC20	12LC41	14DC15	14DC36	14HC15	
				...500	...500	...500	...500	...500	...500	...500	...500	...500	...500	
i	M_{2GN}	J_G	M_1	5.5	4.3	10	8	7.5	13.5	11	9.2	7.5	16	
			n_1	1950	4050	1500	3000	3525	1950	4050	1500	3600	1500	
			I_{M230}	5.2	8.8	7.6	10.5		11.8					
			I_{M400}	2.6	4.5	3.8		5.7	5.9	10.2	4.5	7.5	6.6	
			P_N	1.1	1.8	1.6	2.5	2.8	2.8	4.7	1.45	2.8	2.5	
			J_M	4.12	4.12	7.42	7.42	7.42	10.72	10.72	8.22	8.22	14.32	
70.211	1324	1.83	M_2	365	284	675	537	503	915	745				
			c	3.5	4.1	1.9	2.4	2.5	1.4	1.6				
			n_2 Eck	28	58	21	43	50	28	58				
			n_2 th	28	58	21	43	50	28	58				
70.211	2061	1.83	M_2								612	496	1080	
			c								3.3	3.8	1.9	
			n_2 Eck								21	51	21	
			n_2 th								21	51	21	
78.75	1190	1.25	M_2	412	321	760	605	567	1030	838				
			c	2.8	3.3	1.6	2	2	1.2	1.3				
			n_2 Eck	25	51	19	38	45	25	51				
			n_2 th	25	51	19	38	45	25	51				
88.75	1341	1.21	M_2	465	362	856	682	639	1161	944				
			c	2.8	3.3	1.6	2	2	1.2	1.3				
			n_2 Eck	22	46	17	34	40	22	46				
			n_2 th	22	46	17	34	40	22	46				

$M \dots$ [Nm]
 $n \dots$ [min^{-1}]
 $J \dots$ [kgcm^2]

$P \dots$ [kW]
 $I \dots$ [A]
 i [-]
 c [-]

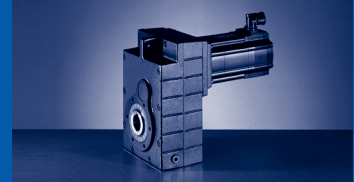

$M_{2GN} \leq 2767 \text{ Nm}$

14HC32	14LC15	14LC32	14PC14	14PC32	19FC14	19FC30	19JC14	19JC30	19PC14	19PC30	GFL09-2S			
...S00	...S00	...S00	...S00	...S00	...S00	...S00	...S00	...S00	...S00	...S00	M_1	J_G	M_{2GN}	i
14	23	17.2	30	21	27	21	40	29	51	32	n_1			
3225	1500	3225	1350	3225	1425	3000	1425	3000	1350	3000	I_{M230}			
											I_{M400}			
11.9	9.7	15	10.8	15.6	8.6	14	12.3	18.5	14.3	19	P_N			
4.7	3.6	5.8	4.2	7.1	4	6.6	6	9.1	7.2	10	J_M			
14.32	23.44	23.44	34.74	34.82	65.12	65.04	105.04	105.12	160.12	160.04	M_2 c			
											$n_{2 \text{ Eck}}$	1.83	1324	70.211
											$n_{2 \text{ th}}$			
943	1562	1163	2043	1425							M_2 c			
2.1	1.3	1.7	1	1.4							$n_{2 \text{ Eck}}$	1.83	2061	70.211
46	21	46	19	46							$n_{2 \text{ th}}$			
46	21	46	19	46							M_2 c			
											$n_{2 \text{ Eck}}$	1.25	1190	78.75
											$n_{2 \text{ th}}$			
											M_2 c			
											$n_{2 \text{ Eck}}$	1.21	1341	88.75
											$n_{2 \text{ th}}$			

M ... [Nm]
n ... [min⁻¹]
J ... [kgcm²]

P ... [kW]
I ... [A]
i [-]
c [-]

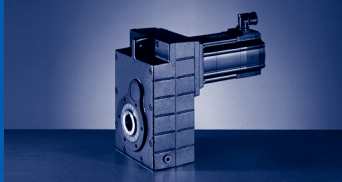

GFL [Nm]

GFL□□-□S (MCS)

$M_{2GN} \leq 3170 \text{ Nm}$

GFL09-3S				06CC41	06FC41	06IC41	09DC41	09FC38	09HC41	09LC41	12DC20	12DC41	12HC15	
				...500	...500	...500	...500	...500	...500	...500	...500	...500	...500	
i	M_{2GN}	J_G	M_1	0.6	1.2	1.5	2.3	3.1	3.8	4.5	5.5	4.3	10	
			n_1	4050	4050	4050	4050	3750	4050	4050	1950	4050	1500	
			I_{M230}	2.6	2.9	3.2	4.6	5	6.8	8.4	5.2	8.8	7.6	
			I_{M400}	1.3	1.5	1.6	2.3	2.5	3.4	4.2	2.6	4.5	3.8	
			P_N	0.25	0.51	0.64	1	1.2	1.6	1.9	1.1	1.8	1.6	
			J_M	0.17	0.25	0.33	1.13	1.53	1.93	2.83	4.12	4.12	7.42	
63.326	1510	2.34	M_2						219	262	321	250	596	
			c						5.4	4.5	4.5	4.7	2.5	
			$n_{2 \text{ Eck}}$							64	64	31	64	24
			$n_{2 \text{ th}}$							64	64	31	64	24
73.173	1517	2.47	M_2						254	304	373	289	691	
			c						5.2	4.4	4	4.6	2.2	
			$n_{2 \text{ Eck}}$							55	55	27	55	21
			$n_{2 \text{ th}}$							55	55	27	55	21
82.465	1710	2.43	M_2						286	342	420	326	778	
			c						5.2	4.4	4	4.6	2.2	
			$n_{2 \text{ Eck}}$							49	49	24	49	18
			$n_{2 \text{ th}}$							49	49	24	49	18
93.333	1692	1.68	M_2					263	326	390	478	372	884	
			c					5.7	4.5	3.8	3.5	4	1.9	
			$n_{2 \text{ Eck}}$						40	43	43	21	43	16
			$n_{2 \text{ th}}$						40	43	43	21	43	16
105.185	1907	1.65	M_2					296	368	439	539	419	996	
			c					5.7	4.5	3.8	3.5	4	1.9	
			$n_{2 \text{ Eck}}$						36	39	39	19	39	14
			$n_{2 \text{ th}}$						36	39	39	19	39	14
114.333	1847	1.23	M_2					324	402	479	588	457	1085	
			c					5.1	4	3.4	3.1	3.6	1.7	
			$n_{2 \text{ Eck}}$						33	35	35	17	35	13
			$n_{2 \text{ th}}$						33	35	35	17	35	13
128.852	2082	1.21	M_2					366	453	540	663	515	1223	
			c					5.1	4	3.4	3.1	3.6	1.7	
			$n_{2 \text{ Eck}}$						29	31	31	15	31	12
			$n_{2 \text{ th}}$						29	31	31	15	31	12
148.815	2053	0.77	M_2				311	426	527	627	769	598	1416	
			c				5.7	4.3	3.4	2.9	2.6	3	1.4	
			$n_{2 \text{ Eck}}$					27	25	27	13	27	10	
			$n_{2 \text{ th}}$					27	25	27	13	27	10	
167.712	2314	0.76	M_2				351	480	594	707	867	674	1595	
			c				5.7	4.3	3.4	2.9	2.6	3	1.4	
			$n_{2 \text{ Eck}}$					24	22	24	12	24	9	
			$n_{2 \text{ th}}$					24	22	24	12	24	9	
185.111	1724	0.55	M_2			252								
			c			5.9								
			$n_{2 \text{ Eck}}$											
			$n_{2 \text{ th}}$											
185.111	2232	0.55	M_2				390	532	658	783	960	748	1764	
			c				5	3.8	3	2.5	2.3	2.7	1.3	
			$n_{2 \text{ Eck}}$					22	20	22	22	11	22	8
			$n_{2 \text{ th}}$					22	20	22	22	11	22	8
208.617	1943	0.54	M_2			284								
			c			5.9								
			$n_{2 \text{ Eck}}$											
			$n_{2 \text{ th}}$											
208.617	2515	0.54	M_2				440	600	742	883	1082	842	1988	
			c				5	3.8	3	2.5	2.3	2.7	1.3	
			$n_{2 \text{ Eck}}$					19	18	19	19	9	19	7
			$n_{2 \text{ th}}$					19	18	19	19	9	19	7

$M \dots [\text{Nm}]$
 $n \dots [\text{min}^{-1}]$
 $J \dots [\text{kgcm}^2]$

$P \dots [\text{kW}]$
 $I \dots [\text{A}]$
 $i \dots [-]$
 $c \dots [-]$

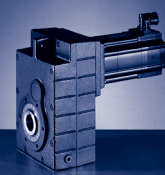

$M_{2GN} \leq 3170 \text{ Nm}$

12HC30	12HC35	12LC20	12LC41	14DC15	14DC36	14HC15	14HC32	14LC15	14LC32	14PC32	GFL09-3S			
...S00	...S00	...S00	...S00	...S00	...S00	...S00	...S00	...S00	...S00	...S00	M_1	J_G	M_{2GN}	i
8	7.5	13.5	11	9.2	7.5	16	14	23	17.2	21	n_1			
3000	3525	1950	4050	1500	3600	1500	3225	1500	3225	3225	I_{M230}			
10.5		11.8									I_{M400}			
	5.7	5.9	10.2	4.5	7.5	6.6	11.9	9.7	15	15.6	P_N			
2.5	2.8	2.8	4.7	1.45	2.8	2.5	4.7	3.6	5.8	7.1	J_M			
7.42	7.42	10.72	10.72	8.22	8.22	14.32	14.32	23.44	23.44	34.82	M_2			
475	445	810	660	547	445	963	842	1391	1038	1270	c			
2.8	2.8	1.9	1.9	2.7	2.8	1.6	1.6	1.1	1.3	1.1	$n_{2 \text{ Eck}}$	2.34	1510	63.326
47	56	31	64	24	57	24	51	24	51	51	$n_{2 \text{ th}}$			
47	56	31	64	24	57	24	51	24	51	51				
549	515	938	763	634	515	1115	974		1200	1468	M_2			
2.7	2.7	1.6	1.8	2.4	2.7	1.4	1.5		1.2	1	c	2.47	1517	73.173
41	48	27	55	21	49	21	44		44	44	$n_{2 \text{ Eck}}$			
41	48	27	49	21	49	21	44		41	37	$n_{2 \text{ th}}$			
619	580	1057	860	715	580	1256	1097		1352	1655	M_2			
2.7	2.7	1.6	1.8	2.4	2.7	1.4	1.5		1.2	1	c	2.43	1710	82.465
36	43	24	49	18	44	18	39		39	39	$n_{2 \text{ Eck}}$			
36	43	24	44	18	44	18	39		36	33	$n_{2 \text{ th}}$			
703	659	1199	975	811	659	1424	1245		1533		M_2			
2.4	2.4	1.4	1.6	2.1	2.4	1.2	1.3		1.1		c	1.68	1692	93.333
32	38	21	43	16	39	16	35		35		$n_{2 \text{ Eck}}$			
32	38	21	41	16	38	16	35		35		$n_{2 \text{ th}}$			
793	743	1351	1099	915	743	1605	1403		1728		M_2			
2.4	2.4	1.4	1.6	2.1	2.4	1.2	1.3		1.1		c	1.65	1907	105.185
29	34	19	39	14	34	14	31		31		$n_{2 \text{ Eck}}$			
29	34	19	36	14	34	14	31		31		$n_{2 \text{ th}}$			
864	810	1471	1197	996	810	1747	1527				M_2			
2.1	2.1	1.3	1.4	1.8	2.1	1.1	1.2				c	1.23	1847	114.333
26	31	17	35	13	32	13	28				$n_{2 \text{ Eck}}$			
26	31	17	35	13	31	13	28				$n_{2 \text{ th}}$			
974	913	1658	1349	1123	913	1969	1721				M_2			
2.1	2.1	1.3	1.4	1.8	2.1	1.1	1.2				c	1.21	2082	128.852
23	27	15	31	12	28	12	25				$n_{2 \text{ Eck}}$			
23	27	15	31	12	28	12	25				$n_{2 \text{ th}}$			
1128	1057	1919	1561								M_2			
1.8	1.8	1.1	1.2								c	0.77	2053	148.815
20	24	13	27								$n_{2 \text{ Eck}}$			
20	24	13	27								$n_{2 \text{ th}}$			
1271	1192	2162	1760								M_2			
1.8	1.8	1.1	1.2								c	0.76	2314	167.712
18	21	12	24								$n_{2 \text{ Eck}}$			
18	21	12	24								$n_{2 \text{ th}}$			
											M_2			
											c	0.55	1724	185.111
											$n_{2 \text{ Eck}}$			
											$n_{2 \text{ th}}$			
1407	1319		1945								M_2			
1.6	1.6		1								c	0.55	2232	185.111
16	19		22								$n_{2 \text{ Eck}}$			
16	19		22								$n_{2 \text{ th}}$			
											M_2			
											c	0.54	1943	208.617
											$n_{2 \text{ Eck}}$			
											$n_{2 \text{ th}}$			
1585	1486		2192								M_2			
1.6	1.6		1								c	0.54	2515	208.617
14	17		19								$n_{2 \text{ Eck}}$			
14	17		19								$n_{2 \text{ th}}$			

$M \dots$ [Nm]
 $n \dots$ [min^{-1}]
 $J \dots$ [kgcm^2]

$P \dots$ [kW]
 $I \dots$ [A]
 $i [-]$
 $c [-]$

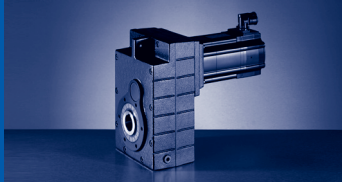

GFL [Nm]

GFL□□-□S (MCS)

$M_{2GN} \leq 3170 \text{ Nm}$

GFL09-3S				06CC41	06FC41	06IC41	09DC41	09FC38	09HC41	09LC41	12DC20	12DC41	12HC15
				...500	...500	...500	...500	...500	...500	...500	...500	...500	...500
i	M_{2GN}	J_G	M_1	0.6	1.2	1.5	2.3	3.1	3.8	4.5	5.5	4.3	10
			n_1	4050	4050	4050	4050	3750	4050	4050	1950	4050	1500
			I_{M230}	2.6	2.9	3.2	4.6	5	6.8	8.4	5.2	8.8	7.6
			I_{M400}	1.3	1.5	1.6	2.3	2.5	3.4	4.2	2.6	4.5	3.8
			P_N	0.25	0.51	0.64	1	1.2	1.6	1.9	1.1	1.8	1.6
			J_M	0.17	0.25	0.33	1.13	1.53	1.93	2.83	4.12	4.12	7.42
224.778	2093	0.51	M_2			306							
			c			5.9							
			$n_{2 \text{ Eck}}$			18							
			$n_{2 \text{ th}}$			18							
224.778	2407	0.51	M_2				476	650	802	954	1169	911	2145
			c				4.4	3.4	2.7	2.3	2	2.4	1.1
			$n_{2 \text{ Eck}}$				18	17	18	18	9	18	7
			$n_{2 \text{ th}}$				18	17	18	18	9	18	7
253.321	2359	0.5	M_2			345							
			c			5.9							
			$n_{2 \text{ Eck}}$			16							
			$n_{2 \text{ th}}$			16							
253.321	2712	0.5	M_2				537	732	904	1075	1317	1026	2418
			c				4.4	3.4	2.7	2.3	2	2.4	1.1
			$n_{2 \text{ Eck}}$				16	15	16	16	8	16	6
			$n_{2 \text{ th}}$				16	15	16	16	8	16	6
290.889	2172	0.31	M_2		317	401							
			c		5.9	4.7							
			$n_{2 \text{ Eck}}$		14	14							
			$n_{2 \text{ th}}$		14	14							
290.889	2640	0.31	M_2				621	845	1042	1239			
			c				3.7	2.8	2.3	1.9			
			$n_{2 \text{ Eck}}$				14	13	14	14			
			$n_{2 \text{ th}}$				14	13	14	14			
327.827	2447	0.31	M_2		357	452							
			c		5.9	4.7							
			$n_{2 \text{ Eck}}$		12	12							
			$n_{2 \text{ th}}$		12	12							
327.827	2976	0.31	M_2				700	952	1175	1396			
			c				3.7	2.8	2.3	1.9			
			$n_{2 \text{ Eck}}$				12	11	12	12			
			$n_{2 \text{ th}}$				12	11	12	12			
353.033	2197	0.23	M_2		388	491							
			c		4.9	3.9							
			$n_{2 \text{ Eck}}$		12	12							
			$n_{2 \text{ th}}$		11	11							
353.033	2813	0.23	M_2				757	1030	1269	1507			
			c				3.3	2.5	2	1.7			
			$n_{2 \text{ Eck}}$				12	11	12	12			
			$n_{2 \text{ th}}$				11	11	11	11			
397.863	2476	0.22	M_2		438	553							
			c		4.9	3.9							
			$n_{2 \text{ Eck}}$		10	10							
			$n_{2 \text{ th}}$		10	10							
397.863	3170	0.22	M_2				854	1160	1430	1699			
			c				3.3	2.5	2	1.7			
			$n_{2 \text{ Eck}}$				10	9	10	10			
			$n_{2 \text{ th}}$				10	9	10	10			
424.247	2724	0.29	M_2		466	589	916	1244	1531	1818			
			c		5.1	4.1	2.6	2	1.6	1.4			
			$n_{2 \text{ Eck}}$		10	10	10	9	10	10			
			$n_{2 \text{ th}}$		10	10	10	9	10	10			

$M \dots [\text{Nm}]$
 $n \dots [\text{min}^{-1}]$
 $J \dots [\text{kgcm}^2]$

$P \dots [\text{kW}]$
 $I \dots [\text{A}]$
 $i \dots [-]$
 $c \dots [-]$

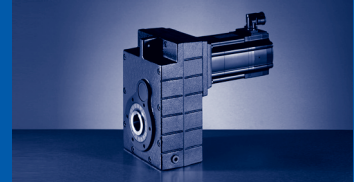

$M_{2GN} \leq 3170 \text{ Nm}$

12HC30	12HC35	12LC20	12LC41	14DC15	14DC36	14HC15	14HC32	14LC15	14LC32	14PC32	GFL09-3S			
...S00	...S00	...S00	...S00	...S00	...S00	...S00	...S00	...S00	...S00	...S00	M_1	J_G	M_{2GN}	i
8	7.5	13.5	11	9.2	7.5	16	14	23	17.2	21	n_1			
3000	3525	1950	4050	1500	3600	1500	3225	1500	3225	3225	I_{M230}			
10.5		11.8									I_{M400}			
	5.7	5.9	10.2	4.5	7.5	6.6	11.9	9.7	15	15.6	P_N			
2.5	2.8	2.8	4.7	1.45	2.8	2.5	4.7	3.6	5.8	7.1	J_M			
7.42	7.42	10.72	10.72	8.22	8.22	14.32	14.32	23.44	23.44	34.82	M_2			
											c	0.51	2093	224.778
											$n_{2 \text{ Eck}}$			
											$n_{2 \text{ th}}$			
1711	1604										M_2			
1.4	1.4										c	0.51	2407	224.778
13	16										$n_{2 \text{ Eck}}$			
13	16										$n_{2 \text{ th}}$			
											M_2			
											c	0.5	2359	253.321
											$n_{2 \text{ Eck}}$			
											$n_{2 \text{ th}}$			
1929	1808										M_2			
1.4	1.4										c	0.5	2712	253.321
12	14										$n_{2 \text{ Eck}}$			
12	14										$n_{2 \text{ th}}$			
											M_2			
											c	0.31	2172	290.889
											$n_{2 \text{ Eck}}$			
											$n_{2 \text{ th}}$			
											M_2			
											c	0.31	2640	290.889
											$n_{2 \text{ Eck}}$			
											$n_{2 \text{ th}}$			
											M_2			
											c	0.31	2447	327.827
											$n_{2 \text{ Eck}}$			
											$n_{2 \text{ th}}$			
											M_2			
											c	0.31	2976	327.827
											$n_{2 \text{ Eck}}$			
											$n_{2 \text{ th}}$			
											M_2			
											c	0.23	2197	353.033
											$n_{2 \text{ Eck}}$			
											$n_{2 \text{ th}}$			
											M_2			
											c	0.23	2813	353.033
											$n_{2 \text{ Eck}}$			
											$n_{2 \text{ th}}$			
											M_2			
											c	0.22	2476	397.863
											$n_{2 \text{ Eck}}$			
											$n_{2 \text{ th}}$			
											M_2			
											c	0.22	3170	397.863
											$n_{2 \text{ Eck}}$			
											$n_{2 \text{ th}}$			
											M_2			
											c	0.29	2724	424.247
											$n_{2 \text{ Eck}}$			
											$n_{2 \text{ th}}$			

$M \dots$ [Nm]
 $n \dots$ [min^{-1}]
 $J \dots$ [kgcm^2]

$P \dots$ [kW]
 $I \dots$ [A]
 i [-]
 c [-]

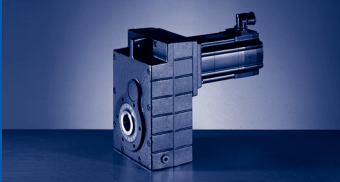

GFL [Nm]

GFL□□-□S (MCS)

$M_{2GN} \leq 3170 \text{ Nm}$

GFL09-3S				06CC41	06FC41	06IC41	09DC41	09FC38	09HC41	09LC41	12DC20	12DC41	12HC15
				...500	...500	...500	...500	...500	...500	...500	...500	...500	...500
i	M_{2GN}	J_G	M_1	0.6	1.2	1.5	2.3	3.1	3.8	4.5	5.5	4.3	10
			n_1	4050	4050	4050	4050	3750	4050	4050	1950	4050	1500
			I_{M230}	2.6	2.9	3.2	4.6	5	6.8	8.4	5.2	8.8	7.6
			I_{M400}	1.3	1.5	1.6	2.3	2.5	3.4	4.2	2.6	4.5	3.8
			P_N	0.25	0.51	0.64	1	1.2	1.6	1.9	1.1	1.8	1.6
			J_M	0.17	0.25	0.33	1.13	1.53	1.93	2.83	4.12	4.12	7.42
514.881	2724	0.21	M_2		571	720	1118	1515	1864	2212			
			c		4.2	3.3	2.2	1.7	1.3	1.1			
			$n_{2 \text{ Eck}}$		8	8	8	7	8	8			
			$n_{2 \text{ th}}$		8	8	8	7	8	8			
554.47	2113	0.2	M_2		623	783	1211	1639					
			c		3	2.4	1.6	1.2					
			$n_{2 \text{ Eck}}$		7	7	7	7					
			$n_{2 \text{ th}}$		7	7	7	7					
624.879	2273	0.2	M_2	341	703	884	1366	1849					
			c	5.7	2.9	2.3	1.5	1.1					
			$n_{2 \text{ Eck}}$	7	7	7	7	6					
			$n_{2 \text{ th}}$	6	6	6	6	6					
700.875	2113	0.13	M_2	386	792	995							
			c	4.8	2.4	1.9							
			$n_{2 \text{ Eck}}$	6	6	6							
			$n_{2 \text{ th}}$	6	6	6							
789.875	2273	0.13	M_2	436	894	1123							
			c	4.5	2.3	1.8							
			$n_{2 \text{ Eck}}$	5	5	5							
			$n_{2 \text{ th}}$	5	5	5							

M ... [Nm]
 n ... [min⁻¹]
 J ... [kgcm²]

P ... [kW]
 I ... [A]
 i [-]
 c [-]

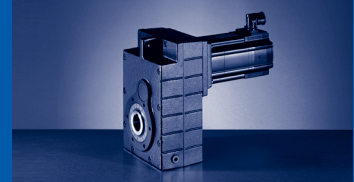

$M_{2GN} \leq 3170 \text{ Nm}$

12HC30	12HC35	12LC20	12LC41	14DC15	14DC36	14HC15	14HC32	14LC15	14LC32	14PC32	GFL09-3S			
...S00	...S00	...S00	...S00	...S00	...S00	...S00	...S00	...S00	...S00	...S00	M_1	J_G	M_{2GN}	i
8	7.5	13.5	11	9.2	7.5	16	14	23	17.2	21	n_1			
3000	3525	1950	4050	1500	3600	1500	3225	1500	3225	3225	I_{M230}			
10.5		11.8									I_{M400}			
	5.7	5.9	10.2	4.5	7.5	6.6	11.9	9.7	15	15.6	P_N			
2.5	2.8	2.8	4.7	1.45	2.8	2.5	4.7	3.6	5.8	7.1	J_M			
7.42	7.42	10.72	10.72	8.22	8.22	14.32	14.32	23.44	23.44	34.82	M_2			
											c	0.21	2724	514.881
											n_2 Eck			
											n_2 th			
											M_2	0.2	2113	554.47
											c			
											n_2 Eck			
											n_2 th	0.2	2273	624.879
											M_2			
											c	0.13	2113	700.875
											n_2 Eck			
											n_2 th			
											M_2			
											c	0.13	2273	789.875
											n_2 Eck			
											n_2 th			

M ... [Nm]
n ... [min^{-1}]
J ... [kgcm^2]

P ... [kW]
I ... [A]
i [-]
c [-]

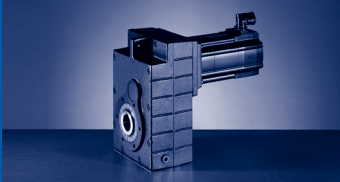

GFL [Nm]

GFL□□-□S (MCS)

$M_{2GN} \leq 3833 \text{ Nm}$

GFL11-2S				14DC15	14DC36	14HC15	14HC32	14LC15	14LC32	14PC14
				...S00	...S00	...S00	...S00	...S00	...S00	...S00
i	M_{2GN}	J_G	M_1							
			n_1	9.2	7.5	16	14	23	17.2	30
			I_{M400}	4.5	7.5	6.6	11.9	9.7	15	10.8
			P_N	1.45	2.8	2.5	4.7	3.6	5.8	4.2
			J_M	8.22	8.22	14.32	14.32	23.44	23.44	34.74
6.864	1502	124	M_2 c $n_{2 \text{ Eck}}$ $n_{2 \text{ th}}$							
7.466	1634	116	M_2 c $n_{2 \text{ Eck}}$ $n_{2 \text{ th}}$							
9.01	1663	79.6	M_2 c $n_{2 \text{ Eck}}$ $n_{2 \text{ th}}$							
9.799	1808	74.8	M_2 c $n_{2 \text{ Eck}}$ $n_{2 \text{ th}}$							
10.72	1872	65	M_2 c $n_{2 \text{ Eck}}$ $n_{2 \text{ th}}$							
12.48	2732	81.5	M_2 c $n_{2 \text{ Eck}}$ $n_{2 \text{ th}}$							
14.538	2683	58.4	M_2 c $n_{2 \text{ Eck}}$ $n_{2 \text{ th}}$							
15.904	2778	51.3	M_2 c $n_{2 \text{ Eck}}$ $n_{2 \text{ th}}$							
17.92	3130	48.3	M_2 c $n_{2 \text{ Eck}}$ $n_{2 \text{ th}}$							
20.286	1921	36.1	M_2 c $n_{2 \text{ Eck}}$ $n_{2 \text{ th}}$				263 5.4 159 115	438 4.2 74 74	327 4.4 159 111	577 3.3 67 67
20.286	2984	36.1	M_2 c $n_{2 \text{ Eck}}$ $n_{2 \text{ th}}$							
22.857	2165	34.3	M_2 c $n_{2 \text{ Eck}}$ $n_{2 \text{ th}}$				296 5.4 141 102	493 4.2 66 66	368 4.4 141 98	650 3.3 59 59
22.857	3362	34.3	M_2 c $n_{2 \text{ Eck}}$ $n_{2 \text{ th}}$							

$M \dots$ [Nm]
 $n \dots$ [min^{-1}]
 $J \dots$ [kgcm^2]

$P \dots$ [kW]
 $I \dots$ [A]
 i [-]
 c [-]

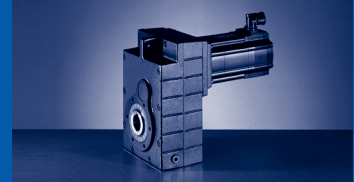

$M_{2GN} \leq 3833 \text{ Nm}$

14PC32	19FC14	19FC30	19JC14	19JC30	19PC14	19PC30	GFL11-2S			
...500	...500	...500	...500	...500	...500	...500				
21	27	21	40	29	51	32	M_1	J_G	M_{2GN}	i
3225	1425	3000	1425	3000	1350	3000	n_1			
15.6	8.6	14	12.3	18.5	14.3	19	I_{M400}			
7.1	4	6.6	6	9.1	7.2	10	P_N			
34.82	65.12	65.04	105.04	105.12	160.12	160.04	J_M			
			254		328	203	M_2			
			5.6		4.4	5.6	c	124	1502	6.864
			208		197	437	$n_{2 \text{ Eck}}$			
			208		197	253	$n_{2 \text{ th}}$			
			276		356	221	M_2			
			5.6		4.4	5.6	c	116	1634	7.466
			191		181	402	$n_{2 \text{ Eck}}$			
			191		181	233	$n_{2 \text{ th}}$			
			336	243	433	269	M_2			
			4.8	5.2	3.7	4.7	c	79.6	1663	9.01
			158	333	150	333	$n_{2 \text{ Eck}}$			
			158	221	150	216	$n_{2 \text{ th}}$			
			366	264	471	293	M_2			
			4.8	5.2	3.7	4.7	c	74.8	1808	9.799
			145	306	138	306	$n_{2 \text{ Eck}}$			
			145	203	138	199	$n_{2 \text{ th}}$			
			401	289	517	321	M_2			
			4.5	4.9	3.5	4.5	c	65	1872	10.72
			133	280	126	280	$n_{2 \text{ Eck}}$			
			133	189	126	185	$n_{2 \text{ th}}$			
			461		596	369	M_2			
			5.6		4.4	5.6	c	81.5	2732	12.48
			114		108	240	$n_{2 \text{ Eck}}$			
			114		108	139	$n_{2 \text{ th}}$			
			542	391	699	434	M_2			
			4.8	5.2	3.7	4.7	c	58.4	2683	14.538
			98	206	93	206	$n_{2 \text{ Eck}}$			
			98	137	93	134	$n_{2 \text{ th}}$			
			595	429	766	476	M_2			
			4.5	4.9	3.5	4.5	c	51.3	2778	15.904
			90	189	85	189	$n_{2 \text{ Eck}}$			
			90	127	85	125	$n_{2 \text{ th}}$			
			670	484	864	536	M_2			
			4.5	4.9	3.5	4.5	c	48.3	3130	17.92
			80	167	75	167	$n_{2 \text{ Eck}}$			
			80	113	75	111	$n_{2 \text{ th}}$			
402							M_2			
3.6							c	36.1	1921	20.286
159							$n_{2 \text{ Eck}}$			
106							$n_{2 \text{ th}}$			
	506	393	765	552	983	612	M_2			
	5.6	5.7	3.8	4.2	3	3.8	c	36.1	2984	20.286
	70	148	70	148	67	148	$n_{2 \text{ Eck}}$			
	70	109	70	109	67	107	$n_{2 \text{ th}}$			
453							M_2			
3.6							c	34.3	2165	22.857
141							$n_{2 \text{ Eck}}$			
94							$n_{2 \text{ th}}$			
	570	443	862	622	1108	689	M_2			
	5.6	5.7	3.8	4.2	3	3.8	c	34.3	3362	22.857
	62	131	62	131	59	131	$n_{2 \text{ Eck}}$			
	62	97	62	97	59	95	$n_{2 \text{ th}}$			

M ... [Nm]
n ... [min⁻¹]
J ... [kgcm²]

P ... [kW]
I ... [A]
i [-]
c [-]

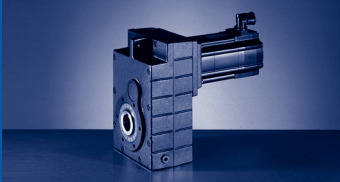

GFL [Nm]

GFL□□-□S (MCS)

$M_{2GN} \leq 3833 \text{ Nm}$

GFL11-2S				14DC15	14DC36	14HC15	14HC32	14LC15	14LC32	14PC14
				...500	...500	...500	...500	...500	...500	...500
i	M_{2GN}	J_G	M_1							
			n_1	9.2	7.5	16	14	23	17.2	30
			I_{M400}	4.5	7.5	6.6	11.9	9.7	15	10.8
			P_N	1.45	2.8	2.5	4.7	3.6	5.8	4.2
			J_M	8.22	8.22	14.32	14.32	23.44	23.44	34.74
24.85	3142	26.9	M_2 c n_2 Eck n_2 th							
28	3540	25.7	M_2 c n_2 Eck n_2 th							
32.739	2135	17.1	M_2 c n_2 Eck n_2 th			491 4.2 46 46	430 4.2 99 91	716 2.9 46 46	533 3.4 99 88	941 2.2 41 41
32.739	3319	17.1	M_2 c n_2 Eck n_2 th							
36.889	2406	16.5	M_2 c n_2 Eck n_2 th			554 4.2 41 41	484 4.2 87 81	807 2.9 41 41	600 3.4 87 78	1060 2.2 37 37
36.889	3740	16.5	M_2 c n_2 Eck n_2 th							
40.233	2189	12.6	M_2 c n_2 Eck n_2 th			608 3.5 37 37	532 3.5 80 80	885 2.4 37 37	658 2.9 80 80	1161 1.9 34 34
40.233	3402	12.6	M_2 c n_2 Eck n_2 th							
45.333	2467	12.2	M_2 c n_2 Eck n_2 th			686 3.5 33 33	600 3.5 71 71	997 2.4 33 33	742 2.9 71 71	1308 1.9 30 30
45.333	3833	12.2	M_2 c n_2 Eck n_2 th							
52.067	2270	8.08	M_2 c n_2 Eck n_2 th	446 4.9 29 29	363 5.1 69 69	793 2.8 29 29	694 2.8 62 62	1150 2 29 29	857 2.3 62 62	1508 1.5 26 26
58.667	2557	7.81	M_2 c n_2 Eck n_2 th	503 4.9 26 26	409 5.1 61 61	894 2.8 26 26	782 2.8 55 55	1296 2 26 26	966 2.3 55 55	1699 1.5 23 23
63.19	2297	5.9	M_2 c n_2 Eck n_2 th	546 4.1 24 24	444 4.2 57 57	967 2.3 24 24	846 2.4 51 51	1401 1.6 24 24	1045 1.9 51 51	1835 1.3 21 21

$M \dots$ [Nm]
 $n \dots$ [min^{-1}]
 $J \dots$ [kgcm^2]

$P \dots$ [kW]
 $I \dots$ [A]
 i [-]
 c [-]

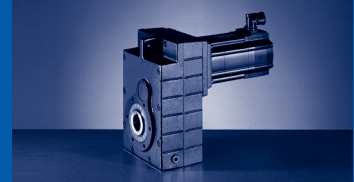

$M_{2GN} \leq 3833 \text{ Nm}$

14PC32	19FC14	19FC30	19JC14	19JC30	19PC14	19PC30	GFL11-2S			
...500	...500	...500	...500	...500	...500	...500				
21	27	21	40	29	51	32	M_1	J_G	M_{2GN}	i
3225	1425	3000	1425	3000	1350	3000	n_1			
15.6	8.6	14	12.3	18.5	14.3	19	I_{M400}			
7.1	4	6.6	6	9.1	7.2	10	P_N			
34.82	65.12	65.04	105.04	105.12	160.12	160.04	J_M			
	625	482	942	677	1210	750	M_2			
	4.8	5.6	3.3	4.1	2.6	3.7	c	26.9	3142	24.85
	57	121	57	121	54	121	n_{2Eck}			
	57	89	57	89	54	89	n_{2th}			
	705	543	1061	763	1363	845	M_2			
	4.8	5.6	3.3	4.1	2.6	3.7	c	25.7	3540	28
	51	107	51	107	48	107	n_{2Eck}			
	51	79	51	79	48	79	n_{2th}			
655							M_2			
2.8							c	17.1	2135	32.739
99							n_{2Eck}			
84							n_{2th}			
	832	643	1249	900	1602	996	M_2			
	3.9	4.5	2.6	3.3	2.1	3	c	17.1	3319	32.739
	44	92	44	92	41	92	n_{2Eck}			
	44	68	44	68	41	68	n_{2th}			
738							M_2			
2.8							c	16.5	2406	36.889
87							n_{2Eck}			
75							n_{2th}			
	938	725	1408	1014	1806	1122	M_2			
	3.9	4.5	2.6	3.3	2.1	3	c	16.5	3740	36.889
	39	81	39	81	37	81	n_{2Eck}			
	39	60	39	60	37	60	n_{2th}			
808							M_2			
2.4							c	12.6	2189	40.233
80							n_{2Eck}			
77							n_{2th}			
	1030	797	1542	1112	1976	1230	M_2			
	3.2	3.7	2.2	2.7	1.7	2.5	c	12.6	3402	40.233
	35	75	35	75	34	75	n_{2Eck}			
	35	55	35	55	34	55	n_{2th}			
911							M_2			
2.4							c	12.2	2467	45.333
71							n_{2Eck}			
68							n_{2th}			
	1160	898	1738	1253	2227	1386	M_2			
	3.2	3.7	2.2	2.7	1.7	2.5	c	12.2	3833	45.333
	31	66	31	66	30	66	n_{2Eck}			
	31	49	31	49	30	49	n_{2th}			
1051							M_2			
1.9							c	8.08	2270	52.067
62							n_{2Eck}			
62							n_{2th}			
1184							M_2			
1.9							c	7.81	2557	58.667
55							n_{2Eck}			
55							n_{2th}			
1280							M_2			
1.6							c	5.9	2297	63.19
51							n_{2Eck}			
51							n_{2th}			

M ... [Nm]
n ... [min⁻¹]
J ... [kgcm²]

P ... [kW]
I ... [A]
i [-]
c [-]

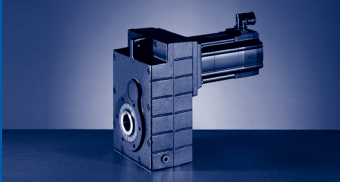

GFL [Nm]

GFL□□-□S (MCS)

$M_{2GN} \leq 3833 \text{ Nm}$

GFL11-2S				14DC15	14DC36	14HC15	14HC32	14LC15	14LC32	14PC14
				...500	...500	...500	...500	...500	...500	...500
i	M_{2GN}	J_G	M_1	9.2	7.5	16	14	23	17.2	30
			n_1	1500	3600	1500	3225	1500	3225	1350
			I_{M400}	4.5	7.5	6.6	11.9	9.7	15	10.8
			P_N	1.45	2.8	2.5	4.7	3.6	5.8	4.2
			J_M	8.22	8.22	14.32	14.32	23.44	23.44	34.74
71.2	2588	5.72	M_2	615	498	1090	951	1579	1174	2067
			c	4.1	4.7	2.3	2.6	1.6	2.1	1.3
			$n_{2 \text{ Eck}}$	21	51	21	45	21	45	19
			$n_{2 \text{ th}}$	21	50	21	45	21	45	19
			M_2	696	565	1229	1073	1777	1323	2325
79.875	2325	3.87	c	3.3	3.8	1.9	2.1	1.3	1.7	1
			$n_{2 \text{ Eck}}$	19	45	19	40	19	40	17
			$n_{2 \text{ th}}$	19	45	19	40	19	40	17
			M_2	785	636	1385	1209	2002	1491	2620
			c	3.3	3.8	1.9	2.1	1.3	1.7	1
90	2620	3.76	$n_{2 \text{ Eck}}$	17	40	17	36	17	36	15
			$n_{2 \text{ th}}$	17	40	17	36	17	36	15

M ... [Nm]
 n ... [min⁻¹]
 J ... [kgcm²]

P ... [kW]
 I ... [A]
 i [-]
 c [-]

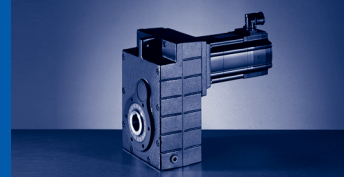

$M_{2GN} \leq 3833 \text{ Nm}$

14PC32	19FC14	19FC30	19JC14	19JC30	19PC14	19PC30	GFL11-2S			
...S00	...S00	...S00	...S00	...S00	...S00	...S00	M_1	J_G	M_{2GN}	i
21	27	21	40	29	51	32	n_1			
3225	1425	3000	1425	3000	1350	3000	I_{M400}			
15.6	8.6	14	12.3	18.5	14.3	19	P_N			
7.1	4	6.6	6	9.1	7.2	10	J_M			
34.82	65.12	65.04	105.04	105.12	160.12	160.04	M_2			
1440							c			
1.7							$n_{2 \text{ Eck}}$	5.72	2588	71.2
45							$n_{2 \text{ th}}$			
45							M_2			
1621							c			
1.4							$n_{2 \text{ Eck}}$	3.87	2325	79.875
40							$n_{2 \text{ th}}$			
40							M_2			
1826							c			
1.4							$n_{2 \text{ Eck}}$	3.76	2620	90
36							$n_{2 \text{ th}}$			
36										

M ... [Nm]
n ... [min⁻¹]
J ... [kgcm²]

P ... [kW]
I ... [A]
i [-]
c [-]

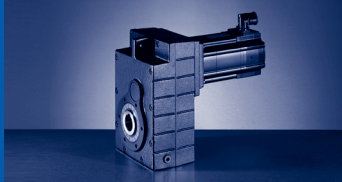

GFL [Nm]

GFL□□-□S (MCS)

$M_{2GN} \leq 5950 \text{ Nm}$

GFL11-3S				09DC41	09FC38	09HC41	09LC41	12DC20	12DC41	12HC15	12HC30	12HC35	12LC20	12LC41	14DC15	
				...500	...500	...500	...500	...500	...500	...500	...500	...500	...500	...500	...500	
i	M_{2GN}	J_G	M_1	2.3	3.1	3.8	4.5	5.5	4.3	10	8	7.5	13.5	11	9.2	
			n_1	4050	3750	4050	4050	1950	4050	1500	3000	3525	1950	4050	1500	
			I_{M230}	4.6	5	6.8	8.4	5.2	8.8	7.6	10.5		11.8			
			I_{M400}	2.3	2.5	3.4	4.2	2.6	4.5	3.8		5.7	5.9	10.2	4.5	
			P_N	1	1.2	1.6	1.9	1.1	1.8	1.6	2.5	2.8	2.8	4.7	1.45	
			J_M	1.13	1.53	1.93	2.83	4.12	4.12	7.42	7.42	7.42	10.72	10.72	8.22	
65.306	2503	6.97	M_2							604	478	448	825	670		
			c							4	5	5.1	3	3.3		
			$n_{2 \text{ Eck}}$								23	46	54	30	62	
			$n_{2 \text{ th}}$								23	46	54	30	62	
65.306	2891	6.97	M_2												550	
			c												5	
			$n_{2 \text{ Eck}}$													23
			$n_{2 \text{ th}}$													23
73.335	2875	7.84	M_2							678	536	503	926	752	621	
			c							4.1	5.1	5.2	3	3.4	4.5	
			$n_{2 \text{ Eck}}$								21	41	48	27	55	21
			$n_{2 \text{ th}}$								20	41	48	27	48	20
82.631	3240	7.71	M_2							764	604	566	1043	847	700	
			c							4.1	5.1	5.2	3	3.4	4.5	
			$n_{2 \text{ Eck}}$								18	36	43	24	49	18
			$n_{2 \text{ th}}$								18	36	43	24	43	18
93.54	3206	5.05	M_2							870	689	646	1186	963	797	
			c							3.6	4.5	4.5	2.7	3	3.9	
			$n_{2 \text{ Eck}}$								16	32	38	21	43	16
			$n_{2 \text{ th}}$								16	32	38	21	43	16
105.397	3613	4.97	M_2							980	776	728	1336	1085	899	
			c							3.6	4.5	4.5	2.7	3	3.9	
			$n_{2 \text{ Eck}}$								14	29	34	19	38	14
			$n_{2 \text{ th}}$								14	28	33	19	38	14
114.586	3501	3.71	M_2					572		1070	849	795	1457	1184	981	
			c					5.8		3.2	4	4	2.4	2.6	3.5	
			$n_{2 \text{ Eck}}$					17		13	26	31	17	35	13	
			$n_{2 \text{ th}}$					17		13	26	31	17	35	13	
129.111	3945	3.66	M_2					644		1206	956	896	1642	1334	1106	
			c					5.8		3.2	4	4	2.4	2.6	3.5	
			$n_{2 \text{ Eck}}$					15		12	23	27	15	31	12	
			$n_{2 \text{ th}}$					15		12	23	27	15	31	12	
149.144	3063	2.3	M_2			518	619									
			c			5.1	4.3									
			$n_{2 \text{ Eck}}$			27	27									
			$n_{2 \text{ th}}$			27	27									
149.144	3894	2.3	M_2					751	582	1399	1111	1042	1904	1547	1284	
			c					5	5.8	2.7	3.4	3.5	2	2.3	3	
			$n_{2 \text{ Eck}}$					13	27	10	20	24	13	27	10	
			$n_{2 \text{ th}}$					13	27	10	20	24	13	27	10	
168.049	3451	2.27	M_2			584	698									
			c			5.1	4.3									
			$n_{2 \text{ Eck}}$			24	24									
			$n_{2 \text{ th}}$			24	24									
168.049	4387	2.27	M_2					847	656	1577	1252	1174	2145	1744	1447	
			c					5	5.8	2.7	3.4	3.5	2	2.3	3	
			$n_{2 \text{ Eck}}$					12	24	9	18	21	12	24	9	
			$n_{2 \text{ th}}$					12	24	9	18	21	12	24	9	
182.792	3211	1.66	M_2		516	640	764									
			c		5.5	4.4	3.7									
			$n_{2 \text{ Eck}}$		21	22	22									
			$n_{2 \text{ th}}$		21	22	22									

$M \dots$ [Nm]
 $n \dots$ [min^{-1}]
 $J \dots$ [kgcm^2]

$P \dots$ [kW]
 $I \dots$ [A]
 $i \dots$ [-]
 $c \dots$ [-]

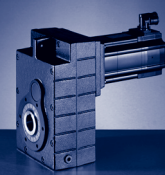

$M_{2GN} \leq 5950 \text{ Nm}$

14DC36	14HC15	14HC32	14LC15	14LC32	14PC14	14PC32	19FC14	19FC30	19JC14	19JC30	19PC30	GFL11-3S			
...500	...500	...500	...500	...500	...500	...500	...500	...500	...500	...500	...500	M_1	J_G	M_{2GN}	i
7.5	16	14	23	17.2	30	21	27	21	40	29	32	n_1			
3600	1500	3225	1500	3225	1350	3225	1425	3000	1425	3000	3000	I_{M230}			
												I_{M400}			
7.5	6.6	11.9	9.7	15	10.8	15.6	8.6	14	12.3	18.5	19	P_N			
2.8	2.5	4.7	3.6	5.8	4.2	7.1	4	6.6	6	9.1	10	J_M			
8.22	14.32	14.32	23.44	23.44	34.74	34.82	65.12	65.04	105.04	105.12	160.04	M_2			
												c			
												n_2 Eck	6.97	2503	65.306
												n_2 th			
445	979	853	1420	1055	1862	1295						M_2			
5.8	2.9	3.2	2	2.6	1.5	2.2						c			
55	23	49	23	49	21	49						n_2 Eck	6.97	2891	65.306
55	23	49	23	49	21	49						n_2 th			
503	1103	962	1599	1189	2094	1458	1882	1457	2803	2024	2236	M_2			
5.2	2.6	2.9	1.8	2.3	1.4	1.9	1.5	2	1	1.4	1.3	c			
49	21	44	21	44	18	44	19	41	19	41	41	n_2 Eck	7.84	2875	73.335
49	20	44	20	44	18	42	19	30	19	30	30	n_2 th			
567	1243	1084	1801	1339	2360	1643	2121	1642	3158	2280	2520	M_2			
5.2	2.6	2.9	1.8	2.3	1.4	1.9	1.5	2	1	1.4	1.3	c			
44	18	39	18	39	16	39	17	36	17	36	36	n_2 Eck	7.71	3240	82.631
43	18	39	18	39	16	37	17	27	17	27	27	n_2 th			
646	1412	1232	2044	1521	2676	1864						M_2			
4.5	2.2	2.5	1.6	2	1.2	1.7						c			
39	16	35	16	35	14	35						n_2 Eck	5.05	3206	93.54
38	16	34	16	34	14	34						n_2 th			
728	1591	1388	2303	1714	3016	2100						M_2			
4.5	2.2	2.5	1.6	2	1.2	1.7						c			
34	14	31	14	31	13	31						n_2 Eck	4.97	3613	105.397
34	14	31	14	31	13	31						n_2 th			
795	1734	1513	2508	1867	3283	2288						M_2			
4	2	2.2	1.4	1.8	1.1	1.5						c			
31	13	28	13	28	12	28						n_2 Eck	3.71	3501	114.586
31	13	28	13	28	12	28						n_2 th			
896	1954	1705	2826	2104	3699	2578						M_2			
4	2	2.2	1.4	1.8	1.1	1.5						c			
28	12	25	12	25	11	25						n_2 Eck	3.66	3945	129.111
28	12	25	12	25	10	25						n_2 th			
												M_2			
												c			
												n_2 Eck	2.3	3063	149.144
												n_2 th			
1042	2264	1977	3272	2437		2985						M_2			
3.4	1.7	1.9	1.2	1.6		1.3						c			
24	10	22	10	22		22						n_2 Eck	2.3	3894	149.144
24	10	22	10	22		22						n_2 th			
												M_2			
												c			
												n_2 Eck	2.27	3451	168.049
												n_2 th			
1174	2551	2227	3687	2746		3363						M_2			
3.4	1.7	1.9	1.2	1.6		1.3						c			
21	9	19	9	19		19						n_2 Eck	2.27	4387	168.049
21	9	19	9	19		19						n_2 th			
												M_2			
												c			
												n_2 Eck	1.66	3211	182.792
												n_2 th			

$M \dots$ [Nm]
 $n \dots$ [min^{-1}]
 $J \dots$ [kgcm^2]

$P \dots$ [kW]
 $I \dots$ [A]
 $i [-]$
 $c [-]$

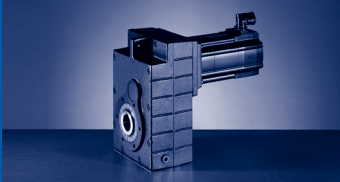

GFL [Nm]

GFL□□-□S (MCS)

$M_{2GN} \leq 5950 \text{ Nm}$

GFL11-3S				09DC41	09FC38	09HC41	09LC41	12DC20	12DC41	12HC15	12HC30	12HC35	12LC20	12LC41	14DC15
				...500	...500	...500	...500	...500	...500	...500	...500	...500	...500	...500	...500
i	M_{2GN}	J_G	M_1	2.3	3.1	3.8	4.5	5.5	4.3	10	8	7.5	13.5	11	9.2
			n_1	4050	3750	4050	4050	1950	4050	1500	3000	3525	1950	4050	1500
			I_{M230}	4.6	5	6.8	8.4	5.2	8.8	7.6	10.5		11.8		
			I_{M400}	2.3	2.5	3.4	4.2	2.6	4.5	3.8		5.7	5.9	10.2	4.5
			P_N	1	1.2	1.6	1.9	1.1	1.8	1.6	2.5	2.8	2.8	4.7	1.45
			J_M	1.13	1.53	1.93	2.83	4.12	4.12	7.42	7.42	7.42	10.72	10.72	8.22
182.792	4131	1.66	M_2					928	720	1722	1369	1283	2340	1903	
			c				4.3	5	2.4	3	3	1.8	2		
			$n_{2 \text{ Eck}}$				11	22	8	16	19	11	22		
			$n_{2 \text{ th}}$				11	22	8	16	19	11	22		
182.792	4233	1.66	M_2												1580
			c												2.6
			$n_{2 \text{ Eck}}$												8
			$n_{2 \text{ th}}$												8
205.963	3618	1.64	M_2		581	722	861								
			c		5.5	4.4	3.7								
			$n_{2 \text{ Eck}}$		18	20	20								
			$n_{2 \text{ th}}$		18	20	20								
205.963	4655	1.64	M_2					1045	811	1940	1542	1446	2636	2144	
			c					4.3	5	2.4	3	3	1.8	2	
			$n_{2 \text{ Eck}}$					10	20	7	15	17	10	20	
			$n_{2 \text{ th}}$					9	20	7	15	17	9	20	
205.963	4769	1.64	M_2												1780
			c												2.6
			$n_{2 \text{ Eck}}$												7
			$n_{2 \text{ th}}$												7
224.636	3946	1.52	M_2		634	787	939								
			c		5.5	4.4	3.7								
			$n_{2 \text{ Eck}}$		17	18	18								
			$n_{2 \text{ th}}$		17	18	18								
224.636	4523	1.52	M_2					1146	890	2122	1688	1582	2881	2343	1948
			c					3.8	4.4	2.1	2.6	2.7	1.6	1.7	2.3
			$n_{2 \text{ Eck}}$					9	18	7	13	16	9	18	7
			$n_{2 \text{ th}}$					9	18	7	13	16	9	18	7
253.111	4446	1.5	M_2		715	887	1058								
			c		5.5	4.4	3.7								
			$n_{2 \text{ Eck}}$		15	16	16								
			$n_{2 \text{ th}}$		15	16	16								
253.111	5097	1.5	M_2					1291	1003	2391	1902	1783	3246	2640	2195
			c					3.8	4.4	2.1	2.6	2.7	1.6	1.7	2.3
			$n_{2 \text{ Eck}}$					8	16	6	12	14	8	16	6
			$n_{2 \text{ th}}$					8	16	6	12	14	8	16	6
267.259	5106	1.87	M_2		750	932	1113	1366	1061	2527	2011	1885	3431	2791	2321
			c		6	4.8	4	3.6	4.2	2	2.5	2.5	1.5	1.6	2.2
			$n_{2 \text{ Eck}}$		14	15	15	7	15	6	11	13	7	15	6
			$n_{2 \text{ th}}$		14	15	15	7	15	6	11	13	7	15	6
327.556	5523	1.37	M_2		927	1150	1371	1682	1308	3105	2473	2318	4212	3427	2852
			c		5.3	4.2	3.6	3.2	3.7	1.8	2.2	2.2	1.3	1.5	1.9
			$n_{2 \text{ Eck}}$		12	12	12	6	12	5	9	11	6	12	5
			$n_{2 \text{ th}}$		11	12	12	6	12	5	9	11	6	12	5
358.077	4103	0.68	M_2	756	1032	1275	1517								
			c	4.7	3.6	2.9	2.4								
			$n_{2 \text{ Eck}}$	11	11	11	11								
			$n_{2 \text{ th}}$	11	10	11	11								
358.077	5280	0.68	M_2					1847	1437	3403	2711	2541	4613	3754	
			c					2.8	3.3	1.5	1.9	2	1.1	1.3	
			$n_{2 \text{ Eck}}$					6	11	4	8	10	6	11	
			$n_{2 \text{ th}}$					5	11	4	8	10	5	11	

$M \dots [\text{Nm}]$
 $n \dots [\text{min}^{-1}]$
 $J \dots [\text{kgcm}^2]$

$P \dots [\text{kW}]$
 $I \dots [\text{A}]$
 $i \dots [-]$
 $c \dots [-]$

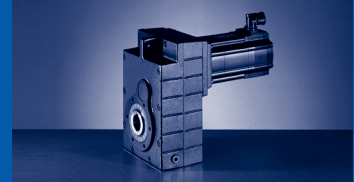

$M_{2GN} \leq 5950 \text{ Nm}$

14DC36	14HC15	14HC32	14LC15	14LC32	14PC14	14PC32	19FC14	19FC30	19JC14	19JC30	19PC30	GFL11-3S			
...500	...500	...500	...500	...500	...500	...500	...500	...500	...500	...500	...500	M_1	J_G	M_{2GN}	i
7.5	16	14	23	17.2	30	21	27	21	40	29	32	n_1			
3600	1500	3225	1500	3225	1350	3225	1425	3000	1425	3000	3000	I_{M230}			
												I_{M400}			
7.5	6.6	11.9	9.7	15	10.8	15.6	8.6	14	12.3	18.5	19	P_N			
2.8	2.5	4.7	3.6	5.8	4.2	7.1	4	6.6	6	9.1	10	J_M			
8.22	14.32	14.32	23.44	23.44	34.74	34.82	65.12	65.04	105.04	105.12	160.04	M_2			
												c			
												n_2 Eck	1.66	4131	182.792
												n_2 th			
1282	2780	2428	4016	2993		3664						M_2			
3	1.5	1.7	1.1	1.4		1.1						c	1.66	4233	182.792
20	8	18	8	18		18						n_2 Eck			
20	8	18	8	18		18						n_2 th			
												M_2			
												c	1.64	3618	205.963
												n_2 Eck			
												n_2 th			
												M_2			
												c	1.64	4655	205.963
												n_2 Eck			
												n_2 th			
1445	3132	2736	4525	3372		4128						M_2			
3	1.5	1.7	1.1	1.4		1.1						c	1.64	4769	205.963
18	7	16	7	16		16						n_2 Eck			
17	7	16	7	16		16						n_2 th			
												M_2			
												c	1.52	3946	224.636
												n_2 Eck			
												n_2 th			
1582	3423	2991		3685								M_2			
2.6	1.3	1.5		1.2								c	1.52	4523	224.636
16	7	14		14								n_2 Eck			
16	7	14		14								n_2 th			
												M_2			
												c	1.5	4446	253.111
												n_2 Eck			
												n_2 th			
1783	3857	3370		4152								M_2			
2.6	1.3	1.5		1.2								c	1.5	5097	253.111
14	6	13		13								n_2 Eck			
14	6	13		13								n_2 th			
1885	4076	3561		4387								M_2			
2.5	1.3	1.4		1.1								c	1.87	5106	267.259
14	6	12		12								n_2 Eck			
13	6	12		12								n_2 th			
2318	5003	4372		5384								M_2			
2.2	1.1	1.2		1								c	1.37	5523	327.556
11	5	10		10								n_2 Eck			
11	5	10		10								n_2 th			
												M_2			
												c	0.68	4103	358.077
												n_2 Eck			
												n_2 th			
												M_2			
												c	0.68	5280	358.077
												n_2 Eck			
												n_2 th			

$M \dots$ [Nm]
 $n \dots$ [min^{-1}]
 $J \dots$ [kgcm^2]

$P \dots$ [kW]
 $I \dots$ [A]
 i [-]
 c [-]

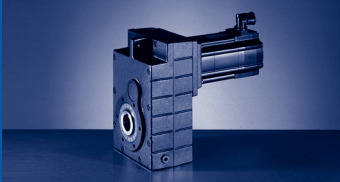

GFL [Nm]

GFL□□-□S (MCS)

$M_{2GN} \leq 5950 \text{ Nm}$

GFL11-3S				09DC41	09FC38	09HC41	09LC41	12DC20	12DC41	12HC15	12HC30	12HC35	12LC20	12LC41	14DC15			
				...500	...500	...500	...500	...500	...500	...500	...500	...500	...500	...500	...500			
i	M_{2GN}	J_G	M_1	2.3	3.1	3.8	4.5	5.5	4.3	10	8	7.5	13.5	11	9.2			
			n_1	4050	3750	4050	4050	1950	4050	1500	3000	3525	1950	4050	1500			
			I_{M230}	4.6	5	6.8	8.4	5.2	8.8	7.6	10.5		11.8					
			I_{M400}	2.3	2.5	3.4	4.2	2.6	4.5	3.8		5.7	5.9	10.2	4.5			
			P_N	1	1.2	1.6	1.9	1.1	1.8	1.6	2.5	2.8	2.8	4.7	1.45			
			J_M	1.13	1.53	1.93	2.83	4.12	4.12	7.42	7.42	7.42	10.72	10.72	8.22			
403.467	4623	0.67	M_2	852	1163	1437	1710											
			c	4.7	3.6	2.9	2.4											
			$n_{2 \text{ Eck}}$	10	9	10	10											
			$n_{2 \text{ th}}$	10	9	10	10											
403.467	5950	0.67	M_2					2081	1619	3834	3055	2863	5198	4229				
			c					2.8	3.3	1.5	1.9	2	1.1	1.3				
			$n_{2 \text{ Eck}}$					5	10	4	7	9	5	10				
			$n_{2 \text{ th}}$					5	10	4	7	9	5	10				
430.222	5912	0.85	M_2	900	1230	1523	1814											
			c	5.7	4.3	3.4	2.9											
			$n_{2 \text{ Eck}}$	9	9	9	9											
			$n_{2 \text{ th}}$	9	9	9	9											
430.222	5942	0.85	M_2					2223	1730	4092	3261	3057	5546	4514				
			c					2.6	3	1.5	1.8	1.8	1.1	1.2				
			$n_{2 \text{ Eck}}$					5	9	4	7	8	5	9				
			$n_{2 \text{ th}}$					5	9	3	7	8	5	9				
522.133	5942	0.62	M_2	1103	1505	1860	2213	2711	2112	4980	3972	3723						
			c	4.7	3.6	2.8	2.4	2.2	2.5	1.2	1.5	1.5						
			$n_{2 \text{ Eck}}$	8	7	8	8	4	8	3	6	7						
			$n_{2 \text{ th}}$	8	7	8	8	4	8	3	6	7						
562.391	5319	0.6	M_2	1199	1632	2013	2394	2931	2285		4289	4020						
			c	3.9	3	2.4	2	1.8	2.1		1.2	1.3						
			$n_{2 \text{ Eck}}$	7	7	7	7	4	7		5	6						
			$n_{2 \text{ th}}$	7	7	7	7	3	7		5	6						
633.68	5844	0.6	M_2	1352	1840	2270	2698	3304	2576		4834	4532						
			c	3.8	2.9	2.3	1.9	1.8	2		1.2	1.2						
			$n_{2 \text{ Eck}}$	6	6	6	6	3	6		5	6						
			$n_{2 \text{ th}}$	6	6	6	6	3	6		5	6						
710.888	5319	0.39	M_2	1529	2076	2558	3039											
			c	3.1	2.4	1.9	1.6											
			$n_{2 \text{ Eck}}$	6	5	6	6											
			$n_{2 \text{ th}}$	6	5	6	6											
801	5844	0.38	M_2	1724	2341	2884	3425											
			c	3	2.3	1.8	1.5											
			$n_{2 \text{ Eck}}$	5	5	5	5											
			$n_{2 \text{ th}}$	5	5	5	5											

$M \dots$ [Nm]
 $n \dots$ [min^{-1}]
 $J \dots$ [kgcm^2]

$P \dots$ [kW]
 $I \dots$ [A]
 i [-]
 c [-]

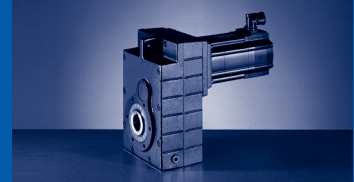

$M_{2GN} \leq 5950 \text{ Nm}$

14DC36	14HC15	14HC32	14LC15	14LC32	14PC14	14PC32	19FC14	19FC30	19JC14	19JC30	19PC30	GFL11-3S			
...500	...500	...500	...500	...500	...500	...500	...500	...500	...500	...500	...500	M_1	J_G	M_{2GN}	i
7.5	16	14	23	17.2	30	21	27	21	40	29	32	n_1			
3600	1500	3225	1500	3225	1350	3225	1425	3000	1425	3000	3000	n_1			
												I_{M230}			
7.5	6.6	11.9	9.7	15	10.8	15.6	8.6	14	12.3	18.5	19	I_{M400}			
2.8	2.5	4.7	3.6	5.8	4.2	7.1	4	6.6	6	9.1	10	P_N			
8.22	14.32	14.32	23.44	23.44	34.74	34.82	65.12	65.04	105.04	105.12	160.04	J_M			
												M_2			
												c	0.67	4623	403.467
												$n_{2 \text{ Eck}}$			
												$n_{2 \text{ th}}$			
												M_2	0.67	5950	403.467
												c			
												$n_{2 \text{ Eck}}$			
												$n_{2 \text{ th}}$			
												M_2	0.85	5912	430.222
												c			
												$n_{2 \text{ Eck}}$			
												$n_{2 \text{ th}}$			
												M_2	0.85	5942	430.222
												c			
												$n_{2 \text{ Eck}}$			
												$n_{2 \text{ th}}$			
												M_2	0.62	5942	522.133
												c			
												$n_{2 \text{ Eck}}$			
												$n_{2 \text{ th}}$			
												M_2	0.6	5319	562.391
												c			
												$n_{2 \text{ Eck}}$			
												$n_{2 \text{ th}}$			
												M_2	0.6	5844	633.68
												c			
												$n_{2 \text{ Eck}}$			
												$n_{2 \text{ th}}$			
												M_2	0.39	5319	710.888
												c			
												$n_{2 \text{ Eck}}$			
												$n_{2 \text{ th}}$			
												M_2	0.38	5844	801
												c			
												$n_{2 \text{ Eck}}$			
												$n_{2 \text{ th}}$			

M ... [Nm]
n ... [min⁻¹]
J ... [kgcm²]

P ... [kW]
I ... [A]
i [-]
c [-]

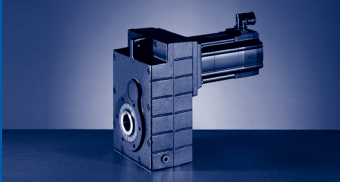

GFL [Nm]

GFL□□-□S (MCS)

$M_{2GN} \leq 4971 \text{ Nm}$

GFL14-2S				19FC14	19FC30	19JC14	19JC30	19PC14	19PC30	
				...500	...500	...500	...500	...500	...500	
i	M_{2GN}	J_G	M_1	27	21	40	29	51	32	
			n_1	1425	3000	1425	3000	1350	3000	
			I_{M400}	8.6	14	12.3	18.5	14.3	19	
			P_N	4	6.6	6	9.1	7.2	10	
			J_M	65.12	65.04	105.04	105.12	160.12	160.04	
8.8	2033	247	M_2			324		419	259	
			c			6		4.7	5.9	
			n_2 Eck			162		153		341
			n_2 th			162		153		194
9.571	2211	232	M_2			352		456	282	
			c			6		4.7	5.9	
			n_2 Eck			149		141		313
			n_2 th			149		141		178
14.2	3280	625	M_2			523		676	419	
			c			6		4.7	5.9	
			n_2 Eck			100		95		211
			n_2 th			100		95		120
15.62	3389	156	M_2			578		746	462	
			c			5.6		4.4	5.6	
			n_2 Eck			91		86		192
			n_2 th			91		86		111
17.6	3818	146	M_2			651		840	521	
			c			5.6		4.4	5.6	
			n_2 Eck			81		77		171
			n_2 th			81		77		99
19.948	3646	111	M_2			745	537	960	596	
			c			4.7	5.2	3.7	4.7	
			n_2 Eck			71	150	68	150	
			n_2 th			71	99	68	97	
22.476	4108	105	M_2			839	605	1081	671	
			c			4.7	5.2	3.7	4.7	
			n_2 Eck			63	134	60	134	
			n_2 th			63	88	60	86	
24.456	3842	83.2	M_2	608		919	659	1183	731	
			c	6		4.1	5	3.2	4.6	
			n_2 Eck	58		58	123	55	123	
			n_2 th	58		58	90	55	89	
27.556	4328	79.4	M_2	685		1036	743	1333	824	
			c	6		4.1	5	3.2	4.6	
			n_2 Eck	52		52	109	49	109	
			n_2 th	52		52	80	49	79	
32.344	4045	52.9	M_2	814	628	1227	882	1575	977	
			c	4.8	5.5	3.2	4	2.5	3.6	
			n_2 Eck	44	93	44	93	42	93	
			n_2 th	44	68	44	68	42	68	
36.444	4558	50.7	M_2	918	708	1382	994	1775	1101	
			c	4.8	5.5	3.2	4	2.5	3.6	
			n_2 Eck	39	82	39	82	37	82	
			n_2 th	39	61	39	61	37	61	
39.642	4238	38	M_2	1005	777	1511	1087	1938	1204	
			c	4.1	4.7	2.8	3.4	2.2	3.1	
			n_2 Eck	36	76	36	76	34	76	
			n_2 th	36	56	36	56	34	56	
44.667	4776	36.6	M_2	1133	875	1702	1225	2184	1357	
			c	4.1	4.7	2.8	3.4	2.2	3.1	
			n_2 Eck	32	67	32	67	30	67	
			n_2 th	32	49	32	49	30	49	

$M \dots$ [Nm]
 $n \dots$ [min^{-1}]
 $J \dots$ [kgcm^2]

$P \dots$ [kW]
 $I \dots$ [A]
 i [-]
 c [-]

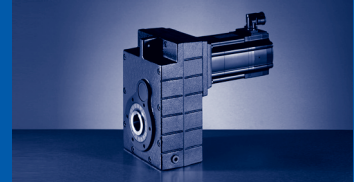

$M_{2GN} \leq 4971 \text{ Nm}$

GFL14-2S				19FC14	19FC30	19JC14	19JC30	19PC14	19PC30
				...500	...500	...500	...500	...500	...500
i	M_{2GN}	J_G	M_1	27	21	40	29	51	32
			n_1	1425	3000	1425	3000	1350	3000
			I_{M400}	8.6	14	12.3	18.5	14.3	19
			P_N	4	6.6	6	9.1	7.2	10
			J_M	65.12	65.04	105.04	105.12	160.12	160.04
52.067	4358	24.6	M_2	1333	1031	1997	1440	2558	1593
			c	3.2	3.7	2.2	2.7	1.7	2.4
			$n_{2 \text{ Eck}}$	27	58	27	58	26	58
			$n_{2 \text{ th}}$	27	42	27	42	26	42
58.667	4911	23.8	M_2	1502	1162	2250	1622	2882	1795
			c	3.2	3.7	2.2	2.7	1.7	2.4
			$n_{2 \text{ Eck}}$	24	51	24	51	23	51
			$n_{2 \text{ th}}$	24	38	24	38	23	38
63.19	4412	18	M_2	1627	1260	2432	1755	3113	1941
			c	2.7	3.1	1.8	2.2	1.4	2
			$n_{2 \text{ Eck}}$	23	48	23	48	21	48
			$n_{2 \text{ th}}$	23	35	23	35	21	35
71.2	4971	17.4	M_2	1833	1414	2740	1973	3508	2182
			c	2.7	3.4	1.8	2.5	1.4	2.3
			$n_{2 \text{ Eck}}$	20	42	20	42	19	42
			$n_{2 \text{ th}}$	20	31	20	31	19	31

M ... [Nm]
n ... [min^{-1}]
J ... [kgcm^2]

P ... [kW]
I ... [A]
i [-]
c [-]

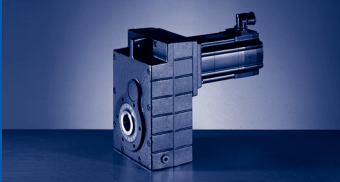

GFL [Nm]

GFL□□-□S (MCS)

$M_{2GN} \leq 11496 \text{ Nm}$

GFL14-3S				12DC20	12DC41	12HC15	12HC30	12HC35	12LC20	12LC41	14DC15	14DC36	14HC15
				...500	...500	...500	...500	...500	...500	...500	...500	...500	...500
i	M_{2GN}	J_G	M_1	5.5	4.3	10	8	7.5	13.5	11	9.2	7.5	16
			n_1	1950	4050	1500	3000	3525	1950	4050	1500	3600	1500
			I_{M230}	5.2	8.8	7.6	10.5		11.8				
			I_{M400}	2.6	4.5	3.8		5.7	5.9	10.2	4.5	7.5	6.6
			P_N	1.1	1.8	1.6	2.5	2.8	2.8	4.7	1.45	2.8	2.5
			J_M	4.12	4.12	7.42	7.42	7.42	10.72	10.72	8.22	8.22	14.32
64.296	5534	26.32	M_2										936
			c										5.6
			$n_{2 \text{ Eck}}$										23
			$n_{2 \text{ th}}$										23
64.296	5610	26.32	M_2										
			c										
			$n_{2 \text{ Eck}}$										
			$n_{2 \text{ th}}$										
68.708	3311	19.86	M_2			629			861	699			
			c			5			3.7	4.2			
			$n_{2 \text{ Eck}}$			22			28	59			
			$n_{2 \text{ th}}$			22			28	52			
68.708	5182	19.86	M_2										1007
			c										4.9
			$n_{2 \text{ Eck}}$										22
			$n_{2 \text{ th}}$										22
68.708	5416	19.86	M_2										
			c										
			$n_{2 \text{ Eck}}$										
			$n_{2 \text{ th}}$										
77.418	3730	19.38	M_2			709			970	787			
			c			5			3.7	4.2			
			$n_{2 \text{ Eck}}$			19			25	52			
			$n_{2 \text{ th}}$			19			25	46			
77.418	5839	19.38	M_2										1135
			c										4.9
			$n_{2 \text{ Eck}}$										19
			$n_{2 \text{ th}}$										19
77.418	6103	19.38	M_2										
			c										
			$n_{2 \text{ Eck}}$										
			$n_{2 \text{ th}}$										
85.037	6276	21.59	M_2										1248
			c										4.8
			$n_{2 \text{ Eck}}$										18
			$n_{2 \text{ th}}$										18
104.889	3398	9.32	M_2			977	775	726	1332	1082			
			c			3.4	4.2	4.3	2.5	2.8			
			$n_{2 \text{ Eck}}$			14	29	34	19	39			
			$n_{2 \text{ th}}$			14	29	34	19	39			
104.889	5307	9.32	M_2								876		1565
			c								5.8		3.3
			$n_{2 \text{ Eck}}$								14		14
			$n_{2 \text{ th}}$								14		14
114.126	3697	8.32	M_2			1063	843	790	1449	1177			
			c			3.4	4.2	4.3	2.5	2.8			
			$n_{2 \text{ Eck}}$			13	26	31	17	36			
			$n_{2 \text{ th}}$			13	26	31	17	35			
114.126	5774	8.32	M_2								953		1703
			c								5.8		3.3
			$n_{2 \text{ Eck}}$								13		13
			$n_{2 \text{ th}}$								13		13

$M \dots$ [Nm]
 $n \dots$ [min^{-1}]
 $J \dots$ [kgcm^2]

$P \dots$ [kW]
 $I \dots$ [A]
 $i \dots$ [-]
 $c \dots$ [-]

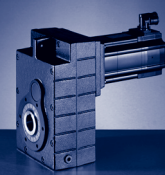

$M_{2GN} \leq 11496 \text{ Nm}$

14HC32	14LC15	14LC32	14PC14	14PC32	19FC14	19FC30	19JC14	19JC30	19PC14	19PC30	GFL14-3S			
...500	...500	...500	...500	...500	...500	...500	...500	...500	...500	...500	M_1	J_G	M_{2GN}	i
14	23	17.2	30	21	27	21	40	29	51	32	n_1			
3225	1500	3225	1350	3225	1425	3000	1425	3000	1350	3000	I_{M230}			
											I_{M400}			
11.9	9.7	15	10.8	15.6	8.6	14	12.3	18.5	14.3	19	P_N			
4.7	3.6	5.8	4.2	7.1	4	6.6	6	9.1	7.2	10	J_M			
14.32	23.44	23.44	34.74	34.82	65.12	65.04	105.04	105.12	160.12	160.04	M_2			
818	1370	1017	1805	1253							c	26.32	5534	64.296
5.7	3.9	4.6	3	3.8							$n_{2 \text{ Eck}}$			
50	23	50	21	50							$n_{2 \text{ th}}$			
50	23	50	21	48										
					1618	1251	2425	1748	3108	1934	M_2			
					3.4	3.9	2.3	2.8	1.8	2.6	c	26.32	5610	64.296
					22	47	22	47	21	47	$n_{2 \text{ Eck}}$			
					22	34	22	34	21	34	$n_{2 \text{ th}}$			
											M_2			
											c	19.86	3311	68.708
											$n_{2 \text{ Eck}}$			
											$n_{2 \text{ th}}$			
876	1472	1088	1936	1340							M_2			
5.5	3.4	4.5	2.6	3.7							c	19.86	5182	68.708
47	22	47	20	47							$n_{2 \text{ Eck}}$			
47	22	47	20	47							$n_{2 \text{ th}}$			
					1735	1337	2597	1867	3327	2067	M_2			
					3.1	3.9	2.1	2.8	1.6	2.6	c	19.86	5416	68.708
					21	44	21	44	20	44	$n_{2 \text{ Eck}}$			
					21	32	21	32	20	32	$n_{2 \text{ th}}$			
											M_2			
											c	19.38	3730	77.418
											$n_{2 \text{ Eck}}$			
											$n_{2 \text{ th}}$			
987	1658	1226	2182	1510							M_2			
5.5	3.4	4.5	2.6	3.7							c	19.38	5839	77.418
42	19	42	17	42							$n_{2 \text{ Eck}}$			
42	19	42	17	42							$n_{2 \text{ th}}$			
					1955	1506	2927	2104	3749	2328	M_2			
					3.1	3.9	2.1	2.8	1.6	2.6	c	19.38	6103	77.418
					18	39	18	39	17	39	$n_{2 \text{ Eck}}$			
					18	29	18	29	17	29	$n_{2 \text{ th}}$			
1086	1823	1348	2398	1660	2152	1659	3219	2316	4122	2562	M_2			
5.4	3.4	4.4	2.6	3.6	2.9	3.7	1.9	2.7	1.5	2.4	c	21.59	6276	85.037
38	18	38	16	38	17	35	17	35	16	35	$n_{2 \text{ Eck}}$			
38	18	37	16	36	17	26	17	26	16	26	$n_{2 \text{ th}}$			
											M_2			
											c	9.32	3398	104.889
											$n_{2 \text{ Eck}}$			
											$n_{2 \text{ th}}$			
1364	2274	1688	2983	2073							M_2			
3.7	2.3	3	1.8	2.5							c	9.32	5307	104.889
31	14	31	13	31							$n_{2 \text{ Eck}}$			
31	14	31	13	31							$n_{2 \text{ th}}$			
											M_2			
											c	8.32	3697	114.126
											$n_{2 \text{ Eck}}$			
											$n_{2 \text{ th}}$			
1484	2474	1837	3246	2255							M_2			
3.7	2.3	3	1.8	2.5							c	8.32	5774	114.126
28	13	28	12	28							$n_{2 \text{ Eck}}$			
28	13	28	12	28							$n_{2 \text{ th}}$			

$M \dots$ [Nm]
 $n \dots$ [min^{-1}]
 $J \dots$ [kgcm^2]

$P \dots$ [kW]
 $I \dots$ [A]
 $i [-]$
 $c [-]$

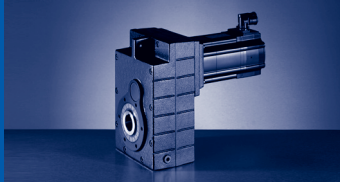

GFL [Nm]

GFL□□-□S (MCS)

$M_{2GN} \leq 11496 \text{ Nm}$

GFL14-3S				12DC20	12DC41	12HC15	12HC30	12HC35	12LC20	12LC41	14DC15	14DC36	14HC15
				...500	...500	...500	...500	...500	...500	...500	...500	...500	...500
i	M_{2GN}	J_G	M_1	5.5	4.3	10	8	7.5	13.5	11	9.2	7.5	16
			n_1	1950	4050	1500	3000	3525	1950	4050	1500	3600	1500
			I_{M230}	5.2	8.8	7.6	10.5		11.8				
			I_{M400}	2.6	4.5	3.8		5.7	5.9	10.2	4.5	7.5	6.6
			P_N	1.1	1.8	1.6	2.5	2.8	2.8	4.7	1.45	2.8	2.5
			J_M	4.12	4.12	7.42	7.42	7.42	10.72	10.72	8.22	8.22	14.32
128.593	4166	8.14	M_2			1198	950	890	1633	1327			
			c			3.4	4.2	4.3	2.5	2.8			
			$n_{2 \text{ Eck}}$			12	23	27	15	32			
			$n_{2 \text{ th}}$			12	23	27	15	31			
128.593	6506	8.14	M_2								1074		1919
			c								5.8		3.3
			$n_{2 \text{ Eck}}$								12		12
			$n_{2 \text{ th}}$								12		12
136.889	7359	16.78	M_2										2038
			c										3.5
			$n_{2 \text{ Eck}}$										11
			$n_{2 \text{ th}}$										11
156.148	4335	5.92	M_2	784		1463	1161	1088	1990	1618			
			c	5.3		2.9	3.6	3.7	2.2	2.4			
			$n_{2 \text{ Eck}}$	13		10	19	23	13	26			
			$n_{2 \text{ th}}$	12		10	19	23	12	26			
156.148	6760	5.92	M_2								1317	1064	2342
			c								4.9	5.7	2.8
			$n_{2 \text{ Eck}}$								10	23	10
			$n_{2 \text{ th}}$								10	23	10
170.074	5510	6.96	M_2			1585	1256	1177	2160	1754			
			c			3.4	4.2	4.3	2.5	2.8			
			$n_{2 \text{ Eck}}$			9	18	21	12	24			
			$n_{2 \text{ th}}$			9	18	21	11	24			
170.074	8408	6.96	M_2								1423		2540
			c								5.6		3.2
			$n_{2 \text{ Eck}}$								9		9
			$n_{2 \text{ th}}$								9		9
202.074	4498	3.69	M_2	1026	797	1904	1514	1419	2587	2104			
			c	4.2	4.9	2.3	2.9	2.9	1.7	1.9			
			$n_{2 \text{ Eck}}$	10	20	7	15	17	10	20			
			$n_{2 \text{ th}}$	10	20	7	15	17	10	20			
202.074	7010	3.69	M_2								1722	1395	3049
			c								4	4.6	2.3
			$n_{2 \text{ Eck}}$								7	18	7
			$n_{2 \text{ th}}$								7	18	7
224.636	6236	4.74	M_2	1128		2104	1670	1565	2863	2327			
			c	5.3		2.9	3.6	3.7	2.2	2.4			
			$n_{2 \text{ Eck}}$	9		7	13	16	9	18			
			$n_{2 \text{ th}}$	9		7	13	16	9	18			
224.636	8739	4.74	M_2								1904	1541	3379
			c								4.4	5.1	2.5
			$n_{2 \text{ Eck}}$								7	16	7
			$n_{2 \text{ th}}$								7	16	7
253.111	7027	4.7	M_2	1271		2371	1882	1763	3226	2622			
			c	5.3		2.9	3.6	3.7	2.2	2.4			
			$n_{2 \text{ Eck}}$	8		6	12	14	8	16			
			$n_{2 \text{ th}}$	8		6	12	14	8	16			
253.111	9846	4.7	M_2								2146	1736	3808
			c								4.4	5.1	2.5
			$n_{2 \text{ Eck}}$								6	14	6
			$n_{2 \text{ th}}$								6	14	6

$M \dots$ [Nm]
 $n \dots$ [min^{-1}]
 $J \dots$ [kgcm^2]

$P \dots$ [kW]
 $I \dots$ [A]
 $i \dots$ [-]
 $c \dots$ [-]

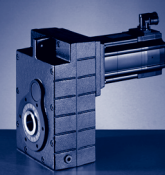

$M_{2GN} \leq 11496 \text{ Nm}$

14HC32	14LC15	14LC32	14PC14	14PC32	19FC14	19FC30	19JC14	19JC30	19PC14	19PC30	GFL14-3S			
...S00	...S00	...S00	...S00	...S00	...S00	...S00	...S00	...S00	...S00	...S00	M_1	J_G	M_{2GN}	i
14	23	17.2	30	21	27	21	40	29	51	32	n_1			
3225	1500	3225	1350	3225	1425	3000	1425	3000	1350	3000	I_{M230}			
11.9	9.7	15	10.8	15.6	8.6	14	12.3	18.5	14.3	19	I_{M400}			
4.7	3.6	5.8	4.2	7.1	4	6.6	6	9.1	7.2	10	P_N			
14.32	23.44	23.44	34.74	34.82	65.12	65.04	105.04	105.12	160.12	160.04	J_M			
											M_2 c			
											$n_{2 \text{ Eck}}$	8.14	4166	128.593
											$n_{2 \text{ th}}$			
1672	2788	2069	3657	2541							M_2 c			
3.7	2.3	3	1.8	2.5							$n_{2 \text{ Eck}}$	8.14	6506	128.593
25	12	25	11	25							$n_{2 \text{ th}}$			
25	12	25	11	25							$n_{2 \text{ th}}$			
1775	2963	2198	3889	2701	3492	2699	5211	3757	6665	4153	M_2 c			
3.9	2.5	3.2	1.9	2.6	2.1	2.7	1.4	1.9	1.1	1.8	$n_{2 \text{ Eck}}$	16.78	7359	136.889
24	11	24	10	24	10	22	10	22	10	22	$n_{2 \text{ th}}$			
23	11	22	10	21	10	16	10	16	10	16	$n_{2 \text{ th}}$			
											M_2 c			
											$n_{2 \text{ Eck}}$	5.92	4335	156.148
											$n_{2 \text{ th}}$			
2042	3397	2525	4453	3097							M_2 c			
3.2	2	2.6	1.5	2.1							$n_{2 \text{ Eck}}$	5.92	6760	156.148
21	10	21	9	21							$n_{2 \text{ th}}$			
21	10	21	9	21							$n_{2 \text{ th}}$			
											M_2 c			
											$n_{2 \text{ Eck}}$	6.96	5510	170.074
											$n_{2 \text{ th}}$			
2213	3689	2739	4839	3363							M_2 c			
3.6	2.3	2.9	1.7	2.4							$n_{2 \text{ Eck}}$	6.96	8408	170.074
19	9	19	8	19							$n_{2 \text{ th}}$			
19	9	19	8	19							$n_{2 \text{ th}}$			
											M_2 c			
											$n_{2 \text{ Eck}}$	3.69	4498	202.074
											$n_{2 \text{ th}}$			
2660	4415	3285	5781	4026							M_2 c			
2.5	1.6	2.1	1.2	1.7							$n_{2 \text{ Eck}}$	3.69	7010	202.074
16	7	16	7	16							$n_{2 \text{ th}}$			
16	7	16	7	16							$n_{2 \text{ th}}$			
											M_2 c			
											$n_{2 \text{ Eck}}$	4.74	6236	224.636
											$n_{2 \text{ th}}$			
2948	4898	3642	6416	4466							M_2 c			
2.8	1.8	2.3	1.4	1.9							$n_{2 \text{ Eck}}$	4.74	8739	224.636
14	7	14	6	14							$n_{2 \text{ th}}$			
14	7	14	6	14							$n_{2 \text{ th}}$			
											M_2 c			
											$n_{2 \text{ Eck}}$	4.7	7027	253.111
											$n_{2 \text{ th}}$			
3321	5519	4103	7230	5032							M_2 c			
2.8	1.8	2.3	1.4	1.9							$n_{2 \text{ Eck}}$	4.7	9846	253.111
13	6	13	5	13							$n_{2 \text{ th}}$			
13	6	13	5	13							$n_{2 \text{ th}}$			

$M \dots$ [Nm]
 $n \dots$ [min^{-1}]
 $J \dots$ [kgcm^2]

$P \dots$ [kW]
 $I \dots$ [A]
 i [-]
 c [-]

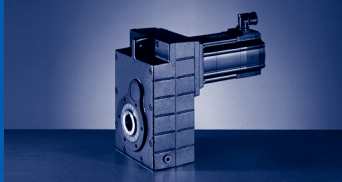

GFL [Nm]

GFL□□-□S (MCS)

$M_{2GN} \leq 11496 \text{ Nm}$

GFL14-3S				12DC20	12DC41	12HC15	12HC30	12HC35	12LC20	12LC41	14DC15	14DC36	14HC15
				...500	...500	...500	...500	...500	...500	...500	...500	...500	...500
i	M_{2GN}	J_G	M_1	5.5	4.3	10	8	7.5	13.5	11	9.2	7.5	16
			n_1	1950	4050	1500	3000	3525	1950	4050	1500	3600	1500
			I_{M230}	5.2	8.8	7.6	10.5		11.8				
			I_{M400}	2.6	4.5	3.8		5.7	5.9	10.2	4.5	7.5	6.6
			P_N	1.1	1.8	1.6	2.5	2.8	2.8	4.7	1.45	2.8	2.5
			J_M	4.12	4.12	7.42	7.42	7.42	10.72	10.72	8.22	8.22	14.32
273.778	8870	5.76	M_2			2551	2022	1895	3476	2824			
			c			3.4	4.2	4.3	2.5	2.8			
			$n_{2 \text{ Eck}}$			6	11	13	7	15			
			$n_{2 \text{ th}}$			5	11	13	7	15			
273.778	9753	5.76	M_2								2330	1887	4128
			c								4.1	4.7	2.3
			$n_{2 \text{ Eck}}$								6	13	6
			$n_{2 \text{ th}}$								5	13	5
332.444	9229	4.3	M_2	1669		3114	2472	2316	4237	3444			
			c	5.3		2.9	3.6	3.7	2.2	2.4			
			$n_{2 \text{ Eck}}$	6		5	9	11	6	12			
			$n_{2 \text{ th}}$	6		5	9	11	6	12			
332.444	10550	4.3	M_2								2843	2304	5026
			c								3.6	4.2	2.1
			$n_{2 \text{ Eck}}$								5	11	5
			$n_{2 \text{ th}}$								5	11	5
352.811	6551	2.16	M_2	1805	1403	3338	2657	2490	4531	3686			
			c	3.5	4.1	1.9	2.4	2.5	1.4	1.6			
			$n_{2 \text{ Eck}}$	6	12	4	9	10	6	12			
			$n_{2 \text{ th}}$	6	11	4	9	10	6	11			
352.811	10203	2.16	M_2								3028	2455	5344
			c								3.3	3.8	1.9
			$n_{2 \text{ Eck}}$								4	10	4
			$n_{2 \text{ th}}$								4	10	4
397.533	7382	2.15	M_2	2034	1581	3762	2994	2806	5105	4153			
			c	3.5	4.1	1.9	2.4	2.5	1.4	1.6			
			$n_{2 \text{ Eck}}$	5	10	4	8	9	5	10			
			$n_{2 \text{ th}}$	5	10	4	8	9	5	10			
397.533	11496	2.15	M_2								3411	2766	6022
			c								3.3	3.8	1.9
			$n_{2 \text{ Eck}}$								4	9	4
			$n_{2 \text{ th}}$								4	9	4
430.222	9576	2.73	M_2	2185	1696	4054	3223	3021	5508	4479			
			c	4.2	4.9	2.3	2.9	2.9	1.7	1.9			
			$n_{2 \text{ Eck}}$	5	9	4	7	8	5	9			
			$n_{2 \text{ th}}$	5	9	3	7	8	5	9			
430.222	10560	2.73	M_2								3712	3012	6537
			c								2.8	3.2	1.6
			$n_{2 \text{ Eck}}$								4	8	4
			$n_{2 \text{ th}}$								3	8	3
522.133	9695	1.98	M_2	2672	2076	4941	3932	3685	6705	5455			
			c	3.5	4.1	1.9	2.4	2.5	1.4	1.6			
			$n_{2 \text{ Eck}}$	4	8	3	6	7	4	8			
			$n_{2 \text{ th}}$	4	8	3	6	7	4	8			
522.133	10560	1.98	M_2								4528	3678	7957
			c								2.3	2.7	1.3
			$n_{2 \text{ Eck}}$								3	7	3
			$n_{2 \text{ th}}$								3	7	3
562.391	9036	1.91	M_2	2892	2250	5336	4250	3984	7237	5888	4902	3984	8595
			c	3.1	3.5	1.7	2.1	2.1	1.3	1.4	1.8	2.1	1.1
			$n_{2 \text{ Eck}}$	4	7	3	5	6	4	7	3	6	3
			$n_{2 \text{ th}}$	3	7	3	5	6	3	7	3	6	3

$M \dots$ [Nm]
 $n \dots$ [min^{-1}]
 $J \dots$ [kgcm^2]

$P \dots$ [kW]
 $I \dots$ [A]
 $i \dots$ [-]
 $c \dots$ [-]

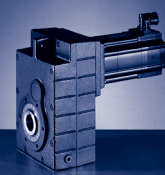

$M_{2GN} \leq 11496 \text{ Nm}$

14HC32	14LC15	14LC32	14PC14	14PC32	19FC14	19FC30	19JC14	19JC30	19PC14	19PC30	GFL14-3S			
...S00	...S00	...S00	...S00	...S00	...S00	...S00	...S00	...S00	...S00	...S00	M_1	J_G	M_{2GN}	i
14	23	17.2	30	21	27	21	40	29	51	32	n_1			
3225	1500	3225	1350	3225	1425	3000	1425	3000	1350	3000	I_{M230}			
11.9	9.7	15	10.8	15.6	8.6	14	12.3	18.5	14.3	19	I_{M400}			
4.7	3.6	5.8	4.2	7.1	4	6.6	6	9.1	7.2	10	P_N			
14.32	23.44	23.44	34.74	34.82	65.12	65.04	105.04	105.12	160.12	160.04	J_M			
											M_2			
											c	5.76	8870	273.778
											n_2 Eck			
											n_2 th			
3602	5979	4448	7829	5452							M_2			
2.6	1.6	2.1	1.2	1.7							c	5.76	9753	273.778
12	6	12	5	12							n_2 Eck			
12	5	12	5	12							n_2 th			
											M_2			
											c	4.3	9229	332.444
											n_2 Eck			
											n_2 th			
4387	7273	5414	9521	6634							M_2			
2.3	1.4	1.9	1.1	1.5							c	4.3	10550	332.444
10	5	10	4	10							n_2 Eck			
10	5	10	4	10							n_2 th			
											M_2			
											c	2.16	6551	352.811
											n_2 Eck			
											n_2 th			
4666	7729	5756	10114	7050							M_2			
2.1	1.3	1.7	1	1.4							c	2.16	10203	352.811
9	4	9	4	9							n_2 Eck			
9	4	9	4	9							n_2 th			
											M_2			
											c	2.15	7382	397.533
											n_2 Eck			
											n_2 th			
5257	8709	6485	11396	7944							M_2			
2.1	1.3	1.7	1	1.4							c	2.15	11496	397.533
8	4	8	3	8							n_2 Eck			
8	4	8	3	8							n_2 th			
											M_2			
											c	2.73	9576	430.222
											n_2 Eck			
											n_2 th			
5708	9445	7038		8617							M_2			
1.8	1.1	1.5		1.2							c	2.73	10560	430.222
8	4	8		8							n_2 Eck			
8	3	8		8							n_2 th			
											M_2			
											c	1.98	9695	522.133
											n_2 Eck			
											n_2 th			
6951		8565									M_2			
1.5		1.2									c	1.98	10560	522.133
6		6									n_2 Eck			
6		6									n_2 th			
7511											M_2			
1.2											c	1.91	9036	562.391
6											n_2 Eck			
6											n_2 th			

$M \dots$ [Nm]
 $n \dots$ [min^{-1}]
 $J \dots$ [kgcm^2]

$P \dots$ [kW]
 $I \dots$ [A]
 i [-]
 c [-]

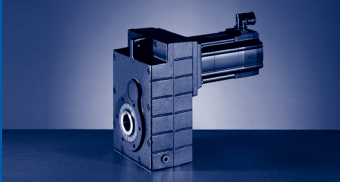

GFL [Nm]

GFL□□-□S (MCS)

$M_{2GN} \leq 11496 \text{ Nm}$

GFL14-3S				12DC20	12DC41	12HC15	12HC30	12HC35	12LC20	12LC41	14DC15	14DC36	14HC15	
				...500	...500	...500	...500	...500	...500	...500	...500	...500	...500	
i	M_{2GN}	J_G	M_1	5.5	4.3	10	8	7.5	13.5	11	9.2	7.5	16	
			n_1	1950	4050	1500	3000	3525	1950	4050	1500	3600	1500	
			I_{M230}	5.2	8.8	7.6	10.5		11.8					
			I_{M400}	2.6	4.5	3.8		5.7	5.9	10.2	4.5	7.5	6.6	
			P_N	1.1	1.8	1.6	2.5	2.8	2.8	4.7	1.45	2.8	2.5	
			J_M	4.12	4.12	7.42	7.42	7.42	10.72	10.72	8.22	8.22	14.32	
633.68	9811	1.9	M_2	3263	2538	6017	4793	4492	8158	6638	5527	4493	9688	
			c	3	3.4	1.6	2	2.1	1.2	1.3	1.8	2	1	
			$n_{2 \text{ Eck}}$	3	6	2	5	6	3	6	2	6	2	2
			$n_{2 \text{ th}}$	3	6	2	5	6	3	6	2	6	2	2
710.888	9036	1.26	M_2	3681	2866	6770	5397	5059		7466				
			c	2.4	2.8	1.3	1.7	1.7		1.1				
			$n_{2 \text{ Eck}}$	3	6	2	4	5		6				
			$n_{2 \text{ th}}$	3	6	2	4	5		6				
801	9811	1.25	M_2	4152	3233	7632	6085	5704		8416				
			c	2.3	2.7	1.3	1.6	1.6		1.1				
			$n_{2 \text{ Eck}}$	2	5	2	4	4		5				
			$n_{2 \text{ th}}$	2	5	2	4	4		5				

$M \dots$ [Nm]
 $n \dots$ [min^{-1}]
 $J \dots$ [kgcm^2]

$P \dots$ [kW]
 $I \dots$ [A]
 i [-]
 c [-]

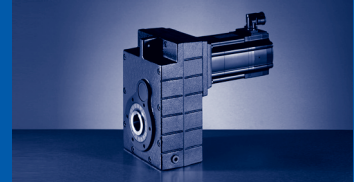

$M_{2GN} \leq 11496 \text{ Nm}$

14HC32	14LC15	14LC32	14PC14	14PC32	19FC14	19FC30	19JC14	19JC30	19PC14	19PC30	GFL14-3S			
...S00	...S00	...S00	...S00	...S00	...S00	...S00	...S00	...S00	...S00	...S00	M_1	J_G	M_{2GN}	i
14	23	17.2	30	21	27	21	40	29	51	32	n_1			
3225	1500	3225	1350	3225	1425	3000	1425	3000	1350	3000	I_{M230}			
											I_{M400}			
11.9	9.7	15	10.8	15.6	8.6	14	12.3	18.5	14.3	19	P_N			
4.7	3.6	5.8	4.2	7.1	4	6.6	6	9.1	7.2	10	J_M			
14.32	23.44	23.44	34.74	34.82	65.12	65.04	105.04	105.12	160.12	160.04	M_2			
8467											c			
1.1											$n_{2 \text{ Eck}}$	1.9	9811	633.68
5											$n_{2 \text{ th}}$			
5											M_2			
											c			
											$n_{2 \text{ Eck}}$	1.26	9036	710.888
											$n_{2 \text{ th}}$			
											M_2			
											c			
											$n_{2 \text{ Eck}}$	1.25	9811	801
											$n_{2 \text{ th}}$			

M ... [Nm]
n ... [min⁻¹]
J ... [kgcm²]

P ... [kW]
I ... [A]
i [-]
c [-]

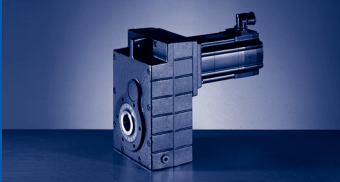

GFL [Nm]

GFL□□-□A (MCA)

$M_{2GN} \leq 187 \text{ Nm}$

GFL04-2A				10IC40	13IC34	13IC41
				...500	...F10	...500
i	M_{2GN}	J_G	M_1			
			n_1	2	6.3	4
			I_{M400}	3950	3410	4050
			P_N	2.4	6	4.4
			J_M	0.8	2.2	1.7
			M_2	2.44	8.34	8.34
3.659	109	1.51	c		22	14
			n_2 Eck		3.7	5.5
			n_2 th		932	1107
					932	1003
5.018	111	0.86	M_2		30	19
			c		2.8	4.1
			n_2 Eck		680	807
			n_2 th		680	769
5.833	153	0.93	M_2		35	22
			c		3.3	4.9
			n_2 Eck		585	694
			n_2 th		572	616
6.422	113	0.56	M_2		39	24
			c		2.2	3.2
			n_2 Eck		531	631
			n_2 th		531	631
7.025	113	0.47	M_2	13	42	27
			c	6	2	3
			n_2 Eck	562	485	577
			n_2 th	562	485	576
8.379	179	0.67	M_2		50	32
			c		2.7	3.9
			n_2 Eck		407	483
			n_2 th		382	413
9.333	165	0.61	M_2		56	35
			c		2.2	3.3
			n_2 Eck		365	434
			n_2 th		330	358
10.238	159	0.37	M_2	19	62	39
			c	5.8	1.9	2.9
			n_2 Eck	386	333	396
			n_2 th	386	333	396
11.491	181	0.41	M_2	21	70	44
			c	5.9	2	2.9
			n_2 Eck	344	297	353
			n_2 th	344	294	317
12.8	166	0.38	M_2	24	78	49
			c	4.8	1.6	2.4
			n_2 Eck	309	266	316
			n_2 th	309	240	274
14.706	182	0.28	M_2	27	89	56
			c	4.6	1.5	2.3
			n_2 Eck	269	232	275
			n_2 th	269	232	275
16.087	182	0.25	M_2	30	98	62
			c	4.2	1.4	2.1
			n_2 Eck	246	212	252
			n_2 th	246	212	252
17.92	167	0.23	M_2	34	109	69
			c	3.5	1.2	1.7
			n_2 Eck	220	190	226
			n_2 th	220	181	217

$M \dots$ [Nm]
 $n \dots$ [min^{-1}]
 $J \dots$ [kgcm^2]

$P \dots$ [kW]
 $I \dots$ [A]
 i [-]
 c [-]

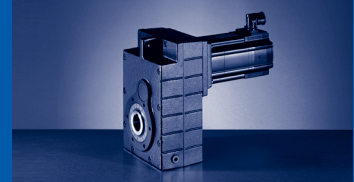

$M_{2GN} \leq 187 \text{ Nm}$

GFL04-2A				10IC40	13IC34	13IC41
				...S00	...F10	...S00
i	M_{2GN}	J_G	M_1			
			n_1	2	6.3	4
			I_{M400}	3950	3410	4050
			P_N	2.4	6	4.4
			J_M	0.8	2.2	1.7
			M_2	2.44	8.34	8.34
			c	39	125	79
20.519	183	0.17	$n_2 \text{ Eck}$	3.3	1.1	1.7
			$n_2 \text{ th}$	193	166	197
				193	166	197
			M_2	44		88
			c	2.7		1.4
22.857	167	0.16	$n_2 \text{ Eck}$	173		177
			$n_2 \text{ th}$	173		174
			M_2	48	154	97
			c	3.1	1	1.5
25.136	183	0.13	$n_2 \text{ Eck}$	157	136	161
			$n_2 \text{ th}$	157	136	161
			M_2	53		108
			c	2.5		1.3
28	168	0.12	$n_2 \text{ Eck}$	141		145
			$n_2 \text{ th}$	141		145
			M_2	60		
			c	2.5		
31.6	185	0.09	$n_2 \text{ Eck}$	125		
			$n_2 \text{ th}$	125		
			M_2	68		
			c	2.1		
35.2	170	0.08	$n_2 \text{ Eck}$	112		
			$n_2 \text{ th}$	112		
			M_2	78		
			c	2		
40.697	187	0.06	$n_2 \text{ Eck}$	97		
			$n_2 \text{ th}$	97		
			M_2	87		
			c	1.6		
45.333	172	0.06	$n_2 \text{ Eck}$	87		
			$n_2 \text{ th}$	87		

M ... [Nm]
n ... [min^{-1}]
J ... [kgcm^2]

P ... [kW]
I ... [A]
i [-]
c [-]

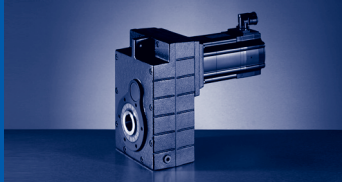

GFL [Nm]

GFL□□-□A (MCA)

$M_{2GN} \leq 345 \text{ Nm}$

GFL05-2A				10IC40	13IC34	13IC41	14LC16	14LC20	14LC35	14LC41
				...S00	...F10	...S00	...F10	...S00	...F10	...S00
i	M_{2GN}	J_G	M_1	2	6.3	4	12	6.7	10.8	5.4
			n_1	3950	3410	4050	1635	2000	3455	4100
			I_{M400}	2.4	6	4.4	4.8	3.3	9.1	5.8
			P_N	0.8	2.2	1.7	2.1	1.4	3.9	2.3
			J_M	2.44	8.34	8.34	19.32	19.24	19.24	19.24
3.333	138	1.68	M_2		20					
			c		5.1					
			$n_{2 \text{ Eck}}$		1023					
			$n_{2 \text{ th}}$		910					
3.333	166	1.68	M_2				38		34	
			c				4.2		3.6	
			$n_{2 \text{ Eck}}$				491		1037	
			$n_{2 \text{ th}}$				491		849	
4.571	170	2.13	M_2		27		52	28	47	23
			c		4.6		3.1	5.2	2.7	5.1
			$n_{2 \text{ Eck}}$		746		358	438	756	897
			$n_{2 \text{ th}}$		746		358	438	686	775
5.133	212	2.37	M_2		30					
			c		5.1					
			$n_{2 \text{ Eck}}$		664					
			$n_{2 \text{ th}}$		591					
5.133	223	2.37	M_2				58		53	26
			c				3.6		3.1	5.9
			$n_{2 \text{ Eck}}$				319		673	799
			$n_{2 \text{ th}}$				319		536	607
5.667	233	2.33	M_2		33		64	35	58	28
			c		5.1		3.4	5.7	3	5.6
			$n_{2 \text{ Eck}}$		602		289	353	610	724
			$n_{2 \text{ th}}$		535		289	353	480	544
6.4	173	0.82	M_2		38	24	74	40	66	33
			c		3.4	5	2.3	3.8	2	3.7
			$n_{2 \text{ Eck}}$		533	633	256	313	540	641
			$n_{2 \text{ th}}$		533	621	255	313	527	561
7.04	248	1.47	M_2		42		80	44	73	35
			c		4.4		2.9	4.9	2.6	4.8
			$n_{2 \text{ Eck}}$		484		232	284	491	582
			$n_{2 \text{ th}}$		484		232	284	440	498
7.771	258	1.45	M_2		46		89	49	80	39
			c		4.1		2.8	4.7	2.4	4.5
			$n_{2 \text{ Eck}}$		439		210	257	445	528
			$n_{2 \text{ th}}$		439		210	257	394	447
9.01	266	0.95	M_2		54	33	103	57	93	46
			c		3.7	5.5	2.5	4.1	2.1	4
			$n_{2 \text{ Eck}}$		379	450	182	222	384	455
			$n_{2 \text{ th}}$		378	433	181	222	366	399
9.946	275	0.89	M_2		59	37	114	63	103	51
			c		3.4	5.1	2.3	3.9	2	3.8
			$n_{2 \text{ Eck}}$		343	407	164	201	347	412
			$n_{2 \text{ th}}$		343	388	164	201	329	361
11.36	278	1.08	M_2		68	42	131	72	118	58
			c		3.1	4.5	2.1	3.4	1.8	3.4
			$n_{2 \text{ Eck}}$		300	357	144	176	304	361
			$n_{2 \text{ th}}$		283	305	144	176	243	288
12.8	285	1.01	M_2		77	48	148	81	133	66
			c		2.8	4.1	1.9	3.1	1.6	3
			$n_{2 \text{ Eck}}$		266	316	128	156	270	320
			$n_{2 \text{ th}}$		246	266	128	156	204	251

$M \dots$ [Nm]
 $n \dots$ [min^{-1}]
 $J \dots$ [kgcm^2]

$P \dots$ [kW]
 $I \dots$ [A]
 i [-]
 c [-]

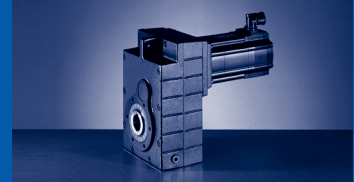

$M_{2GN} \leq 345 \text{ Nm}$

GFL05-2A				10IC40	13IC34	13IC41	14LC16	14LC20	14LC35	14LC41
				...S00	...F10	...S00	...F10	...S00	...F10	...S00
i	M_{2GN}	J_G	M_1	2	6.3	4	12	6.7	10.8	5.4
			n_1	3950	3410	4050	1635	2000	3455	4100
			I_{M400}	2.4	6	4.4	4.8	3.3	9.1	5.8
			P_N	0.8	2.2	1.7	2.1	1.4	3.9	2.3
			J_M	2.44	8.34	8.34	19.32	19.24	19.24	19.24
14.538	301	0.75	M_2		87	55	168	93	152	75
			c		2.6	3.8	1.7	2.9	1.5	2.8
			$n_{2 \text{ Eck}}$		235	279	113	138	238	282
			$n_{2 \text{ th}}$		235	253	112	138	195	239
15.904	310	0.6	M_2		96	60	184	102	166	82
			c		2.4	3.6	1.6	2.7	1.4	2.7
			$n_{2 \text{ Eck}}$		214	255	103	126	217	258
			$n_{2 \text{ th}}$		214	237	103	126	181	225
17.92	312	0.61	M_2		108	68	208	115	187	93
			c		2.2	3.2	1.5	2.4	1.3	2.4
			$n_{2 \text{ Eck}}$		190	226	91	112	193	229
			$n_{2 \text{ th}}$		190	206	91	112	154	195
20.286	333	0.43	M_2		123	77	235	130	212	105
			c		2	3	1.4	2.3	1.2	2.2
			$n_{2 \text{ Eck}}$		168	200	81	99	170	202
			$n_{2 \text{ th}}$		168	200	81	99	155	177
22.857	313	0.43	M_2	42	139	87	266	147		119
			c	5.1	1.7	2.5	1.1	1.9		1.9
			$n_{2 \text{ Eck}}$	173	149	177	72	88		179
			$n_{2 \text{ th}}$	173	149	177	72	88		157
24.85	344	0.35	M_2	46	150	95	289	160	260	129
			c	5.9	2	2.9	1.2	2.1	1.1	2.2
			$n_{2 \text{ Eck}}$	159	137	163	66	81	139	165
			$n_{2 \text{ th}}$	159	137	163	66	80	139	144
28	314	0.33	M_2	52	170	107		181		146
			c	4.8	1.6	2.4		1.7		1.7
			$n_{2 \text{ Eck}}$	141	122	145		71		146
			$n_{2 \text{ th}}$	141	122	145		71		128
32.344	345	0.2	M_2	60	197	124				
			c	4.5	1.5	2.2				
			$n_{2 \text{ Eck}}$	122	105	125				
			$n_{2 \text{ th}}$	122	105	125				
36.444	316	0.2	M_2	69	222	140				
			c	3.7	1.2	1.8				
			$n_{2 \text{ Eck}}$	108	94	111				
			$n_{2 \text{ th}}$	108	94	111				
40.233	345	0.15	M_2	76	245	155				
			c	3.6	1.2	1.8				
			$n_{2 \text{ Eck}}$	98	85	101				
			$n_{2 \text{ th}}$	98	85	101				
45.333	319	0.14	M_2	86		175				
			c	3		1.5				
			$n_{2 \text{ Eck}}$	87		89				
			$n_{2 \text{ th}}$	87		89				
52.067	309	0.09	M_2	99						
			c	2.5						
			$n_{2 \text{ Eck}}$	76						
			$n_{2 \text{ th}}$	76						
58.667	322	0.09	M_2	112						
			c	2.3						
			$n_{2 \text{ Eck}}$	67						
			$n_{2 \text{ th}}$	67						

M ... [Nm]
n ... [min⁻¹]
J ... [kgcm²]

P ... [kW]
I ... [A]
i [-]
c [-]

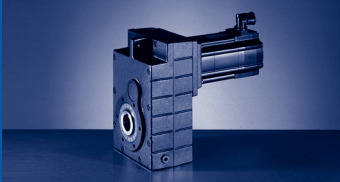

GFL [Nm]

GFL□□-□A (MCA)

$M_{2GN} \leq 345 \text{ Nm}$

GFL05-2A				10IC40	13IC34	13IC41	14LC16	14LC20	14LC35	14LC41
				...S00	...F10	...S00	...F10	...S00	...F10	...S00
i	M_{2GN}	J_G	M_1							
			n_1	3950	3410	4050	1635	2000	3455	4100
			I_{M400}	2.4	6	4.4	4.8	3.3	9.1	5.8
			P_N	0.8	2.2	1.7	2.1	1.4	3.9	2.3
			J_M	2.44	8.34	8.34	19.32	19.24	19.24	19.24
63.19	282	0.07	M_2	121						
			c	1.9						
			$n_{2 \text{ Eck}}$	63						
			$n_{2 \text{ th}}$	63						
71.2	305	0.06	M_2	137						
			c	2						
			$n_{2 \text{ Eck}}$	56						
			$n_{2 \text{ th}}$	55						

M ... [Nm]
 n ... [min^{-1}]
 J ... [kgcm^2]

P ... [kW]
 I ... [A]
 i [-]
 c [-]

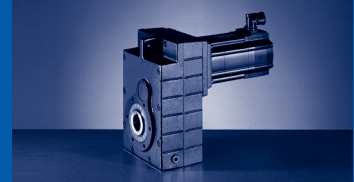

$M_{2GN} \leq 345 \text{ Nm}$

GFL05-3A				10IC40
				...500
i	M_{2GN}	J_G	M_1	
			n_1	2
			I_{M400}	3950
			P_N	2.4
			J_M	0.8
			M_2	2.44
			c	117
61.653	207	0.2	$n_{2 \text{ Eck}}$	1.5
			$n_{2 \text{ th}}$	64
			M_2	64
			c	150
78.639	225	0.14	$n_{2 \text{ Eck}}$	1.4
			$n_{2 \text{ th}}$	50
			M_2	50
			c	171
90.123	303	0.2	$n_{2 \text{ Eck}}$	1.6
			$n_{2 \text{ th}}$	44
			M_2	44
			c	193
101.547	328	0.2	$n_{2 \text{ Eck}}$	1.5
			$n_{2 \text{ th}}$	39
			M_2	39
			c	219
114.952	329	0.14	$n_{2 \text{ Eck}}$	1.4
			$n_{2 \text{ th}}$	34
			M_2	34
			c	247
129.524	328	0.14	$n_{2 \text{ Eck}}$	1.2
			$n_{2 \text{ th}}$	31
			M_2	31
			c	269
140.817	345	0.11	$n_{2 \text{ Eck}}$	1.2
			$n_{2 \text{ th}}$	28
			M_2	28
			c	28

M ... [Nm]
n ... [min⁻¹]
J ... [kgcm²]

P ... [kW]
I ... [A]
i [-]
c [-]

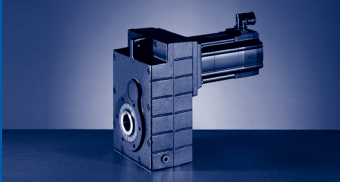

GFL [Nm]

GFL□□-□A (MCA)

$M_{2GN} \leq 660 \text{ Nm}$

GFL06-2A				10IC40	13IC34	13IC41	14LC16	14LC20	14LC35	14LC41	17NC17	17NC23	17NC35	17NC41
				...S00	...F10	...S00	...F10	...S00	...F10	...S00	...F10	...S00	...F10	...S00
i	M_{2GN}	J_G	M_1	2	6.3	4	12	6.7	10.8	5.4	21.5	10.8	19	9.5
			n_1	3950	3410	4050	1635	2000	3455	4100	1680	2300	3480	4110
			I_{M400}	2.4	6	4.4	4.8	3.3	9.1	5.8	8.5	5.5	15.8	10.2
			P_N	0.8	2.2	1.7	2.1	1.4	3.9	2.3	3.8	2.6	6.9	4.1
			J_M	2.44	8.34	8.34	19.32	19.24	19.24	19.24	36.04	36.04	36.04	36.04
3.675	266	7.76	M_2						37					
			c						5.2					
			n_2 Eck						940					
			n_2 th						702					
3.675	311	7.76	M_2								74		66	
			c								3.9		3.5	
			n_2 Eck								457		947	
			n_2 th								457		645	
5.211	377	6.64	M_2						52					
			c						5.2					
			n_2 Eck						663					
			n_2 th						495					
5.211	424	6.64	M_2								106		94	
			c								3.8		3.3	
			n_2 Eck								322		668	
			n_2 th								322		451	
5.75	416	6.04	M_2						58					
			c						5.2					
			n_2 Eck						601					
			n_2 th						448					
5.75	442	6.04	M_2								117		104	50
			c								3.6		3.2	6
			n_2 Eck								292		605	715
			n_2 th								292		403	460
6.45	263	3.65	M_2		38									
			c		5.1									
			n_2 Eck		529									
			n_2 th		529									
6.45	352	3.65	M_2				72		66		132	65	117	57
			c				4.6		3.9		2.5	4.5	2.2	4.2
			n_2 Eck				254		536		261	357	540	637
			n_2 th				253		507		260	357	451	482
7.147	433	4.04	M_2				80		72		146	72	130	63
			c				5.1		4.4		2.8	5	2.5	4.7
			n_2 Eck				229		483		235	322	487	575
			n_2 th				229		404		235	322	359	409
8.4	604	4.26	M_2				93		84		171	84	152	74
			c				6		5.2		3.3	6	3	5.6
			n_2 Eck				195		411		200	274	414	489
			n_2 th				195		307		200	274	272	311
9.463	581	3.88	M_2				105		96		194	95	172	84
			c				5.1		4.4		2.8	5.1	2.5	4.8
			n_2 Eck				173		365		178	243	368	434
			n_2 th				173		264		178	243	233	267
10.092	412	2.52	M_2		59									
			c		5.1									
			n_2 Eck		338									
			n_2 th		338									
10.092	459	2.52	M_2				114		103		208	103	184	91
			c				3.8		3.3		2.1	3.8	1.9	3.5
			n_2 Eck				162		342		167	228	345	407
			n_2 th				162		313		166	228	271	308

$M \dots$ [Nm]
 $n \dots$ [min^{-1}]
 $J \dots$ [kgcm^2]

$P \dots$ [kW]
 $I \dots$ [A]
 i [-]
 c [-]

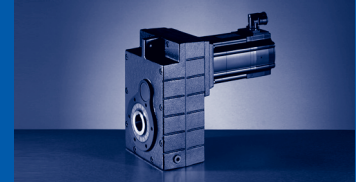

$M_{2GN} \leq 660 \text{ Nm}$

GFL06-2A				10IC40	13IC34	13IC41	14LC16	14LC20	14LC35	14LC41	17NC17	17NC23	17NC35	17NC41	
				...S00	...F10	...S00	...F10	...S00	...F10	...S00	...F10	...S00	...F10	...S00	
i	M_{2GN}	J_G	M_1	2	6.3	4	12	6.7	10.8	5.4	21.5	10.8	19	9.5	
			n_1	3950	3410	4050	1635	2000	3455	4100	1680	2300	3480	4110	
			I_{M400}	2.4	6	4.4	4.8	3.3	9.1	5.8	8.5	5.5	15.8	10.2	
			P_N	0.8	2.2	1.7	2.1	1.4	3.9	2.3	3.8	2.6	6.9	4.1	
			J_M	2.44	8.34	8.34	19.32	19.24	19.24	19.24	36.04	36.04	36.04	36.04	
11.52	632	1.73	M_2				129		117		237	116	210	103	
			c			4.6		4		2.5		4.5		2.3	4.3
			$n_{2 \text{ Eck}}$			142		300		146		200		302	357
			$n_{2 \text{ th}}$			142		246		146		200		217	249
12.978	592	2.61	M_2				147		133		268	132	237	116	
			c			3.8		3.3		2.1		3.8		1.9	3.5
			$n_{2 \text{ Eck}}$			126		266		130		177		268	317
			$n_{2 \text{ th}}$			126		210		129		177		182	213
14.743	602	1.95	M_2		86										
			c		5.1										
			$n_{2 \text{ Eck}}$		231										
			$n_{2 \text{ th}}$		231										
14.743	641	1.95	M_2				167		151	73	304	150	270	133	
			c			3.6		3.1	5.9	2	3.6	1.8	3.4		
			$n_{2 \text{ Eck}}$			111		234	278	114	156	236	279		
			$n_{2 \text{ th}}$			111		212	240	114	156	181	211		
16.128	643	1.68	M_2		95		183	100	166	81	334	165	295	145	
			c		5		3.3	5.6	2.9	5.4	1.8	3.3	1.6	3.1	
			$n_{2 \text{ Eck}}$		211		101	124	214	254	104	143	216	255	
			$n_{2 \text{ th}}$		211		101	124	197	223	104	143	164	193	
18.169	600	1.57	M_2		108		208	114	188	92	377	187	334	165	
			c		4.1		2.8	4.6	2.4	4.5	1.5	2.7	1.4	2.6	
			$n_{2 \text{ Eck}}$		188		90	110	190	226	93	127	192	226	
			$n_{2 \text{ th}}$		188		90	110	168	191	92	127	132	171	
20.571	645	1.19	M_2		122	76	236	129	213	104	427	212	378	187	
			c		3.9	5.8	2.6	4.4	2.3	4.3	1.5	2.6	1.3	2.4	
			$n_{2 \text{ Eck}}$		166	197	80	97	168	199	82	112	169	200	
			$n_{2 \text{ th}}$		166	193	79	97	164	175	82	112	130	151	
23.175	604	1.13	M_2		138	86	267	147	241	118	482	240	427	211	
			c		3.2	4.8	2.2	3.6	1.9	3.6	1.2	2.2	1.1	2	
			$n_{2 \text{ Eck}}$		147	175	71	86	149	177	73	99	150	177	
			$n_{2 \text{ th}}$		147	166	71	86	138	155	72	99	107	134	
25.2	651	0.9	M_2		150	93	290	159	261	128	524	260	464	229	
			c		3.7	5.4	2.2	4	2.1	4	1.2	2.4	1.2	2.3	
			$n_{2 \text{ Eck}}$		135	161	65	79	137	163	67	91	138	163	
			$n_{2 \text{ th}}$		135	161	65	79	137	142	67	91	119	123	
28.389	607	0.86	M_2		170	106	328	180	295	145	592	294		259	
			c		3	4.5	1.8	3.3	1.8	3.3	1	2		1.9	
			$n_{2 \text{ Eck}}$		120	143	58	71	122	144	59	81		145	
			$n_{2 \text{ th}}$		120	143	58	70	122	126	59	81		110	
32.8	641	0.58	M_2		197	123	379	209	342	168					
			c		2.8	4.1	1.7	3	1.6	3					
			$n_{2 \text{ Eck}}$		104	124	50	61	105	125					
			$n_{2 \text{ th}}$		104	123	50	61	105	109					
36.951	611	0.56	M_2		223	140	428	236	386	190					
			c		2.3	3.5	1.4	2.5	1.4	2.6					
			$n_{2 \text{ Eck}}$		92	110	44	54	94	111					
			$n_{2 \text{ th}}$		92	110	44	54	94	97					
40.8	657	0.43	M_2		246	154	473	261	426	210					
			c		2.3	3.4	1.4	2.5	1.3	2.5					
			$n_{2 \text{ Eck}}$		84	99	40	49	85	101					
			$n_{2 \text{ th}}$		84	99	40	49	85	88					

$M \dots$ [Nm]
 $n \dots$ [min^{-1}]
 $J \dots$ [kgcm^2]

$P \dots$ [kW]
 $I \dots$ [A]
 i [-]
 c [-]

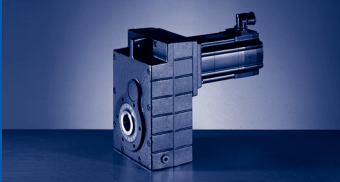

GFL [Nm]

GFL□□-□A (MCA)

$M_{2GN} \leq 660 \text{ Nm}$

GFL06-2A				10IC40	13IC34	13IC41	14LC16	14LC20	14LC35	14LC41	17NC17	17NC23	17NC35	17NC41
				...S00	...F10	...S00	...F10	...S00	...F10	...S00	...F10	...S00	...F10	...S00
i	M_{2GN}	J_G	M_1	2	6.3	4	12	6.7	10.8	5.4	21.5	10.8	19	9.5
			n_1	3950	3410	4050	1635	2000	3455	4100	1680	2300	3480	4110
			I_{M400}	2.4	6	4.4	4.8	3.3	9.1	5.8	8.5	5.5	15.8	10.2
			P_N	0.8	2.2	1.7	2.1	1.4	3.9	2.3	3.8	2.6	6.9	4.1
			J_M	2.44	8.34	8.34	19.32	19.24	19.24	19.24	36.04	36.04	36.04	36.04
45.963	613	0.41	M_2	85	278	175	534	296	481	238				
			c	5.7	1.9	2.8	1.2	2.1	1.1	2.1				
			$n_{2 \text{ Eck}}$	86	74	88	36	44	75	89				
			$n_{2 \text{ th}}$	86	74	88	36	44	75	78				
52.8	660	0.26	M_2	98	320	201								
			c	5.3	1.8	2.6								
			$n_{2 \text{ Eck}}$	75	65	77								
			$n_{2 \text{ th}}$	75	65	77								
59.481	615	0.25	M_2	111	362	228								
			c	4.4	1.5	2.2								
			$n_{2 \text{ Eck}}$	66	57	68								
			$n_{2 \text{ th}}$	66	57	68								
64.08	576	0.19	M_2	121	391	246								
			c	3.8	1.3	1.9								
			$n_{2 \text{ Eck}}$	62	53	63								
			$n_{2 \text{ th}}$	62	53	63								
72.189	616	0.19	M_2	136	440	277								
			c	4	1.3	2								
			$n_{2 \text{ Eck}}$	55	47	56								
			$n_{2 \text{ th}}$	55	47	56								
81	435	0.13	M_2	155										
			c	2.5										
			$n_{2 \text{ Eck}}$	49										
			$n_{2 \text{ th}}$	49										
91.25	476	0.12	M_2	174										
			c	2.5										
			$n_{2 \text{ Eck}}$	43										
			$n_{2 \text{ th}}$	43										

$M \dots$ [Nm]
 $n \dots$ [min^{-1}]
 $J \dots$ [kgcm^2]

$P \dots$ [kW]
 $I \dots$ [A]
 i [-]
 c [-]

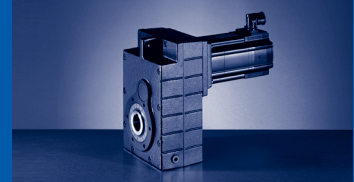

$M_{2GN} \leq 634 \text{ Nm}$

GFL06-3A				10IC40	13IC34	13IC41
				...500	...F10	...500
i	M_{2GN}	J_G	M_1			
			n_1	2	6.3	4
			I_{M400}	3950	3410	4050
			P_N	2.4	6	4.4
			J_M	0.8	2.2	1.7
			M_2	2.44	8.34	8.34
66.213	497	0.29	c	123	398	251
			$n_2 \text{ Eck}$	3.6	1.2	1.8
			$n_2 \text{ th}$	60	52	61
			$n_2 \text{ th}$	60	52	61
72	497	0.26	M_2	134	433	273
			c	3.3	1.1	1.6
			$n_2 \text{ Eck}$	55	47	56
			$n_2 \text{ th}$	55	47	56
81.111	497	0.26	M_2	152		309
			c	2.9		1.5
			$n_2 \text{ Eck}$	49		50
			$n_2 \text{ th}$	49		50
88.2	488	0.19	M_2	166		336
			c	2.6		1.3
			$n_2 \text{ Eck}$	45		46
			$n_2 \text{ th}$	45		46
99.361	550	0.19	M_2	187		379
			c	2.6		1.3
			$n_2 \text{ Eck}$	40		41
			$n_2 \text{ th}$	40		41
116.571	528	0.09	M_2	220		
			c	2.2		
			$n_2 \text{ Eck}$	34		
			$n_2 \text{ th}$	34		
131.323	595	0.21	M_2	248		502
			c	2.2		1.1
			$n_2 \text{ Eck}$	30		31
			$n_2 \text{ th}$	30		31
144.32	560	0.11	M_2	273		
			c	1.9		
			$n_2 \text{ Eck}$	27		
			$n_2 \text{ th}$	27		
162.583	613	0.11	M_2	308		
			c	1.8		
			$n_2 \text{ Eck}$	24		
			$n_2 \text{ th}$	24		
179.52	605	0.1	M_2	341		
			c	1.6		
			$n_2 \text{ Eck}$	22		
			$n_2 \text{ th}$	22		
202.237	611	0.1	M_2	385		
			c	1.4		
			$n_2 \text{ Eck}$	20		
			$n_2 \text{ th}$	20		
231.2	634	0.07	M_2	440		
			c	1.3		
			$n_2 \text{ Eck}$	17		
			$n_2 \text{ th}$	17		
260.457	613	0.07	M_2	497		
			c	1.1		
			$n_2 \text{ Eck}$	15		
			$n_2 \text{ th}$	15		

M ... [Nm]
n ... [min^{-1}]
J ... [kgcm^2]

P ... [kW]
I ... [A]
i [-]
c [-]

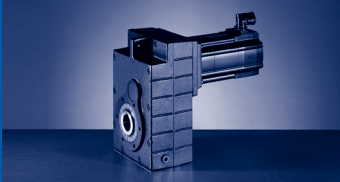

GFL [Nm]

GFL□□-□A (MCA)

$M_{2GN} \leq 1378 \text{ Nm}$

GFL07-2A				10IC40	13IC34	13IC41	14LC16	14LC20	14LC35	14LC41	17NC17	
				...S00	...F10	...S00	...F10	...S00	...F10	...S00	...F10	
i	M_{2GN}	J_G	M_1	2	6.3	4	12	6.7	10.8	5.4	21.5	
			n_1	3950	3410	4050	1635	2000	3455	4100	1680	
			I_{M400}	2.4	6	4.4	4.8	3.3	9.1	5.8	8.5	
			P_N	0.8	2.2	1.7	2.1	1.4	3.9	2.3	3.8	
			J_M	2.44	8.34	8.34	19.32	19.24	19.24	19.24	36.04	
3.35	349	19.57	M_2								67	
			c								4.8	
			n_2 Eck									502
			n_2 th									502
3.35	639	19.57	M_2									
			c									
			n_2 Eck									
			n_2 th									
4.643	483	11.99	M_2								93	
			c								4.8	
			n_2 Eck									362
			n_2 th									362
4.643	653	11.99	M_2									
			c									
			n_2 Eck									
			n_2 th									
5.159	537	11.12	M_2								103	
			c								4.8	
			n_2 Eck									326
			n_2 th									326
5.159	850	11.12	M_2									
			c									
			n_2 Eck									
			n_2 th									
5.695	592	18.09	M_2								114	
			c								4.8	
			n_2 Eck									295
			n_2 th									295
5.695	914	18.09	M_2									
			c									
			n_2 Eck									
			n_2 th									
6.4	463	9.83	M_2						64			
			c						5.2			
			n_2 Eck						540			
			n_2 th						466			
6.4	541	9.83	M_2								130	
			c								3.9	
			n_2 Eck									263
			n_2 th									263
6.4	662	9.83	M_2									
			c									
			n_2 Eck									
			n_2 th									
7.15	744	11.88	M_2								143	
			c								4.8	
			n_2 Eck									235
			n_2 th									235
7.15	918	11.88	M_2									
			c									
			n_2 Eck									
			n_2 th									

$M \dots$ [Nm]
 $n \dots$ [min^{-1}]
 $J \dots$ [kgcm^2]

$P \dots$ [kW]
 $I \dots$ [A]
 i [-]
 c [-]

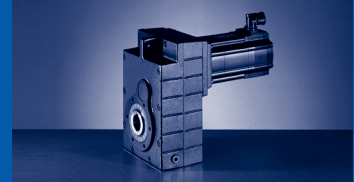

$M_{2GN} \leq 1378 \text{ Nm}$

17NC35	17NC41	19SC17	19SC35	19SC42	21XC17	21XC25	21XC35	21XC42	GFL07-2A			
...F10	...S00	...F10	...F10	...S00	...F10	...S00	...F10	...S00				
19	9.5	36.3	36	12	61.4	24.6	55	17	M_1	J_G	M_{2GN}	i
3480	4110	1700	3510	4150	1710	2490	3520	4160	n_1			
15.8	10.2	13.9	28.7	14	22.5	13.5	42.5	19.8	I_{M400}			
6.9	4.1	6.4	13.2	5.2	11	6.4	20.3	7.4	P_N			
36.04	36.04	72.12	72.04	72.12	180.04	180.04	180.04	180.04	J_M			
60									M_2			
4.3									c			
1039									$n_{2 \text{ Eck}}$	19.57	349	3.35
631									$n_{2 \text{ th}}$			
		113	113		195		176		M_2			
		5.2	4.1		3.1		2.7		c			
		508	1048		511		1051		$n_{2 \text{ Eck}}$	19.57	639	3.35
		508	626		510		567		$n_{2 \text{ th}}$			
83									M_2			
4.3									c			
750									$n_{2 \text{ Eck}}$	11.99	483	4.643
524									$n_{2 \text{ th}}$			
		159	159		273	106	245		M_2			
		3.8	3		2.3	5	2		c			
		366	756		368	536	758		$n_{2 \text{ Eck}}$	11.99	653	4.643
		366	487		368	434	434		$n_{2 \text{ th}}$			
92									M_2			
4.3									c			
675									$n_{2 \text{ Eck}}$	11.12	537	5.159
410									$n_{2 \text{ th}}$			
		175	175		302	117	272		M_2			
		4.5	3.6		2.7	5.8	2.3		c			
		330	680		332	483	682		$n_{2 \text{ Eck}}$	11.12	850	5.159
		330	393		331	390	354		$n_{2 \text{ th}}$			
101									M_2			
4.3									c			
611									$n_{2 \text{ Eck}}$	18.09	592	5.695
371									$n_{2 \text{ th}}$			
		194	194		334	129	300		M_2			
		4.4	3.5		2.6	5.7	2.3		c			
		299	616		300	437	618		$n_{2 \text{ Eck}}$	18.09	914	5.695
		299	354		300	354	319		$n_{2 \text{ th}}$			
									M_2			
									c			
									$n_{2 \text{ Eck}}$	9.83	463	6.4
									$n_{2 \text{ th}}$			
115									M_2			
3.5									c			
544									$n_{2 \text{ Eck}}$	9.83	541	6.4
429									$n_{2 \text{ th}}$			
		221	221		379	149	340	102	M_2			
		2.8	2.2		1.7	3.7	1.5	4.5	c			
		266	548		267	389	550	650	$n_{2 \text{ Eck}}$	9.83	662	6.4
		266	383		267	315	315	315	$n_{2 \text{ th}}$			
127									M_2			
4.3									c			
487									$n_{2 \text{ Eck}}$	11.88	744	7.15
341									$n_{2 \text{ th}}$			
		245	245		421	164	378	112	M_2			
		3.5	2.8		2.1	4.6	1.8	5.5	c			
		238	491		239	348	492	582	$n_{2 \text{ Eck}}$	11.88	918	7.15
		238	310		239	282	271	282	$n_{2 \text{ th}}$			

M ... [Nm]
n ... [min⁻¹]
J ... [kgcm²]

P ... [kW]
I ... [A]
i [-]
c [-]

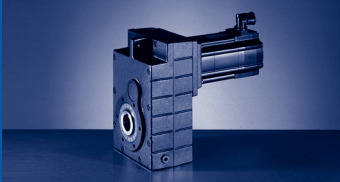

GFL [Nm]

GFL□□-□A (MCA)

$M_{2GN} \leq 1378 \text{ Nm}$

GFL07-2A				10IC40	13IC34	13IC41	14LC16	14LC20	14LC35	14LC41	17NC17	
				...S00	...F10	...S00	...F10	...S00	...F10	...S00	...F10	
i	M_{2GN}	J_G	M_1	2	6.3	4	12	6.7	10.8	5.4	21.5	
			n_1	3950	3410	4050	1635	2000	3455	4100	1680	
			I_{M400}	2.4	6	4.4	4.8	3.3	9.1	5.8	8.5	
			P_N	0.8	2.2	1.7	2.1	1.4	3.9	2.3	3.8	
			J_M	2.44	8.34	8.34	19.32	19.24	19.24	19.24	36.04	
8.324	866	13.11	M_2								167	
			c								4.8	
			n_2 Eck									202
			n_2 th									202
8.324	993	13.11	M_2									
			c									
			n_2 Eck									
			n_2 th									
9.379	976	12.04	M_2								188	
			c								4.8	
			n_2 Eck								179	
			n_2 th								179	
9.379	999	12.04	M_2									
			c									
			n_2 Eck									
			n_2 th									
9.714	757	8.03	M_2						97			
			c						5.6			
			n_2 Eck						356			
			n_2 th						300			
9.714	885	8.03	M_2								196	
			c								4.2	
			n_2 Eck								173	
			n_2 th								173	
9.714	969	8.03	M_2									
			c									
			n_2 Eck									
			n_2 th									
11.538	1080	8.52	M_2								232	
			c								4.3	
			n_2 Eck								146	
			n_2 th								146	
13	1089	7.97	M_2								263	
			c								3.9	
			n_2 Eck								129	
			n_2 th								129	
14.2	1106	6.35	M_2						142			
			c						5.6			
			n_2 Eck						243			
			n_2 th						205			
14.2	1143	6.35	M_2								288	
			c								3.7	
			n_2 Eck								118	
			n_2 th								118	
15.904	1150	5.27	M_2						159			
			c						5.2			
			n_2 Eck						217			
			n_2 th						187			
15.904	1179	5.27	M_2								323	
			c								3.4	
			n_2 Eck								106	
			n_2 th								106	

$M \dots$ [Nm]
 $n \dots$ [min^{-1}]
 $J \dots$ [kgcm^2]

$P \dots$ [kW]
 $I \dots$ [A]
 $i \dots$ [-]
 $c \dots$ [-]

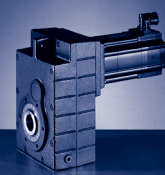

$M_{2GN} \leq 1378 \text{ Nm}$

17NC35	17NC41	19SC17	19SC35	19SC42	21XC17	21XC25	21XC35	21XC42	GFL07-2A			
...F10	...S00	...F10	...F10	...S00	...F10	...S00	...F10	...S00	M_1	J_G	M_{2GN}	i
19	9.5	36.3	36	12	61.4	24.6	55	17	n_1			
3480	4110	1700	3510	4150	1710	2490	3520	4160	I_{M400}			
15.8	10.2	13.9	28.7	14	22.5	13.5	42.5	19.8	P_N			
6.9	4.1	6.4	13.2	5.2	11	6.4	20.3	7.4	J_M			
36.04	36.04	72.12	72.04	72.12	180.04	180.04	180.04	180.04	M_2			
148									c			
4.3									$n_{2 \text{ Eck}}$	13.11	866	8.324
418									$n_{2 \text{ th}}$			
254									M_2			
		286	286		491	192	441	131	c			
		3.3	2.6		1.9	4.2	1.7	5.2	$n_{2 \text{ Eck}}$	13.11	993	8.324
		204	422		205	299	423	500	$n_{2 \text{ th}}$			
		204	225		205	242	191	242	M_2			
167									c			
4.3									$n_{2 \text{ Eck}}$	12.04	976	9.379
371									$n_{2 \text{ th}}$			
225									M_2			
		324	323		555	217	498	149	c			
		2.9	2.3		1.7	3.8	1.5	4.6	$n_{2 \text{ Eck}}$	12.04	999	9.379
		181	374		182	266	375	444	$n_{2 \text{ th}}$			
		181	194		171	215	159	215	M_2			
									c			
									$n_{2 \text{ Eck}}$	8.03	757	9.714
									$n_{2 \text{ th}}$			
174									M_2			
3.7									c	8.03	885	9.714
358									$n_{2 \text{ Eck}}$			
276									$n_{2 \text{ th}}$			
		336	335		575	226	516	155	M_2			
		2.7	2.2		1.6	3.5	1.4	4.3	c			
		175	361		176	256	362	428	$n_{2 \text{ Eck}}$	8.03	969	9.714
		175	243		176	207	195	207	$n_{2 \text{ th}}$			
206		400	399	128	684	269	614	184	M_2			
3.8		2.6	2	5.7	1.5	3.3	1.3	4	c			
302		147	304	360	148	216	305	361	$n_{2 \text{ Eck}}$	8.52	1080	11.538
206		147	178	212	148	175	141	175	$n_{2 \text{ th}}$			
234		452	450	145	772	304	692	209	M_2			
3.4		2.3	1.8	5.1	1.4	3	1.2	3.6	c			
268		131	270	319	132	192	271	320	$n_{2 \text{ Eck}}$	7.97	1089	13
179		131	149	188	126	155	118	155	$n_{2 \text{ th}}$			
									M_2			
									c	6.35	1106	14.2
									$n_{2 \text{ Eck}}$			
									$n_{2 \text{ th}}$			
256		494	492	159	843	332	757	228	M_2			
3.3		2.2	1.7	4.9	1.3	2.9	1.1	3.5	c			
245		120	247	292	120	175	248	293	$n_{2 \text{ Eck}}$	6.35	1143	14.2
184		120	151	172	120	142	120	142	$n_{2 \text{ th}}$			
									M_2			
									c	5.27	1150	15.904
									$n_{2 \text{ Eck}}$			
									$n_{2 \text{ th}}$			
287	139	554	552	178	946	373	848	256	M_2			
3	5.8	2	1.6	4.5	1.2	2.6	1.1	3.2	c			
219	258	107	221	261	108	157	221	262	$n_{2 \text{ Eck}}$	5.27	1179	15.904
168	191	107	135	154	108	127	110	127	$n_{2 \text{ th}}$			

M ... [Nm]
n ... [min⁻¹]
J ... [kgcm²]

P ... [kW]
I ... [A]
i [-]
c [-]

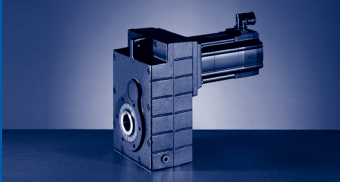

GFL [Nm]

GFL□□-□A (MCA)

$M_{2GN} \leq 1378 \text{ Nm}$

GFL07-2A				10IC40	13IC34	13IC41	14LC16	14LC20	14LC35	14LC41	17NC17
				...S00	...F10	...S00	...F10	...S00	...F10	...S00	...F10
i	M_{2GN}	J_G	M_1	2	6.3	4	12	6.7	10.8	5.4	21.5
			n_1	3950	3410	4050	1635	2000	3455	4100	1680
			I_{M400}	2.4	6	4.4	4.8	3.3	9.1	5.8	8.5
			P_N	0.8	2.2	1.7	2.1	1.4	3.9	2.3	3.8
			J_M	2.44	8.34	8.34	19.32	19.24	19.24	19.24	36.04
17.92	1189	4.98	M_2				199		180		366
			c			5.5		4.8		3.1	
			n_2 Eck			91		193		94	
			n_2 th			91		164		94	
20.286	828	3.47	M_2		119						
			c		5.1						
			n_2 Eck		168						
			n_2 th		168						
20.286	1233	3.47	M_2				226		205		
			c				5.1		4.4		
			n_2 Eck				81		170		
			n_2 th				81		166		
20.286	1262	3.47	M_2								415
			c								2.9
			n_2 Eck								83
			n_2 th								83
22.857	933	3.27	M_2		134						
			c		5.1						
			n_2 Eck		149						
			n_2 th		149						
22.857	1240	3.27	M_2				256		232		469
			c				4.5		3.9		2.5
			n_2 Eck				72		151		74
			n_2 th				72		144		74
24.85	1295	2.65	M_2				279		252		
			c				4.5		4.3		
			n_2 Eck				66		139		
			n_2 th				66		139		
24.85	1337	2.65	M_2								510
			c								2.6
			n_2 Eck								68
			n_2 th								68
28	1242	2.53	M_2				317		285		577
			c				3.8		3.6		2.1
			n_2 Eck				58		123		60
			n_2 th				58		123		60
32.344	1048	1.69	M_2		190						
			c		4.6						
			n_2 Eck		105						
			n_2 th		105						
32.344	1358	1.69	M_2				366		330		
			c				3.6		3.5		
			n_2 Eck				51		107		
			n_2 th				51		107		
32.344	1370	1.69	M_2								668
			c								2
			n_2 Eck								52
			n_2 th								52
36.444	1181	1.61	M_2		215						
			c		4.6						
			n_2 Eck		94						
			n_2 th		94						

$M \dots$ [Nm]
 $n \dots$ [min^{-1}]
 $J \dots$ [kgcm^2]

$P \dots$ [kW]
 $I \dots$ [A]
 i [-]
 c [-]

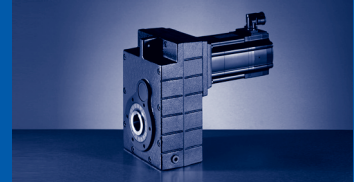

$M_{2GN} \leq 1378 \text{ Nm}$

17NC35	17NC41	19SC17	19SC35	19SC42	21XC17	21XC25	21XC35	21XC42	GFL07-2A			
...F10	...S00	...F10	...F10	...S00	...F10	...S00	...F10	...S00				
19	9.5	36.3	36	12	61.4	24.6	55	17	M_1	J_G	M_{2GN}	i
3480	4110	1700	3510	4150	1710	2490	3520	4160	n_1			
15.8	10.2	13.9	28.7	14	22.5	13.5	42.5	19.8	I_{M400}			
6.9	4.1	6.4	13.2	5.2	11	6.4	20.3	7.4	P_N			
36.04	36.04	72.12	72.04	72.12	180.04	180.04	180.04	180.04	J_M			
324	158	626	623	202	1067	422		290	M_2			
2.7	5.2	1.8	1.4	4.1	1.1	2.4		2.9	c	4.98	1189	17.92
194	229	95	196	232	95	139		232	$n_{2 \text{ Eck}}$			
146	166	95	113	137	95	112		112	$n_{2 \text{ th}}$			
									M_2			
									c	3.47	828	20.286
									$n_{2 \text{ Eck}}$			
									$n_{2 \text{ th}}$			
									M_2			
									c	3.47	1233	20.286
									$n_{2 \text{ Eck}}$			
									$n_{2 \text{ th}}$			
368	180	709	706	229					M_2			
2.6	4.8	1.7	1.3	3.8					c	3.47	1262	20.286
172	203	84	173	205					$n_{2 \text{ Eck}}$			
149	153	84	113	121					$n_{2 \text{ th}}$			
									M_2			
									c	3.27	933	22.857
									$n_{2 \text{ Eck}}$			
									$n_{2 \text{ th}}$			
416	204	801	797	260					M_2			
2.2	4.2	1.5	1.2	3.3					c	3.27	1240	22.857
152	180	74	154	182					$n_{2 \text{ Eck}}$			
128	136	74	94	107					$n_{2 \text{ th}}$			
									M_2			
									c	2.65	1295	24.85
									$n_{2 \text{ Eck}}$			
									$n_{2 \text{ th}}$			
451	220	870	865	281					M_2			
2.5	4.7	1.5	1.3	3.7					c	2.65	1337	24.85
140	165	68	141	167					$n_{2 \text{ Eck}}$			
125	125	68	99	99					$n_{2 \text{ th}}$			
510	250	983	977	319					M_2			
2.1	3.9	1.3	1.1	3.1					c	2.53	1242	28
124	147	61	125	148					$n_{2 \text{ Eck}}$			
111	111	61	84	87					$n_{2 \text{ th}}$			
									M_2			
									c	1.69	1048	32.344
									$n_{2 \text{ Eck}}$			
									$n_{2 \text{ th}}$			
									M_2			
									c	1.69	1358	32.344
									$n_{2 \text{ Eck}}$			
									$n_{2 \text{ th}}$			
590	290								M_2			
2	3.7								c	1.69	1370	32.344
108	127								$n_{2 \text{ Eck}}$			
96	96								$n_{2 \text{ th}}$			
									M_2			
									c	1.61	1181	36.444
									$n_{2 \text{ Eck}}$			
									$n_{2 \text{ th}}$			

$M \dots$ [Nm]
 $n \dots$ [min^{-1}]
 $J \dots$ [kgcm^2]

$P \dots$ [kW]
 $I \dots$ [A]
 $i [-]$
 $c [-]$

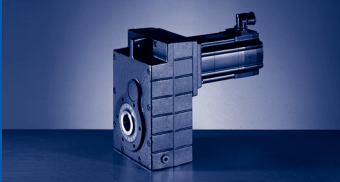

GFL [Nm]

GFL□□-□A (MCA)

$M_{2GN} \leq 1378 \text{ Nm}$

GFL07-2A				10IC40	13IC34	13IC41	14LC16	14LC20	14LC35	14LC41	17NC17
				...S00	...F10	...S00	...F10	...S00	...F10	...S00	...F10
i	M_{2GN}	J_G	M_1	2	6.3	4	12	6.7	10.8	5.4	21.5
			n_1	3950	3410	4050	1635	2000	3455	4100	1680
			I_{M400}	2.4	6	4.4	4.8	3.3	9.1	5.8	8.5
			P_N	0.8	2.2	1.7	2.1	1.4	3.9	2.3	3.8
			J_M	2.44	8.34	8.34	19.32	19.24	19.24	19.24	36.04
36.444	1248	1.61	M_2				416	226	375	182	755
			c				2.9	5.3	2.8	5.3	1.6
			$n_{2 \text{ Eck}}$				45	55	95	113	46
			$n_{2 \text{ th}}$				45	55	95	99	46
39.642	1093	1.25	M_2		235	146					
			c		3.9	5.8					
			$n_{2 \text{ Eck}}$		86	102					
			$n_{2 \text{ th}}$		86	102					
39.642	1378	1.25	M_2				452	246	407	198	821
			c				3	5.4	2.9	5.4	1.7
			$n_{2 \text{ Eck}}$				41	51	87	103	42
			$n_{2 \text{ th}}$				41	50	87	91	42
44.667	1231	1.2	M_2		265	165					
			c		3.9	5.8					
			$n_{2 \text{ Eck}}$		76	91					
			$n_{2 \text{ th}}$		76	91					
44.667	1258	1.2	M_2				512	280	462	226	928
			c				2.4	4.3	2.3	4.4	1.4
			$n_{2 \text{ Eck}}$				37	45	77	92	38
			$n_{2 \text{ th}}$				37	45	77	80	38
52.067	1127	0.78	M_2		311	195					
			c		3.1	4.6					
			$n_{2 \text{ Eck}}$		66	78					
			$n_{2 \text{ th}}$		65	78					
52.067	1342	0.78	M_2				599	328	539	264	
			c				2.2	4	2.1	4	
			$n_{2 \text{ Eck}}$				31	38	66	79	
			$n_{2 \text{ th}}$				31	38	66	69	
58.667	1270	0.75	M_2		351	219	677	372	610	300	
			c		3.1	4.6	1.9	3.3	1.8	3.4	
			$n_{2 \text{ Eck}}$		58	69	28	34	59	70	
			$n_{2 \text{ th}}$		58	69	28	34	59	61	
63.19	792	0.57	M_2	117							
			c	5.3							
			$n_{2 \text{ Eck}}$	63							
			$n_{2 \text{ th}}$	63							
63.19	1145	0.57	M_2		380	238					
			c		2.6	3.8					
			$n_{2 \text{ Eck}}$		54	64					
			$n_{2 \text{ th}}$		54	64					
63.19	1240	0.57	M_2				731	402	658	324	
			c				1.7	3	1.6	3.1	
			$n_{2 \text{ Eck}}$				26	32	55	65	
			$n_{2 \text{ th}}$				26	32	55	57	
71.2	893	0.56	M_2	131							
			c	5.9							
			$n_{2 \text{ Eck}}$	56							
			$n_{2 \text{ th}}$	55							
71.2	1280	0.56	M_2		427	267	824	454	741	365	
			c		2.8	4.2	1.5	2.8	1.6	3.1	
			$n_{2 \text{ Eck}}$		48	57	23	28	49	58	
			$n_{2 \text{ th}}$		48	57	23	28	49	50	

$M \dots$ [Nm]
 $n \dots$ [min^{-1}]
 $J \dots$ [kgcm^2]

$P \dots$ [kW]
 $I \dots$ [A]
 i [-]
 c [-]

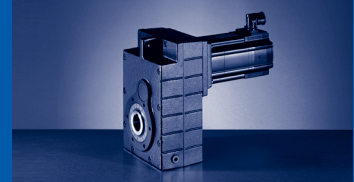

$M_{2GN} \leq 1378 \text{ Nm}$

17NC35	17NC41	19SC17	19SC35	19SC42	21XC17	21XC25	21XC35	21XC42	GFL07-2A			
...F10	...S00	...F10	...F10	...S00	...F10	...S00	...F10	...S00	M_1	J_G	M_{2GN}	i
19	9.5	36.3	36	12	61.4	24.6	55	17	n_1			
3480	4110	1700	3510	4150	1710	2490	3520	4160	I_{M400}			
15.8	10.2	13.9	28.7	14	22.5	13.5	42.5	19.8	P_N			
6.9	4.1	6.4	13.2	5.2	11	6.4	20.3	7.4	J_M			
36.04	36.04	72.12	72.04	72.12	180.04	180.04	180.04	180.04	M_2			
668	329								c			
1.6	3								$n_{2 \text{ Eck}}$	1.61	1248	36.444
96	113								$n_{2 \text{ th}}$			
85	85								M_2			
									c			
									$n_{2 \text{ Eck}}$	1.25	1093	39.642
									$n_{2 \text{ th}}$			
726	358								M_2			
1.6	3.1								c			
88	104								$n_{2 \text{ Eck}}$	1.25	1378	39.642
78	78								$n_{2 \text{ th}}$			
									M_2			
									c			
									$n_{2 \text{ Eck}}$	1.2	1231	44.667
									$n_{2 \text{ th}}$			
821	405								M_2			
1.3	2.5								c			
78	92								$n_{2 \text{ Eck}}$	1.2	1258	44.667
70	70								$n_{2 \text{ th}}$			
									M_2			
									c			
									$n_{2 \text{ Eck}}$	0.78	1127	52.067
									$n_{2 \text{ th}}$			
									M_2			
									c			
									$n_{2 \text{ Eck}}$	0.78	1342	52.067
									$n_{2 \text{ th}}$			
									M_2			
									c			
									$n_{2 \text{ Eck}}$	0.75	1270	58.667
									$n_{2 \text{ th}}$			
									M_2			
									c			
									$n_{2 \text{ Eck}}$	0.57	792	63.19
									$n_{2 \text{ th}}$			
									M_2			
									c			
									$n_{2 \text{ Eck}}$	0.57	1145	63.19
									$n_{2 \text{ th}}$			
									M_2			
									c			
									$n_{2 \text{ Eck}}$	0.57	1240	63.19
									$n_{2 \text{ th}}$			
									M_2			
									c			
									$n_{2 \text{ Eck}}$	0.56	893	71.2
									$n_{2 \text{ th}}$			
									M_2			
									c			
									$n_{2 \text{ Eck}}$	0.56	1280	71.2
									$n_{2 \text{ th}}$			

M ... [Nm]
n ... [min⁻¹]
J ... [kgcm²]

P ... [kW]
I ... [A]
i [-]
c [-]

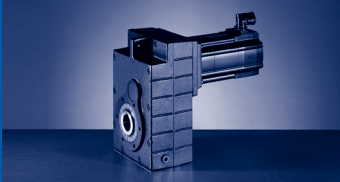

GFL [Nm]

GFL□□-□A (MCA)

$M_{2GN} \leq 1378 \text{ Nm}$

GFL07-2A				10IC40	13IC34	13IC41	14LC16	14LC20	14LC35	14LC41	17NC17
				...S00	...F10	...S00	...F10	...S00	...F10	...S00	...F10
i	M_{2GN}	J_G	M_1	2	6.3	4	12	6.7	10.8	5.4	21.5
			n_1	3950	3410	4050	1635	2000	3455	4100	1680
			I_{M400}	2.4	6	4.4	4.8	3.3	9.1	5.8	8.5
			P_N	0.8	2.2	1.7	2.1	1.4	3.9	2.3	3.8
			J_M	2.44	8.34	8.34	19.32	19.24	19.24	19.24	36.04
79.875	796	0.37	M_2	149							
			c	4.7							
			$n_{2 \text{ Eck}}$	50							
			$n_{2 \text{ th}}$	49							
79.875	854	0.37	M_2		485	305					
			c		1.7	2.5					
			$n_{2 \text{ Eck}}$		43	51					
			$n_{2 \text{ th}}$		43	51					
90	897	0.36	M_2	168							
			c	4.7							
			$n_{2 \text{ Eck}}$	44							
			$n_{2 \text{ th}}$	44							
90	930	0.36	M_2		547	344					
			c		1.6	2.4					
			$n_{2 \text{ Eck}}$		38	45					
			$n_{2 \text{ th}}$		38	45					

M ... [Nm]
 n ... [min^{-1}]
 J ... [kgcm^2]

P ... [kW]
 I ... [A]
 i [-]
 c [-]

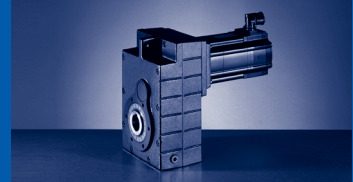

$M_{2GN} \leq 1378 \text{ Nm}$

17NC35	17NC41	19SC17	19SC35	19SC42	21XC17	21XC25	21XC35	21XC42	GFL07-2A			
...F10	...S00	...F10	...F10	...S00	...F10	...S00	...F10	...S00	M_1	J_G	M_{2GN}	i
19	9.5	36.3	36	12	61.4	24.6	55	17	n_1			
3480	4110	1700	3510	4150	1710	2490	3520	4160	I_{M400}			
15.8	10.2	13.9	28.7	14	22.5	13.5	42.5	19.8	P_N			
6.9	4.1	6.4	13.2	5.2	11	6.4	20.3	7.4	J_M			
36.04	36.04	72.12	72.04	72.12	180.04	180.04	180.04	180.04	M_2 c $n_{2 \text{ Eck}}$ $n_{2 \text{ th}}$	0.37	796	79.875
									M_2 c $n_{2 \text{ Eck}}$ $n_{2 \text{ th}}$	0.37	854	79.875
									M_2 c $n_{2 \text{ Eck}}$ $n_{2 \text{ th}}$	0.36	897	90
									M_2 c $n_{2 \text{ Eck}}$ $n_{2 \text{ th}}$	0.36	930	90

M ... [Nm]
n ... [min⁻¹]
J ... [kgcm²]

P ... [kW]
I ... [A]
i [-]
c [-]

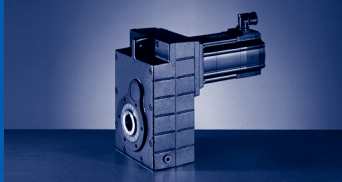

GFL [Nm]

GFL□□-□A (MCA)

$M_{2GN} \leq 1378 \text{ Nm}$

GFL07-3A				10IC40	13IC34	13IC41	14LC16	14LC20	14LC35	14LC41
				...500	...F10	...500	...F10	...500	...F10	...500
i	M_{2GN}	J_G	M_1							
			n_1	2	6.3	4	12	6.7	10.8	5.4
			I_{M400}	3950	3410	4050	1635	2000	3455	4100
			P_N	2.4	6	4.4	4.8	3.3	9.1	5.8
			J_M	0.8	2.2	1.7	2.1	1.4	3.9	2.3
			M_2	2.44	8.34	8.34	19.32	19.24	19.24	19.24
65.306	883	0.79	c		388	244	748	413	672	332
			n_2 Eck		2.2	3.2	1.2	2.1	1.3	2.4
			n_2 th		52	62	25	31	53	63
					52	62	25	31	53	55
72.452	869	0.89	M_2	132	432	272	830	460	747	370
			c	5.7	1.9	2.8	1.1	1.9	1.1	2.1
			n_2 Eck	55	47	56	23	28	48	57
			n_2 th	55	47	56	23	28	47	50
81.636	979	0.88	M_2	148	487	306	936	518	842	416
			c	5.7	1.9	2.8	1.1	1.9	1.1	2.1
			n_2 Eck	48	42	50	20	25	42	50
			n_2 th	48	42	50	20	25	42	44
92.413	961	0.61	M_2	169	553	348		588		473
			c	5	1.7	2.5		1.6		1.8
			n_2 Eck	43	37	44		22		44
			n_2 th	43	37	44		22		39
104.127	1082	0.6	M_2	191	623	392		662		533
			c	5	1.7	2.5		1.6		1.8
			n_2 Eck	38	33	39		19		39
			n_2 th	38	33	39		19		34
113.206	1040	0.45	M_2	209	678	427		722		581
			c	4.4	1.5	2.2		1.4		1.6
			n_2 Eck	35	30	36		18		36
			n_2 th	35	30	36		18		32
127.556	1171	0.44	M_2	235	764	482		813		654
			c	4.4	1.5	2.2		1.4		1.6
			n_2 Eck	31	27	32		16		32
			n_2 th	31	27	32		16		28
147.347	1140	0.28	M_2	274	885	558				
			c	3.7	1.2	1.8				
			n_2 Eck	27	23	28				
			n_2 th	27	23	27				
166.025	1248	0.27	M_2	309	998	629				
			c	3.6	1.2	1.8				
			n_2 Eck	24	21	24				
			n_2 th	24	21	24				
183.285	1236	0.19	M_2	342	1103	696				
			c	3.2	1.1	1.6				
			n_2 Eck	22	19	22				
			n_2 th	22	19	22				
206.519	1248	0.19	M_2	387		786				
			c	2.9		1.4				
			n_2 Eck	19		20				
			n_2 th	19		20				
224.636	1343	0.18	M_2	421		855				
			c	2.9		1.4				
			n_2 Eck	18		18				
			n_2 th	18		18				
253.111	1258	0.18	M_2	477		966				
			c	2.4		1.2				
			n_2 Eck	16		16				
			n_2 th	16		16				

$M \dots$ [Nm]
 $n \dots$ [min^{-1}]
 $J \dots$ [kgcm^2]

$P \dots$ [kW]
 $I \dots$ [A]
 i [-]
 c [-]

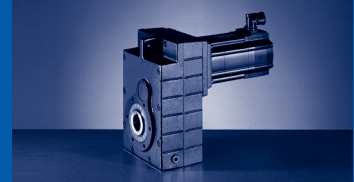

$M_{2GN} \leq 1378 \text{ Nm}$

GFL07-3A				10IC40	13IC34	13IC41	14LC16	14LC20	14LC35	14LC41
				...S00	...F10	...S00	...F10	...S00	...F10	...S00
i	M_{2GN}	J_G	M_1	2	6.3	4	12	6.7	10.8	5.4
			n_1	3950	3410	4050	1635	2000	3455	4100
			I_{M400}	2.4	6	4.4	4.8	3.3	9.1	5.8
			P_N	0.8	2.2	1.7	2.1	1.4	3.9	2.3
			J_M	2.44	8.34	8.34	19.32	19.24	19.24	19.24
290.706	1378	0.11	M_2	548						
			c	2.3						
			n_2 Eck	14						
			n_2 th	14						
327.556	1258	0.11	M_2	621						
			c	1.8						
			n_2 Eck	12						
			n_2 th	12						
352.811	1378	0.08	M_2	668						
			c	1.9						
			n_2 Eck	11						
			n_2 th	11						
397.533	1258	0.08	M_2	756						
			c	1.5						
			n_2 Eck	10						
			n_2 th	10						
430.222	1270	0.1	M_2	819						
			c	1.4						
			n_2 Eck	9						
			n_2 th	9						
522.133	1270	0.08	M_2	996						
			c	1.2						
			n_2 Eck	8						
			n_2 th	8						

$M \dots$ [Nm]
 $n \dots$ [min^{-1}]
 $J \dots$ [kgcm^2]

$P \dots$ [kW]
 $I \dots$ [A]
 $i \dots$ [-]
 $c \dots$ [-]

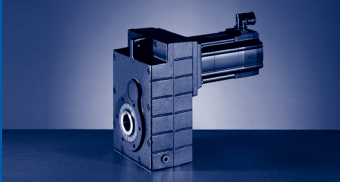

GFL [Nm]

GFL□□-□A (MCA)

$M_{2GN} \leq 3107 \text{ Nm}$

GFL09-2A				14LC16	14LC20	14LC35	14LC41	17NC17	17NC23	17NC35	17NC41
				...F10	...S00	...F10	...S00	...F10	...S00	...F10	...S00
i	M_{2GN}	J_G	M_1	12	6.7	10.8	5.4	21.5	10.8	19	9.5
			n_1	1635	2000	3455	4100	1680	2300	3480	4110
			I_{M400}	4.8	3.3	9.1	5.8	8.5	5.5	15.8	10.2
			P_N	2.1	1.4	3.9	2.3	3.8	2.6	6.9	4.1
			J_M	19.32	19.24	19.24	19.24	36.04	36.04	36.04	36.04
6.864	1662	41.3	M_2 c n_2 Eck n_2 th								
6.864	2089	41.3	M_2 c n_2 Eck n_2 th								
7.466	1807	38.7	M_2 c n_2 Eck n_2 th								
7.466	2156	38.7	M_2 c n_2 Eck n_2 th								
9.01	1037	26.8	M_2 c n_2 Eck n_2 th					180 5.3 187 186		160 4.7 386 252	
9.01	2040	26.8	M_2 c n_2 Eck n_2 th								
9.01	2230	26.8	M_2 c n_2 Eck n_2 th								
9.799	1128	25.3	M_2 c n_2 Eck n_2 th					195 5.3 171 171		174 4.7 355 232	
9.799	2219	25.3	M_2 c n_2 Eck n_2 th								
9.799	2310	25.3	M_2 c n_2 Eck n_2 th								
11.167	1156	19.5	M_2 c n_2 Eck n_2 th					224 4.8 151 150		199 4.2 312 218	
11.167	2303	19.5	M_2 c n_2 Eck n_2 th								
12.307	2223	27.6	M_2 c n_2 Eck n_2 th								

$M \dots$ [Nm]
 $n \dots$ [min^{-1}]
 $J \dots$ [kgcm^2]

$P \dots$ [kW]
 $I \dots$ [A]
 i [-]
 c [-]

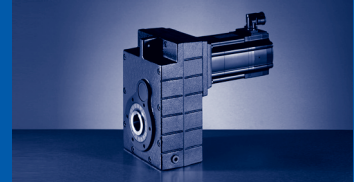

$M_{2GN} \leq 3107 \text{ Nm}$

195C17	195C23	195C35	195C42	21XC17	21XC25	21XC35	21XC42	GFL09-2A			
...F10	...S00	...F10	...S00	...F10	...S00	...F10	...S00	M_1	J_G	M_{2GN}	i
36.3	16.3	36	12	61.4	24.6	55	17	n_1			
1700	2340	3510	4150	1710	2490	3520	4160	I_{M400}			
13.9	8.2	28.7	14	22.5	13.5	42.5	19.8	P_N			
6.4	4	13.2	5.2	11	6.4	20.3	7.4	J_M			
72.12	72.12	72.04	72.12	180.04	180.04	180.04	180.04	M_2			
		229						c			
		5.2						$n_{2 \text{ Eck}}$	41.3	1662	6.864
		511						$n_{2 \text{ th}}$			
		298						M_2			
				393		354		c	41.3	2089	6.864
				4.9		4.3		$n_{2 \text{ Eck}}$			
				249		513		$n_{2 \text{ th}}$			
				249		285		M_2			
		249						c	38.7	1807	7.466
		5.2						$n_{2 \text{ Eck}}$			
		470						$n_{2 \text{ th}}$			
		274						M_2			
				428		386		c	38.7	2156	7.466
				4.6		4.1		$n_{2 \text{ Eck}}$			
				229		472		$n_{2 \text{ th}}$			
				229		259		M_2			
								c	26.8	1037	9.01
								$n_{2 \text{ Eck}}$			
								$n_{2 \text{ th}}$			
		302						M_2			
		4.9						c	26.8	2040	9.01
		390						$n_{2 \text{ Eck}}$			
		254						$n_{2 \text{ th}}$			
				520		468		M_2			
				4		3.5		c	26.8	2230	9.01
				190		391		$n_{2 \text{ Eck}}$			
				190		223		$n_{2 \text{ th}}$			
								M_2			
								c	25.3	1128	9.799
								$n_{2 \text{ Eck}}$			
								$n_{2 \text{ th}}$			
		329						M_2			
		4.9						c	25.3	2219	9.799
		358						$n_{2 \text{ Eck}}$			
		233						$n_{2 \text{ th}}$			
				567		510		M_2			
				3.8		3.3		c	25.3	2310	9.799
				175		359		$n_{2 \text{ Eck}}$			
				175		205		$n_{2 \text{ th}}$			
								M_2			
								c	19.5	1156	11.167
								$n_{2 \text{ Eck}}$			
								$n_{2 \text{ th}}$			
375		376		649		584		M_2			
5.6		4.5		3.3		2.9		c	19.5	2303	11.167
152		314		153		315		$n_{2 \text{ Eck}}$			
152		219		153		180		$n_{2 \text{ th}}$			
416		417		719		646		M_2			
4.9		3.9		2.9		2.6		c	27.6	2223	12.307
138		285		139		286		$n_{2 \text{ Eck}}$			
138		156		139		141		$n_{2 \text{ th}}$			

M ... [Nm]
n ... [min⁻¹]
J ... [kgcm²]

P ... [kW]
I ... [A]
i [-]
c [-]

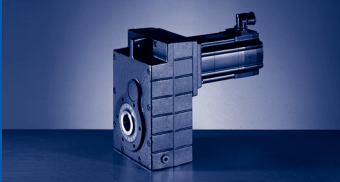

GFL [Nm]

GFL□□-□A (MCA)

$M_{2GN} \leq 3107 \text{ Nm}$

GFL09-2A				14LC16	14LC20	14LC35	14LC41	17NC17	17NC23	17NC35	17NC41
				...F10	...S00	...F10	...S00	...F10	...S00	...F10	...S00
i	M_{2GN}	J_G	M_1								
			n_1	12	6.7	10.8	5.4	21.5	10.8	19	9.5
			I_{M400}	1635	2000	3455	4100	1680	2300	3480	4110
			P_N	4.8	3.3	9.1	5.8	8.5	5.5	15.8	10.2
			J_M	2.1	1.4	3.9	2.3	3.8	2.6	6.9	4.1
			M_2	19.32	19.24	19.24	19.24	36.04	36.04	36.04	36.04
14.333	1650	20	c					286		254	
			n_2 Eck					5.3		4.7	
			n_2 th					117		243	
			n_2 th					117		158	
14.333	2374	20	c								
			n_2 Eck								
			n_2 th								
			n_2 th								
16.333	1692	15.5	M_2					327		291	
			c					4.8		4.2	
			n_2 Eck					103		213	
			n_2 th					103		149	
16.333	2461	15.5	c								
			n_2 Eck								
			n_2 th								
			n_2 th								
18.407	1906	14.6	M_2					369		328	
			c					4.8		4.2	
			n_2 Eck					91		189	
			n_2 th					91		132	
18.407	2480	14.6	c								
			n_2 Eck								
			n_2 th								
			n_2 th								
19.667	1524	12.1	M_2			196					
			c			5.6					
			n_2 Eck			176					
			n_2 th			148					
19.667	1784	12.1	M_2					397		352	
			c					4.2		3.7	
			n_2 Eck					85		177	
			n_2 th					85		136	
19.667	2563	12.1	c								
			n_2 Eck								
			n_2 th								
			n_2 th								
22.164	1717	11.3	M_2			221					
			c			5.6					
			n_2 Eck			156					
			n_2 th			131					
22.164	2010	11.3	M_2					447		397	
			c					4.2		3.7	
			n_2 Eck					76		157	
			n_2 th					76		121	
22.164	2612	11.3	c								
			n_2 Eck								
			n_2 th								
			n_2 th								
24.111	1876	9.04	M_2					489		432	
			c					3.7		3.6	
			n_2 Eck					70		144	
			n_2 th					70		120	

$M \dots$ [Nm]
 $n \dots$ [min^{-1}]
 $J \dots$ [kgcm^2]

$P \dots$ [kW]
 $I \dots$ [A]
 i [-]
 c [-]

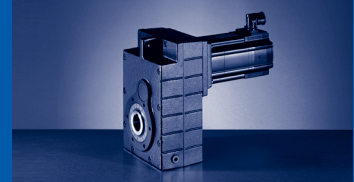

$M_{2GN} \leq 3107 \text{ Nm}$

195C17	195C23	195C35	195C42	21XC17	21XC25	21XC35	21XC42	GFL09-2A			
...F10	...S00	...F10	...S00	...F10	...S00	...F10	...S00	M_1	J_G	M_{2GN}	i
36.3	16.3	36	12	61.4	24.6	55	17	n_1			
1700	2340	3510	4150	1710	2490	3520	4160	I_{M400}			
13.9	8.2	28.7	14	22.5	13.5	42.5	19.8	P_N			
6.4	4	13.2	5.2	11	6.4	20.3	7.4	J_M			
72.12	72.12	72.04	72.12	180.04	180.04	180.04	180.04	M_2 c n_2 Eck n_2 th	20	1650	14.333
487		487		839	325	754		M_2 c n_2 Eck n_2 th	20	2374	14.333
4.5		3.6		2.7	5.9	2.3					
119		245		119	174	246					
119		149		119	140	135					
								M_2 c n_2 Eck n_2 th	15.5	1692	16.333
557		557		959	372	861		M_2 c n_2 Eck n_2 th	15.5	2461	16.333
4.1		3.3		2.4	5.3	2.1					
104		215		105	153	216					
104		140		105	123	123					
								M_2 c n_2 Eck n_2 th	14.6	1906	18.407
630		630		1083	422	973	289	M_2 c n_2 Eck n_2 th	14.6	2480	18.407
3.7		2.9		2.2	4.8	1.9	5.8				
92		191		93	135	191	226				
92		122		93	109	108	109				
								M_2 c n_2 Eck n_2 th	12.1	1524	19.667
								M_2 c n_2 Eck n_2 th	12.1	1784	19.667
674		674		1158	452	1040	309	M_2 c n_2 Eck n_2 th	12.1	2563	19.667
3.6		2.8		2.1	4.6	1.8	5.6				
86		179		87	127	179	212				
86		125		87	102	102	102				
								M_2 c n_2 Eck n_2 th	11.3	1717	22.164
								M_2 c n_2 Eck n_2 th	11.3	2010	22.164
763		762		1308	512	1175	350	M_2 c n_2 Eck n_2 th	11.3	2612	22.164
3.2		2.5		1.9	4.2	1.7	5.1				
77		158		77	112	159	188				
77		110		77	91	91	91				
								M_2 c n_2 Eck n_2 th	9.04	1876	24.111

M ... [Nm]
n ... [min⁻¹]
J ... [kgcm²]

P ... [kW]
I ... [A]
i [-]
c [-]

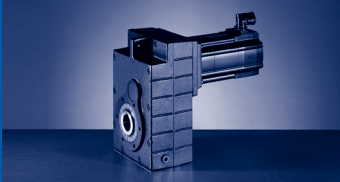

GFL [Nm]

GFL□□-□A (MCA)

$M_{2GN} \leq 3107 \text{ Nm}$

GFL09-2A				14LC16	14LC20	14LC35	14LC41	17NC17	17NC23	17NC35	17NC41
				...F10	...S00	...F10	...S00	...F10	...S00	...F10	...S00
i	M_{2GN}	J_G	M_1	12	6.7	10.8	5.4	21.5	10.8	19	9.5
			n_1	1635	2000	3455	4100	1680	2300	3480	4110
			I_{M400}	4.8	3.3	9.1	5.8	8.5	5.5	15.8	10.2
			P_N	2.1	1.4	3.9	2.3	3.8	2.6	6.9	4.1
			J_M	19.32	19.24	19.24	19.24	36.04	36.04	36.04	36.04
24.111	2722	9.04	M_2 c $n_{2 \text{ Eck}}$ $n_{2 \text{ th}}$								
27.173	2114	8.63	M_2 c $n_{2 \text{ Eck}}$ $n_{2 \text{ th}}$					551 3.7 62 62		487 3.6 128 106	
27.173	2767	8.63	M_2 c $n_{2 \text{ Eck}}$ $n_{2 \text{ th}}$								
32.667	1699	5.43	M_2 c $n_{2 \text{ Eck}}$ $n_{2 \text{ th}}$	367 4.5 50 50		331 4.3 106 106					
32.667	1990	5.43	M_2 c $n_{2 \text{ Eck}}$ $n_{2 \text{ th}}$					668 2.9 51 51	326 5.7 70 70	591 2.8 107 95	288 5.4 126 95
32.667	2990	5.43	M_2 c $n_{2 \text{ Eck}}$ $n_{2 \text{ th}}$								
36.815	1915	5.21	M_2 c $n_{2 \text{ Eck}}$ $n_{2 \text{ th}}$	413 4.5 44 44		373 4.3 94 94					
36.815	2242	5.21	M_2 c $n_{2 \text{ Eck}}$ $n_{2 \text{ th}}$					753 2.9 46 46	367 5.7 63 62	666 2.8 95 85	324 5.4 112 85
36.815	3018	5.21	M_2 c $n_{2 \text{ Eck}}$ $n_{2 \text{ th}}$								
39.667	1761	4.07	M_2 c $n_{2 \text{ Eck}}$ $n_{2 \text{ th}}$	448 3.8 41 41		404 3.7 87 87					
39.667	2061	4.07	M_2 c $n_{2 \text{ Eck}}$ $n_{2 \text{ th}}$					815 2.5 42 42	399 4.9 58 58	721 2.4 88 78	352 4.6 104 78
39.667	3107	4.07	M_2 c $n_{2 \text{ Eck}}$ $n_{2 \text{ th}}$								
44.704	1985	3.92	M_2 c $n_{2 \text{ Eck}}$ $n_{2 \text{ th}}$	505 3.8 37 37		456 3.7 77 77					

$M \dots$ [Nm]
 $n \dots$ [min^{-1}]
 $J \dots$ [kgcm^2]

$P \dots$ [kW]
 $I \dots$ [A]
 i [-]
 c [-]

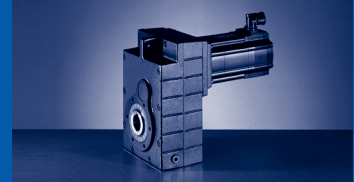

$M_{2GN} \leq 3107 \text{ Nm}$

195C17	195C23	195C35	195C42	21XC17	21XC25	21XC35	21XC42	GFL09-2A			
...F10	...S00	...F10	...S00	...F10	...S00	...F10	...S00	M_1	J_G	M_{2GN}	i
36.3	16.3	36	12	61.4	24.6	55	17	n_1			
1700	2340	3510	4150	1710	2490	3520	4160	I_{M400}			
13.9	8.2	28.7	14	22.5	13.5	42.5	19.8	P_N			
6.4	4	13.2	5.2	11	6.4	20.3	7.4	J_M			
72.12	72.12	72.04	72.12	180.04	180.04	180.04	180.04	M_2			
830		827		1423	554	1276	379	c	9.04	2722	24.111
3.2		2.8		1.9	4.5	1.8	5.5	$n_{2 \text{ Eck}}$			
71		146		71	103	146	173	$n_{2 \text{ th}}$			
71		102		71	84	84	84	M_2			
								c	8.63	2114	27.173
								$n_{2 \text{ Eck}}$			
								$n_{2 \text{ th}}$			
938		934		1607	628	1441	430	M_2			
2.9		2.5		1.7	4.1	1.6	5	c	8.63	2767	27.173
63		129		63	92	130	153	$n_{2 \text{ Eck}}$			
63		90		63	74	74	74	$n_{2 \text{ th}}$			
								M_2			
								c	5.43	1699	32.667
								$n_{2 \text{ Eck}}$			
								$n_{2 \text{ th}}$			
								M_2			
								c	5.43	1990	32.667
								$n_{2 \text{ Eck}}$			
								$n_{2 \text{ th}}$			
1132	492	1126						M_2			
2.6	5.7	2.2						c	5.43	2990	32.667
52	72	108						$n_{2 \text{ Eck}}$			
52	72	75						$n_{2 \text{ th}}$			
								M_2			
								c	5.21	1915	36.815
								$n_{2 \text{ Eck}}$			
								$n_{2 \text{ th}}$			
								M_2			
								c	5.21	2242	36.815
								$n_{2 \text{ Eck}}$			
								$n_{2 \text{ th}}$			
1279	558	1273	408					M_2			
2.3	5.1	2	5.7					c	5.21	3018	36.815
46	64	95	113					$n_{2 \text{ Eck}}$			
46	64	67	67					$n_{2 \text{ th}}$			
								M_2			
								c	4.07	1761	39.667
								$n_{2 \text{ Eck}}$			
								$n_{2 \text{ th}}$			
								M_2			
								c	4.07	2061	39.667
								$n_{2 \text{ Eck}}$			
								$n_{2 \text{ th}}$			
1379	602	1372	441					M_2			
2.2	4.9	1.9	5.5					c	4.07	3107	39.667
43	59	89	105					$n_{2 \text{ Eck}}$			
43	59	62	62					$n_{2 \text{ th}}$			
								M_2			
								c	3.92	1985	44.704
								$n_{2 \text{ Eck}}$			
								$n_{2 \text{ th}}$			

M ... [Nm]
n ... [min⁻¹]
J ... [kgcm²]

P ... [kW]
I ... [A]
i [-]
c [-]

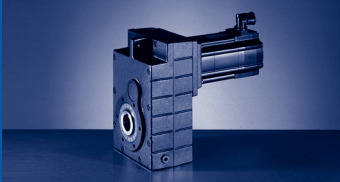

GFL [Nm]

GFL□□-□A (MCA)

$M_{2GN} \leq 3107 \text{ Nm}$

GFL09-2A				14LC16	14LC20	14LC35	14LC41	17NC17	17NC23	17NC35	17NC41
				...F10	...S00	...F10	...S00	...F10	...S00	...F10	...S00
i	M_{2GN}	J_G	M_1	12	6.7	10.8	5.4	21.5	10.8	19	9.5
			n_1	1635	2000	3455	4100	1680	2300	3480	4110
			I_{M400}	4.8	3.3	9.1	5.8	8.5	5.5	15.8	10.2
			P_N	2.1	1.4	3.9	2.3	3.8	2.6	6.9	4.1
			J_M	19.32	19.24	19.24	19.24	36.04	36.04	36.04	36.04
44.704	2323	3.92	M_2					918	450	812	397
			c				2.5	4.9	2.4	4.6	
			$n_{2 \text{ Eck}}$				38	52	78	92	
			$n_{2 \text{ th}}$				38	51	70	70	
44.704	3027	3.92	M_2								
			c								
			$n_{2 \text{ Eck}}$								
			$n_{2 \text{ th}}$								
51.333	1825	2.59	M_2	585	318	527	256				
			c	3.1	5.5	2.9	5.5				
			$n_{2 \text{ Eck}}$	32	39	67	80				
			$n_{2 \text{ th}}$	32	39	67	70				
51.333	2136	2.59	M_2					1060	522	937	460
			c					2	3.9	1.9	3.7
			$n_{2 \text{ Eck}}$					33	45	68	80
			$n_{2 \text{ th}}$					33	45	61	61
57.852	2057	2.5	M_2	659	359	594	289				
			c	3.1	5.5	2.9	5.5				
			$n_{2 \text{ Eck}}$	28	35	60	71				
			$n_{2 \text{ th}}$	28	35	60	62				
57.852	2407	2.5	M_2					1194	588	1056	519
			c					2	3.9	1.9	3.7
			$n_{2 \text{ Eck}}$					29	40	60	71
			$n_{2 \text{ th}}$					29	40	54	54
62.3	1854	1.89	M_2	714	390	643	314				
			c	2.6	4.6	2.4	4.6				
			$n_{2 \text{ Eck}}$	26	32	56	66				
			$n_{2 \text{ th}}$	26	32	55	58				
62.3	2170	1.89	M_2					1291	637	1141	562
			c					1.7	3.3	1.6	3.1
			$n_{2 \text{ Eck}}$					27	37	56	66
			$n_{2 \text{ th}}$					27	37	50	50
70.211	2090	1.83	M_2	804	440	723	352				
			c	2.6	4.6	2.7	5.1				
			$n_{2 \text{ Eck}}$	23	29	49	58				
			$n_{2 \text{ th}}$	23	28	49	51				
70.211	2445	1.83	M_2					1454	718	1284	631
			c					1.7	3.3	1.8	3.4
			$n_{2 \text{ Eck}}$					24	33	50	59
			$n_{2 \text{ th}}$					24	33	44	44
78.75	1631	1.25	M_2	910	500	818	402				
			c	1.8	3.2	1.9	3.6				
			$n_{2 \text{ Eck}}$	21	25	44	52				
			$n_{2 \text{ th}}$	21	25	44	46				
88.75	1781	1.21	M_2	1026	565	922	453				
			c	1.7	3.1	1.8	3.5				
			$n_{2 \text{ Eck}}$	18	23	39	46				
			$n_{2 \text{ th}}$	18	23	39	40				

$M \dots$ [Nm]
 $n \dots$ [min^{-1}]
 $J \dots$ [kgcm^2]

$P \dots$ [kW]
 $I \dots$ [A]
 i [-]
 c [-]

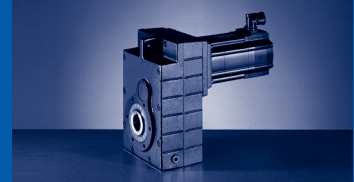

$M_{2GN} \leq 3107 \text{ Nm}$

195C17	195C23	195C35	195C42	21XC17	21XC25	21XC35	21XC42	GFL09-2A			
...F10	...S00	...F10	...S00	...F10	...S00	...F10	...S00	M_1	J_G	M_{2GN}	i
36.3	16.3	36	12	61.4	24.6	55	17	n_1			
1700	2340	3510	4150	1710	2490	3520	4160	I_{M400}			
13.9	8.2	28.7	14	22.5	13.5	42.5	19.8	P_N			
6.4	4	13.2	5.2	11	6.4	20.3	7.4	J_M			
72.12	72.12	72.04	72.12	180.04	180.04	180.04	180.04	M_2 c n_2 Eck n_2 th	3.92	2323	44.704
1559	684	1551	501					M_2 c n_2 Eck n_2 th	3.92	3027	44.704
1.9	4.2	1.7	4.7					M_2 c n_2 Eck n_2 th	2.59	1825	51.333
38	52	79	93					M_2 c n_2 Eck n_2 th	2.59	2136	51.333
38	52	55	55					M_2 c n_2 Eck n_2 th	2.5	2057	57.852
								M_2 c n_2 Eck n_2 th	2.5	2407	57.852
								M_2 c n_2 Eck n_2 th	1.89	1854	62.3
								M_2 c n_2 Eck n_2 th	1.89	2170	62.3
								M_2 c n_2 Eck n_2 th	1.83	2090	70.211
								M_2 c n_2 Eck n_2 th	1.83	2445	70.211
								M_2 c n_2 Eck n_2 th	1.25	1631	78.75
								M_2 c n_2 Eck n_2 th	1.21	1781	88.75

M ... [Nm]
n ... [min^{-1}]
J ... [kgcm^2]

P ... [kW]
I ... [A]
i [-]
c [-]

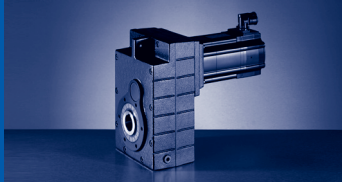

GFL [Nm]

GFL□□-□A (MCA)

$M_{2GN} \leq 3170 \text{ Nm}$

GFL09-3A				10IC40	13IC34	13IC41	14LC16	14LC20	14LC35	14LC41	17NC17	17NC23	17NC35	17NC41
				...S00	...F10	...S00	...F10	...S00	...F10	...S00	...F10	...S00	...F10	...S00
i	M_{2GN}	J_G	M_1	2	6.3	4	12	6.7	10.8	5.4	21.5	10.8	19	9.5
			n_1	3950	3410	4050	1635	2000	3455	4100	1680	2300	3480	4110
			I_{M400}	2.4	6	4.4	4.8	3.3	9.1	5.8	8.5	5.5	15.8	10.2
			P_N	0.8	2.2	1.7	2.1	1.4	3.9	2.3	3.8	2.6	6.9	4.1
			J_M	2.44	8.34	8.34	19.32	19.24	19.24	19.24	36.04	36.04	36.04	36.04
63.326	1510	2.34	M_2		372	232	718	394	647	317	1299	645	1148	568
			c		3.4	5.1	2.1	3.7	2	3.8	1.2	2.3	1.1	2.1
			$n_{2 \text{ Eck}}$		54	64	26	32	55	65	27	36	55	65
			$n_{2 \text{ th}}$		54	64	26	32	55	57	27	36	49	49
73.173	1517	2.47	M_2		430	268	832	458	748	367	1503	747	1327	657
			c		3.3	4.9	1.8	3.2	1.9	3.6	1	2	1.1	2.1
			$n_{2 \text{ Eck}}$		47	55	22	27	47	56	23	31	48	56
			$n_{2 \text{ th}}$		47	55	22	27	47	49	23	31	38	43
82.465	1710	2.43	M_2		485	302	938	516	843	414	1694	842	1496	740
			c		3.3	4.9	1.8	3.2	1.9	3.6	1	2	1.1	2.1
			$n_{2 \text{ Eck}}$		41	49	20	24	42	50	20	28	42	50
			$n_{2 \text{ th}}$		41	49	20	24	42	44	20	28	34	38
93.333	1692	1.68	M_2		551	344	1064	586	957	471		956		840
			c		2.9	4.3	1.6	2.8	1.7	3.2		1.8		1.8
			$n_{2 \text{ Eck}}$		37	43	18	21	37	44		25		44
			$n_{2 \text{ th}}$		37	43	18	21	37	38		25		33
105.185	1907	1.65	M_2		621	388	1199	661	1078	531		1077		947
			c		2.9	4.3	1.6	2.8	1.7	3.2		1.8		1.8
			$n_{2 \text{ Eck}}$		32	39	16	19	33	39		22		39
			$n_{2 \text{ th}}$		32	39	16	19	33	34		22		30
114.333	1847	1.23	M_2		677	424	1306	720	1174	579		1173		1031
			c		2.6	3.8	1.4	2.5	1.5	2.8		1.6		1.6
			$n_{2 \text{ Eck}}$		30	35	14	18	30	36		20		36
			$n_{2 \text{ th}}$		30	35	14	17	30	31		20		27
128.852	2082	1.21	M_2		763	478	1471	812	1323	652		1322		1162
			c		2.6	3.8	1.4	2.5	1.5	2.8		1.6		1.6
			$n_{2 \text{ Eck}}$		27	31	13	16	27	32		18		32
			$n_{2 \text{ th}}$		26	31	13	16	27	28		18		24
148.815	2053	0.77	M_2		885	555	1703	941	1532	757				
			c		2.2	3.3	1.2	2.2	1.3	2.4				
			$n_{2 \text{ Eck}}$		23	27	11	13	23	28				
			$n_{2 \text{ th}}$		23	27	11	13	23	24				
167.712	2314	0.76	M_2		997	626	1919	1061	1726	853				
			c		2.2	3.3	1.2	2.2	1.3	2.4				
			$n_{2 \text{ Eck}}$		20	24	10	12	21	25				
			$n_{2 \text{ th}}$		20	24	10	12	21	21				
185.111	2232	0.55	M_2	336	1104	694	2122	1174	1908	944				
			c	5.8	1.9	2.9	1.1	1.9	1.1	2.1				
			$n_{2 \text{ Eck}}$	21	18	22	9	11	19	22				
			$n_{2 \text{ th}}$	21	18	22	9	11	19	19				
208.617	2515	0.54	M_2	379	1244	782	2391	1323	2151	1064				
			c	5.8	1.9	2.9	1.1	1.9	1.1	2.1				
			$n_{2 \text{ Eck}}$	19	16	19	8	10	17	20				
			$n_{2 \text{ th}}$	19	16	19	8	10	17	17				
224.778	2407	0.51	M_2	411	1343	845		1429		1149				
			c	5.1	1.7	2.5		1.7		1.9				
			$n_{2 \text{ Eck}}$	18	15	18		9		18				
			$n_{2 \text{ th}}$	18	15	18		9		16				
253.321	2712	0.5	M_2	463	1514	953		1611		1295				
			c	5.1	1.7	2.5		1.7		1.9				
			$n_{2 \text{ Eck}}$	16	14	16		8		16				
			$n_{2 \text{ th}}$	16	13	16		8		14				

$M \dots$ [Nm]
 $n \dots$ [min^{-1}]
 $J \dots$ [kgcm^2]

$P \dots$ [kW]
 $I \dots$ [A]
 i [-]
 c [-]

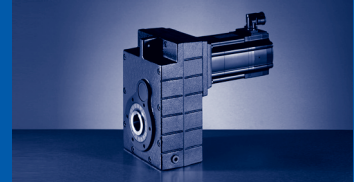

$M_{2GN} \leq 3170 \text{ Nm}$

GFL09-3A				10IC40	13IC34	13IC41	14LC16	14LC20	14LC35	14LC41	17NC17	17NC23	17NC35	17NC41	
				...S00	...F10	...S00	...F10	...S00	...F10	...S00	...F10	...S00	...F10	...S00	
i	M_{2GN}	J_G	M_1	2	6.3	4	12	6.7	10.8	5.4	21.5	10.8	19	9.5	
			n_1	3950	3410	4050	1635	2000	3455	4100	1680	2300	3480	4110	
			I_{M400}	2.4	6	4.4	4.8	3.3	9.1	5.8	8.5	5.5	15.8	10.2	
			P_N	0.8	2.2	1.7	2.1	1.4	3.9	2.3	3.8	2.6	6.9	4.1	
			J_M	2.44	8.34	8.34	19.32	19.24	19.24	19.24	36.04	36.04	36.04	36.04	
290.889	2640	0.31	M_2	537	1743	1099									
			c	4.3	1.5	2.2									
			$n_{2 \text{ Eck}}$	14	12	14									
			$n_{2 \text{ th}}$	14	12	14									
327.827	2976	0.31	M_2	605	1965	1238									
			c	4.3	1.5	2.2									
			$n_{2 \text{ Eck}}$	12	10	12									
			$n_{2 \text{ th}}$	12	10	12									
353.033	2813	0.23	M_2	655	2120	1337									
			c	3.8	1.3	1.9									
			$n_{2 \text{ Eck}}$	11	10	12									
			$n_{2 \text{ th}}$	11	10	11									
397.863	3170	0.22	M_2	738	2389	1507									
			c	3.8	1.3	1.9									
			$n_{2 \text{ Eck}}$	10	9	10									
			$n_{2 \text{ th}}$	10	9	10									
424.247	2724	0.29	M_2	793	2554	1613									
			c	3.1	1	1.5									
			$n_{2 \text{ Eck}}$	9	8	10									
			$n_{2 \text{ th}}$	9	8	10									
514.881	2724	0.21	M_2	968		1963									
			c	2.5		1.3									
			$n_{2 \text{ Eck}}$	8		8									
			$n_{2 \text{ th}}$	8		8									
554.47	2113	0.2	M_2	1051											
			c	1.8											
			$n_{2 \text{ Eck}}$	7											
			$n_{2 \text{ th}}$	7											
624.879	2273	0.2	M_2	1185											
			c	1.7											
			$n_{2 \text{ Eck}}$	6											
			$n_{2 \text{ th}}$	6											
700.875	2113	0.13	M_2	1333											
			c	1.4											
			$n_{2 \text{ Eck}}$	6											
			$n_{2 \text{ th}}$	6											
789.875	2273	0.13	M_2	1504											
			c	1.4											
			$n_{2 \text{ Eck}}$	5											
			$n_{2 \text{ th}}$	5											

M ... [Nm]
n ... [min⁻¹]
J ... [kgcm²]

P ... [kW]
I ... [A]
i [-]
c [-]

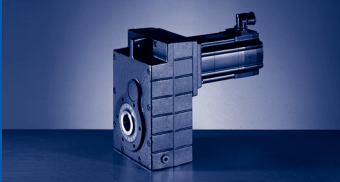

GFL [Nm]

GFL□□-□A (MCA)

$M_{2GN} \leq 5561 \text{ Nm}$

GFL11-2A				14LC16	14LC20	14LC35	14LC41	17NC17	17NC23	17NC35
				...F10	...S00	...F10	...S00	...F10	...S00	...F10
i	M_{2GN}	J_G	M_1							
			n_1	12	6.7	10.8	5.4	21.5	10.8	19
			I_{M400}	4.8	3.3	9.1	5.8	8.5	5.5	15.8
			P_N	2.1	1.4	3.9	2.3	3.8	2.6	6.9
			J_M	19.32	19.24	19.24	19.24	36.04	36.04	36.04
9.01	3570	79.6	M_2 c n_2 Eck n_2 th							
9.799	3767	74.8	M_2 c n_2 Eck n_2 th							
10.72	2595	65	M_2 c n_2 Eck n_2 th							
10.72	3818	65	M_2 c n_2 Eck n_2 th							
12.48	3466	81.5	M_2 c n_2 Eck n_2 th							
14.538	3718	58.4	M_2 c n_2 Eck n_2 th							
15.904	3800	51.3	M_2 c n_2 Eck n_2 th							
17.92	3789	48.3	M_2 c n_2 Eck n_2 th							
20.286	2281	36.1	M_2 c n_2 Eck n_2 th					405 5.2 83 83		360 4.6 172 112
20.286	4045	36.1	M_2 c n_2 Eck n_2 th							
22.857	2570	34.3	M_2 c n_2 Eck n_2 th					456 5.2 74 74		406 4.6 152 99
22.857	4037	34.3	M_2 c n_2 Eck n_2 th							
24.85	4268	26.9	M_2 c n_2 Eck n_2 th							

$M \dots$ [Nm]
 $n \dots$ [min^{-1}]
 $J \dots$ [kgcm^2]

$P \dots$ [kW]
 $I \dots$ [A]
 i [-]
 c [-]

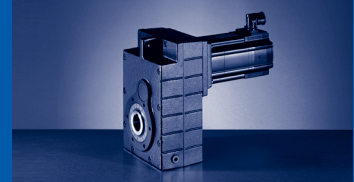

$M_{2GN} \leq 5561 \text{ Nm}$

17NC41	19SC17	19SC23	19SC35	21XC17	21XC25	21XC35	21XC42	GFL11-2A			
...S00	...F10	...S00	...F10	...F10	...S00	...F10	...S00	M_1	J_G	M_{2GN}	i
9.5	36.3	16.3	36	61.4	24.6	55	17	n_1			
4110	1700	2340	3510	1710	2490	3520	4160	I_{M400}			
10.2	13.9	8.2	28.7	22.5	13.5	42.5	19.8	P_N			
4.1	6.4	4	13.2	11	6.4	20.3	7.4	J_M			
36.04	72.12	72.12	72.04	180.04	180.04	180.04	180.04	M_2			
						458		c			
						5.6		$n_{2\text{ Eck}}$	79.6	3570	9.01
						391		$n_{2\text{ th}}$			
						223					
						499		M_2			
						5.4		c	74.8	3767	9.799
						359		$n_{2\text{ Eck}}$			
						205		$n_{2\text{ th}}$			
			358					M_2			
			5.2					c	65	2595	10.72
			327					$n_{2\text{ Eck}}$			
			191					$n_{2\text{ th}}$			
				608		548		M_2			
				5.7		5		c	65	3818	10.72
				160		328		$n_{2\text{ Eck}}$			
				160		188		$n_{2\text{ th}}$			
				717		646		M_2			
				4.5		3.9		c	81.5	3466	12.48
				137		282		$n_{2\text{ Eck}}$			
				132		128		$n_{2\text{ th}}$			
				838		755		M_2			
				4.1		3.6		c	58.4	3718	14.538
				118		242		$n_{2\text{ Eck}}$			
				118		126		$n_{2\text{ th}}$			
			532	920		828		M_2			
			5.2	3.8		3.4		c	51.3	3800	15.904
			221	108		221		$n_{2\text{ Eck}}$			
			128	108		117		$n_{2\text{ th}}$			
	600		603	1041		937		M_2			
	5.8		4.6	3.4		3		c	48.3	3789	17.92
	95		196	95		196		$n_{2\text{ Eck}}$			
	95		111	95		101		$n_{2\text{ th}}$			
								M_2			
								c	36.1	2281	20.286
								$n_{2\text{ Eck}}$			
								$n_{2\text{ th}}$			
	682		684	1181		1062		M_2			
	5.4		4.3	3.2		2.8		c	36.1	4045	20.286
	84		173	84		174		$n_{2\text{ Eck}}$			
	84		110	84		99		$n_{2\text{ th}}$			
								M_2			
								c	34.3	2570	22.857
								$n_{2\text{ Eck}}$			
								$n_{2\text{ th}}$			
	773		775	1336		1201		M_2			
	4.8		3.8	2.8		2.5		c	34.3	4037	22.857
	74		154	75		154		$n_{2\text{ Eck}}$			
	74		95	75		86		$n_{2\text{ th}}$			
	840		839	1452		1302		M_2			
	4.9		4.2	2.9		2.8		c	26.9	4268	24.85
	68		141	69		142		$n_{2\text{ Eck}}$			
	68		99	69		81		$n_{2\text{ th}}$			

M ... [Nm]
n ... [min⁻¹]
J ... [kgcm²]

P ... [kW]
I ... [A]
i [-]
c [-]

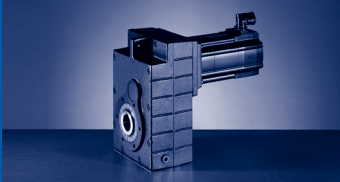

GFL [Nm]

GFL□□-□A (MCA)

$M_{2GN} \leq 5561 \text{ Nm}$

GFL11-2A				14LC16	14LC20	14LC35	14LC41	17NC17	17NC23	17NC35
				...F10	...S00	...F10	...S00	...F10	...S00	...F10
i	M_{2GN}	J_G	M_1							
			n_1	12	6.7	10.8	5.4	21.5	10.8	19
			I_{M400}	4.8	3.3	9.1	5.8	8.5	5.5	15.8
			P_N	2.1	1.4	3.9	2.3	3.8	2.6	6.9
			J_M	19.32	19.24	19.24	19.24	36.04	36.04	36.04
28	4263	25.7	M_2 c n_2 Eck n_2 th							
32.739	2533	17.1	M_2 c n_2 Eck n_2 th					664 3.7 51 51		587 3.6 106 88
32.739	4603	17.1	M_2 c n_2 Eck n_2 th							
36.889	2855	16.5	M_2 c n_2 Eck n_2 th					748 3.7 46 46		662 3.6 94 78
36.889	4601	16.5	M_2 c n_2 Eck n_2 th							
40.233	2607	12.6	M_2 c n_2 Eck n_2 th					821 3.1 42 42		726 3 87 77
40.233	4882	12.6	M_2 c n_2 Eck n_2 th							
45.333	2938	12.2	M_2 c n_2 Eck n_2 th					925 3.1 37 37		818 3 77 69
45.333	4881	12.2	M_2 c n_2 Eck n_2 th							
52.067	2307	8.08	M_2 c n_2 Eck n_2 th	589 3.8 31 31		531 3.6 66 66				
52.067	2701	8.08	M_2 c n_2 Eck n_2 th					1069 2.5 32 32	524 4.9 44 44	946 2.4 67 60
52.067	5251	8.08	M_2 c n_2 Eck n_2 th							
58.667	2599	7.81	M_2 c n_2 Eck n_2 th	663 3.8 28 28		598 3.6 59 59				

$M \dots$ [Nm]
 $n \dots$ [min^{-1}]
 $J \dots$ [kgcm^2]

$P \dots$ [kW]
 $I \dots$ [A]
 i [-]
 c [-]

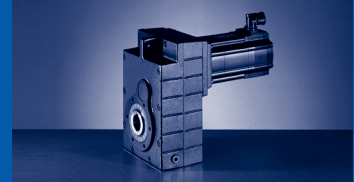

$M_{2GN} \leq 5561 \text{ Nm}$

17NC41	19SC17	19SC23	19SC35	21XC17	21XC25	21XC35	21XC42	GFL11-2A			
...S00	...F10	...S00	...F10	...F10	...S00	...F10	...S00	M_1	J_G	M_{2GN}	i
9.5	36.3	16.3	36	61.4	24.6	55	17	n_1			
4110	1700	2340	3510	1710	2490	3520	4160	I_{M400}			
10.2	13.9	8.2	28.7	22.5	13.5	42.5	19.8	P_N			
4.1	6.4	4	13.2	11	6.4	20.3	7.4	J_M			
36.04	72.12	72.12	72.04	180.04	180.04	180.04	180.04	M_2			
	952		950	1641		1472		c	25.7	4263	28
	4.3		3.7	2.6		2.4		$n_{2 \text{ Eck}}$			
	61		125	61		126		$n_{2 \text{ th}}$			
	61		87	61		72		M_2			
								c	17.1	2533	32.739
								$n_{2 \text{ Eck}}$			
								$n_{2 \text{ th}}$			
	1117		1115	1923	744	1724		M_2			
	4		3.5	2.4	5.7	2.3		c	17.1	4603	32.739
	52		107	52	76	108		$n_{2 \text{ Eck}}$			
	52		75	52	62	62		$n_{2 \text{ th}}$			
								M_2			
								c	16.5	2855	36.889
								$n_{2 \text{ Eck}}$			
								$n_{2 \text{ th}}$			
	1265		1261	2173	844	1948		M_2			
	3.5		3.1	2.1	5	2		c	16.5	4601	36.889
	46		95	46	68	95		$n_{2 \text{ Eck}}$			
	46		66	46	55	55		$n_{2 \text{ th}}$			
353								M_2			
5.7								c	12.6	2607	40.233
102								$n_{2 \text{ Eck}}$			
77								$n_{2 \text{ th}}$			
	1381		1377	2371	922	2126	630	M_2			
	3.5		3	2	4.9	1.9	6	c	12.6	4882	40.233
	42		87	43	62	88	103	$n_{2 \text{ Eck}}$			
	42		61	43	50	50	50	$n_{2 \text{ th}}$			
398								M_2			
5.7								c	12.2	2938	45.333
91								$n_{2 \text{ Eck}}$			
69								$n_{2 \text{ th}}$			
	1563		1557	2678	1045	2401	715	M_2			
	3.1		2.6	1.8	4.3	1.7	5.3	c	12.2	4881	45.333
	38		77	38	55	78	92	$n_{2 \text{ Eck}}$			
	38		54	38	44	44	44	$n_{2 \text{ th}}$			
								M_2			
								c	8.08	2307	52.067
								$n_{2 \text{ Eck}}$			
								$n_{2 \text{ th}}$			
462								M_2			
4.6								c	8.08	2701	52.067
79								$n_{2 \text{ Eck}}$			
60								$n_{2 \text{ th}}$			
	1799		1791					M_2			
	2.9		2.5					c	8.08	5251	52.067
	33		67					$n_{2 \text{ Eck}}$			
	33		47					$n_{2 \text{ th}}$			
								M_2			
								c	7.81	2599	58.667
								$n_{2 \text{ Eck}}$			
								$n_{2 \text{ th}}$			

M ... [Nm]
n ... [min⁻¹]
J ... [kgcm²]

P ... [kW]
I ... [A]
i [-]
c [-]

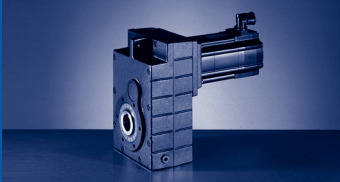

GFL [Nm]

GFL□□-□A (MCA)

$M_{2GN} \leq 5561 \text{ Nm}$

GFL11-2A				14LC16	14LC20	14LC35	14LC41	17NC17	17NC23	17NC35
				...F10	...S00	...F10	...S00	...F10	...S00	...F10
i	M_{2GN}	J_G	M_1	12	6.7	10.8	5.4	21.5	10.8	19
			n_1	1635	2000	3455	4100	1680	2300	3480
			I_{M400}	4.8	3.3	9.1	5.8	8.5	5.5	15.8
			P_N	2.1	1.4	3.9	2.3	3.8	2.6	6.9
			J_M	19.32	19.24	19.24	19.24	36.04	36.04	36.04
58.667	3044	7.81	M_2					1205	590	1066
			c					2.5	4.9	2.4
			$n_{2 \text{ Eck}}$					29	39	59
			$n_{2 \text{ th}}$					29	39	53
58.667	5254	7.81	M_2							
			c							
			$n_{2 \text{ Eck}}$							
			$n_{2 \text{ th}}$							
63.19	2344	5.9	M_2	719	391	648	315			
			c	3.2	5.7	3.1	5.8			
			$n_{2 \text{ Eck}}$	26	32	55	65			
			$n_{2 \text{ th}}$	26	32	55	57			
63.19	2745	5.9	M_2					1303	641	1153
			c					2.1	4.1	2
			$n_{2 \text{ Eck}}$					27	36	55
			$n_{2 \text{ th}}$					27	36	49
63.19	5557	5.9	M_2							
			c							
			$n_{2 \text{ Eck}}$							
			$n_{2 \text{ th}}$							
71.2	2641	5.72	M_2	810	440	728				
			c	3.2	5.7	3.4				
			$n_{2 \text{ Eck}}$	23	28	49				
			$n_{2 \text{ th}}$	23	28	49				
71.2	3093	5.72	M_2					1469	722	1296
			c					2.1	4.2	2.2
			$n_{2 \text{ Eck}}$					24	32	49
			$n_{2 \text{ th}}$					24	32	44
71.2	5561	5.72	M_2							
			c							
			$n_{2 \text{ Eck}}$							
			$n_{2 \text{ th}}$							
79.875	2381	3.87	M_2	915	500	822	401			
			c	2.6	4.6	2.7	5.1			
			$n_{2 \text{ Eck}}$	21	25	43	51			
			$n_{2 \text{ th}}$	20	25	43	45			
79.875	2789	3.87	M_2					1655	817	1460
			c					1.7	3.3	1.8
			$n_{2 \text{ Eck}}$					21	29	44
			$n_{2 \text{ th}}$					21	29	39
90	2683	3.76	M_2	1031	563	926	451			
			c	2.6	4.6	2.7	5.1			
			$n_{2 \text{ Eck}}$	18	22	38	46			
			$n_{2 \text{ th}}$	18	22	38	40			
90	3143	3.76	M_2					1864	920	1645
			c					1.7	3.3	1.8
			$n_{2 \text{ Eck}}$					19	26	39
			$n_{2 \text{ th}}$					19	26	35

$M \dots$ [Nm]
 $n \dots$ [min^{-1}]
 $J \dots$ [kgcm^2]

$P \dots$ [kW]
 $I \dots$ [A]
 i [-]
 c [-]

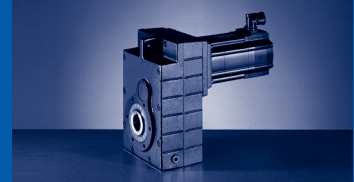

$M_{2GN} \leq 5561 \text{ Nm}$

17NC41	19SC17	19SC23	19SC35	21XC17	21XC25	21XC35	21XC42	GFL11-2A			
...S00	...F10	...S00	...F10	...F10	...S00	...F10	...S00	M_1	J_G	M_{2GN}	i
9.5	36.3	16.3	36	61.4	24.6	55	17	n_1			
4110	1700	2340	3510	1710	2490	3520	4160	I_{M400}			
10.2	13.9	8.2	28.7	22.5	13.5	42.5	19.8	P_N			
4.1	6.4	4	13.2	11	6.4	20.3	7.4	J_M			
36.04	72.12	72.12	72.04	180.04	180.04	180.04	180.04	M_2			
521								c			
4.6								$n_{2 \text{ Eck}}$	7.81	3044	58.667
70								$n_{2 \text{ th}}$			
53								M_2			
	2033	884	2024					c			
	2.5	5.6	2.2					$n_{2 \text{ Eck}}$	7.81	5254	58.667
	29	40	60					$n_{2 \text{ th}}$			
	29	40	42					M_2			
								c			
								$n_{2 \text{ Eck}}$	5.9	2344	63.19
								$n_{2 \text{ th}}$			
565								M_2			
3.8								c			
65								$n_{2 \text{ Eck}}$	5.9	2745	63.19
49								$n_{2 \text{ th}}$			
	2191	954	2181					M_2			
	2.5	5.5	2.2					c			
	27	37	56					$n_{2 \text{ Eck}}$	5.9	5557	63.19
	27	37	39					$n_{2 \text{ th}}$			
								M_2			
								c			
								$n_{2 \text{ Eck}}$	5.72	2641	71.2
								$n_{2 \text{ th}}$			
634								M_2			
4.2								c			
58								$n_{2 \text{ Eck}}$	5.72	3093	71.2
44								$n_{2 \text{ th}}$			
	2476	1080	2458					M_2			
	2.2	4.9	2.1					c			
	24	33	49					$n_{2 \text{ Eck}}$	5.72	5561	71.2
	24	33	34					$n_{2 \text{ th}}$			
								M_2			
								c			
								$n_{2 \text{ Eck}}$	3.87	2381	79.875
								$n_{2 \text{ th}}$			
718								M_2			
3.4								c			
52								$n_{2 \text{ Eck}}$	3.87	2789	79.875
39								$n_{2 \text{ th}}$			
								M_2			
								c			
								$n_{2 \text{ Eck}}$	3.76	2683	90
								$n_{2 \text{ th}}$			
809								M_2			
3.4								c			
46								$n_{2 \text{ Eck}}$	3.76	3143	90
35								$n_{2 \text{ th}}$			

M ... [Nm]
n ... [min⁻¹]
J ... [kgcm²]

P ... [kW]
I ... [A]
i [-]
c [-]

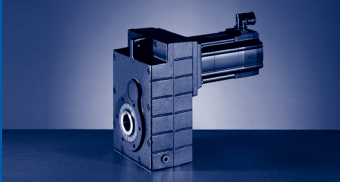

GFL [Nm]

GFL□□-□A (MCA)

$M_{2GN} \leq 5952 \text{ Nm}$

GFL11-3A				10IC40	13IC34	13IC41	14LC16	14LC20	14LC35	14LC41	17NC17
				...S00	...F10	...S00	...F10	...S00	...F10	...S00	...F10
i	M_{2GN}	J_G	M_1	2	6.3	4	12	6.7	10.8	5.4	21.5
			n_1	3950	3410	4050	1635	2000	3455	4100	1680
			I_{M400}	2.4	6	4.4	4.8	3.3	9.1	5.8	8.5
			P_N	0.8	2.2	1.7	2.1	1.4	3.9	2.3	3.8
			J_M	2.44	8.34	8.34	19.32	19.24	19.24	19.24	36.04
65.306	2891	6.97	M_2				727		652		1326
			c				3.9		4.1		2.2
			$n_{2 \text{ Eck}}$				25		53		26
			$n_{2 \text{ th}}$				25		53		26
73.335	2875	7.84	M_2				820		736		1492
			c				3.4		3.6		1.9
			$n_{2 \text{ Eck}}$				22		47		23
			$n_{2 \text{ th}}$				22		47		23
82.631	3240	7.71	M_2				924		829		1682
			c				3.4		3.6		1.9
			$n_{2 \text{ Eck}}$				20		42		20
			$n_{2 \text{ th}}$				20		42		20
93.54	3206	5.05	M_2		537		1050	572	944	458	1909
			c		5.5		3	5.4	3.2	6	1.7
			$n_{2 \text{ Eck}}$		37		18	21	37	44	18
			$n_{2 \text{ th}}$		36		17	21	37	38	18
105.397	3613	4.97	M_2		605		1184	644	1063	516	2150
			c		5.5		3	5.4	3.2	6	1.7
			$n_{2 \text{ Eck}}$		32		16	19	33	39	16
			$n_{2 \text{ th}}$		32		16	19	33	34	16
114.586	3501	3.71	M_2				1291	705	1160	565	2342
			c				2.7	4.8	2.8	5.3	1.5
			$n_{2 \text{ Eck}}$				14	18	30	36	15
			$n_{2 \text{ th}}$				14	17	30	31	15
129.111	3945	3.66	M_2				1455	794	1307	636	2639
			c				2.7	4.8	2.8	5.3	1.5
			$n_{2 \text{ Eck}}$				13	16	27	32	13
			$n_{2 \text{ th}}$				13	15	27	28	13
149.144	3894	2.3	M_2		868		1688	924	1517	741	3056
			c		4.2		2.3	4.1	2.4	4.6	1.3
			$n_{2 \text{ Eck}}$		23		11	13	23	28	11
			$n_{2 \text{ th}}$		23		11	13	23	24	11
168.049	4387	2.27	M_2		978		1901	1041	1709	835	3443
			c		4.2		2.3	4.1	2.4	4.6	1.3
			$n_{2 \text{ Eck}}$		20		10	12	21	24	10
			$n_{2 \text{ th}}$		20		10	12	21	21	10
182.792	4233	1.66	M_2		1070	666	2074	1138	1864	913	3751
			c		3.7	5.5	2	3.6	2.1	4	1.1
			$n_{2 \text{ Eck}}$		19	22	9	11	19	22	9
			$n_{2 \text{ th}}$		19	22	9	11	19	20	9
205.963	4769	1.64	M_2		1205	750	2337	1283	2100	1029	4226
			c		3.7	5.5	2	3.6	2.1	4	1.1
			$n_{2 \text{ Eck}}$		17	20	8	10	17	20	8
			$n_{2 \text{ th}}$		17	20	8	10	17	17	8
224.636	4523	1.52	M_2		1321	825	2556	1406	2298	1129	
			c		3.2	4.8	1.8	3.2	1.9	3.5	
			$n_{2 \text{ Eck}}$		15	18	7	9	15	18	
			$n_{2 \text{ th}}$		15	18	7	9	15	16	
253.111	5097	1.5	M_2		1489	929	2880	1584	2589	1272	
			c		3.2	4.8	1.8	3.2	1.9	3.5	
			$n_{2 \text{ Eck}}$		14	16	7	8	14	16	
			$n_{2 \text{ th}}$		13	16	6	8	14	14	

$M \dots$ [Nm]
 $n \dots$ [min^{-1}]
 $J \dots$ [kgcm^2]

$P \dots$ [kW]
 $I \dots$ [A]
 $i \dots$ [-]
 $c \dots$ [-]

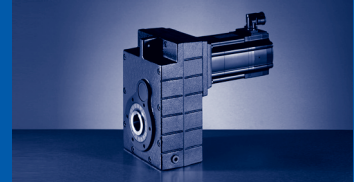

$M_{2GN} \leq 5952 \text{ Nm}$

17NC23	17NC35	17NC41	19SC17	19SC23	19SC35	19SC42	21XC25	21XC42	GFL11-3A			
...S00	...F10	...S00	...F10	...S00	...F10	...S00	...S00	...S00	M_1	J_G	M_{2GN}	i
10.8	19	9.5	36.3	16.3	36	12	24.6	17	n_1			
2300	3480	4110	1700	2340	3510	4150	2490	4160	I_{M400}			
5.5	15.8	10.2	13.9	8.2	28.7	14	13.5	19.8	P_N			
2.6	6.9	4.1	6.4	4	13.2	5.2	6.4	7.4	J_M			
36.04	36.04	36.04	72.12	72.12	72.04	72.12	180.04	180.04	M_2			
651	1169	572	2259	998	2242	730			c	6.97	2891	65.306
4.3	2.3	4.4	1.3	2.8	1.2	3.5			$n_{2 \text{ Eck}}$			
35	53	63	26	36	54	64			$n_{2 \text{ th}}$			
35	48	48	26	36	37	37			M_2			
735	1317	646	2541	1124	2521	823	1712	1177	c	7.84	2875	73.335
3.8	2.1	3.9	1.1	2.5	1.1	3.1	1.7	2.2	$n_{2 \text{ Eck}}$			
31	48	56	23	32	48	57	34	57	$n_{2 \text{ th}}$			
31	42	42	23	32	31	33	27	27	M_2			
828	1484	728	2863	1267	2840	927	1929	1326	c	7.71	3240	82.631
3.8	2.1	3.9	1.1	2.5	1.1	3.1	1.7	2.2	$n_{2 \text{ Eck}}$			
28	42	50	21	28	43	50	30	50	$n_{2 \text{ th}}$			
28	38	38	21	28	28	30	24	24	M_2			
942	1684	828		1439		1054			c	5.05	3206	93.54
3.3	1.8	3.4		2.2		2.7			$n_{2 \text{ Eck}}$			
25	37	44		25		44			$n_{2 \text{ th}}$			
25	33	33		25		26			M_2			
1061	1898	933		1621		1187			c	4.97	3613	105.397
3.3	1.8	3.4		2.2		2.7			$n_{2 \text{ Eck}}$			
22	33	39		22		39			$n_{2 \text{ th}}$			
22	30	30		22		23			M_2			
1158	2068	1018		1767		1295			c	3.71	3501	114.586
3	1.6	3		2		2.4			$n_{2 \text{ Eck}}$			
20	30	36		20		36			$n_{2 \text{ th}}$			
20	27	27		20		21			M_2			
1305	2330	1147		1991		1459			c	3.66	3945	129.111
3	1.6	3		2		2.4			$n_{2 \text{ Eck}}$			
18	27	32		18		32			$n_{2 \text{ th}}$			
18	24	24		18		19			M_2			
1515	2698	1332							c	2.3	3894	149.144
2.5	1.4	2.6							$n_{2 \text{ Eck}}$			
15	23	28							$n_{2 \text{ th}}$			
15	21	21							M_2			
1707	3040	1500							c	2.27	4387	168.049
2.5	1.4	2.6							$n_{2 \text{ Eck}}$			
14	21	25							$n_{2 \text{ th}}$			
14	19	19							M_2			
1862	3312	1637							c	1.66	4233	182.792
2.2	1.2	2.3							$n_{2 \text{ Eck}}$			
13	19	23							$n_{2 \text{ th}}$			
13	17	17							M_2			
2098	3731	1845							c	1.64	4769	205.963
2.2	1.2	2.3							$n_{2 \text{ Eck}}$			
11	17	20							$n_{2 \text{ th}}$			
11	15	15							M_2			
2295	4077	2018							c	1.52	4523	224.636
2	1.1	2							$n_{2 \text{ Eck}}$			
10	16	18							$n_{2 \text{ th}}$			
10	14	14							M_2			
2586	4593	2274							c	1.5	5097	253.111
2	1.1	2							$n_{2 \text{ Eck}}$			
9	14	16							$n_{2 \text{ th}}$			
9	12	12										

M ... [Nm]
n ... [min⁻¹]
J ... [kgcm²]

P ... [kW]
I ... [A]
i [-]
c [-]

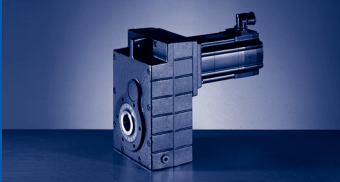

GFL [Nm]

GFL□□-□A (MCA)

$M_{2GN} \leq 5952 \text{ Nm}$

GFL11-3A				10IC40	13IC34	13IC41	14LC16	14LC20	14LC35	14LC41	17NC17
				...S00	...F10	...S00	...F10	...S00	...F10	...S00	...F10
i	M_{2GN}	J_G	M_1	2	6.3	4	12	6.7	10.8	5.4	21.5
			n_1	3950	3410	4050	1635	2000	3455	4100	1680
			I_{M400}	2.4	6	4.4	4.8	3.3	9.1	5.8	8.5
			P_N	0.8	2.2	1.7	2.1	1.4	3.9	2.3	3.8
			J_M	2.44	8.34	8.34	19.32	19.24	19.24	19.24	36.04
267.259	5106	1.87	M_2		1575	984	3044	1676	2736	1346	
			c		3	4.5	1.7	3	1.8	3.3	
			$n_{2 \text{ Eck}}$		13	15	6	8	13	15	
			$n_{2 \text{ th}}$		13	15	6	7	13	13	
327.556	5523	1.37	M_2		1937	1213	3738	2061	3361	1656	
			c		2.7	4	1.5	2.6	1.6	2.9	
			$n_{2 \text{ Eck}}$		10	12	5	6	11	13	
			$n_{2 \text{ th}}$		10	12	5	6	11	11	
358.077	4423	0.68	M_2	649							
			c	5.9							
			$n_{2 \text{ Eck}}$	11							
			$n_{2 \text{ th}}$	11							
358.077	5283	0.68	M_2		2125	1333	4094	2261	3682	1817	
			c		2.4	3.5	1.3	2.3	1.4	2.6	
			$n_{2 \text{ Eck}}$		10	11	5	6	10	12	
			$n_{2 \text{ th}}$		10	11	5	6	10	10	
403.467	4984	0.67	M_2	732							
			c	5.9							
			$n_{2 \text{ Eck}}$	10							
			$n_{2 \text{ th}}$	10							
403.467	5952	0.67	M_2		2395	1502	4613	2548	4148	2048	
			c		2.4	3.5	1.3	2.3	1.4	2.6	
			$n_{2 \text{ Eck}}$		9	10	4	5	9	10	
			$n_{2 \text{ th}}$		8	10	4	5	9	9	
430.222	5942	0.85	M_2		2558	1606	4923	2721	4428	2187	
			c		2.2	3.3	1.2	2.2	1.3	2.4	
			$n_{2 \text{ Eck}}$		8	9	4	5	8	10	
			$n_{2 \text{ th}}$		8	9	4	5	8	8	
522.133	5942	0.62	M_2	952	3117	1961		3316	5386	2667	
			c	5.4	1.8	2.7		1.8	1.1	2	
			$n_{2 \text{ Eck}}$	8	7	8		4	7	8	
			$n_{2 \text{ th}}$	8	7	8		4	7	7	
562.391	5319	0.6	M_2	1035	3368	2122		3583		2883	
			c	4.5	1.5	2.2		1.5		1.7	
			$n_{2 \text{ Eck}}$	7	6	7		4		7	
			$n_{2 \text{ th}}$	7	6	7		4		6	
633.68	5844	0.6	M_2	1168	3797	2392		4039		3249	
			c	4.4	1.5	2.2		1.4		1.6	
			$n_{2 \text{ Eck}}$	6	5	6		3		7	
			$n_{2 \text{ th}}$	6	5	6		3		6	
710.888	5319	0.39	M_2	1322	4272	2696					
			c	3.6	1.2	1.8					
			$n_{2 \text{ Eck}}$	6	5	6					
			$n_{2 \text{ th}}$	6	5	6					
801	5844	0.38	M_2	1491	4814	3039					
			c	3.5	1.2	1.7					
			$n_{2 \text{ Eck}}$	5	4	5					
			$n_{2 \text{ th}}$	5	4	5					

$M \dots$ [Nm]
 $n \dots$ [min^{-1}]
 $J \dots$ [kgcm^2]

$P \dots$ [kW]
 $I \dots$ [A]
 i [-]
 c [-]

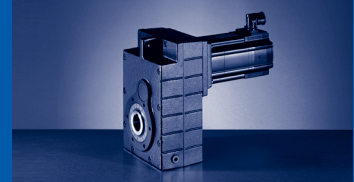

$M_{2GN} \leq 5952 \text{ Nm}$

17NC23	17NC35	17NC41	19SC17	19SC23	19SC35	19SC42	21XC25	21XC42	GFL11-3A			
...S00	...F10	...S00	...F10	...S00	...F10	...S00	...S00	...S00	M_1	J_G	M_{2GN}	i
10.8	19	9.5	36.3	16.3	36	12	24.6	17	n_1			
2300	3480	4110	1700	2340	3510	4150	2490	4160	I_{M400}			
5.5	15.8	10.2	13.9	8.2	28.7	14	13.5	19.8	P_N			
2.6	6.9	4.1	6.4	4	13.2	5.2	6.4	7.4	J_M			
36.04	36.04	36.04	72.12	72.12	72.04	72.12	180.04	180.04	M_2			
2734	4853	2404							c			
1.9	1	1.9							$n_{2 \text{ Eck}}$	1.87	5106	267.259
9	13	15							$n_{2 \text{ th}}$			
9	12	12							M_2			
3358		2953							c			
1.6		1.7							$n_{2 \text{ Eck}}$	1.37	5523	327.556
7		13							$n_{2 \text{ th}}$			
7		10							M_2			
									c			
									$n_{2 \text{ Eck}}$	0.68	4423	358.077
									$n_{2 \text{ th}}$			
									M_2			
									c			
									$n_{2 \text{ Eck}}$	0.68	5283	358.077
									$n_{2 \text{ th}}$			
									M_2			
									c			
									$n_{2 \text{ Eck}}$	0.67	4984	403.467
									$n_{2 \text{ th}}$			
									M_2			
									c			
									$n_{2 \text{ Eck}}$	0.67	5952	403.467
									$n_{2 \text{ th}}$			
									M_2			
									c			
									$n_{2 \text{ Eck}}$	0.85	5942	430.222
									$n_{2 \text{ th}}$			
									M_2			
									c			
									$n_{2 \text{ Eck}}$	0.62	5942	522.133
									$n_{2 \text{ th}}$			
									M_2			
									c			
									$n_{2 \text{ Eck}}$	0.6	5319	562.391
									$n_{2 \text{ th}}$			
									M_2			
									c			
									$n_{2 \text{ Eck}}$	0.6	5844	633.68
									$n_{2 \text{ th}}$			
									M_2			
									c			
									$n_{2 \text{ Eck}}$	0.39	5319	710.888
									$n_{2 \text{ th}}$			
									M_2			
									c			
									$n_{2 \text{ Eck}}$	0.38	5844	801
									$n_{2 \text{ th}}$			

M ... [Nm]
n ... [min⁻¹]
J ... [kgcm²]

P ... [kW]
I ... [A]
i [-]
c [-]

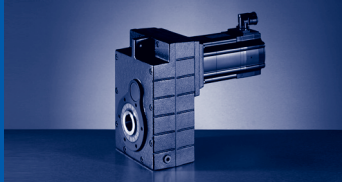

GFL [Nm]

GFL□□-□A (MCA)

$M_{2GN} \leq 10639 \text{ Nm}$

GFL14-2A				195C17	195C23	195C35	21XC17	21XC35
				...F10	...S00	...F10	...F10	...F10
i	M_{2GN}	J_G	M_1					
			n_1	1700	2340	3510	1710	3520
			I_{M400}	13.9	8.2	28.7	22.5	42.5
			P_N	6.4	4	13.2	11	20.3
			J_M	72.12	72.12	72.04	180.04	180.04
19.948	7873	111	M_2					1014
			c				5.6	
			n_2 Eck				177	
			n_2 th				101	
22.476	8870	105	M_2					1143
			c				5.6	
			n_2 Eck				157	
			n_2 th				90	
24.456	8282	83.2	M_2				1387	1245
			c				5.7	5.4
			n_2 Eck				70	144
			n_2 th				70	82
27.556	9331	79.4	M_2				1562	1403
			c				5.7	5.4
			n_2 Eck				62	128
			n_2 th				62	73
32.344	6387	52.9	M_2	1085		1085		
			c	5.6		4.8		
			n_2 Eck	53		109		
			n_2 th	53		76		
32.344	8734	52.9	M_2				1857	1667
			c				4.5	4.3
			n_2 Eck				53	109
			n_2 th				53	62
36.444	7196	50.7	M_2	1223		1223		
			c	5.6		4.8		
			n_2 Eck	47		96		
			n_2 th	47		67		
36.444	9841	50.7	M_2				2092	1878
			c				4.5	4.3
			n_2 Eck				47	97
			n_2 th				47	55
39.642	6916	38	M_2	1339		1338		
			c	5		4.3		
			n_2 Eck	43		89		
			n_2 th	43		62		
39.642	9101	38	M_2				2292	2057
			c				3.9	3.7
			n_2 Eck				43	89
			n_2 th				43	51
44.667	7793	36.6	M_2	1509		1507		
			c	5		4.3		
			n_2 Eck	38		79		
			n_2 th	38		55		
44.667	10254	36.6	M_2				2583	2318
			c				3.9	3.7
			n_2 Eck				38	79
			n_2 th				38	45
52.067	7136	24.6	M_2	1779		1774		
			c	3.9		3.4		
			n_2 Eck	33		67		
			n_2 th	33		47		

$M \dots$ [Nm]
 $n \dots$ [min^{-1}]
 $J \dots$ [kgcm^2]

$P \dots$ [kW]
 $I \dots$ [A]
 $i \dots$ [-]
 $c \dots$ [-]

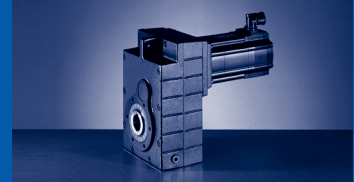

$M_{2GN} \leq 10639 \text{ Nm}$

GFL14-2A				195C17	195C23	195C35	21XC17	21XC35
				...F10	...S00	...F10	...F10	...F10
i	M_{2GN}	J_G	M_1					
			n_1	1700	2340	3510	1710	3520
			I_{M400}	13.9	8.2	28.7	22.5	42.5
			P_N	6.4	4	13.2	11	20.3
			J_M	72.12	72.12	72.04	180.04	180.04
52.067	9389	24.6	M_2				3037	2724
			c				3	2.9
			$n_{2 \text{ Eck}}$				33	68
			$n_{2 \text{ th}}$				33	39
58.667	8041	23.8	M_2	2005		1999		
			c	3.9		3.4		
			$n_{2 \text{ Eck}}$	29		60		
			$n_{2 \text{ th}}$	29		42		
58.667	10579	23.8	M_2				3422	3070
			c				3	2.9
			$n_{2 \text{ Eck}}$				29	60
			$n_{2 \text{ th}}$				29	34
63.19	7250	18	M_2	2174		2166		
			c	3.3		2.8		
			$n_{2 \text{ Eck}}$	27		56		
			$n_{2 \text{ th}}$	27		39		
63.19	9540	18	M_2				3705	3323
			c				2.5	2.4
			$n_{2 \text{ Eck}}$				27	56
			$n_{2 \text{ th}}$				27	32
71.2	8169	17.4	M_2	2449		2433		
			c	3.3		3.1		
			$n_{2 \text{ Eck}}$	24		49		
			$n_{2 \text{ th}}$	24		34		
71.2	10639	17.4	M_2				4176	3735
			c				2.5	2.7
			$n_{2 \text{ Eck}}$				24	49
			$n_{2 \text{ th}}$				24	28
79.875	7015	11.8	M_2	2770	1204	2750		
			c	2.5	5.6	2.4		
			$n_{2 \text{ Eck}}$	21	29	44		
			$n_{2 \text{ th}}$	21	29	31		
90	7905	11.5	M_2	3121	1357	3099		
			c	2.5	5.6	2.4		
			$n_{2 \text{ Eck}}$	19	26	39		
			$n_{2 \text{ th}}$	19	26	27		

$M \dots$ [Nm]
 $n \dots$ [min^{-1}]
 $J \dots$ [kgcm^2]

$P \dots$ [kW]
 $I \dots$ [A]
 $i \dots$ [-]
 $c \dots$ [-]

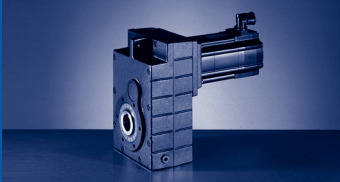

GFL [Nm]

GFL□□-□A (MCA)

$M_{2GN} \leq 11615 \text{ Nm}$

GFL14-3A				14LC16	14LC20	14LC35	14LC41	17NC17	17NC23	17NC35	17NC41
				...F10	...S00	...F10	...S00	...F10	...S00	...F10	...S00
i	M_{2GN}	J_G	M_1	12	6.7	10.8	5.4	21.5	10.8	19	9.5
			n_1	1635	2000	3455	4100	1680	2300	3480	4110
			I_{M400}	4.8	3.3	9.1	5.8	8.5	5.5	15.8	10.2
			P_N	2.1	1.4	3.9	2.3	3.8	2.6	6.9	4.1
			J_M	19.32	19.24	19.24	19.24	36.04	36.04	36.04	36.04
64.296	5610	26.32	M_2					1276		1129	
			c				4.3		4.1		
			$n_{2 \text{ Eck}}$				26		54		
			$n_{2 \text{ th}}$				26		48		
68.708	5416	19.86	M_2					1370		1207	
			c				3.8		4.1		
			$n_{2 \text{ Eck}}$				25		51		
			$n_{2 \text{ th}}$				24		45		
77.418	6103	19.38	M_2					1543		1360	
			c				3.8		4.1		
			$n_{2 \text{ Eck}}$				22		45		
			$n_{2 \text{ th}}$				22		40		
85.037	6276	21.59	M_2					1700		1498	
			c				3.6		3.9		
			$n_{2 \text{ Eck}}$				20		41		
			$n_{2 \text{ th}}$				20		36		
104.889	5375	9.32	M_2	1159		1040					
			c	4.5		4.7					
			$n_{2 \text{ Eck}}$	16		33					
			$n_{2 \text{ th}}$	16		33					
104.889	6292	9.32	M_2					2112	1028	1862	903
			c					2.9	5.8	3.1	6
			$n_{2 \text{ Eck}}$					16	22	33	39
			$n_{2 \text{ th}}$					16	22	30	30
104.889	6888	9.32	M_2								
			c								
			$n_{2 \text{ Eck}}$								
			$n_{2 \text{ th}}$								
114.126	5848	8.32	M_2	1261		1132					
			c	4.5		4.7					
			$n_{2 \text{ Eck}}$	14		30					
			$n_{2 \text{ th}}$	14		30					
114.126	6719	8.32	M_2					2299	1120	2027	984
			c					2.9	5.7	3.1	5.8
			$n_{2 \text{ Eck}}$					15	20	31	36
			$n_{2 \text{ th}}$					15	20	27	27
128.593	6589	8.14	M_2	1421		1275					
			c	4.5		4.7					
			$n_{2 \text{ Eck}}$	13		27					
			$n_{2 \text{ th}}$	13		27					
128.593	7571	8.14	M_2					2591	1262	2284	1108
			c					2.9	5.7	3.1	5.8
			$n_{2 \text{ Eck}}$					13	18	27	32
			$n_{2 \text{ th}}$					13	18	24	24
136.889	7359	16.78	M_2					2765	1351	2438	1186
			c					2.6	5.2	2.8	5.3
			$n_{2 \text{ Eck}}$					12	17	25	30
			$n_{2 \text{ th}}$					12	17	21	23
156.148	6830	5.92	M_2	1738		1560					
			c	3.8		4					
			$n_{2 \text{ Eck}}$	11		22					
			$n_{2 \text{ th}}$	10		22					

$M \dots$ [Nm]
 $n \dots$ [min^{-1}]
 $J \dots$ [kgcm^2]

$P \dots$ [kW]
 $I \dots$ [A]
 i [-]
 c [-]

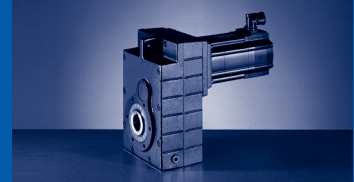

$M_{2GN} \leq 11615 \text{ Nm}$

								GFL14-3A			
195C17	195C23	195C35	195C42	21XC17	21XC25	21XC35	21XC42				
...F10	...S00	...F10	...S00	...F10	...S00	...F10	...S00				
36.3	16.3	36	12	61.4	24.6	55	17	M_1	J_G	M_{2GN}	i
1700	2340	3510	4150	1710	2490	3520	4160	n_1			
13.9	8.2	28.7	14	22.5	13.5	42.5	19.8	I_{M400}			
6.4	4	13.2	5.2	11	6.4	20.3	7.4	P_N			
72.12	72.12	72.04	72.12	180.04	180.04	180.04	180.04	J_M			
2195	955	2185		3754	1471	3365	1008	M_2			
2.5	5.5	2.2		1.5	3.6	1.4	4.3	c	26.32	5610	64.296
26	36	55		27	39	55	65	n_{2Eck}			
26	36	38		27	31	31	31	n_{2th}			
2352	1025	2335		4017	1576	3596	1077	M_2			
2.3	5.1	2.2		1.3	3.4	1.4	4.4	c	19.86	5416	68.708
25	34	51		25	36	51	61	n_{2Eck}			
25	34	36		25	29	29	29	n_{2th}			
2650	1155	2631		4526	1775	4051	1214	M_2			
2.3	5.1	2.2		1.3	3.4	1.4	4.4	c	19.38	6103	77.418
22	30	45		22	32	46	54	n_{2Eck}			
22	30	32		22	26	26	26	n_{2th}			
2915	1273	2894	926	4976	1954	4454	1337	M_2			
2.1	4.7	2	5.8	1.3	3.1	1.3	4.1	c	21.59	6276	85.037
20	28	41	49	20	29	41	49	n_{2Eck}			
20	28	29	29	20	24	24	24	n_{2th}			
								M_2			
								c	9.32	5375	104.889
								n_{2Eck}			
								n_{2th}			
								M_2			
								c	9.32	6292	104.889
								n_{2Eck}			
								n_{2th}			
3605	1579	3578	1151					M_2			
1.9	4.2	1.8	5.1					c	9.32	6888	104.889
16	22	34	40					n_{2Eck}			
16	22	23	23					n_{2th}			
								M_2			
								c	8.32	5848	114.126
								n_{2Eck}			
								n_{2th}			
3930	1726	3901	1259					M_2			
1.7	3.8	1.6	4.6					c	8.32	6719	114.126
15	21	31	36					n_{2Eck}			
15	21	21	21					n_{2th}			
								M_2			
								c	8.14	6589	128.593
								n_{2Eck}			
								n_{2th}			
4428	1945	4395	1419					M_2			
1.7	3.8	1.6	4.6					c	8.14	7571	128.593
13	18	27	32					n_{2Eck}			
13	18	19	19					n_{2th}			
4721	2078	4686	1517		3175		2178	M_2			
1.6	3.5	1.5	4.2		2.3		3	c	16.78	7359	136.889
12	17	26	30		18		30	n_{2Eck}			
12	17	16	18		15		15	n_{2th}			
								M_2			
								c	5.92	6830	156.148
								n_{2Eck}			
								n_{2th}			

M ... [Nm]
n ... [min⁻¹]
J ... [kgcm²]

P ... [kW]
I ... [A]
i [-]
c [-]

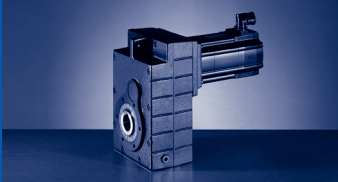

GFL [Nm]

GFL□□-□A (MCA)

$M_{2GN} \leq 11615 \text{ Nm}$

GFL14-3A				14LC16	14LC20	14LC35	14LC41	17NC17	17NC23	17NC35	17NC41
				...F10	...S00	...F10	...S00	...F10	...S00	...F10	...S00
i	M_{2GN}	J_G	M_1	12	6.7	10.8	5.4	21.5	10.8	19	9.5
			n_1	1635	2000	3455	4100	1680	2300	3480	4110
			I_{M400}	4.8	3.3	9.1	5.8	8.5	5.5	15.8	10.2
			P_N	2.1	1.4	3.9	2.3	3.8	2.6	6.9	4.1
			J_M	19.32	19.24	19.24	19.24	36.04	36.04	36.04	36.04
156.148	7992	5.92	M_2					3158	1545	2785	1357
			c					2.5	5	2.7	5.1
			$n_{2 \text{ Eck}}$					11	15	22	26
			$n_{2 \text{ th}}$					11	15	20	20
156.148	8227	5.92	M_2								
			c								
			$n_{2 \text{ Eck}}$								
			$n_{2 \text{ th}}$								
170.074	8408	6.96	M_2	1883		1690		3443	1686	3037	1481
			c	4.3		4.6		2.4	4.8	2.6	4.9
			$n_{2 \text{ Eck}}$	10		20		10	14	21	24
			$n_{2 \text{ th}}$	10		20		10	14	18	18
202.074	7076	3.69	M_2	2268	1233	2037					
			c	3.1	5.5	3.2					
			$n_{2 \text{ Eck}}$	8	10	17					
			$n_{2 \text{ th}}$	8	10	17					
202.074	8281	3.69	M_2					4109	2021	3625	1776
			c					2	4	2.2	4.1
			$n_{2 \text{ Eck}}$					8	11	17	20
			$n_{2 \text{ th}}$					8	11	15	15
224.636	8739	4.74	M_2	2512		2256		4572	2251	4035	1978
			c	3.4		3.6		1.9	3.8	2	3.9
			$n_{2 \text{ Eck}}$	7		15		8	10	16	18
			$n_{2 \text{ th}}$	7		15		7	10	14	14
253.111	9846	4.7	M_2	2830		2541		5152	2537	4546	2229
			c	3.4		3.6		1.9	3.8	2	3.9
			$n_{2 \text{ Eck}}$	7		14		7	9	14	16
			$n_{2 \text{ th}}$	6		14		7	9	12	12
273.778	9753	5.76	M_2	3071	1669	2758		5582	2753	4926	2420
			c	3.1	5.6	3.3		1.7	3.5	1.9	3.5
			$n_{2 \text{ Eck}}$	6	7	13		6	8	13	15
			$n_{2 \text{ th}}$	6	7	13		6	8	11	11
332.444	10550	4.3	M_2	3742	2041	3362	1634	6792	3357	5995	2950
			c	2.8	5	2.9	5.5	1.5	3.1	1.7	3.2
			$n_{2 \text{ Eck}}$	5	6	10	12	5	7	11	12
			$n_{2 \text{ th}}$	5	6	10	11	5	7	9	9
352.811	10343	2.16	M_2	3980	2174	3576	1742				
			c	2.6	4.6	2.7	5.1				
			$n_{2 \text{ Eck}}$	5	6	10	12				
			$n_{2 \text{ th}}$	5	6	10	10				
352.811	10389	2.16	M_2					7216	3571	6370	3139
			c					1.4	2.9	1.5	2.9
			$n_{2 \text{ Eck}}$					5	7	10	12
			$n_{2 \text{ th}}$					5	7	9	9
397.533	11615	2.15	M_2	4485	2451	4030	1963	8132	4024	7178	3537
			c	2.6	4.6	2.7	5.1	1.4	2.8	1.5	2.9
			$n_{2 \text{ Eck}}$	4	5	9	10	4	6	9	10
			$n_{2 \text{ th}}$	4	5	9	9	4	6	8	8
430.222	10560	2.73	M_2	4875	2673	4381	2144	8822	4376	7788	3847
			c	2.1	3.8	2.3	4.3	1.2	2.4	1.3	2.4
			$n_{2 \text{ Eck}}$	4	5	8	10	4	5	8	10
			$n_{2 \text{ th}}$	4	5	8	8	4	5	7	7

$M \dots$ [Nm]
 $n \dots$ [min^{-1}]
 $J \dots$ [kgcm^2]

$P \dots$ [kW]
 $I \dots$ [A]
 $i [-]$
 $c [-]$

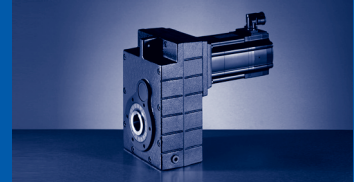

$M_{2GN} \leq 11615 \text{ Nm}$

195C17	195C23	195C35	195C42	21XC17	21XC25	21XC35	21XC42	GFL14-3A			
...F10	...S00	...F10	...S00	...F10	...S00	...F10	...S00	M_1	J_G	M_{2GN}	i
36.3	16.3	36	12	61.4	24.6	55	17	n_1			
1700	2340	3510	4150	1710	2490	3520	4160	I_{M400}			
13.9	8.2	28.7	14	22.5	13.5	42.5	19.8	P_N			
6.4	4	13.2	5.2	11	6.4	20.3	7.4	J_M			
72.12	72.12	72.04	72.12	180.04	180.04	180.04	180.04	M_2 c			
								n_2 Eck	5.92	7992	156.148
								n_2 th			
5388	2372	5347	1732					M_2 c			
1.5	3.4	1.5	4.1					n_2 Eck	5.92	8227	156.148
11	15	23	27					n_2 th			
11	15	16	16					M_2 c			
5874	2589	5829	1892					n_2 Eck	6.96	8408	170.074
1.4	3.2	1.4	3.9					n_2 th			
10	14	21	24					M_2 c			
10	14	14	14					n_2 Eck	3.69	7076	202.074
								n_2 th			
								M_2 c			
								n_2 Eck	3.69	8281	202.074
								n_2 th			
7783	3444	7723	2521					M_2 c			
1.1	2.5	1.1	3					n_2 Eck	4.74	8739	224.636
8	10	16	19					n_2 th			
8	10	11	11					M_2 c			
8769	3881	8701	2841					n_2 Eck	4.7	9846	253.111
1.1	2.5	1.1	3					n_2 th			
7	9	14	16					M_2 c			
7	9	10	10					n_2 Eck	5.76	9753	273.778
9495	4207		3081					n_2 th			
1	2.3		2.8					M_2 c			
6	9		15					n_2 Eck	4.3	10550	332.444
6	9		9					n_2 th			
	5122		3753					M_2 c			
	2		2.5					n_2 Eck	2.16	10343	352.811
	7		13					n_2 th			
	7		7					M_2 c			
								n_2 Eck	2.16	10389	352.811
								n_2 th			
								M_2 c			
								n_2 Eck	2.15	11615	397.533
								n_2 th			
								M_2 c			
								n_2 Eck	2.73	10560	430.222
								n_2 th			

$M \dots$ [Nm]
 $n \dots$ [min^{-1}]
 $J \dots$ [kgcm^2]

$P \dots$ [kW]
 $I \dots$ [A]
 $i [-]$
 $c [-]$

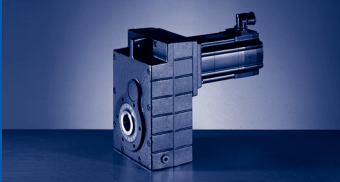

GFL [Nm]

GFL□□-□A (MCA)

$M_{2GN} \leq 11615 \text{ Nm}$

GFL14-3A				14LC16	14LC20	14LC35	14LC41	17NC17	17NC23	17NC35	17NC41
				...F10	...S00	...F10	...S00	...F10	...S00	...F10	...S00
i	M_{2GN}	J_G	M_1	12	6.7	10.8	5.4	21.5	10.8	19	9.5
			n_1	1635	2000	3455	4100	1680	2300	3480	4110
			I_{M400}	4.8	3.3	9.1	5.8	8.5	5.5	15.8	10.2
			P_N	2.1	1.4	3.9	2.3	3.8	2.6	6.9	4.1
			J_M	19.32	19.24	19.24	19.24	36.04	36.04	36.04	36.04
522.133	10560	1.98	M_2	5940	3268	5340	2623		5335	9475	4690
			c	1.8	3.2	1.9	3.5		2	1.1	2
			$n_{2 \text{ Eck}}$	3	4	7	8		4	7	8
			$n_{2 \text{ th}}$	3	4	7	7		4	6	6
562.391	9036	1.91	M_2	6422	3544	5775	2847		5771		5074
			c	1.4	2.5	1.5	2.8		1.6		1.6
			$n_{2 \text{ Eck}}$	3	4	6	7		4		7
			$n_{2 \text{ th}}$	3	4	6	6		4		6
633.68	9811	1.9	M_2	7240	3997	6511	3212		6506		5721
			c	1.4	2.4	1.4	2.7		1.5		1.5
			$n_{2 \text{ Eck}}$	3	3	6	7		4		7
			$n_{2 \text{ th}}$	3	3	5	6		4		5
710.888	9036	1.26	M_2	8143	4505	7324	3622				
			c	1.1	2	1.2	2.2				
			$n_{2 \text{ Eck}}$	2	3	5	6				
			$n_{2 \text{ th}}$	2	3	5	5				
801	9811	1.25	M_2	9179	5080	8256	4084				
			c	1.1	1.9	1.1	2.1				
			$n_{2 \text{ Eck}}$	2	3	4	5				
			$n_{2 \text{ th}}$	2	3	4	4				

M ... [Nm]
 n ... [min⁻¹]
 J ... [kgcm²]

P ... [kW]
 I ... [A]
 i [-]
 c [-]

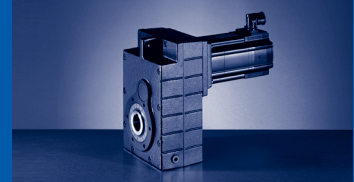

$M_{2GN} \leq 11615 \text{ Nm}$

195C17	195C23	195C35	195C42	21XC17	21XC25	21XC35	21XC42	GFL14-3A			
...F10	...S00	...F10	...S00	...F10	...S00	...F10	...S00	M_1	J_G	M_{2GN}	i
36.3	16.3	36	12	61.4	24.6	55	17	n_1			
1700	2340	3510	4150	1710	2490	3520	4160	I_{M400}			
13.9	8.2	28.7	14	22.5	13.5	42.5	19.8	P_N			
6.4	4	13.2	5.2	11	6.4	20.3	7.4	J_M			
72.12	72.12	72.04	72.12	180.04	180.04	180.04	180.04	M_2 c n_{2Eck} n_{2th}	1.98	10560	522.133
								M_2 c n_{2Eck} n_{2th}	1.91	9036	562.391
								M_2 c n_{2Eck} n_{2th}	1.9	9811	633.68
								M_2 c n_{2Eck} n_{2th}	1.26	9036	710.888
								M_2 c n_{2Eck} n_{2th}	1.25	9811	801

M ... [Nm]
n ... [min⁻¹]
J ... [kgcm²]

P ... [kW]
I ... [A]
i [-]
c [-]

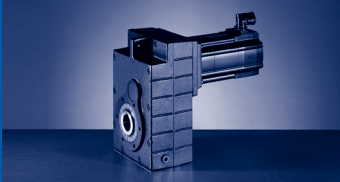

GFL [mm]

GFL□□-2S (MCS)

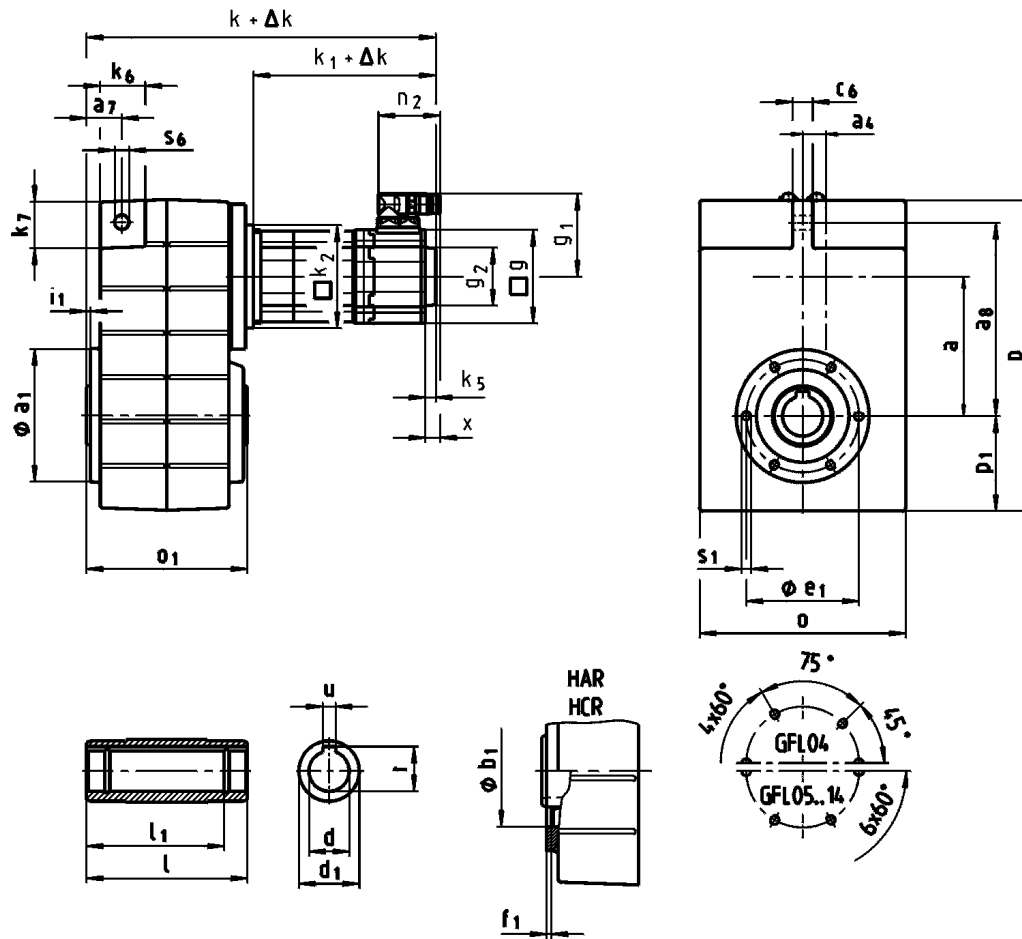

GFL□□-2S H□R ... RSO

		06C C41	06F C41	06I C41	09D C41	09F C38	09H C41	09L C41	12D C20	12D C41	12H C15	12H C30	12H C35	12L C20	12L C41		
GFL04...	k	260	290	320	312	332	352	392									
GFL05...	k	281	311	341	334	354	374	414	351		391			431			
GFL06...	k	294	324	354	347	367	387	427	364		404			444			
GFL07...	k				380	400	420	460	397		437			477			
GFL09...	k								431		471			511			
...RSO B0 ¹⁾	Δk	0															
...RSO P□ ¹⁾	Δk	19									20						
...RSO	k_1	132	162	192	183	203	223	263	188		228			268			
	k_2	66			91						118			145 ²⁾			
	g	62			89						116						
	k_5	0			13						14						
	g_2	□ 62			Ø 67						Ø 72						
	g_1	76			90						105						
	n_2	64			78												
	x	21						18									

¹⁾ → 801 - SRS / SRM / ECN / EQN / EQI / C20

²⁾ GFL05: 12DC20 ... 12LC41

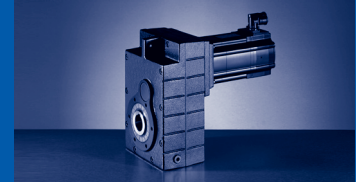

GFL□□-2S H□R ... RSO

		14D C15	14D C36	14H C15	14H C32	14L C15	14L C32	14P C14	14P C32	19F C14	19F C30	19J C14	19J C30	19P C14	19P C30	
GFL06...	k	379		419		459		499								
GFL07...	k	412		452		492		532		451		491		551		
GFL09...	k	446		486		526		566		485		525		585		
GFL11...	k	487		527		567		607		526		566		626		
GFL14...	k									571		611		671		
...RSO B0 ¹⁾	Δ k	0														
...RSO P□ ¹⁾	Δ k	28									34		44			
	k ₁	201		241		281		321		220		260		320		
	k ₂	145						195								
	g	143						192								
...RSO	k ₅	24						15								
	g ₂	Ø 78														
	g ₁	116				147		116	147	141	172	141	172	141	172	
	n ₂	78				94		78	94	78	94	78	94	78	94	
	x	16				38		16	38	16	36	16	36	16	36	

¹⁾ → 801 - SRS / SRM / ECN / EQN / EQI / C20

GFL□□-2S H□R

	o	o ₁	p	p ₁	a	a ₄	a ₇	a ₈	c ₆	s ₆	k ₆	k ₇
GFL04...	148	115	214	69	90.5	12.5	22.5	128	14	12.5	32	35
GFL05...	165	140	252	78	112.5	18.5	29	155	16	14	35	38
GFL06...	206	160	315	98	140	22	35	195	20		46	46
GFL07...	256	200	386	118	173	29	44	240	25	18	56	56
GFL09...	318	240	486	149	220	37.5	50	300	32	22	70	70
GFL11...	395	290	600	181	276.5	50	65	375	40	26	84	90
GFL14...	490	350	740	228	339	65	80	455	50	32	100	114

	d	l	d ₁	l ₁	u	t	a ₁	b ₁	e ₁	f ₁	i ₁	s ₁
	H7				JS9	+0,2		H7				
GFL04...	25	115	45	100	8	28.3	110	75	90	3	2.5	M6x12
	30					33.3						
GFL05...	35	140	50	124	10	38.3	118	80	100	4	4	M8x15
GFL06...	40	160	65	140	12	43.3	140	100	120			
	45				14	48.8						
GFL07...	50	200	75	175	14	53.8	165	115	140	5	5	M12x18
	55				16	59.3						
GFL09...	60	240	95	210	18	64.4	205	145	175	6	6	M16x24
	70				20	74.9						
GFL11...	80	290	105	250	22	85.4	240	140	205	6	6	M20x32
GFL14...	100				28	106.4						

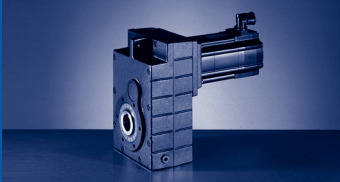

GFL [mm]

GFL□□-2S (MCS)

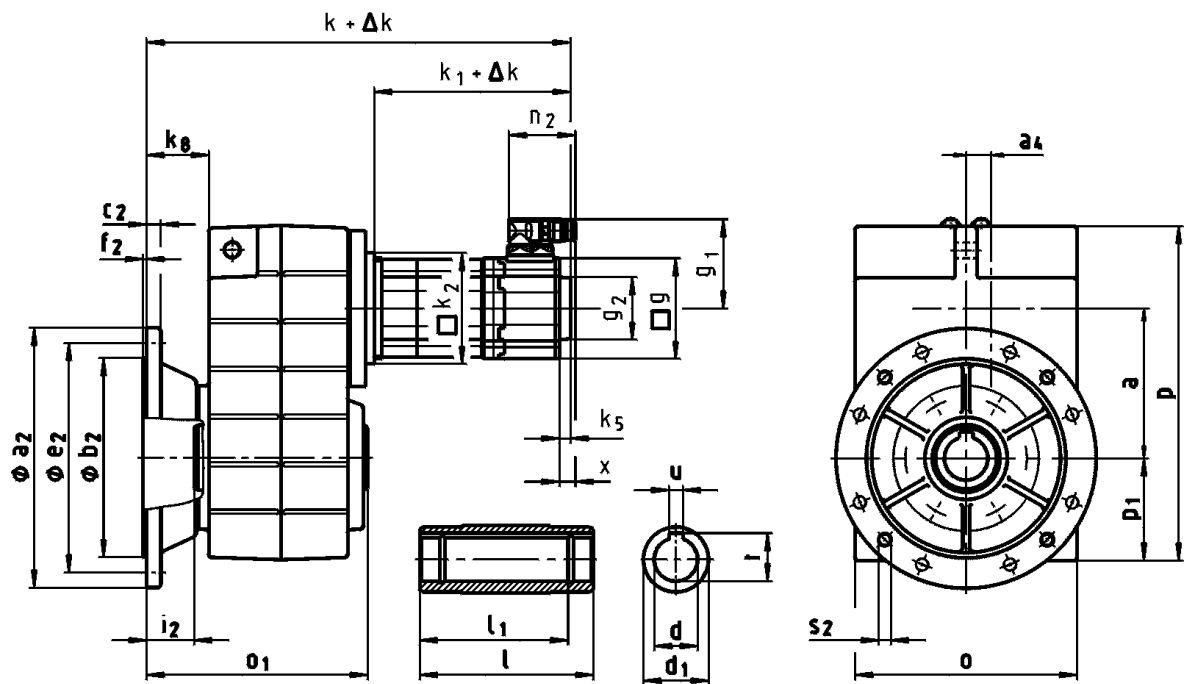

GFL□□-2S HCK ... RSO

		06C C41	06F C41	06I C41	09D C41	09F C38	09H C41	09L C41	12D C20	12D C41	12H C15	12H C30	12H C35	12L C20	12L C41
GFL04...	k	293	323	353	346	366	386	426							
GFL05...	k	315	345	375	367	387	407	447	384		424			464	
GFL06...	k	337	367	397	389	409	429	469	406		446			486	
GFL07...	k				435	455	475	515	452		492			532	
GFL09...	k								491		531			571	
...RSO B0 ¹⁾	Δk	0													
...RSO P□ ¹⁾	Δk	19				20									
...RSO	k_1	132	162	192	183	203	223	263	188		228			268	
	k_2	66			91								118	145 ²⁾	
	g	62			89								116		
	k_5	0			13								14		
	g_2	□ 62			Ø 67								Ø 72		
	g_1	76			90								105		
	n_2	64							78						
x	21							18							

¹⁾ → 801 - SRS / SRM / ECN / EQN / EQI / C20

²⁾ GFL05: 12DC20 ... 12LC41

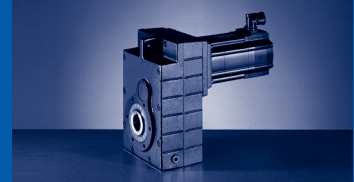

GFL□□-2S HCK ... RSO

		14D C15	14D C36	14H C15	14H C32	14L C15	14L C32	14P C14	14P C32	19F C14	19F C30	19J C14	19J C30	19P C14	19P C30	
GFL06...	k	422		462		502		542								
GFL07...	k	468		508		548		588		507		547		607		
GFL09...	k	507		547		587		627		546		586		646		
GFL11...	k	548		588		628		668		587		627		687		
GFL14...	k									632		672		732		
...RSO B0 ¹⁾	Δ k	0														
...RSO P□ ¹⁾	Δ k	28						34			44					
	k ₁	201		241		281		321		220		260		320		
	k ₂	145						195								
	g	143						192								
...RSO	k ₅	24						15								
	g ₂	Ø 78														
	g ₁	116				147	116	147	141	172	141	172	141	172	141	172
	n ₂	78				94	78	94	78	94	78	94	78	94	78	94
	x	16				38	16	38	16	36	16	36	16	36	16	36

¹⁾ → 801 - SRS / SRM / ECN / EQN / EQI / C20

GFL□□-2S HCK

	o	o ₁	p	p ₁	a	a ₄	k _g
GFL04...	148	148	214	69	90.5	12.5	42
GFL05...	165	173	252	78	112.5	18.5	46
GFL06...	206	201	315	98	140	22	56
GFL07...	256	255	386	118	173	29	73
GFL09...	318	300	486	149	220	37.5	78
GFL11...	395	350	600	181	276.5	50	86
GFL14...	490	410	740	228	339	65	90

	d	l	d ₁	l ₁	u	t	a ₂	b ₂	c ₂	e ₂	f ₂	i ₂	s ₂
	H7				JS9	+0,2		j7					
GFL04...	25	115	45	100	8	28.3	160	110	10	130	3.5	33.5	4 x 9
GFL05...	30					33.3							
	35	140	50	124	10	38.3	200	130	12	165	4	42.5	4 x 11
GFL06...	40					43.3							
	45	160	65	140	14	48.8	250	180	15	215	4	41.5	4 x 14
GFL07...	50					53.8							
	55	200	75	175	16	59.3	300	230	17	265	4	55.5	4 x 17.5
GFL09...	60					64.4							
	70	240	95	210	20	74.9	350	250	18	300	5	60.5	4 x 17.5
GFL11...	80					85.4							
GFL14...	100	350	135	305	28	106.4	450	350	22	400	5	8 x 17.5	

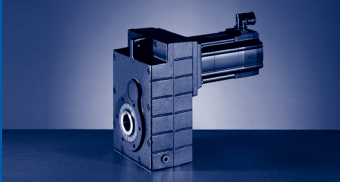

GFL [mm]

GFL□□-2S (MCS)

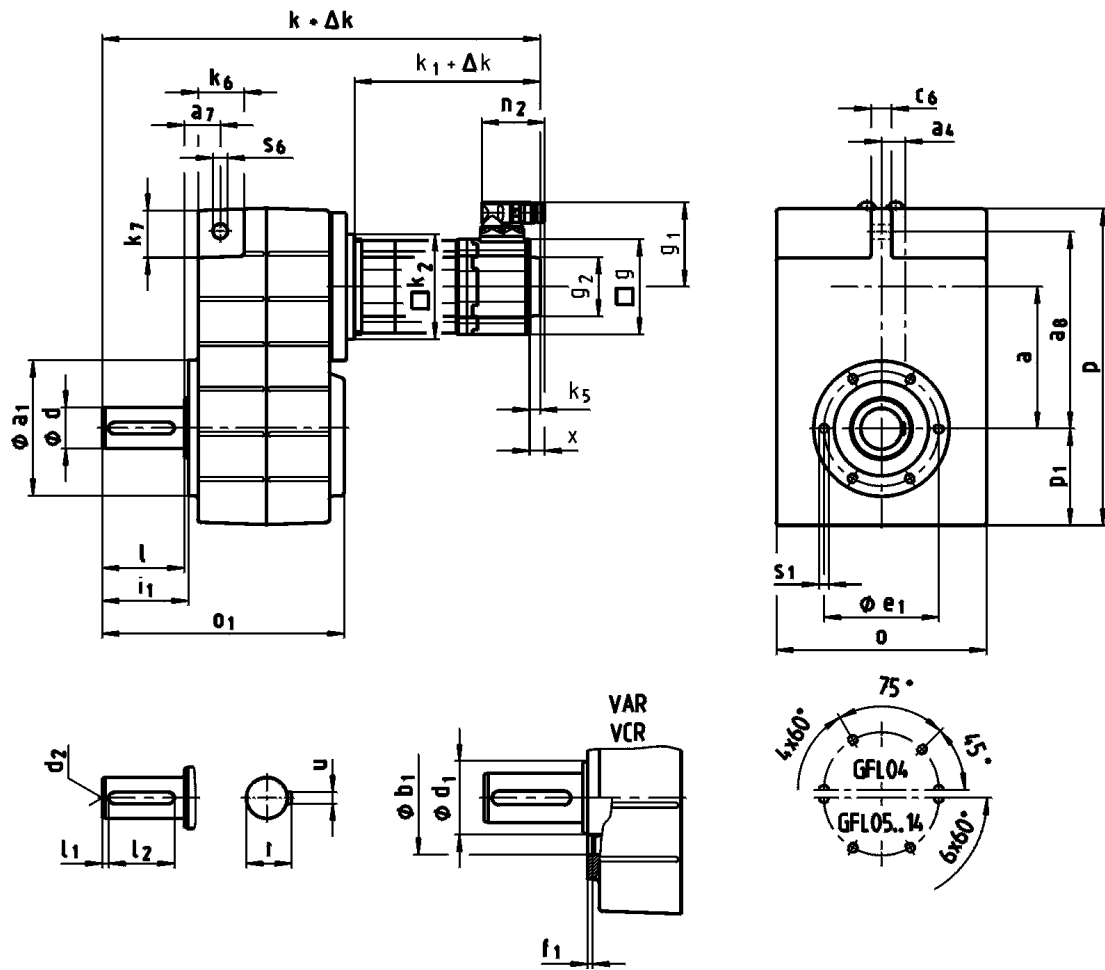

GFL□□-2S V□R ... RSO

		06C C41	06F C41	06I C41	09D C41	09F C38	09H C41	09L C41	12D C20	12D C41	12H C15	12H C30	12H C35	12L C20	12L C41		
GFL04...	k	310	340	370	362	382	402	442									
GFL05...	k	341	371	401	394	414	434	474	411			451			491		
GFL06...	k	374	404	434	427	447	467	507	444			484			524		
GFL07...	k				480	500	520	560	497			537			577		
GFL09...	k								551			591			631		
...RSO B0 ¹⁾	Δk	0															
...RSO P□ ¹⁾	Δk	19								20							
...RSO	k_1	132	162	192	183	203	223	263	188			228			268		
	k_2	66			91								118 145 ²⁾				
	g	62			89								116				
	k_5	0			13								14				
	g_2	□ 62			Ø 67								Ø 72				
	g_1	76			90								105				
	n_2	64							78								
	x				21								18				

¹⁾ → 801 - SRS / SRM / ECN / EQN / EQI / C20

²⁾ GFL05: 12DC20 ... 12LC41

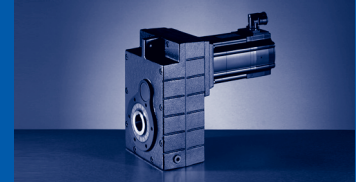

GFL□□-2S V□R ... RSO

		14D C15	14D C36	14H C15	14H C32	14L C15	14L C32	14P C14	14P C32	19F C14	19F C30	19J C14	19J C30	19P C14	19P C30
GFL06...	k	459		499		539		579							
GFL07...	k	512		552		592		632		551		591		651	
GFL09...	k	566		606		646		686		605		645		705	
GFL11...	k	647		687		727		767		686		726		786	
GFL14...	k									771		811		871	
...RSO B0 ¹⁾	Δ k	0													
...RSO P□ ¹⁾	Δ k	28						34			44				
	k ₁	201		241		281		321		220		260		320	
	k ₂	145						195							
	g	143						192							
...RSO	k ₅	24						15							
	g ₂	Ø 78													
	g ₁	116				147		116	147	141	172	141	172	141	172
	n ₂	78				94		78	94	78	94	78	94	78	94
	x	16				38		16	38	16	36	16	36	16	36

¹⁾ → 801 - SRS / SRM / ECN / EQN / EQI / C20

GFL□□-2S V□R

	o	o ₁	p	p ₁	a	a ₄	a ₇	a ₈	c ₆	s ₆	k ₆	k ₇
GFL04...	148	163	214	69	90.5	12.5	22.5	128	14	12.5	32	35
GFL05...	165	197	252	78	112.5	18.5	29	155	16	14	35	38
GFL06...	206	236	315	98	140	22	35	195	20		46	46
GFL07...	256	296	386	118	173	29	44	240	25	18	56	56
GFL09...	318	356	486	149	220	37.5	50	300	32	22	70	70
GFL11...	395	445	600	181	276.5	50	65	375	40	26	84	90
GFL14...	490	544	740	228	339	65	80	455	50	32	100	114

	d	l	d ₁	l ₁	l ₂	d ₂	u	t	a ₁	b ₁	e ₁	f ₁	i ₁	s ₁
										H7				
GFL04...	25	50	45	4	40	M10	8	28	110	75	90	3	52.5	M6x12
GFL05...	30	60	50	6	45			33	118	80	100		4	64
GFL06...	40	80	65	7	63	M16	12	43	140	100	120	5		85
GFL07...	50	100	75	8	80			14	53.5	165	115		140	175
GFL09...	60	120	95		100	M20	18	64	205	145	175	6	125	M16x24
GFL11...	80	160	105	15	125		22	85	240	140	205		205	166
GFL14...	100	200	135	18	160	M24	28	106	290	170	250	207	M24x35	

d ≤ 50 mm: k6; d > 50 mm: m6

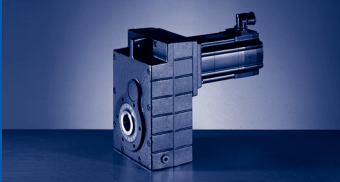

GFL [mm]

GFL□□-2S (MCS)

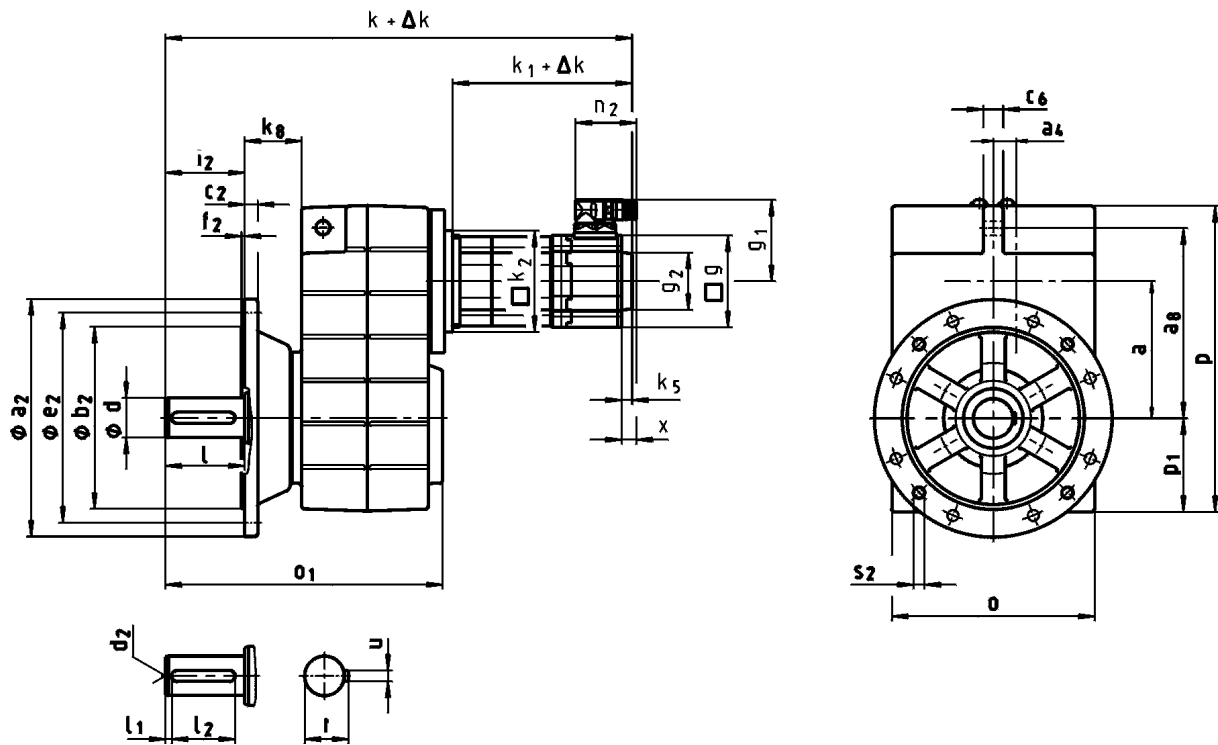

GFL□□-2S VCK ... RSO

		06C C41	06F C41	06I C41	09D C41	09F C38	09H C41	09L C41	12D C20	12D C41	12H C15	12H C30	12H C35	12L C20	12L C41		
GFL04...	k	343	373	403	396	416	436	476									
GFL05...	k	374	404	434	427	447	467	507	444		484			524			
GFL06...	k	415	445	475	468	488	508	548	485		525			565			
GFL07...	k				535	555	575	615	552		592			632			
GFL09...	k								611		651			691			
...RSO B0 ¹⁾	Δk	0															
...RSO P□ ¹⁾	Δk	19								20							
...RSO	k_1	132	162	192	183	203	223	263	188		228			268			
	k_2	66			91							118		145 ²⁾			
	g	62			89							116					
	k_5	0			13							14					
	g_2	□ 62			Ø 67							Ø 72					
	g_1	76			90							105					
	n_2	64							78								
	x	21											18				

¹⁾ → 801 - SRS / SRM / ECN / EQN / EQI / C20

²⁾ GFL05: 12DC20 ... 12LC41

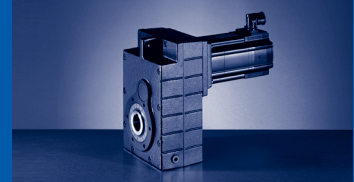

GFL□□-2S VCK ... RSO

		14D C15	14D C36	14H C15	14H C32	14L C15	14L C32	14P C14	14P C32	19F C14	19F C30	19J C14	19J C30	19P C14	19P C30				
GFL06...	k	500		540		580		620											
GFL07...	k	567		607		647		687		606		646		706					
GFL09...	k	626		666		706		746		665		705		765					
GFL11...	k	707		747		787		827		746		786		846					
GFL14...	k									831		871		931					
...RSO B0 ¹⁾	Δ k	0																	
...RSO P□ ¹⁾	Δ k	28						34			44								
	k ₁	201		241		281		321		220		260		320					
	k ₂	145						195											
	g	143						192											
...RSO	k ₅	24						15											
	g ₂	Ø 78																	
	g ₁	116				147		116		147		141		172		141		172	
	n ₂	78				94		78		94		78		94		78		94	
	x	16				38		16		38		16		36		16		36	

¹⁾ → 801 - SRS / SRM / ECN / EQN / EQI / C20

GFL□□-2S VCK

	o	o ₁	p	p ₁	a	a ₄	k _g
GFL04...	148	196	214	69	90.5	12.5	42
GFL05...	165	230	252	78	112.5	18.5	46
GFL06...	206	277	315	98	140	22	56
GFL07...	256	351	386	118	173	29	73
GFL09...	318	416	486	149	220	37.5	78
GFL11...	395	505	600	181	276.5	50	86
GFL14...	490	604	740	228	339	65	90

	d	l	l ₁	l ₂	d ₂	u	t	a ₂	b ₂	c ₂	e ₂	f ₂	i ₂	s ₂
									j7					
GFL04...	25	50	4	40	M10	8	28	160	110	10	130	3.5	50	4 x 9
GFL05...	30	60	6	45			33	200	130	12	165		60	4 x 11
GFL06...	40	80	7	63	M16	14	43	250	180	15	215	4	80	4 x 14
GFL07...	50	100	8	80			53.5	300	230	17	265		100	
GFL09...	60	120		100	M20	22	64	350	250	18	300	5	120	4 x 17.5
GFL11...	80	160	15	125			85	400	300	20	350		160	
GFL14...	100	200	18	160	M24	28	106	450	350	22	400		200	8 x 17.5

d ≤ 50 mm: k6; d > 50 mm: m6

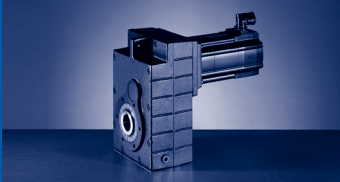

GFL [mm]

GFL□□-3S (MCS)

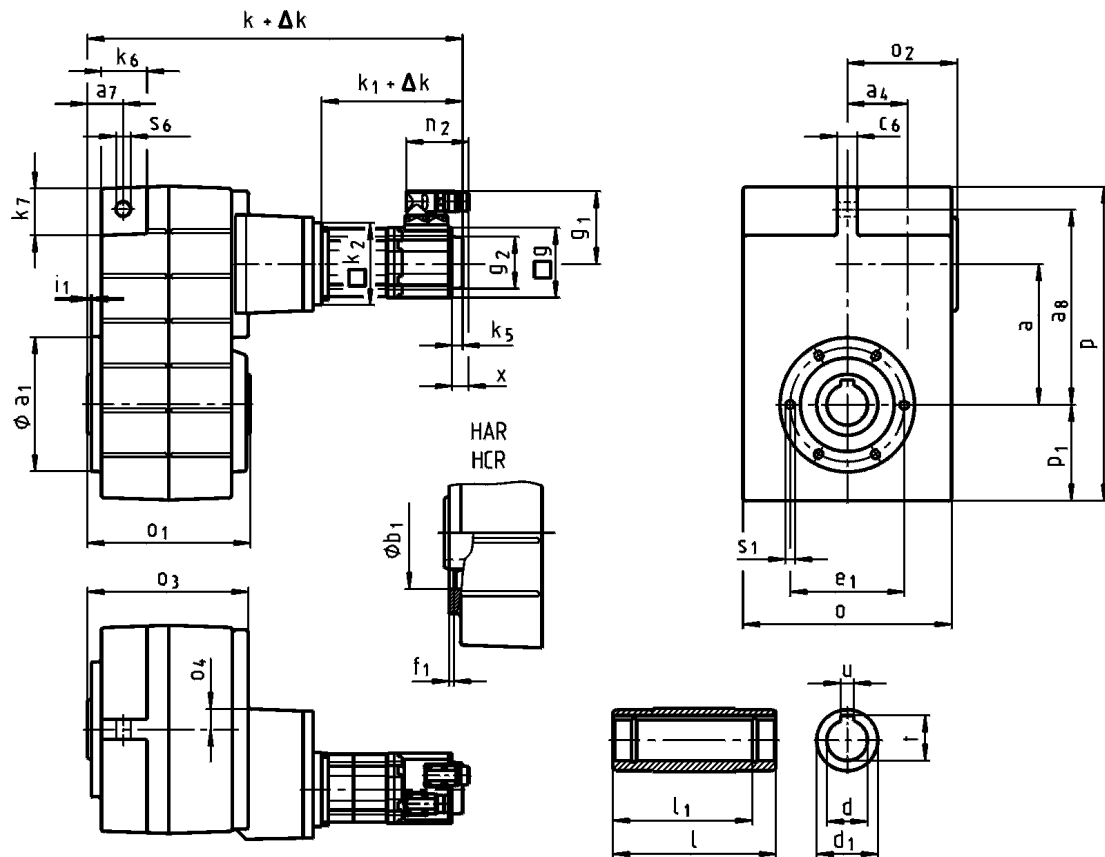

GFL□□-3S H□R ... RSO

		06C C41	06F C41	06I C41	09D C41	09F C38	09H C41	09L C41	12D C20	12D C41	12H C15	12H C30	12H C35	12L C20	12L C41	
GFL05...	k	358	388	418	410	430	450	490								
GFL06...	k	388	418	448	440	460	480	520								
GFL07...	k	432	462	492	484	504	524	564	501		541			581		
GFL09...	k	484	514	544	536	556	576	616	553		593			633		
GFL11...	k				596	616	636	676	613		653			693		
GFL14...	k								692		732			772		
...RSO B0 ¹⁾	Δk	0														
...RSO P□ ¹⁾	Δk	19			20											
	k_1	132	162	192	183	203	223	263	188		228			268		
	k_2	66			91							118				
	g	62			89							116				
...RSO	k_5	0			13							14				
	g_2	□ 62			Ø 67							Ø 72				
	g_1	76			90							105				
	n_2	64								78						
	x				21							18				

¹⁾ → 801 - SRS / SRM / ECN / EQN / EQI / C20

²⁾ GFL07: 12DC20 ... 12LC41

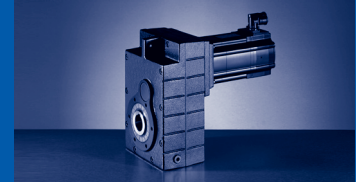

GFL□□-3S H□R ... RSO

		14D C15	14D C36	14H C15	14H C32	14L C15	14L C32	14P C14	14P C32	19F C14	19F C30	19J C14	19J C30	19P C14	19P C30	
GFL09...	k	569		609		649		689								
GFL11...	k	629		669		709		749		668		708		768		
GFL14...	k	708		748		788		828		747		787		847		
...RSO B0 ¹⁾	Δ k	0														
...RSO P□ ¹⁾	Δ k	28						34			44					
	k ₁	201		241		281		321		220		260		320		
	k ₂	145						195								
	g	143						192								
...RSO	k ₅	24						15								
	g ₂	Ø 78														
	g ₁	116				147	116	147	141	172	141	172	141	172	141	172
	n ₂	78				94	78	94	78	94	78	94	78	94	78	94
	x	16				38	16	38	16	36	16	36	16	36	16	36

1) → 801 - SRS / SRM / ECN / EQN / EQ / C20

GFL□□-3S H□R

	o	o ₁	o ₂	o ₃	o ₄	p	p ₁	a	a ₄	a ₇	a ₈	c ₆	s ₆	k ₆	k ₇
GFL05...	165	140	107	141	23	252	78	112.5	54.5	29	155	16	14	35	38
GFL06...	206	160	111	160	20	315	98	140	58	35	195	20		46	46
GFL07...	256	200	135	199	24	386	118	173	74	44	240	25	18	56	56
GFL09...	318	240	170	238	27	486	149	220	93.5	50	300	32	22	70	70
GFL11...	395	290	216	285	34	600	181	276.5	120	65	375	40	26	84	90
GFL14...	490	350	271	340	38	740	228	339	154	80	455	50	32	100	114

	d	l	d ₁	l ₁	u	t	a ₁	b ₁	e ₁	f ₁	i ₁	s ₁	
	H7				JS9	+0,2		H7				6x60°	
GFL05...	30	140	50	124	8	33.3	118	80	100	4	4	M8x15	
	35				10	38.3							
GFL06...	40	160	65	140	12	43.3	140	100	120		5	5	M10x16
	45				14	48.8							
GFL07...	50	200	75	175	14	53.8	165	115	140	6	6	M12x18	
	55				16	59.3							
GFL09...	60	240	95	210	18	64.4	205	145	175	7	7	M16x24	
	70				20	74.9							
GFL11...	80	290	105	250	22	85.4	240	140	205	8	8	M20x32	
	80				22	85.4							
GFL14...	100	350	135	305	28	106.4	290	170	250	9	9	M24x35	

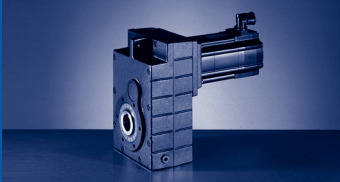

GFL [mm]

GFL□□-3S (MCS)

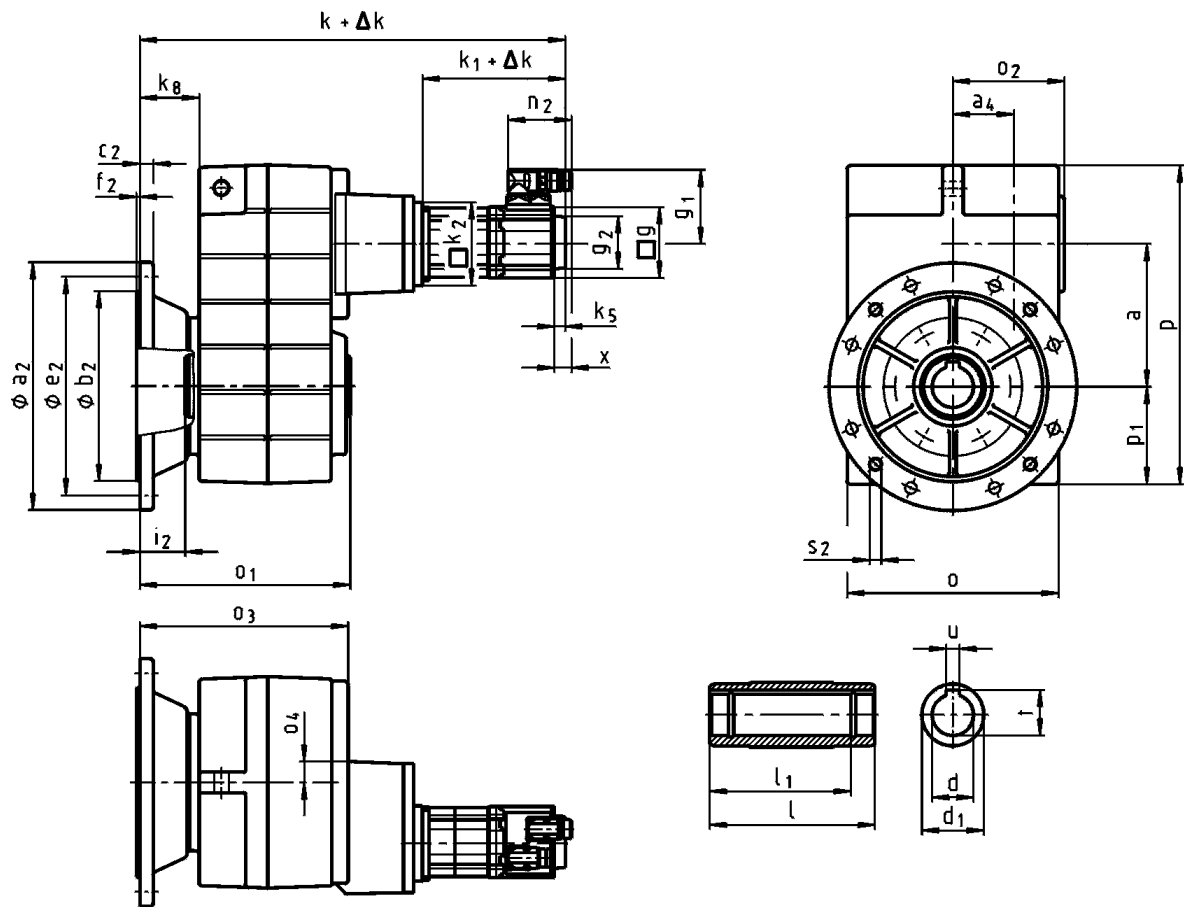

GFL□□-3S HCK ... RSO

		06C C41	06F C41	06I C41	09D C41	09F C38	09H C41	09L C41	12D C20	12D C41	12H C15	12H C30	12H C35	12L C20	12L C41	
GFL05...	k	391	421	451	444	464	484	524								
GFL06...	k	430	460	490	483	503	523	563								
GFL07...	k	487	517	547	540	560	580	620	557		597			637		
GFL09...	k	544	574	604	597	617	637	677	614		654			694		
GFL11...	k				657	677	697	737	674		714			754		
GFL14...	k								753		793			833		
...RSO B0 ¹⁾	Δk	0														
...RSO P□ ¹⁾	Δk	19				20										
...RSO	k_1	132	162	192	183	203	223	263	188		228			268		
	k_2	66			91				118				145 ²⁾			
	g	62			89				116							
	k_5	0			13				14							
	g_2	□ 62			Ø 67				Ø 72							
	g_1	76			90				105							
	n_2	64							78							
	x				21				18							

¹⁾ → 801 - SRS / SRM / ECN / EQN / EQ / C20

²⁾ GFL07: 12DC20 ... 12LC41

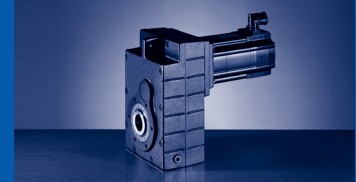

GFL□□-3S HCK ... RSO

		14D C15	14D C36	14H C15	14H C32	14L C15	14L C32	14P C14	14P C32	19F C14	19F C30	19J C14	19J C30	19P C14	19P C30	
GFL09...	k	629		669		709		749								
GFL11...	k	689		729		769		809		728		768		828		
GFL14...	k	768		808		848		888		807		847		907		
...RSO B0 ¹⁾	Δ k	0														
...RSO P□ ¹⁾	Δ k	28						34			44					
	k ₁	201		241		281		321		220		260		320		
	k ₂	145						195								
	g	143						192								
...RSO	k ₅	24						15								
	g ₂	Ø 78														
	g ₁	116				147	116	147	141	172	141	172	141	172	141	172
	n ₂	78				94	78	94	78	94	78	94	78	94	78	94
	x	16				38	16	38	16	36	16	36	16	36	16	36

1) → 801 - SRS / SRM / ECN / EQN / EQI / C20

GFL□□-3S HCK

	o	o ₁	o ₂	o ₃	o ₄	p	p ₁	a	a ₄	k ₈
GFL05...	165	173	107	174	23	252	78	112.5	54.5	46
GFL06...	206	201	111	201	20	315	98	140	58	56
GFL07...	256	255	135	254	24	386	118	173	74	73
GFL09...	318	300	170	298	27	486	149	220	93.5	78
GFL11...	395	350	216	345	34	600	181	276.5	120	86
GFL14...	490	410	271	400	38	740	228	339	154	90

	d	l	d ₁	l ₁	u	t	a ₂	b ₂	c ₂	e ₂	f ₂	i ₂	s ₂
	H7				JS9	+0,2		j7					
GFL05...	30	140	50	124	8	33.3	200	130	12	165	3.5	33.5	4 x 11
	35				10	38.3						42.5	
GFL06...	40	160	65	140	12	43.3	250	180	15	215	4	41.5	4 x 14
	45				14	48.8						55.5	
GFL07...	50	200	75	175	16	53.8	300	230	17	265	4	55.5	4 x 17.5
	55				18	59.3						60.5	
GFL09...	60	240	95	210	20	64.4	350	250	18	300	5	60.5	8 x 17.5
	70				22	74.9						8 x 17.5	
GFL11...	80	290	105	250	22	85.4	400	300	20	350	5	60.5	8 x 17.5
	80				28	85.4						8 x 17.5	
GFL14...	100	350	135	305	28	106.4	450	350	22	400	5	60.5	8 x 17.5

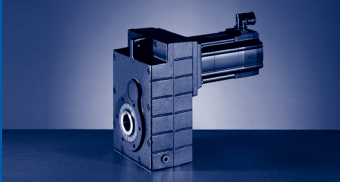

GFL [mm]

GFL□□-3S (MCS)

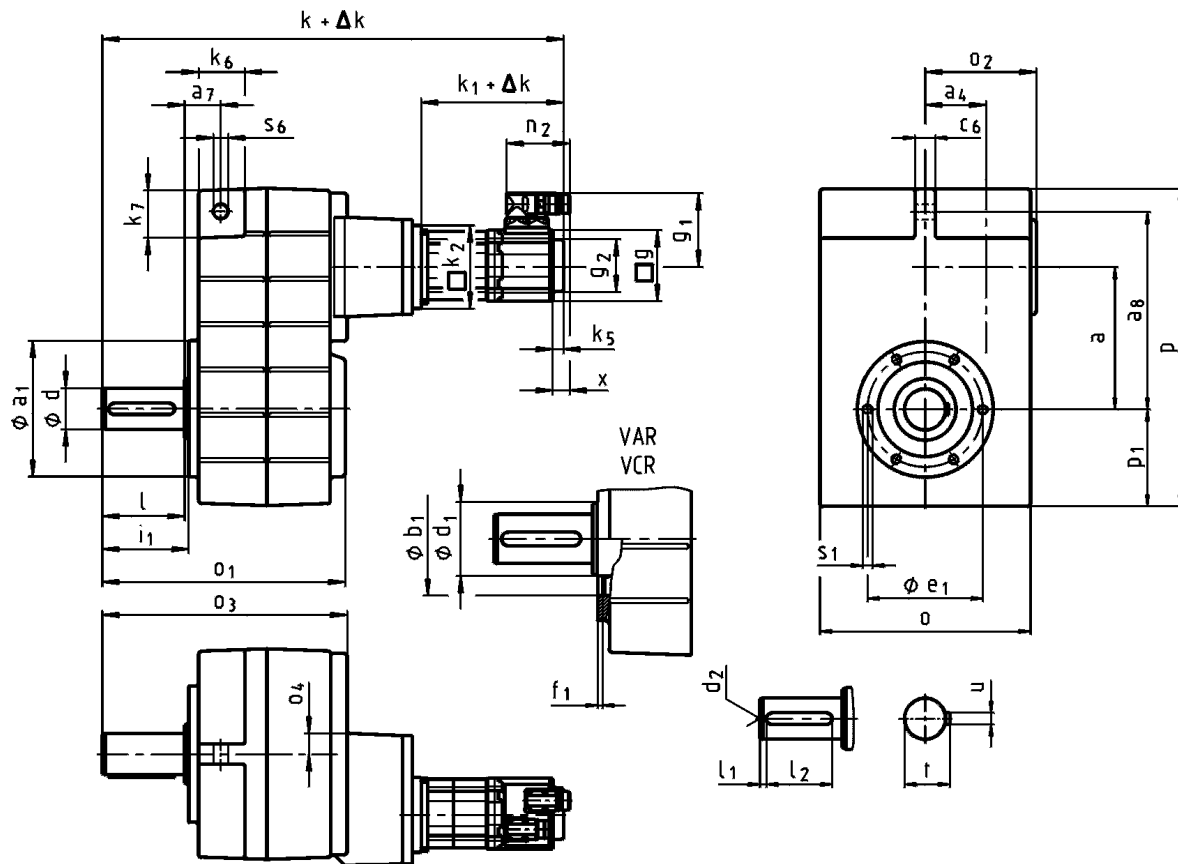

GFL□□-3S V□R ... RSO

		06C C41	06F C41	06I C41	09D C41	09F C38	09H C41	09L C41	12D C20	12D C41	12H C15	12H C30	12H C35	12L C20	12L C41
GFL05...	k	418	448	478	470	490	510	550							
GFL06...	k	468	498	528	520	540	560	600							
GFL07...	k	532	562	592	584	604	624	664	601		641			681	
GFL09...	k	604	634	664	656	676	696	736	673		713			753	
GFL11...	k				756	776	796	836	773		813			853	
GFL14...	k								892		932			972	

...RSO B0 ¹⁾	Δk	0														
...RSO P□ ¹⁾	Δk	19				20										
	k_1	132	162	192	183	203	223	263	188			228			268	
	k_2	66			91							118				
	g	62			89							116				
...RSO	k_5	0			13							14				
	g_2	□ 62			Ø 67							Ø 72				
	g_1	76			90							105				
	n_2	64							78							
	x					21							18			

¹⁾ → 801 - SRS / SRM / ECN / EQN / EQI / C20

²⁾ GFL07: 12DC20 ... 12LC41

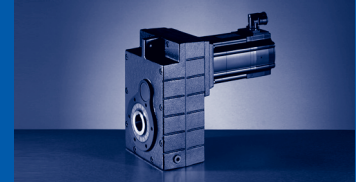

GFL□□-3S V□R ... RSO

		14D C15	14D C36	14H C15	14H C32	14L C15	14L C32	14P C14	14P C32	19F C14	19F C30	19J C14	19J C30	19P C14	19P C30				
GFL09...	k	689		729		769		809											
GFL11...	k	789		829		869		909		828		868		928					
GFL14...	k	908		948		988		1028		947		987		1047					
...RSO B0 ¹⁾	Δ k	0																	
...RSO P□ ¹⁾	Δ k	28						34			44								
	k ₁	201		241		281		321		220		260		320					
	k ₂	145						195											
	g	143						192											
...RSO	k ₅	24						15											
	g ₂	Ø 78																	
	g ₁	116				147		116		147		141		172		141		172	
	n ₂	78				94		78		94		78		94		78		94	
	x	16				38		16		38		16		36		16		36	

¹⁾ → 801 - SRS / SRM / ECN / EQN / EQI / C20

GFL□□-3S V□R

	o	o ₁	o ₂	o ₃	o ₄	p	p ₁	a	a ₄	a ₇	a ₈	c ₆	s ₆	k ₆	k ₇
GFL05...	165	197	107	201	23	252	78	112.5	54.5	29	155	16	14	35	38
GFL06...	206	236	111	240	20	315	98	140	58	35	195	20		46	46
GFL07...	256	296	135	299	24	386	118	173	74	44	240	25	18	56	56
GFL09...	318	356	170	358	27	486	149	220	93.5	50	300	32	22	70	70
GFL11...	395	445	216	445	34	600	181	276.5	120	65	375	40	26	84	90
GFL14...	490	544	271	540	38	740	228	339	154	80	455	50	32	100	114

	d	l	d ₁	l ₁	l ₂	d ₂	u	t	a ₁	b ₁	e ₁	f ₁	i ₁	s ₁
										H7				6x60°
GFL05...	30	60	50	6	45	M10	8	33	118	80	100	4	64	M8x15
GFL06...	40	80	65	7	63	M16	12	43	140	100	120		85	M10x16
GFL07...	50	100	75	8	80		14	53.5	165	115	140	5	105	M12x18
GFL09...	60	120	95		100	M20	18	64	205	145	175	6	125	M16x24
GFL11...	80	160	105	125	22		85	240	140	205	166		M20x32	
GFL14...	100	200	135	18	160	M24	28	106	290	170	250	207	M24x35	

d ≤ 50 mm: k6; d > 50 mm: m6

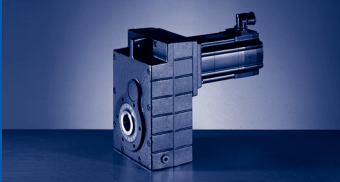

GFL [mm]

GFL□□-3S (MCS)

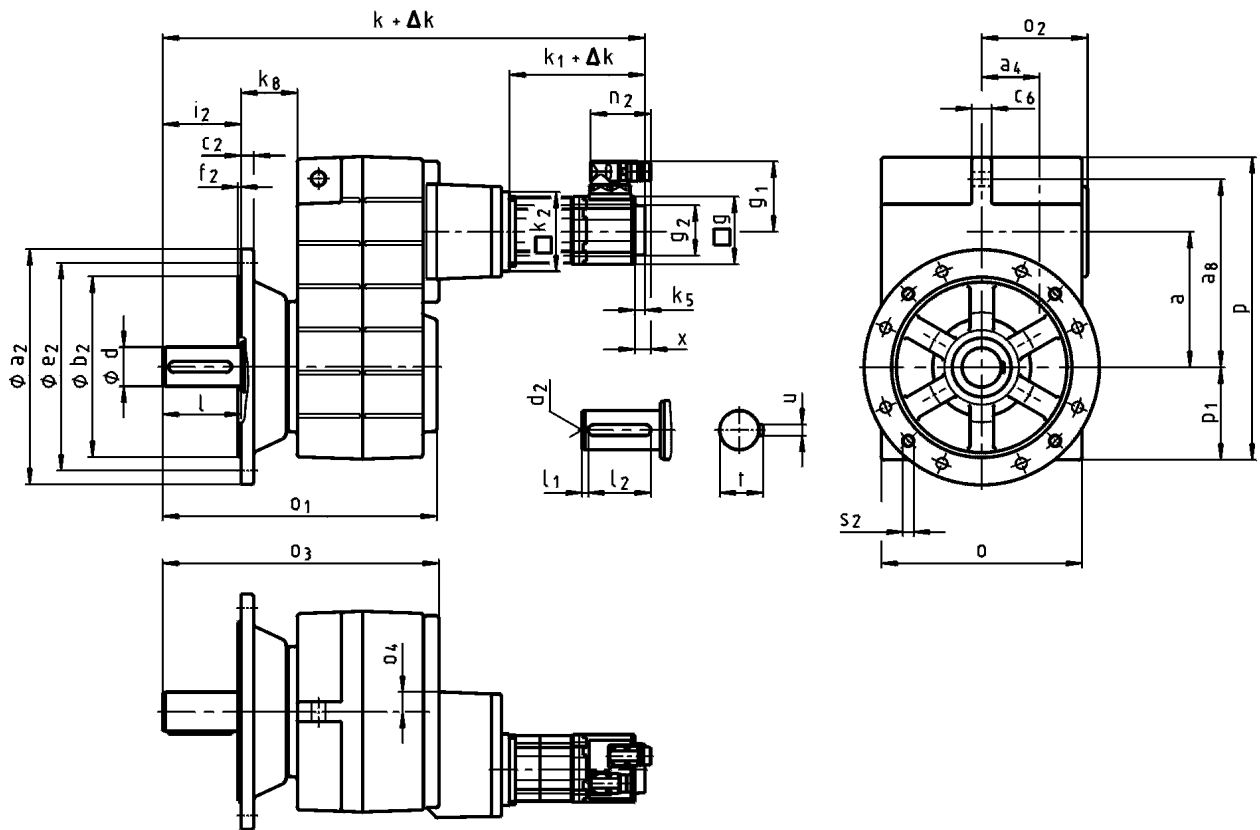

GFL□□-3S VCK ... RSO

		06C C41	06F C41	06I C41	09D C41	09F C38	09H C41	09L C41	12D C20	12D C41	12H C15	12H C30	12H C35	12L C20	12L C41	
GFL05...	k	451	481	511	504	524	544	584								
GFL06...	k	509	539	569	562	582	602	642								
GFL07...	k	587	617	647	640	660	680	720	657			697			737	
GFL09...	k	664	694	724	717	737	757	797	734			774			814	
GFL11...	k				817	837	857	897	834			874			914	
GFL14...	k								953			993			1033	
...RSO B0 ¹⁾	Δ k	0														
...RSO P□ ¹⁾	Δ k	19				20										
	k ₁	132	162	192	183	203	223	263	188					228		268
	k ₂	66			91							118		145 ²⁾		
	g	62			89							116				
...RSO	k ₅	0			13							14				
	g ₂	□ 62			Ø 67							Ø 72				
	g ₁	76			90							105				
	n ₂	64							78							
	x	21											18			

¹⁾ → 801 - SRS / SRM / ECN / EQN / EQI / C20

²⁾ GFL07: 12DC20 ... 12LC41

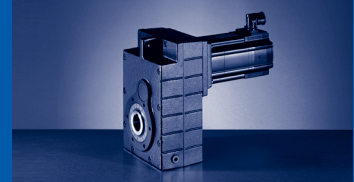

GFL□□-3S VCK ... RSO

		14D C15	14D C36	14H C15	14H C32	14L C15	14L C32	14P C14	14P C32	19F C14	19F C30	19J C14	19J C30	19P C14	19P C30				
GFL09...	k	749		789		829		869											
GFL11...	k	849		889		929		969		888		928		988					
GFL14...	k	968		1008		1048		1088		1007		1047		1107					
...RSO B0 ¹⁾	Δ k	0																	
...RSO P□ ¹⁾	Δ k	28						34			44								
	k ₁	201		241		281		321		220		260		320					
	k ₂	145						195											
	g	143						192											
...RSO	k ₅	24						15											
	g ₂	Ø 78																	
	g ₁	116				147		116		147		141		172		141		172	
	n ₂	78				94		78		94		78		94		78		94	
	x	16				38		16		38		16		36		16		36	

1) → 801 - SRS / SRM / ECN / EQN / EQI / C20

GFL□□-3S VCK

	o	o ₁	o ₂	o ₃	o ₄	p	p ₁	a	a ₄	k ₈
GFL05...	165	230	107	234	23	252	78	112.5	54.5	46
GFL06...	206	277	111	281	20	315	98	140	58	56
GFL07...	256	351	135	354	24	386	118	173	74	73
GFL09...	318	416	170	418	27	486	149	220	93.5	78
GFL11...	395	505	216	505	34	600	181	276.5	120	86
GFL14...	490	604	271	600	38	740	228	339	154	90

	d	l	l ₁	l ₂	d ₂	u	t	a ₂	b ₂	c ₂	e ₂	f ₂	i ₂	s ₂
									j7					
GFL05...	30	60	6	45	M10	8	33	200	130	12	165	3.5	60	4 x 11
GFL06...	40	80	7	63	M16	12	43	250	180	15	215	4	80	4 x 14
GFL07...	50	100	8	80		14	53.5	300	230	17	265		100	
GFL09...	60	120		100	M20	18	64	350	250	18	300	5	120	4 x 17.5
GFL11...	80	160	15	125		22	85	400	300	20	350		160	8 x 17.5
GFL14...	100	200	18	160		M24	28	106	450	350	22		400	

d ≤ 50 mm: k6; d > 50 mm: m6

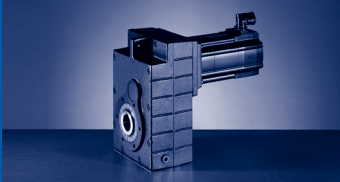

GFL [mm]

GFL□□-2A (MCA)

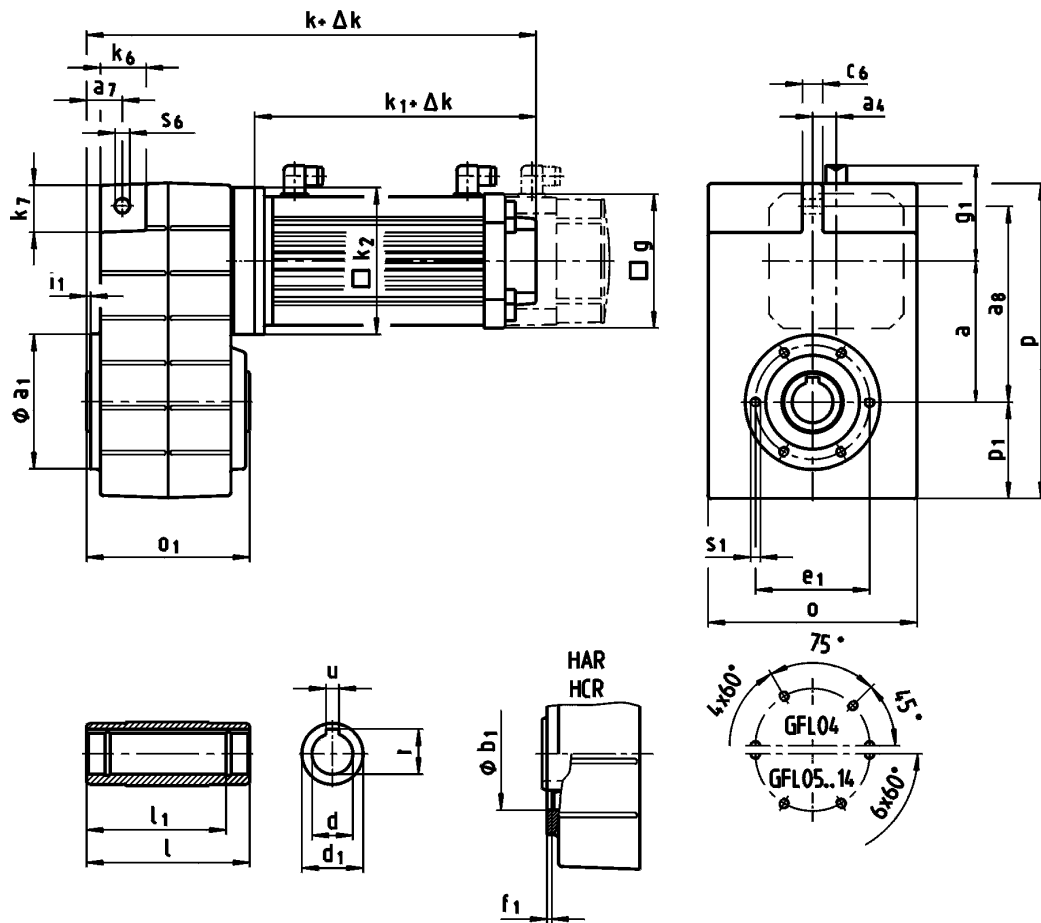

GFL□□-2A H□R ... RSO

		10I C40 ...S00	13I C41 ...S00	13I C34 ...F10	14L C20 ...S00	14L C41 ...S00	14L C16 ...F10	14L C35 ...F10	17N C23 ...S00	17N C41 ...S00
GFL04...	k	388	396	464						
GFL05...	k	409	418	486	468		530			
GFL06...	k	422	431	499	481		543		520	
GFL07...	k	455	464	532	514		576		553	
GFL09...	k				548		610		587	
GFL11...	k				589		651		628	
...RSO B0 ¹⁾	Δk	0								
...RSO P□ ¹⁾	Δk	25	35			33			35	
	k_1	258	267	335	307		369		346	
	k_2	145				180				
	g	102	131			142			165	
	g_1	90	102			109			118	

¹⁾ → 803 - SRS / SRM / ECN / EQN / EQI / S20 / T20 / CDD

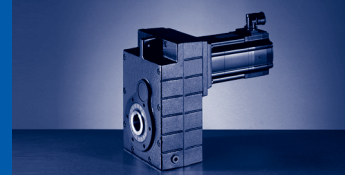

GFL□□-2A H□R ... RSO

		17N C17 ...F10	17N C35 ...F10	19S C23 ...S00	19S C42 ...S00	19S C17 ...F10	19S C35 ...F10	21X C25 ...S00	21X C42 ...S00	21X C17 ...F10	21X C35 ...F10		
GFL06...	k	609											
GFL07...	k	642		621		718		700		796			
GFL09...	k	676		655		752		734		830			
GFL11...	k	717		696		793		775		871			
GFL14...	k			741		838		820		916			
...RSO B0 ¹⁾	Δ k	0											
...RSO P□ ¹⁾	Δ k	35			38			42					
	k ₁	435		408		505		479		575			
	k ₂	180				222				265			
	g	165				192				214			
	g ₁	118				161				172			

¹⁾ →  803 - SRS / SRM / ECN / EQN / EQI / S20 / T20 / CDD

GFL□□-2A H□R

	o	o ₁	p	p ₁	a	a ₄	a ₇	a ₈	c ₆	s ₆	k ₆	k ₇
GFL04...	148	115	214	69	90.5	12.5	22.5	128	14	12.5	32	35
GFL05...	165	140	252	78	112.5	18.5	29	155	16	14	35	38
GFL06...	206	160	315	98	140	22	35	195	20		46	46
GFL07...	256	200	386	118	173	29	44	240	25	18	56	56
GFL09...	318	240	486	149	220	37.5	50	300	32	22	70	70
GFL11...	395	290	600	181	276.5	50	65	375	40	26	84	90
GFL14...	490	350	740	228	339	65	80	455	50	32	100	114

	d	l	d ₁	l ₁	u	t	a ₁	b ₁	e ₁	f ₁	i ₁	s ₁
	H7				JS9	+0,2		H7				
GFL04...	25	115	45	100	8	28.3	110	75	90	3	2.5	M6x12
	30					33.3						
GFL05...	35	140	50	124	10	38.3	118	80	100	4	4	M8x15
GFL06...	40	160	65	140	12	43.3	140	100	120			
	45				14	48.8						
GFL07...	50	200	75	175	14	53.8	165	115	140	5	5	M12x18
	55				16	59.3						
GFL09...	60	240	95	210	18	64.4	205	145	175	6	6	M16x24
	70				20	74.9						
GFL11...	80	290	105	250	22	85.4	240	140	205	6	6	M20x32
	80				22	85.4						
GFL14...	100	350	135	305	28	106.4	290	170	250	6	7	M24x35

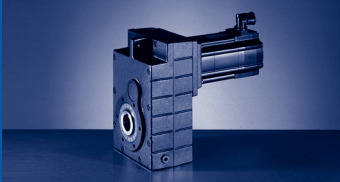

GFL [mm]

GFL□□-2A (MCA)

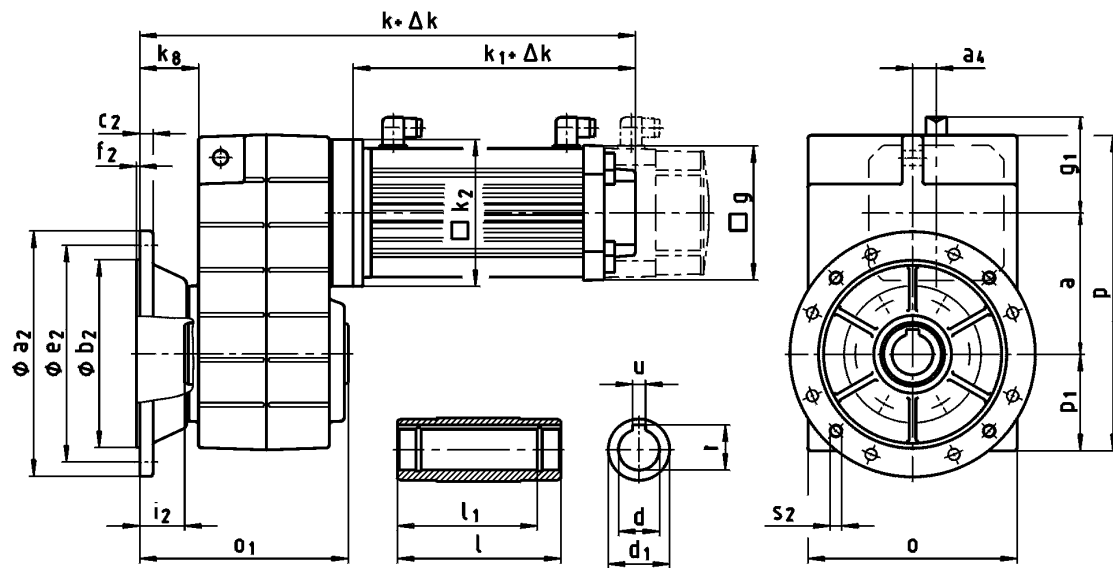

GFL□□-2A HCK ... RSO

		10I C40 ...S00	13I C41 ...S00	13I C34 ...F10	14L C20 ...S00	14L C41 ...S00	14L C16 ...F10	14L C35 ...F10	17N C23 ...S00	17N C41 ...S00
GFL04...	k	421	430	498						
GFL05...	k	443	451	519	501		563			
GFL06...	k	465	473	541	523		585		562	
GFL07...	k	511	519	587	569		631		608	
GFL09...	k				608		670		647	
GFL11...	k				649		711		688	
...RSO B0 ¹⁾	Δk				0					
...RSO P□ ¹⁾	Δk	25	35			33			35	
	k_1	258	267	335	307		369		346	
	k_2	145					180			
	g	102	131			142			165	
	g_1	90	102			109			118	

¹⁾ → 803 - SRS / SRM / ECN / EQN / EQI / S20 / T20 / CDD

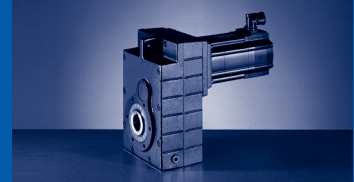

GFL□□-2A HCK ... RSO

		17N C17 ...F10	17N C35 ...F10	19S C23 ...S00	19S C42 ...S00	19S C17 ...F10	19S C35 ...F10	21X C25 ...S00	21X C42 ...S00	21X C17 ...F10	21X C35 ...F10		
GFL06...	k	651											
GFL07...	k	697		677		774		755		851			
GFL09...	k	736		716		813		794		890			
GFL11...	k	777		757		854		835		931			
GFL14...	k			802		899		880		976			
...RSO B0 ¹⁾	Δ k	0											
...RSO P□ ¹⁾	Δ k	35			38			42					
	k ₁	435		408		505		479		575			
	k ₂	180				222				265			
	g	165				192				214			
	g ₁	118				161				172			

1) → 803 - SRS / SRM / ECN / EQN / EQI / S20 / T20 / CDD

GFL□□-2A HCK

	o	o ₁	p	p ₁	a	a ₄	k ₈
GFL04...	148	148	214	69	90.5	12.5	42
GFL05...	165	173	252	78	112.5	18.5	46
GFL06...	206	201	315	98	140	22	56
GFL07...	256	255	386	118	173	29	73
GFL09...	318	300	486	149	220	37.5	78
GFL11...	395	350	600	181	276.5	50	86
GFL14...	490	410	740	228	339	65	90

	d	l	d ₁	l ₁	u	t	a ₂	b ₂	c ₂	e ₂	f ₂	i ₂	s ₂
	H7				JS9	+0,2		j7					
GFL04...	25	115	45	100	8	28.3	160	110	10	130	3.5	33.5	4 x 9
	30					33.3							
GFL05...	35	140	50	124	10	38.3	200	130	12	165			4 x 11
GFL06...	40	160	65	140	12	43.3	250	180	15	215	4	42.5	4 x 14
	45				48.8	41.5							
GFL07...	50	200	75	175	14	53.8	300	230	17	265	5	55.5	4 x 17.5
	55				59.3	60.5							
GFL09...	60	240	95	210	18	64.4	350	250	18	300			8 x 17.5
	70				74.9	400	300	20	350				
GFL11...	80	290	105	250	22	85.4	450	350	22	400			
GFL14...	100	350	135	305	28	106.4							

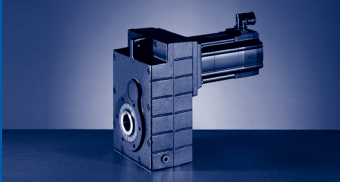

GFL [mm]

GFL□□-2A (MCA)

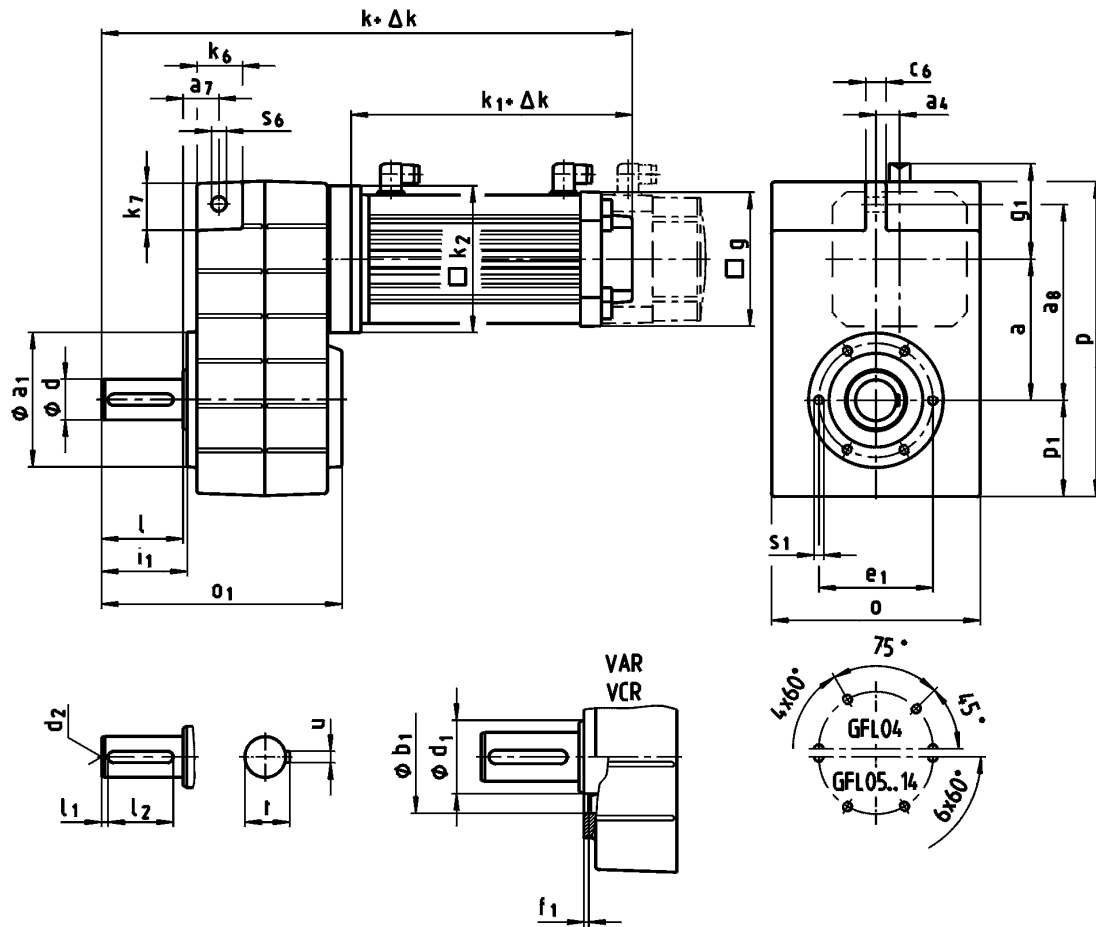

GFL□□-2A V□R ... RSO

		10I C40 ...S00	13I C41 ...S00	13I C34 ...F10	14L C20 ...S00	14L C41 ...S00	14L C16 ...F10	14L C35 ...F10	17N C23 ...S00	17N C41 ...S00
GFL04...	k	438	446	514			590			
GFL05...	k	469	478	546	528					
GFL06...	k	502	511	579	561		623		600	
GFL07...	k	555	564	632	614		676		653	
GFL09...	k				668		730		707	
GFL11...	k				749		811		788	
...RSO B0 ¹⁾	Δk					0				
...RSO P□ ¹⁾	Δk	25	35			33			35	
	k_1	258	267	335	307		369		346	
	k_2		145				180			
	g	102	131			142			165	
	g_1	90	102			109			118	

¹⁾ → 803 - SRS / SRM / ECN / EQN / EQI / S20 / T20 / CDD

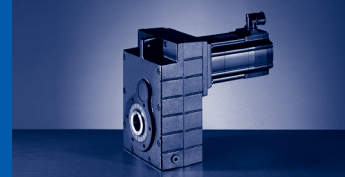

GFL□□-2A V□R ... RSO

		17N C17 ...F10	17N C35 ...F10	19S C23 ...S00	19S C42 ...S00	19S C17 ...F10	19S C35 ...F10	21X C25 ...S00	21X C42 ...S00	21X C17 ...F10	21X C35 ...F10
GFL06...	k	689									
GFL07...	k	742		721		818		800		896	
GFL09...	k	796		775		872		854		950	
GFL11...	k	877		856		953		935		1031	
GFL14...	k			941		1038		1020		1116	
...RSO B0 ¹⁾	Δ k	0									
...RSO P□ ¹⁾	Δ k	35		38				42			
	k ₁	435		408		505		479		575	
	k ₂	180				222				265	
	g	165				192				214	
	g ₁	118				161				172	

¹⁾ →  803 - SRS / SRM / ECN / EQN / EQI / S20 / T20 / CDD

GFL□□-2A V□R

	o	o ₁	p	p ₁	a	a ₄	a ₇	a ₈	c ₆	s ₆	k ₆	k ₇
GFL04...	148	163	214	69	90.5	12.5	22.5	128	14	12.5	32	35
GFL05...	165	197	252	78	112.5	18.5	29	155	16	14	35	38
GFL06...	206	236	315	98	140	22	35	195	20		46	46
GFL07...	256	296	386	118	173	29	44	240	25	18	56	56
GFL09...	318	356	486	149	220	37.5	50	300	32	22	70	70
GFL11...	395	445	600	181	276.5	50	65	375	40	26	84	90
GFL14...	490	544	740	228	339	65	80	455	50	32	100	114

	d	l	d ₁	l ₁	l ₂	d ₂	u	t	a ₁	b ₁	e ₁	f ₁	i ₁	s ₁
GFL04...	25	50	45	4	40	M10	8	28	110	75	90	3	52.5	M6x12
GFL05...	30	60	50	6	45			33	118	80	100			
GFL06...	40	80	65	7	63	M16	12	43	140	100	120	5	105	M10x16
GFL07...	50	100	75	8	80			14	53.5	165	115			
GFL09...	60	120	95		100	M20	18	64	205	145	175	166	M16x24	
GFL11...	80	160	105	125	22				85	240	140			205
GFL14...	100	200	135	18	160	M24	28	106	290	170	250	M24x35		

d ≤ 50 mm: k6; d > 50 mm: m6

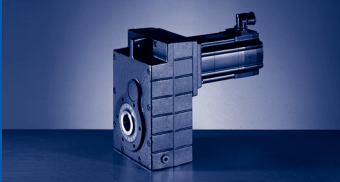

GFL [mm]

GFL□□-2A (MCA)

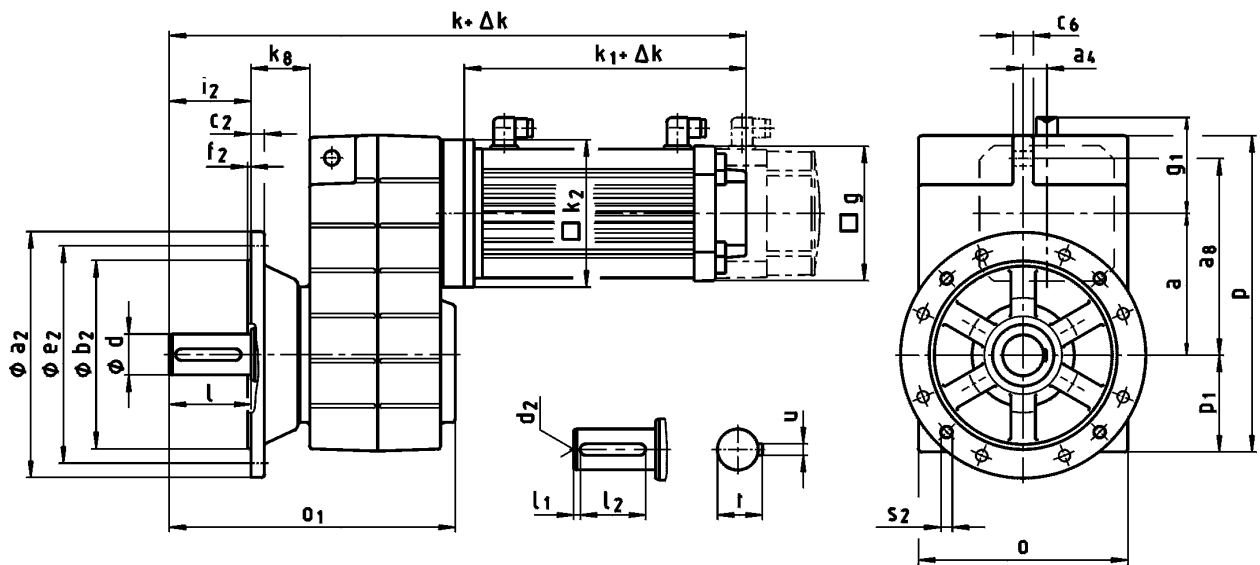

GFL□□-2A VCK ... RSO

		10L C40 ...S00	13L C41 ...S00	13L C34 ...F10	14L C20 ...S00	14L C41 ...S00	14L C16 ...F10	14L C35 ...F10	17N C23 ...S00	17N C41 ...S00
GFL04...	k	471	480	548						
GFL05...	k	502	511	579	561		623			
GFL06...	k	543	552	620	602		664		641	
GFL07...	k	610	619	687	669		731		708	
GFL09...	k				728		790		767	
GFL11...	k				809		871		848	
...RSO B0 ¹⁾	Δk				0					
...RSO P□ ¹⁾	Δk	25	35			33			35	
	k_1	258	267	335	307		369		346	
	k_2		145				180			
	g	102	131			142			165	
	g_1	90	102			109			118	

¹⁾ → 803 - SRS / SRM / ECN / EQN / EQI / S20 / T20 / CDD

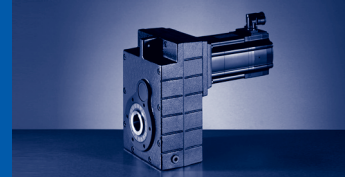

GFL□□-2A VCK ... RSO

		17N C17 ...F10	17N C35 ...F10	19S C23 ...S00	19S C42 ...S00	19S C17 ...F10	19S C35 ...F10	21X C25 ...S00	21X C42 ...S00	21X C17 ...F10	21X C35 ...F10
GFL06...	k	730									
GFL07...	k	797		776		873		855		951	
GFL09...	k	856		835		932		914		1010	
GFL11...	k	937		916		1013		995		1091	
GFL14...	k			1001		1098		1080		1176	
...RSO B0 ¹⁾	Δ k	0									
...RSO P□ ¹⁾	Δ k	35		38				42			
	k ₁	435		408		505		479		575	
	k ₂	180		222				265			
	g	165		192				214			
	g ₁	118		161				172			

1) →  803 - SRS / SRM / ECN / EQN / EQI / S20 / T20 / CDD

GFL□□-2A VCK

	o	o ₁	p	p ₁	a	a ₄	k _g
GFL04...	148	196	214	69	90.5	12.5	42
GFL05...	165	230	252	78	112.5	18.5	46
GFL06...	206	277	315	98	140	22	56
GFL07...	256	351	386	118	173	29	73
GFL09...	318	416	486	149	220	37.5	78
GFL11...	395	505	600	181	276.5	50	86
GFL14...	490	604	740	228	339	65	90

	d	l	l ₁	l ₂	d ₂	u	t	a ₂	b ₂	c ₂	e ₂	f ₂	i ₂	s ₂
									j7					
GFL04...	25	50	4	40	M10	8	28	160	110	10	130	3.5	50	4 x 9
GFL05...	30	60	6	45			33	200	130	12	165		60	4 x 11
GFL06...	40	80	7	63	M16	12	43	250	180	15	215	4	80	4 x 14
GFL07...	50	100	8	80			53.5	300	230	17	265		100	
GFL09...	60	120		100	M20	18	64	350	250	18	300	5	120	4 x 17.5
GFL11...	80	160	15	125			85	400	300	20	350		160	
GFL14...	100	200	18	160	M24	28	106	450	350	22	400		200	8 x 17.5

d ≤ 50 mm: k6; d > 50 mm: m6

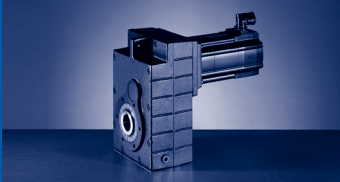

GFL [mm]

GFL□□-3A (MCA)

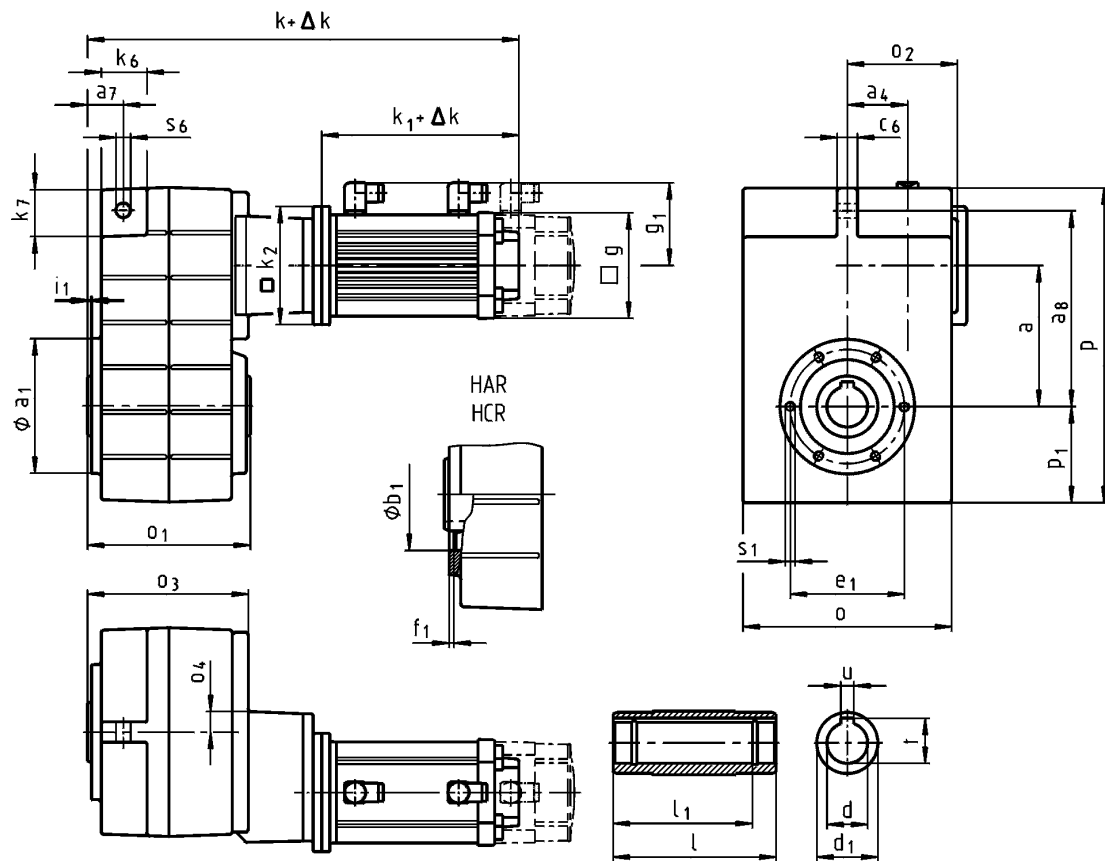

GFL□□-3A H□R ... RSO

		10I C40 ...S00	13I C41 ...S00	13I C34 ...F10	14L C20 ...S00	14L C41 ...S00	14L C16 ...F10	14L C35 ...F10	17N C23 ...S00	17N C41 ...S00
GFL05...	k	486	494	562						
GFL06...	k	516	524	592						
GFL07...	k	560	568	636	618		680			
GFL09...	k	612	620	688	670		732		709	
GFL11...	k	672	680	748	730		792		769	
GFL14...	k				809		871		848	
...RSO B0 ¹⁾	Δk	0								
...RSO P□ ¹⁾	Δk	25	35			33			35	
	k_1	258	267	335	307		369		346	
	k_2	145				180				
	g	102	131			142			165	
	g_1	90	102			109			118	

¹⁾ → 803 - SRS / SRM / ECN / EQN / EQI / S20 / T20 / CDD

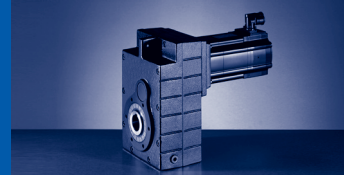

GFL□□-3A H□R ... RSO

		17N C17 ...F10	17N C35 ...F10	19S C23 ...S00	19S C42 ...S00	19S C17 ...F10	19S C35 ...F10	21X C25 ...S00	21X C42 ...S00	21X C17 ...F10	21X C35 ...F10
GFL09...	k	798									
GFL11...	k	858		838		935		916		1012	
GFL14...	k	937		917		1014		995		1091	
...RSO B0 ¹⁾	Δ k	0									
...RSO P□ ¹⁾	Δ k	35		38				42			
	k ₁	435		408		505		479		575	
	k ₂	180				222				265	
	g	165				192				214	
	g ₁	118				161				172	

¹⁾ → 803 - SRS / SRM / ECN / EQN / EQI / S20 / T20 / CDD

GFL□□-3A H□R

	o	o ₁	o ₂	o ₃	o ₄	p	p ₁	a	a ₄	a ₇	a ₈	c ₆	s ₆	k ₆	k ₇
GFL05...	165	140	107	141	23	252	78	112.5	54.5	29	155	16	14	35	38
GFL06...	206	160	111	160	20	315	98	140	58	35	195	20		46	46
GFL07...	256	200	135	199	24	386	118	173	74	44	240	25	18	56	56
GFL09...	318	240	170	238	27	486	149	220	93.5	50	300	32	22	70	70
GFL11...	395	290	216	285	34	600	181	276.5	120	65	375	40	26	84	90
GFL14...	490	350	271	340	38	740	228	339	154	80	455	50	32	100	114

	d	l	d ₁	l ₁	u	t	a ₁	b ₁	e ₁	f ₁	i ₁	s ₁
	H7				JS9	+0,2		H7				6x60°
GFL05...	30	140	50	124	8	33.3	118	80	100	4	4	M8x15
	35				10	38.3						
GFL06...	40	160	65	140	12	43.3	140	100	120	5	5	M10x16
	45				14	48.8						
GFL07...	50	200	75	175	16	53.8	165	115	140	6	6	M12x18
	55				18	64.4						
GFL09...	60	240	95	210	20	74.9	205	145	175	7	7	M16x24
	70				22	85.4						
GFL11...	80	290	105	250	28	106.4	240	140	205	8	8	M20x32
	80				28	106.4						
GFL14...	100	350	135	305	28	106.4	290	170	250	9	9	M24x35

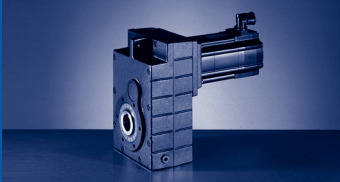

GFL [mm]

GFL□□-3A (MCA)

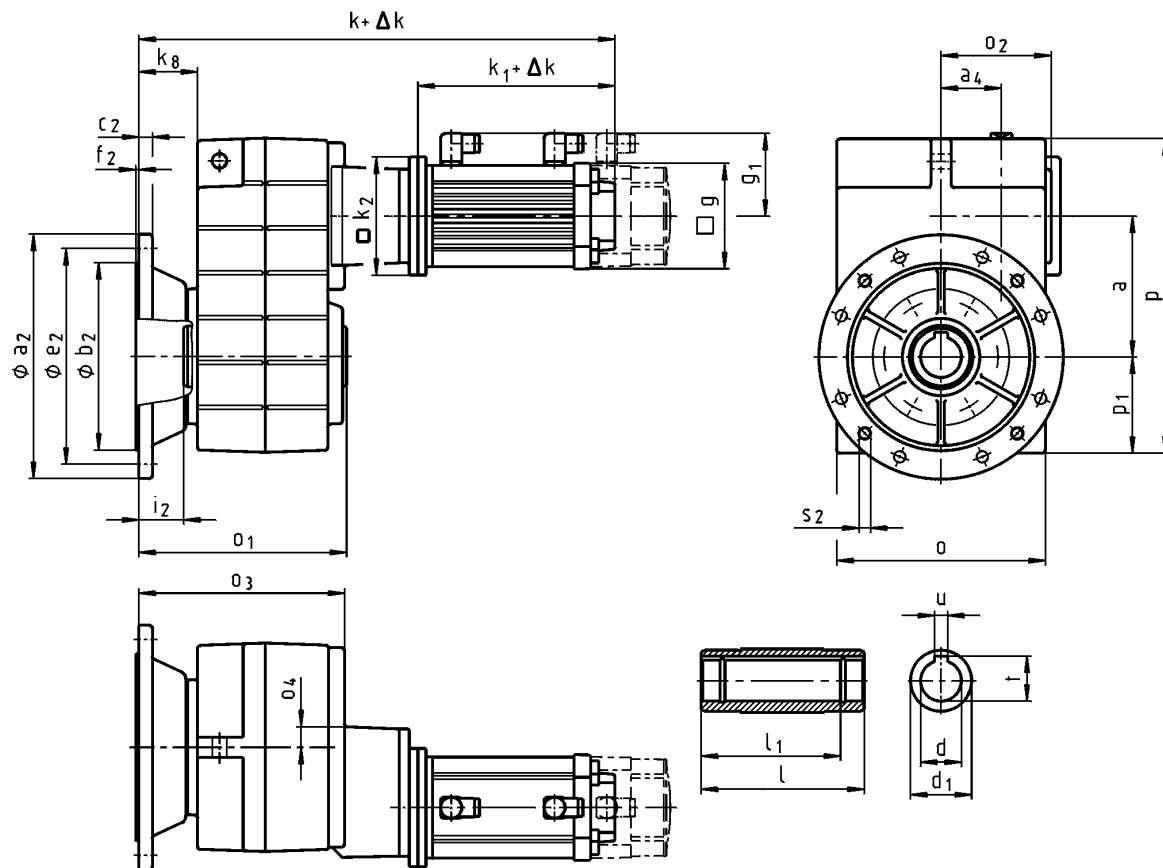

GFL□□-3A HCK ... RSO

		10I C40 ...S00	13I C41 ...S00	13I C34 ...F10	14L C20 ...S00	14L C41 ...S00	14L C16 ...F10	14L C35 ...F10	17N C23 ...S00	17N C41 ...S00
GFL05...	k	519	528	596						
GFL06...	k	558	567	635						
GFL07...	k	615	624	692	674		736			
GFL09...	k	672	681	749	731		793		770	
GFL11...	k	732	741	809	791		853		830	
GFL14...	k				870		932		909	
...RSO B0 ¹⁾	Δk				0					
...RSO P□ ¹⁾	Δk	25	35			33			35	
	k_1	258	267	335	307		369		346	
	k_2		145				180			
	g	102	131			142			165	
	g_1	90	102			109			118	

¹⁾ → 803 - SRS / SRM / ECN / EQN / EQI / S20 / T20 / CDD

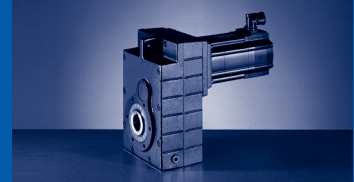

GFL□□-3A HCK ... RSO

		17N C17 ...F10	17N C35 ...F10	19S C23 ...S00	19S C42 ...S00	19S C17 ...F10	19S C35 ...F10	21X C25 ...S00	21X C42 ...S00	21X C17 ...F10	21X C35 ...F10
GFL09...	k	859									
GFL11...	k	919		898		995		977		1073	
GFL14...	k	998		977		1074		1056		1152	
...RSO B0 ¹⁾	Δ k	0									
...RSO P□ ¹⁾	Δ k	35		38				42			
	k ₁	435		408		505		479		575	
	k ₂	180				222				265	
	g	165				192				214	
	g ₁	118				161				172	

¹⁾ → 803 - SRS / SRM / ECN / EQN / EQI / S20 / T20 / CDD

GFL□□-3A HCK

	o	o ₁	o ₂	o ₃	o ₄	p	p ₁	a	a ₄	k _g
GFL05...	165	173	107	174	23	252	78	112.5	54.5	46
GFL06...	206	201	111	201	20	315	98	140	58	56
GFL07...	256	255	135	254	24	386	118	173	74	73
GFL09...	318	300	170	298	27	486	149	220	93.5	78
GFL11...	395	350	216	345	34	600	181	276.5	120	86
GFL14...	490	410	271	400	38	740	228	339	154	90

	d	l	d ₁	l ₁	u	t	a ₂	b ₂	c ₂	e ₂	f ₂	i ₂	s ₂
	H7				JS9	+0,2		j7					
GFL05...	30	140	50	124	8	33.3	200	130	12	165	3.5	33.5	4 x 11
	35				10	38.3							
GFL06...	40	160	65	140	12	43.3	250	180	15	215	4	42.5	4 x 14
	45				14	48.8							
GFL07...	50	200	75	175	16	53.8	300	230	17	265	4	55.5	4 x 17.5
	55				18	64.4							
GFL09...	60	240	95	210	20	74.9	350	250	18	300	5	60.5	4 x 17.5
GFL11...	70				20	74.9	400	300	20	350			
	GFL11...	80	290	105	250	22	85.4	450	350	22	400	5	60.5
GFL14...	100	350	135	305	28	106.4	450	350	22	400	5	60.5	8 x 17.5

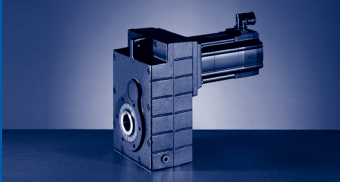

GFL [mm]

GFL□□-3A (MCA)

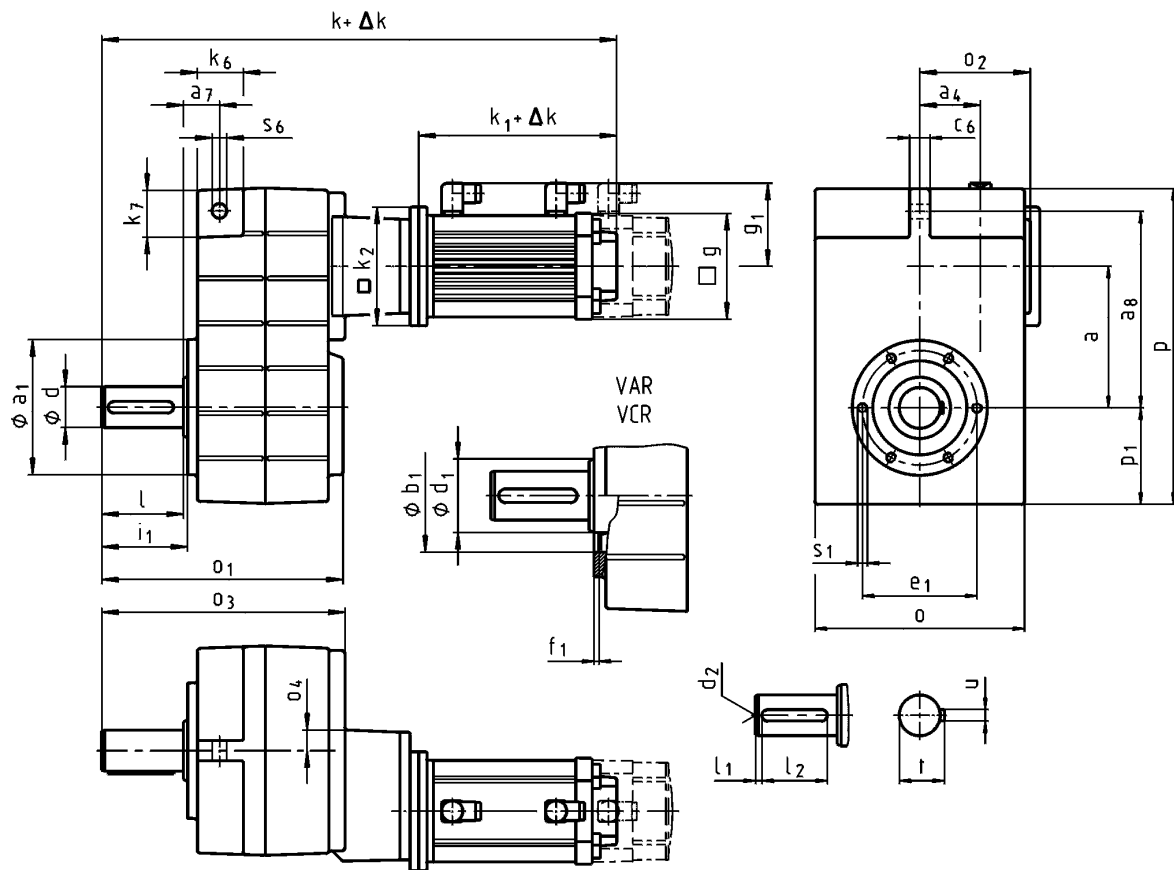

GFL□□-3A V□R ... RSO

		10I C40 ...S00	13I C41 ...S00	13I C34 ...F10	14L C20 ...S00	14L C41 ...S00	14L C16 ...F10	14L C35 ...F10	17N C23 ...S00	17N C41 ...S00
GFL05...	k	546	554	622						
GFL06...	k	596	604	672						
GFL07...	k	660	668	736	718		780			
GFL09...	k	732	740	808	790		852		829	
GFL11...	k	832	840	908	890		952		929	
GFL14...	k				1009		1071		1048	
...RSO B0 ¹⁾	Δk				0					
...RSO P□ ¹⁾	Δk	25	35			33			35	
	k_1	258	267	335	307		369		346	
	k_2		145				180			
	g	102	131			142			165	
	g_1	90	102			109			118	

¹⁾ → 803 - SRS / SRM / ECN / EQN / EQI / S20 / T20 / CDD

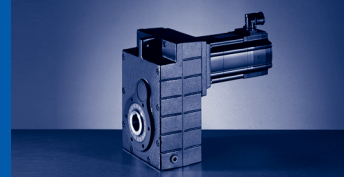

GFL□□-3A V□R ... RSO

		17N C17 ...F10	17N C35 ...F10	19S C23 ...S00	19S C42 ...S00	19S C17 ...F10	19S C35 ...F10	21X C25 ...S00	21X C42 ...S00	21X C17 ...F10	21X C35 ...F10
GFL09...	k	918				1095		1076		1172	
GFL11...	k	1018		998		1095		1076		1172	
GFL14...	k	1137		1117		1214		1195		1291	
...RSO B0 ¹⁾	Δ k	0									
...RSO P□ ¹⁾	Δ k	35		38				42			
	k ₁	435		408		505		479		575	
	k ₂	180				222				265	
	g	165				192				214	
	g ₁	118				161				172	

¹⁾ → 803 - SRS / SRM / ECN / EQN / EQI / S20 / T20 / CDD

GFL□□-3A V□R

	o	o ₁	o ₂	o ₃	o ₄	p	p ₁	a	a ₄	a ₇	a ₈	c ₆	s ₆	k ₆	k ₇
GFL05...	165	197	107	201	23	252	78	112.5	54.5	29	155	16	14	35	38
GFL06...	206	236	111	240	20	315	98	140	58	35	195	20		46	46
GFL07...	256	296	135	299	24	386	118	173	74	44	240	25	18	56	56
GFL09...	318	356	170	358	27	486	149	220	93.5	50	300	32	22	70	70
GFL11...	395	445	216	445	34	600	181	276.5	120	65	375	40	26	84	90
GFL14...	490	544	271	540	38	740	228	339	154	80	455	50	32	100	114

	d	l	d ₁	l ₁	l ₂	d ₂	u	t	a ₁	b ₁	e ₁	f ₁	i ₁	s ₁
										H7				6x60°
GFL05...	30	60	50	6	45	M10	8	33	118	80	100	4	64	M8x15
GFL06...	40	80	65	7	63	M16	12	43	140	100	120		85	M10x16
GFL07...	50	100	75	8	80		14	53.5	165	115	140	5	105	M12x18
GFL09...	60	120	95		100	M20	18	64	205	145	175		125	M16x24
GFL11...	80	160	105	15	125		22	85	240	140	205	6	166	M20x32
GFL14...	100	200	135	18	160	M24	28	106	290	170	250		207	M24x35

d ≤ 50 mm: k6; d > 50 mm: m6

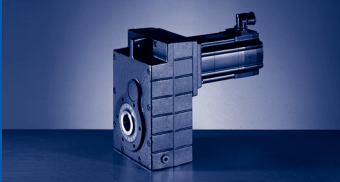

GFL [mm]

GFL□□-3A (MCA)

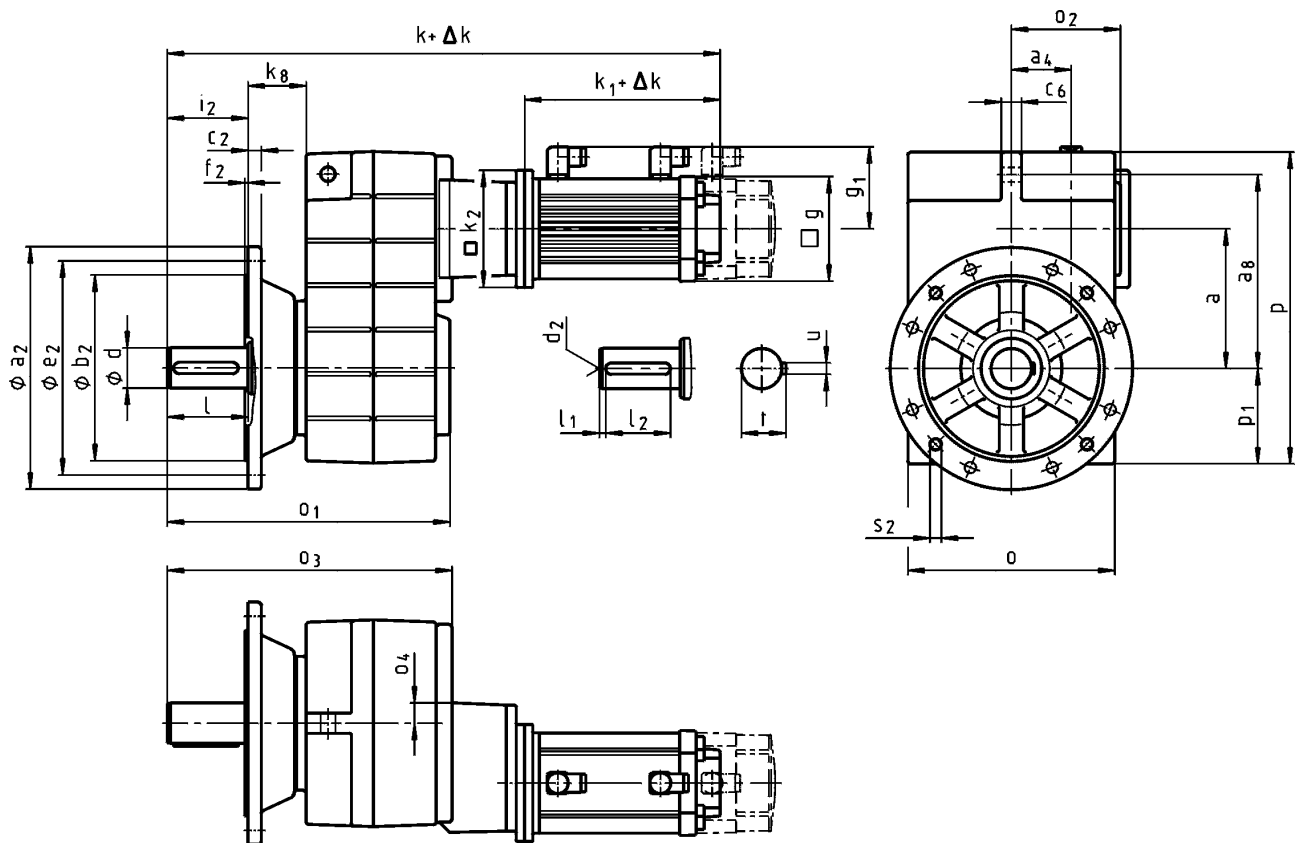

GFL□□-3A VCK ... RSO

		10I C40 ...S00	13I C41 ...S00	13I C34 ...F10	14L C20 ...S00	14L C41 ...S00	14L C16 ...F10	14L C35 ...F10	17N C23 ...S00	17N C41 ...S00
GFL05...	k	579	588	656						
GFL06...	k	637	646	714						
GFL07...	k	715	724	792	774		836			
GFL09...	k	792	801	869	851		913		890	
GFL11...	k	892	901	969	951		1013		990	
GFL14...	k				1070		1132		1109	
...RSO B0 ¹⁾	Δk					0				
...RSO P□ ¹⁾	Δk	25	35			33			35	
	k_1	258	267	335		307		369		346
	k_2		145					180		
	g	102	131			142			165	
	g_1	90	102			109			118	

¹⁾ → 803 - SRS / SRM / ECN / EQN / EQI / S20 / T20 / CDD

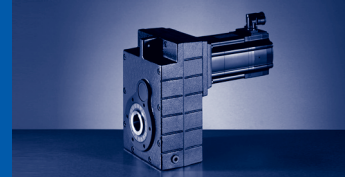

GFL□□-3A VCK ... RSO

		17N C17 ...F10	17N C35 ...F10	19S C23 ...S00	19S C42 ...S00	19S C17 ...F10	19S C35 ...F10	21X C25 ...S00	21X C42 ...S00	21X C17 ...F10	21X C35 ...F10
GFL09...	k	979									
GFL11...	k	1079		1058		1155		1137		1233	
GFL14...	k	1198		1177		1274		1256		1352	
...RSO B0 ¹⁾	Δ k	0									
...RSO P□ ¹⁾	Δ k	35		38				42			
	k ₁	435		408		505		479		575	
	k ₂	180				222				265	
	g	165				192				214	
	g ₁	118				161				172	

¹⁾ →  803 - SRS / SRM / ECN / EQN / EQI / S20 / T20 / CDD

GFL□□-3A VCK

	o	o ₁	o ₂	o ₃	o ₄	p	p ₁	a	a ₄	k ₈
GFL05...	165	230	107	234	23	252	78	112.5	54.5	46
GFL06...	206	277	111	281	20	315	98	140	58	56
GFL07...	256	351	135	354	24	386	118	173	74	73
GFL09...	318	416	170	418	27	486	149	220	93.5	78
GFL11...	395	505	216	505	34	600	181	276.5	120	86
GFL14...	490	604	271	600	38	740	228	339	154	90

	d	l	l ₁	l ₂	d ₂	u	t	a ₂	b ₂	c ₂	e ₂	f ₂	i ₂	s ₂
GFL05...	30	60	6	45	M10	8	33	200	130	12	165	3.5	60	4 x 11
GFL06...	40	80	7	63	M16	12	43	250	180	15	215	4	80	4 x 14
GFL07...	50	100	8	80		14	53.5	300	230	17	265		100	
GFL09...	60	120		100	M20	18	64	350	250	18	300	5	120	4 x 17.5
GFL11...	80	160	15	125		22	85	400	300	20	350		160	
GFL14...	100	200	18	160	M24	28	106	450	350	22	400		200	8 x 17.5

d ≤ 50 mm: k6; d > 50 mm: m6

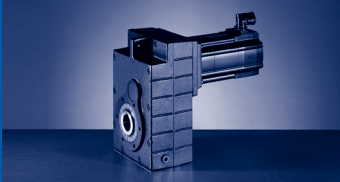

GFL & [mm]

Hollow shaft with shrink disc

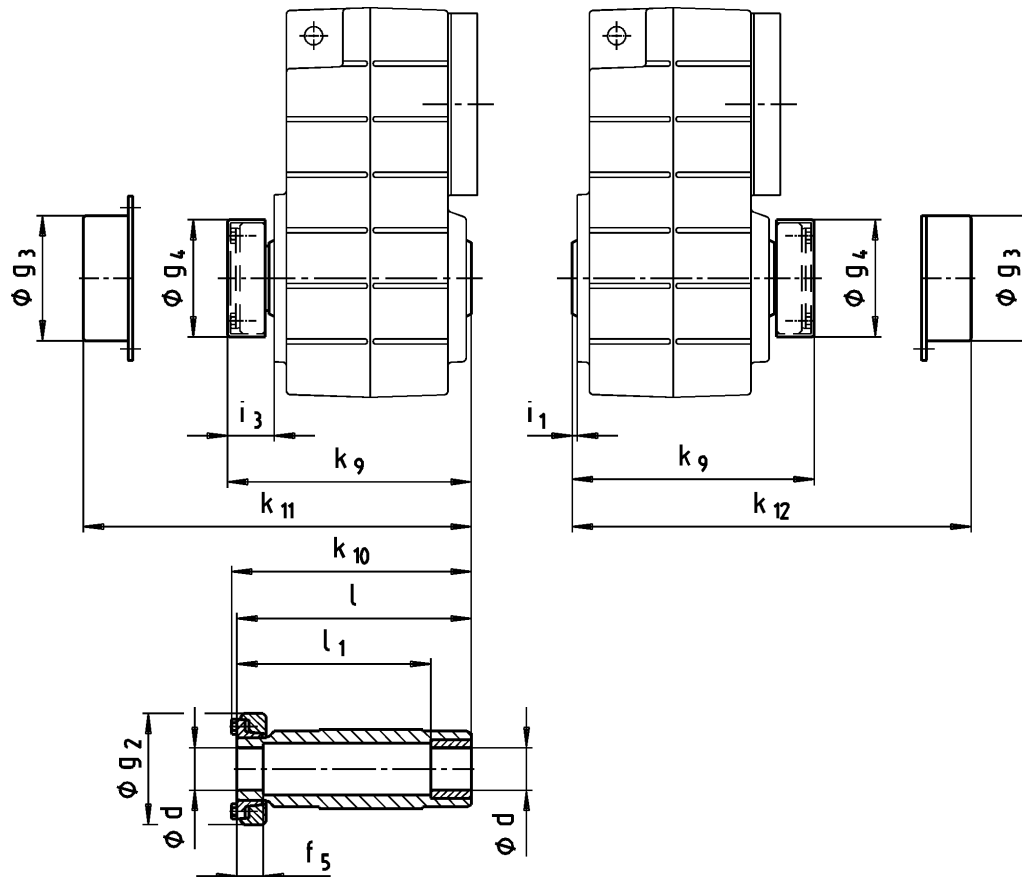

	Machine shaft	Hollow shaft with shrink disc						Protective cap			Cover		
	d	i ₁	k ₁₀	g ₂	l	l ₁	f ₅	i ₃	k ₉	g ₄	k ₁₁	k ₁₂	g ₃
	h6												
GFL04...	25 30	2.5	147.5	72	142	122	26	37	149.5	76	154	154	79
GFL05...	35	4	173.5	80	168	148	28	39.5	175.5	84	179	180	90
GFL06...	40	5	199.5	90	194	164	30	46.5	201.5	94	204	205	100
GFL07...	50		237.5	110	232	192	26	45.5	240.5	116	244	245	124
GFL09...	65		285	141	278	228	30	53	288	147	287	288	159
GFL11...	80	6	344	170	338	238	42	63	347	176	349	350	191
GFL14...	100	7	415	215	407	307	55	75	418	221	421	422	253

- ▶ Ensure that the strength of the shaft material is adequate in shrink disc designs.
When using typical steels (e.g. C45, 42CrMo4), the torques listed in the selection tables can be used without restriction.
When using material that is considerably weaker, please consult us. Medium surface roughness Rz must not exceed 15 µm (turning operation is sufficient).

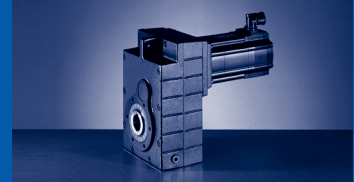

Possible combinations with shrink disc in position 1 (drive end)

GFL□□-2S with motor frame size

	06C C41	06F C41	06I C41	09D C41	09F C38	09H C41	09L C41	12D C20	12D C41	12H C15	12H C30	12H C35	12L C20	12L C41
GFL04...	● 1)	● 1)	● 1)	● 1)	● 1)	● 1)	● 1)							
GFL05...	● 1)	● 1)	● 1)	● 1)	● 1)	● 1)	● 1)							
GFL06...	●	●	●	●	●	●	●	●	●	●	●	●	●	●
GFL07...				●	●	●	●	●	●	●	●	●	●	●
GFL09...								●	●	●	●	●	●	●

	14D C15	14D C36	14H C15	14H C32	14L C15	14L C32	14P C14	14P C32	19F C14	19F C30	19J C14	19J C30	19P C14	19P C30
GFL06...	●	●	●	●	●	●	●	●						
GFL07...	●	●	●	●	●	●	●	●	●	●	●	●	●	●
GFL09...	●	●	●	●	●	●	●	●	●	●	●	●	●	●
GFL11...	●	●	●	●	●	●	●	●	●	●	●	●	●	●
GFL14...									●	●	●	●	●	●

GFL□□-2A with motor frame size

	10I C40 ...S00	13I C41 ...S00	13I C34 ...F10	14L C20 ...S00	14L C41 ...S00	14L C16 ...F10	14L C35 ...F10	17N C23 ...S00	17N C41 ...S00
GFL06...	●	●	●	● 1)	● 1)	● 1)	● 1)	● 1)	● 1)
GFL07...	●	●	●	●	●	●	●	●	●
GFL09...				●	●	●	●	●	●
GFL11...				●	●	●	●	●	●

	17N C17 ...F10	17N C35 ...F10	19S C23 ...S00	19S C42 ...S00	19S C17 ...F10	19S C35 ...F10	21X C25 ...S00	21X C42 ...S00	21X C17 ...F10	21X C35 ...F10
GFL06...	● 1)	● 1)								
GFL07...	●	●	● 1)	● 1)	● 1)	● 1)				
GFL09...	●	●	●	●	●	●	●	●	●	●
GFL11...	●	●	●	●	●	●	●	●	●	●
GFL14...			●	●	●	●	●	●	●	●

1) Only possible without cover

- ▶ GFL□□-2S: Terminal box in position 4 on request only.
- GFL□□-2A: Connector/terminal box in position 4 not possible.
- GFL□□-3□: All versions are possible.

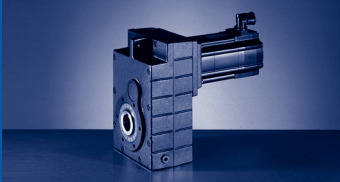

GFL & [mm]

Foot mounting in position 3

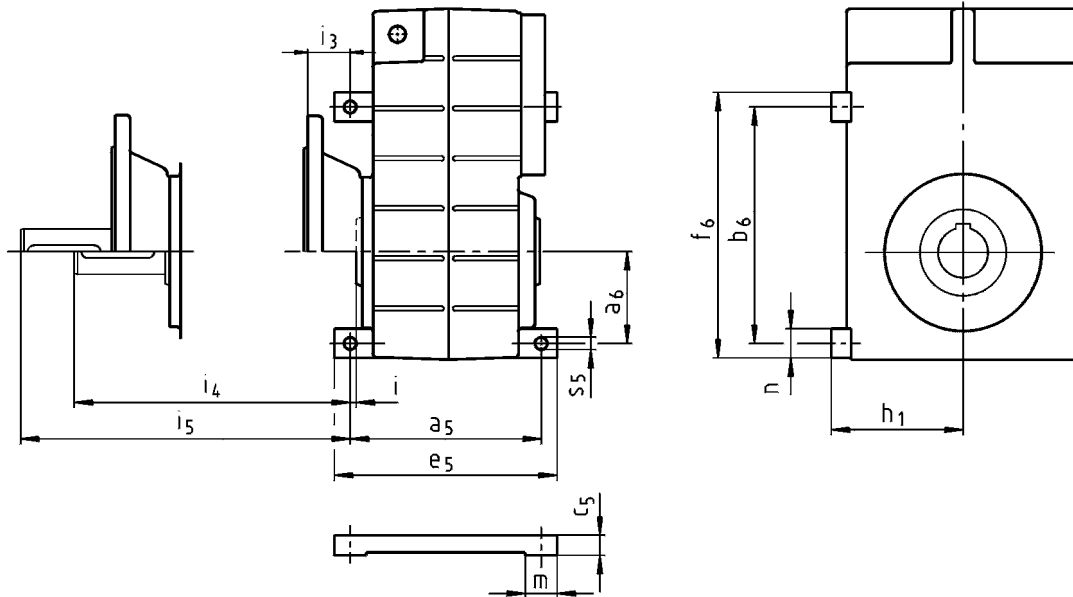

			HAR HBR SAR SBR	HAK SAK	VAR VBR	VAK								
	a ₆	h ₁	i	i ₃	i ₄	i ₅	a ₅	b ₆	c ₅	e ₅	f ₆	n	m	s ₅
GFL04...	47	90	4.5	28.5	45.5	78.5	130	115	18	152	140	25	22	6.6
GFL05...	65	100	2	31	58	91	160	167	21	185	192		25	9
GFL06...	80	125		3	39	78	119	175	205	27	205	233	28	30
GFL07...	100	155	52		97	152	220	260	31	255	292	32	35	13.5
GFL09...	125	190	117		177	260	335	36	300	375	40	40	17.5	
GFL11...	155	240	57		157	217	315	435	48	365	485	50	50	22
GFL14...	200	295		197	257	375	540	57	430	600	60	55	26	

► Terminal box position 3 is not possible for GFL04...06-2A.

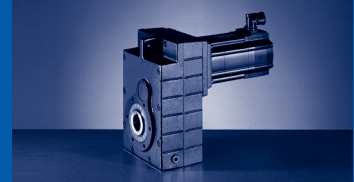

Foot mounting in position 4

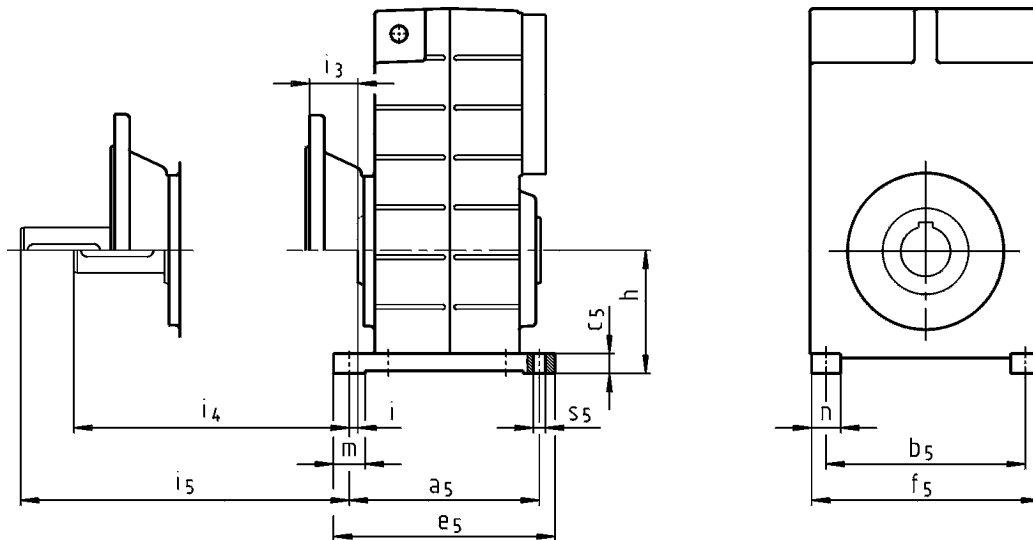

		HAR HBR SAR SBR	HAK SAK	VAR VBR	VAK								
	h	i	i ₃	i ₄	i ₅	a ₅	b ₅	c ₅	e ₅	f ₅	n	m	s ₅
GFL04...	85	4.5	28.5	45.5	78.5	130	108	18	152	133	25	22	6.6
GFL05...	95	2	31	58	91	160	140	21	185	165		25	9
GFL06...	120		39	78	119	175	175	27	205	203	28	30	11
GFL07...	145	3	52	97	152	220	220	31	255	252	32	35	13.5
GFL09...	180		117	177	260	275	36	300	315	40	40	17.5	
GFL11...	224		57	157	217	315	340	48	365	390	50	50	22
GFL14...	278		197	257	375	425	57	430	485	60	55	26	

- In mounting positions E and F, the oil check bore hole/oil-sight glass are located between the feet in position 4!

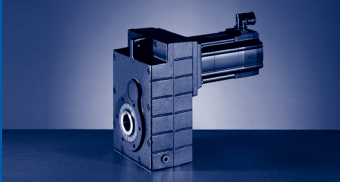

Rubber buffer for torque plate

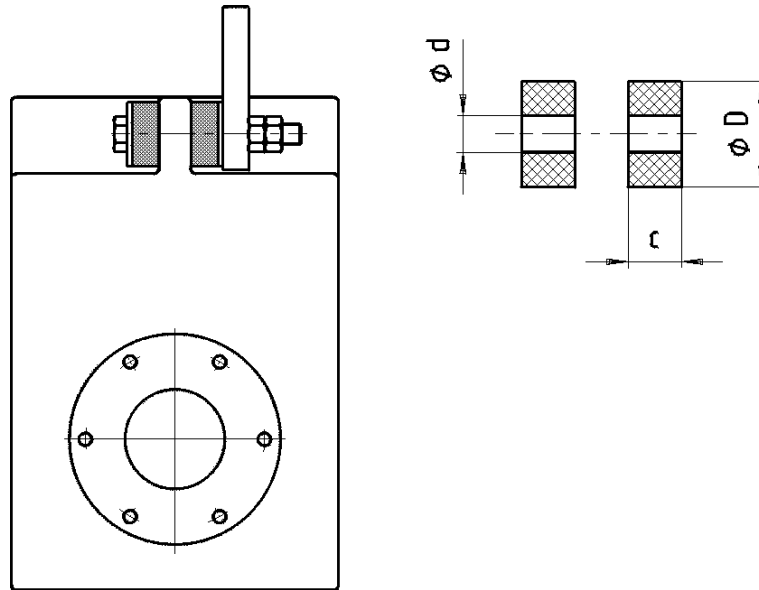

	d	D	c
GFL04...	11	30	14.5
GFL05...			
GFL06...	13	40	15
GFL07...	17	50	27
GFL09...	21	60	28
GFL11...	26	72	29
GFL14...	33	92	30

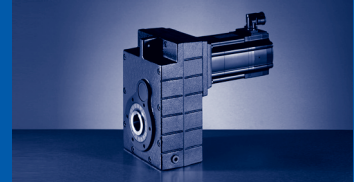

Mounting set for hollow shaft circlip
Proposed design for auxiliary tools

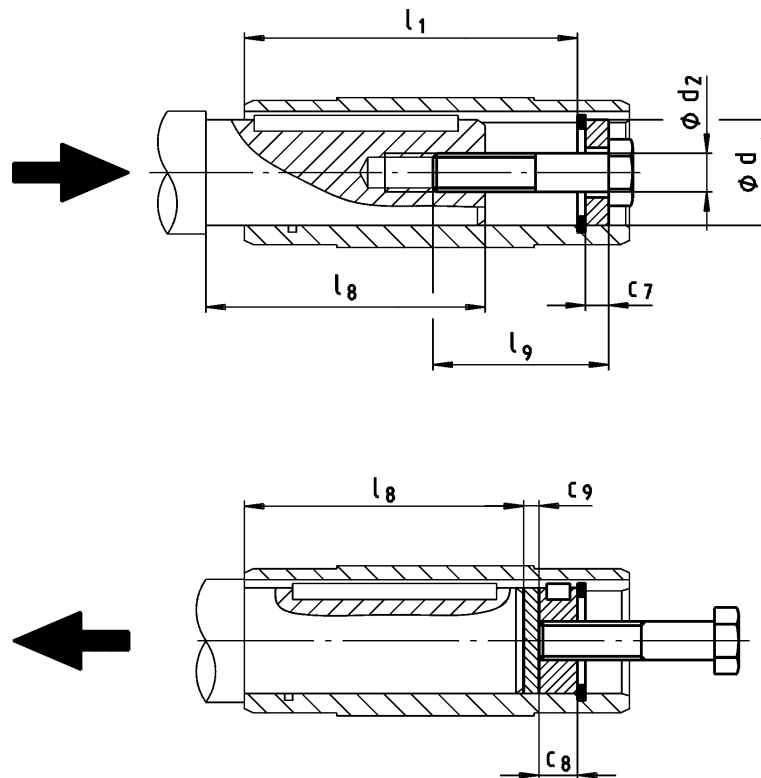

	Hollow shaft		Hollow shaft circlip mounting set (Assembly auxiliaries)			Auxiliary tools Disassembly		Machine shaft
	d	l ₁	d ₂	l ₉	c ₇	c ₈	c ₉	max l ₈
	H7							
GFL04...	25	100	M10	40	5	10	3	85
GFL05...	30				6			
	35	124	M12	50	7	12		107
GFL06...	40	140	M16	60	8	16	4	118
	45				9			
GFL07...	50	175			10			148
	55				11			
GFL09...	60	210	M20	80	13	20	5	182
	70				14			
GFL11...	80	250			16		6	221
GFL14...	100	305	M24	100	20	24	8	270

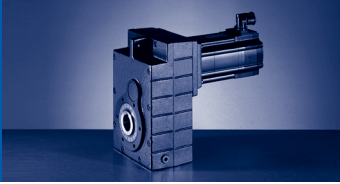

GFL & [mm]

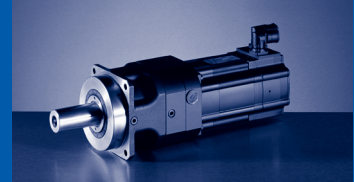

Permissible radial force

$$Fr_{zul} = Fr_{Tab} \text{ at } Fa = 0$$

Permissible axial force

$$Fa_{zul} = Fa_{Tab} \text{ at } Fr = 0$$

At Fr and $Fa \neq 0$ please contact your Lenze sales office

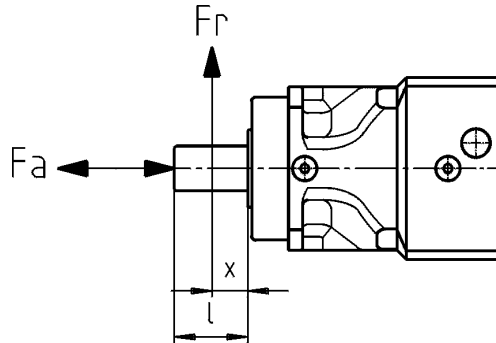

Solid shaft with flange (GCN) Application of force Fr : centre of shaft journal ($x = l/2$) Fa_{Tab} only valid for $Fr = 0$												
	GPA00-1/2		GPA01-1/2		GPA02-1/2		GPA03-1/2		GPA04-1/2		GPA05-1/2	
n_2 [min ⁻¹]	Fr_{Tab} [N]	Fa_{Tab} [N]	Fr_{Tab} [N]	Fa_{Tab} [N]	Fr_{Tab} [N]	Fa_{Tab} [N]	Fr_{Tab} [N]	Fa_{Tab} [N]	Fr_{Tab} [N]	Fa_{Tab} [N]	Fr_{Tab} [N]	Fa_{Tab} [N]
1000	1550	2300	2325	3200	3700	5400	4950	9400	7170	13500	11390	22500
900	1600		2400		3825		5125		7400		11750	
800	1675		2475		3950		5300		7670		12180	
700	1725		2600		4125		5525		7980		12680	
600	1825		2700		4325		5775		8360		13280	
500	1925		2850		4550		6100		8830		14020	
400	2050		3050		4875		6525		9450		15000	
300	2250		3350		5300		7100		10300		16350	
200	2525		3775		6000		8025		11630		18000	
≤ 100	2600		3800		6000		9000		14000		18000	
Fr_{max}												

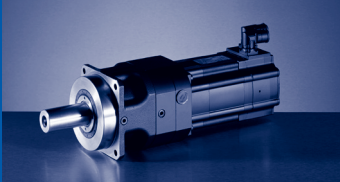

Backlash

Gearbox type	Standard backlash (measured at 2% of gearbox output torque)
	[arcmin]
GPA00-1	Max. 6
GPA01-1	
GPA02-1	
GPA03-1	
GPA04-1	
GPA05-1	

Gearbox type	Standard backlash (measured at 2% of gearbox output torque)
	[arcmin]
GPA00-2	Max. 8
GPA01-2	
GPA02-2	
GPA03-2	
GPA04-2	
GPA05-2	

Torsional stiffness

Gearbox type	Torsional stiffness
	[Nm/arcmin]
GPA00-1	3
GPA01-1	8.8
GPA02-1	23
GPA03-1	47
GPA04-1	145
GPA05-1	225

Gearbox type	Torsional stiffness
	[Nm/arcmin]
GPA00-2	2.8
GPA01-2	8
GPA02-2	20
GPA03-2	42
GPA04-2	125
GPA05-2	195

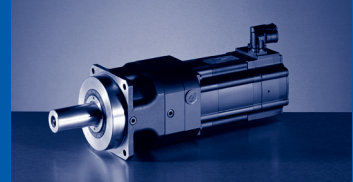

GPA□□-1S GCN...RSO B0

	06C N41	06F N41	06I N41	09D N41	09F N38	09H N41	09L N41	12D N20	12D N41	12H N15	12H N30	12H N35	12L N20	12L N41	
GPA00...	4		5	6	7	8	10								
GPA01...	5	6		8	9	10	11	10		13				16	
GPA02...				11	12	13	14	13		16				19	
GPA03...								21		24				27	
	14D N15	14D N36	14H N15	14H N32	14L N15	14L N32	14P N14	14P N32	19F N14	19F N30	19J N14	19J N30	19P N14	19P N30	
GPA02...	17		22		27		31								
GPA03...	25		30		34		39		37		44		54		
GPA04...										53		60		70	
GPA05...										68		75		85	

GPA□□-2S GCN...RSO B0

	06C N41	06F N41	06I N41	09D N41	09F N38	09H N41	09L N41	12D N20	12D N41	12H N15	12H N30	12H N35	12L N20	12L N41	
GPA00...	5		6												
GPA01...	6	7		9	10	11	12								
GPA02...				13	14	15	17	15		18				21	
GPA03...								26		30				33	
	14D N15	14D N36	14H N15	14H N32	14L N15	14L N32	14P N14	14P N32	19F N14	19F N30	19J N14	19J N30	19P N14	19P N30	
GPA03...	31		36		40		45								
GPA04...										62		69		79	
GPA05...										90		97		107	

Note additional weights.

Weights in [kg] with oil capacity for mounting position A, all given as approximate values

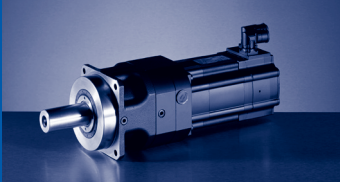

GPA [kg]

GPA□□-1A GCN...RSO B0

	10I N40 ...S00	13I N41 ...S00	13I N34 ...F10	14L N20 ...S00	14L N41 ...S00	14L N16 ...F10	14L N35 ...F10	17N N23 ...S00	17N N41 ...S00
GPA00...	9								
GPA01...	10	14	15						
GPA02...	13	17	19	22		24		29	
GPA03...		26	27	30		32		38	

	17N N17 ...F10	17N N35 ...F10	19S N23 ...S00	19S N42 ...S00	19S N17 ...F10	19S N35 ...F10	21X N25 ...S00	21X N42 ...S00	21X N17 ...F10	21X N35 ...F10
GPA01...										
GPA02...	32									
GPA03...	41		60		63		75		79	
GPA04...			75		78		90		94	
GPA05...			90		94		105		109	

GPA□□-2A GCN...RSO B0

	10I N40 ...S00	13I N41 ...S00	13I N34 ...F10	14L N20 ...S00	14L N41 ...S00	14L N16 ...F10	14L N35 ...F10	17N N23 ...S00	17N N41 ...S00
GPA00...	9								
GPA01...	11	15	16						
GPA02...		19	21	24		26		32	
GPA03...									

	17N N17 ...F10	17N N35 ...F10	19S N23 ...S00	19S N42 ...S00	19S N17 ...F10	19S N35 ...F10	21X N25 ...S00	21X N42 ...S00	21X N17 ...F10	21X N35 ...F10
GPA02...	34									
GPA03...			65		68					
GPA04...			84		88		99		103	
GPA05...			111		115		126		130	

Note additional weights.

Weights in [kg] with oil capacity for mounting position A, all given as approximate values

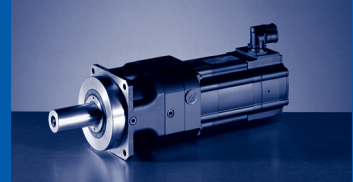

Additional weights MCS servo motors

	06C N41	06F N41	06I N41	09D N41	09F N38	09H N41	09L N41	12D N20	12D N41	12H N15	12H N30	12H N35	12L N20	12L N41
...P1	0.3			0.8				0.9						
...P2				0.5				1.2						
...SCS/SCM/SRM/SRS ...ECN/EQN	0.4			0.2				0.3						

	14D N15	14D N36	14H N15	14H N32	14L N15	14L N32	14P N14	14P N32	19F N14	19F N30	19J N14	19J N30	19P N14	19P N30
...P1	1.9						1.5							
...P2	3.1									4.3				
...SCS/SCM/SRM/SRS ...ECN/EQN							0.3							

Additional weights MCA servo motors

	10I N40 ...S00	13I N41 ...S00	13I N34 ...F10	14L N20 ...S00	14L N41 ...S00	14L N16 ...F10	14L N35 ...F10	17N N23 ...S00	17N N41 ...S00
...P1/P5								2.4	
...P2/P6	0.8	1.4		1.5					
...CDD ...ECN/EQN/EQI ...SCS/SCM/SRM/SRS/S20 ...T20	0.3	0.5		0.6			0.7		

	17N N17 ...F10	17N N35 ...F10	19S N23 ...S00	19S N42 ...S00	19S N17 ...F10	19S N35 ...F10	21X N25 ...S00	21X N42 ...S00	21X N17 ...F10	21X N35 ...F10
...P1/P5	2.4		4.8			5				
...P2/P6										
...CDD ...ECN/EQN/EQI ...SCS/SCM/SRM/SRS/S20 ...T20	0.7		1			1.1				

Weights in [kg]

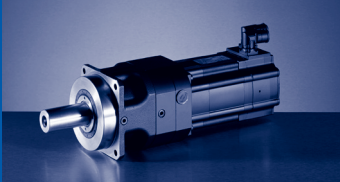

GPA [Nm]

GPA□□-□S (MCS)

$M_{2GN} \leq 25 \text{ Nm}$

GPA00-1S				06CN41	06FN41	06IN41	09FN38	09HN41
				...500	...500	...500	...500	...500
i	M_{2GN}	J_G	M_1	0.6	1.2	1.5	3.1	3.8
			n_1	4050	4050	4050	3750	4050
			I_{M230}	2.6	2.9	3.2	5	6.8
			I_{M400}	1.3	1.5	1.6	2.5	3.4
			P_N	0.25	0.51	0.64	1.2	1.6
			J_M	0.17	0.25	0.33	1.53	1.93
3	20	0.22	M_2		4	4		
			c		5.8	4.6		
			$n_{2 \text{ Eck}}$		1350	1350		
			$n_{2 \text{ th}}$		867	867		
4	25	0.16	M_2		5	6	12	15
			c		5.4	4.4	2.1	1.7
			$n_{2 \text{ Eck}}$		1013	1013	938	1013
			$n_{2 \text{ th}}$		825	825	825	825
5	25	0.13	M_2		6	7	15	19
			c		4.3	3.5	1.7	1.4
			$n_{2 \text{ Eck}}$		810	810	750	810
			$n_{2 \text{ th}}$		660	660	660	660
7	25	0.12	M_2		8	10		
			c		3.1	2.5		
			$n_{2 \text{ Eck}}$		579	579		
			$n_{2 \text{ th}}$		571	571		
10	15	0.11	M_2	6	12	15		
			c	2.5	1.3	1		
			$n_{2 \text{ Eck}}$	405	405	405		
			$n_{2 \text{ th}}$	400	400	400		

GPA00-2S				06CN41	06FN41	06IN41
				...500	...500	...500
i	M_{2GN}	J_G	M_1	0.6	1.2	1.5
			n_1	4050	4050	4050
			I_{M230}	2.6	2.9	3.2
			I_{M400}	1.3	1.5	1.6
			P_N	0.25	0.51	0.64
			J_M	0.17	0.25	0.33
16	25	0.15	M_2	9	18	23
			c	2.8	1.4	1.1
			$n_{2 \text{ Eck}}$	253	253	253
			$n_{2 \text{ th}}$	253	253	253

$M \dots$ [Nm]
 $n \dots$ [min^{-1}]
 $J \dots$ [kgcm^2]

$P \dots$ [kW]
 $I \dots$ [A]
 $i \dots$ [-]
 $c \dots$ [-]

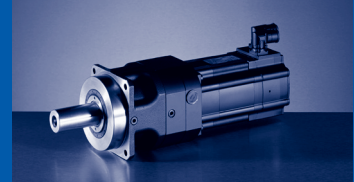

$M_{2GN} \leq 70 \text{ Nm}$

GPA01-1S				06FN41	06IN41	09FN38	09HN41	12HN15	12HN35	12LN20	12LN41
				...500	...500	...500	...500	...500	...500	...500	...500
i	M_{2GN}	J_G	M_1	1.2	1.5	3.1	3.8	10	7.5	13.5	11
			n_1	4050	4050	3750	4050	1500	3525	1950	4050
			I_{M230}	2.9	3.2	5	6.8	7.6		11.8	
			I_{M400}	1.5	1.6	2.5	3.4	3.8	5.7	5.9	10.2
			P_N	0.51	0.64	1.2	1.6	1.6	2.8	2.8	4.7
			J_M	0.25	0.33	1.53	1.93	7.42	7.42	10.72	10.72
3	56	0.71	M_2					29	22	40	32
			c					1.9	2.6	1.4	1.7
			$n_{2 \text{ Eck}}$					500	1175	650	1350
			$n_{2 \text{ th}}$					500	767	650	767
4	70	0.52	M_2					39	29	53	43
			c					1.8	2.4	1.3	1.6
			$n_{2 \text{ Eck}}$					375	881	488	1013
			$n_{2 \text{ th}}$					375	725	488	725
7	70	0.39	M_2			21	26	68	51		
			c			3.3	2.7	1	1.4		
			$n_{2 \text{ Eck}}$			536	579	214	504		
			$n_{2 \text{ th}}$			443	443	214	443		
10	45	0.36	M_2	12	15	30	37				
			c	3.9	3.1	1.5	1.2				
			$n_{2 \text{ Eck}}$	405	405	375	405				
			$n_{2 \text{ th}}$	310	310	310	310				

GPA01-2S				06CN41	06FN41	06IN41	09FN38	09HN41
				...500	...500	...500	...500	...500
i	M_{2GN}	J_G	M_1	0.6	1.2	1.5	3.1	3.8
			n_1	4050	4050	4050	3750	4050
			I_{M230}	2.6	2.9	3.2	5	6.8
			I_{M400}	1.3	1.5	1.6	2.5	3.4
			P_N	0.25	0.51	0.64	1.2	1.6
			J_M	0.17	0.25	0.33	1.53	1.93
16	70	0.16	M_2		18	23	47	58
			c		3.9	3.1	1.5	1.2
			$n_{2 \text{ Eck}}$		253	253	234	253
			$n_{2 \text{ th}}$		219	219	219	219
20	70	0.14	M_2		23	29		
			c		3.1	2.5		
			$n_{2 \text{ Eck}}$		203	203		
			$n_{2 \text{ th}}$		175	175		
28	70	0.12	M_2	16	32	40		
			c	4.4	2.2	1.8		
			$n_{2 \text{ Eck}}$	145	145	145		
			$n_{2 \text{ th}}$	136	136	136		

$M \dots$ [Nm]
 $n \dots$ [min^{-1}]
 $J \dots$ [kgcm^2]

$P \dots$ [kW]
 $I \dots$ [A]
 $i \dots$ [-]
 $c \dots$ [-]

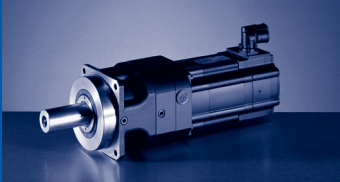

GPA [Nm]

GPA□□-□S (MCS)

$M_{2GN} \leq 170 \text{ Nm}$

GPA02-1S				09FN38	09HN41	12HN15	12HN35	12LN20	12LN41	14DN15	
				...500	...500	...500	...500	...500	...500	...500	
i	M_{2GN}	J_G	M_1	3.1	3.8	10	7.5	13.5	11	9.2	
			n_1	3750	4050	1500	3525	1950	4050	1500	
			I_{M230}	5	6.8	7.6		11.8			
			I_{M400}	2.5	3.4	3.8	5.7	5.9	10.2	4.5	
			P_N	1.2	1.6	1.6	2.8	2.8	4.7	1.45	
			J_M	1.53	1.93	7.42	7.42	10.72	10.72	8.22	
3	135	3.1	M_2							27	
			c							5	
			n_2 Eck								500
			n_2 th								500
4	0	2.25	M_2			38					
			c			4.3					
			n_2 Eck			375					
			n_2 th			0					
4	170	2.25	M_2					53	43	36	
			c					3.2	4	4.7	
			n_2 Eck					488	1013	375	
			n_2 th					488	625	375	
5	170	1.52	M_2			49	37	66	54	45	
			c			3.5	4.6	2.6	3.2	3.8	
			n_2 Eck			300	705	390	810	300	
			n_2 th			300	500	390	500	300	
7	170	1.69	M_2			68	51	92	75	63	
			c			2.5	3.3	1.9	2.3	2.7	
			n_2 Eck			214	504	279	579	214	
			n_2 th			214	400	279	400	214	
10	110	1.18	M_2	30	37						
			c	3.6	3						
			n_2 Eck	375	405						
			n_2 th	280	280						

M ... [Nm]
 n ... [min⁻¹]
 J ... [kgcm²]

P ... [kW]
 I ... [A]
 i [-]
 c [-]

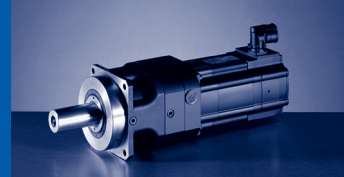

$M_{2GN} \leq 170 \text{ Nm}$

14DN36	14HN15	14HN32	14LN15	14LN32	14PN14	14PN32	GPA02-1S			
...500	...500	...500	...500	...500	...500	...500	M_1	J_G	M_{2GN}	i
7.5	16	14	23	17.2	30	21	n_1			
3600	1500	3225	1500	3225	1350	3225	I_{M230}			
							I_{M400}			
7.5	6.6	11.9	9.7	15	10.8	15.6	P_N			
2.8	2.5	4.7	3.6	5.8	4.2	7.1	J_M			
8.22	14.32	14.32	23.44	23.44	34.74	34.82	M_2			
	47	41	67	50	88	61	c	3.1	135	3
	2.9	3.3	2	2.7	1.5	2.2	$n_{2 \text{ Eck}}$			
	500	1075	500	1075	450	1075	$n_{2 \text{ th}}$			
	500	667	500	667	450	667	M_2			
							c	2.25	0	4
							$n_{2 \text{ Eck}}$			
							$n_{2 \text{ th}}$			
	62	55	90	67	117	82	M_2			
	2.7	3.1	1.9	2.5	1.5	2.1	c	2.25	170	4
	375	806	375	806	338	806	$n_{2 \text{ Eck}}$			
	375	625	375	625	338	625	$n_{2 \text{ th}}$			
37	78	68	112	84	146	102	M_2			
4.6	2.2	2.5	1.5	2	1.2	1.7	c	1.52	170	5
720	300	645	300	645	270	645	$n_{2 \text{ Eck}}$			
500	300	500	300	500	270	500	$n_{2 \text{ th}}$			
51	109	96	157	117		143	M_2			
3.3	1.6	1.8	1.1	1.5		1.2	c	1.69	170	7
514	214	461	214	461		461	$n_{2 \text{ Eck}}$			
400	214	400	214	400		400	$n_{2 \text{ th}}$			
							M_2			
							c	1.18	110	10
							$n_{2 \text{ Eck}}$			
							$n_{2 \text{ th}}$			

M ... [Nm]
n ... [min⁻¹]
J ... [kgcm²]

P ... [kW]
I ... [A]
i [-]
c [-]

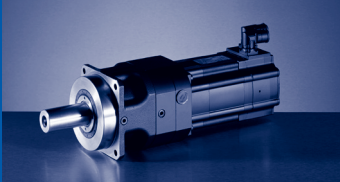

GPA [Nm]

GPA□□-□S (MCS)

$M_{2GN} \leq 170 \text{ Nm}$

GPA02-2S				09FN38	09HN41	12HN15	12HN35	12LN41
				...500	...500	...500	...500	...500
i	M_{2GN}	J_G	M_1	3.1	3.8	10	7.5	11
			n_1	3750	4050	1500	3525	4050
			I_{M230}	5	6.8	7.6		
			I_{M400}	2.5	3.4	3.8	5.7	10.2
			P_N	1.2	1.6	1.6	2.8	4.7
			J_M	1.53	1.93	7.42	7.42	10.72
16	170	0.58	M_2	47	58	152	114	167
			c	3.6	2.9	1.1	1.5	1
			$n_{2 \text{ Eck}}$	234	253	94	220	253
			$n_{2 \text{ th}}$	194	194	94	194	194
20	170	0.48	M_2	59	72			
			c	2.9	2.4			
			$n_{2 \text{ Eck}}$	188	203			
			$n_{2 \text{ th}}$	155	155			
28	170	0.41	M_2	83	101			
			c	2.1	1.7			
			$n_{2 \text{ Eck}}$	134	145			
			$n_{2 \text{ th}}$	125	125			
35	170	0.4	M_2	103	126			
			c	1.7	1.4			
			$n_{2 \text{ Eck}}$	107	116			
			$n_{2 \text{ th}}$	100	100			

M ... [Nm]
 n ... [min⁻¹]
 J ... [kgcm²]

P ... [kW]
 I ... [A]
 i [-]
 c [-]

GPA [Nm]
GPA□□-□S (MCS)

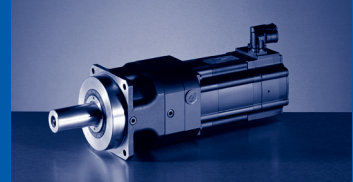

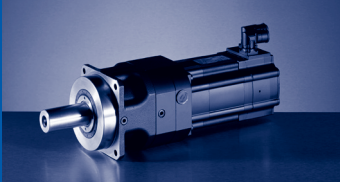

GPA [Nm]

GPA□□-□S (MCS)

$M_{2GN} \leq 360 \text{ Nm}$

GPA03-1S				12HN15	12HN35	12LN20	12LN41	14DN15	14DN36	14HN15	14HN32	14LN15
				...500	...500	...500	...500	...500	...500	...500	...500	...500
i	M_{2GN}	J_G	M_1	10	7.5	13.5	11	9.2	7.5	16	14	23
			n_1	1500	3525	1950	4050	1500	3600	1500	3225	1500
			I_{M230}	7.6		11.8						
			I_{M400}	3.8	5.7	5.9	10.2	4.5	7.5	6.6	11.9	9.7
			P_N	1.6	2.8	2.8	4.7	1.45	2.8	2.5	4.7	3.6
			J_M	7.42	7.42	10.72	10.72	8.22	8.22	14.32	14.32	23.44
3	290	9.31	M_2 c $n_{2 \text{ Eck}}$ $n_{2 \text{ th}}$									
4	360	6.89	M_2 c $n_{2 \text{ Eck}}$ $n_{2 \text{ th}}$									
5	360	5.97	M_2 c $n_{2 \text{ Eck}}$ $n_{2 \text{ th}}$									
7	360	3.9	M_2 c $n_{2 \text{ Eck}}$ $n_{2 \text{ th}}$							109 3.3 214 214	96 3.8 461 371	157 2.3 214 214
10	220	3.53	M_2 c $n_{2 \text{ Eck}}$ $n_{2 \text{ th}}$	98 2.3 150 150	73 3 353 260	132 1.7 195 195	107 2.1 405 260	90 2.5 150 150	73 3 360 260	156 1.4 150 150	137 1.6 323 260	224 1 150 150

M ... [Nm]
n ... [min^{-1}]
J ... [kgcm^2]

P ... [kW]
I ... [A]
i [-]
c [-]

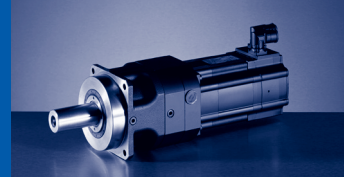

$M_{2GN} \leq 360 \text{ Nm}$

14LN32	14PN14	14PN32	19FN14	19FN30	19JN14	19JN30	19PN14	19PN30	GPA03-1S			
...500	...500	...500	...500	...500	...500	...500	...500	...500	M_1	J_G	M_{2GN}	i
17.2	30	21	27	21	40	29	51	32	n_1			
3225	1350	3225	1425	3000	1425	3000	1350	3000	i_{M230}			
									i_{M400}			
15	10.8	15.6	8.6	14	12.3	18.5	14.3	19	P_N			
5.8	4.2	7.1	4	6.6	6	9.1	7.2	10	J_M			
23.44	34.74	34.82	65.12	65.04	105.04	105.12	160.12	160.04	M_2			
			79	61	117	85	149	94	c			
			3.7	4.7	2.5	3.4	2	3.1	$n_{2 \text{ Eck}}$	9.31	290	3
			475	1000	475	1000	450	1000	$n_{2 \text{ th}}$			
			475	567	475	567	450	567	M_2			
			105	82	156	113	199	125	c	6.89	360	4
			3.4	4.4	2.3	3.2	1.8	2.9	$n_{2 \text{ Eck}}$			
			356	750	356	750	338	750	$n_{2 \text{ th}}$			
			356	525	356	525	338	525	M_2			
			132	102	195	141	249	156	c	5.97	360	5
			2.7	3.5	1.9	2.6	1.5	2.3	$n_{2 \text{ Eck}}$			
			285	600	285	600	270	600	$n_{2 \text{ th}}$			
			285	420	285	420	270	420	M_2			
117	205	143	184	143	273	198	348	218	c	3.9	360	7
3.1	1.8	2.5	2	2.5	1.3	1.8	1	1.7	$n_{2 \text{ Eck}}$			
461	193	461	204	429	204	429	193	429	$n_{2 \text{ th}}$			
371	193	371	204	371	204	371	193	371	M_2			
168		205							c	3.53	220	10
1.3		1.1							$n_{2 \text{ Eck}}$			
323		323							$n_{2 \text{ th}}$			
260		260										

M ... [Nm]
n ... [min⁻¹]
J ... [kgcm²]

P ... [kW]
I ... [A]
i [-]
c [-]

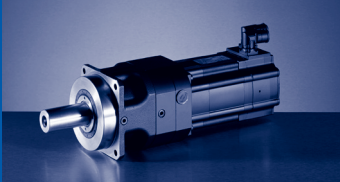

GPA [Nm]

GPA□□-□S (MCS)

$M_{2GN} \leq 360 \text{ Nm}$

GPA03-2S				12HN15	12HN35	12LN20	12LN41	14DN15	14DN36	14HN15	14HN32	14LN15	14LN32	14PN32	
				...S00	...S00	...S00	...S00	...S00	...S00	...S00	...S00	...S00	...S00	...S00	
i	M_{2GN}	J_G	M_1	10	7.5	13.5	11	9.2	7.5	16	14	23	17.2	21	
			n_1	1500	3525	1950	4050	1500	3600	1500	3225	1500	3225	3225	
			I_{M230}	7.6		11.8									
			I_{M400}	3.8	5.7	5.9	10.2	4.5	7.5	6.6	11.9	9.7	15	15.6	
			P_N	1.6	2.8	2.8	4.7	1.45	2.8	2.5	4.7	3.6	5.8	7.1	
			J_M	7.42	7.42	10.72	10.72	8.22	8.22	14.32	14.32	23.44	23.44	34.82	
16	360	2.37	M_2	152	114	205	167	140	114	243	213	350	261	319	
			c	2.4	3.2	1.8	2.2	2.6	3.2	1.5	1.7	1	1.4	1.1	
			$n_{2 \text{ Eck}}$	94	220	122	253	94	225	94	202	94	202	202	202
			$n_{2 \text{ th}}$	94	181	122	181	94	181	94	181	94	181	181	181
20	360	2.02	M_2	190	143	257	209	175	143	304	266		327		
			c	1.9	2.5	1.4	1.7	2.1	2.5	1.2	1.4		1.1		
			$n_{2 \text{ Eck}}$	75	176	98	203	75	180	75	161		161		
			$n_{2 \text{ th}}$	75	145	98	145	75	145	75	145		145		
28	360	1.74	M_2	266	200	359	293								
			c	1.4	1.8	1	1.2								
			$n_{2 \text{ Eck}}$	54	126	70	145								
			$n_{2 \text{ th}}$	54	114	70	114								

M ... [Nm]
 n ... [min⁻¹]
 J ... [kgcm²]

P ... [kW]
 I ... [A]
 i [-]
 c [-]

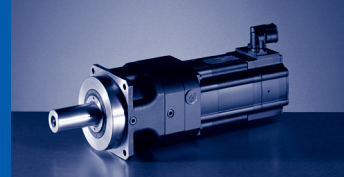

$M_{2GN} \leq 620 \text{ Nm}$

GPA04-1S				19FN14	19FN30	19JN14	19JN30	19PN14	19PN30
				...500	...500	...500	...500	...500	...500
i	M_{2GN}	J_G	M_1	27	21	40	29	51	32
			n_1	1425	3000	1425	3000	1350	3000
			I_{M400}	8.6	14	12.3	18.5	14.3	19
			P_N	4	6.6	6	9.1	7.2	10
			J_M	65.12	65.04	105.04	105.12	160.12	160.04
5	550	19.46	M_2	132		195	141	249	156
			c	4.2		2.8	3.9	2.2	3.5
			$n_{2 \text{ Eck}}$	285		285	600	270	600
			$n_{2 \text{ th}}$	285		285	340	270	340
7	550	25.9	M_2	184	143	273	198	348	218
			c	3	3.8	2	2.8	1.6	2.5
			$n_{2 \text{ Eck}}$	204	429	204	429	193	429
			$n_{2 \text{ th}}$	204	343	204	343	193	343
10	340	24.89	M_2	263	205				312
			c	1.3	1.7				1.1
			$n_{2 \text{ Eck}}$	143	300				300
			$n_{2 \text{ th}}$	143	240				240
10	360	24.89	M_2				283		
			c				1.3		
			$n_{2 \text{ Eck}}$				300		
			$n_{2 \text{ th}}$				240		

GPA04-2S				19FN14	19FN30	19JN14	19JN30	19PN30
				...500	...500	...500	...500	...500
i	M_{2GN}	J_G	M_1	27	21	40	29	32
			n_1	1425	3000	1425	3000	3000
			I_{M400}	8.6	14	12.3	18.5	19
			P_N	4	6.6	6	9.1	10
			J_M	65.12	65.04	105.04	105.12	160.04
16	550	7.33	M_2			550		
			c			1		
			$n_{2 \text{ Eck}}$			89		
			$n_{2 \text{ th}}$			89		
16	620	7.33	M_2	410	319		441	486
			c	1.5	1.9		1.4	1.3
			$n_{2 \text{ Eck}}$	89	188		188	188
			$n_{2 \text{ th}}$	89	169		169	169

$M \dots$ [Nm]
 $n \dots$ [min^{-1}]
 $J \dots$ [kgcm^2]

$P \dots$ [kW]
 $I \dots$ [A]
 i [-]
 c [-]

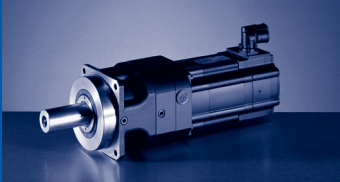

GPA [Nm]

GPA□□-□S (MCS)

$M_{2GN} \leq 1000 \text{ Nm}$

GPA05-1S				19FN14	19FN30	19JN14	19JN30	19PN14	19PN30
				...500	...500	...500	...500	...500	...500
i	M_{2GN}	J_G	M_1	27	21	40	29	51	32
			n_1	1425	3000	1425	3000	1350	3000
			I_{M400}	8.6	14	12.3	18.5	14.3	19
			P_N	4	6.6	6	9.1	7.2	10
			J_M	65.12	65.04	105.04	105.12	160.12	160.04
7	1000	21.36	M_2			273		348	
			c			3.7		2.9	
			$n_{2 \text{ Eck}}$			204		193	
			$n_{2 \text{ th}}$			204		193	
10	620	18.62	M_2	263	205	390	283	497	312
			c	2.4	3	1.6	2.2	1.3	2
			$n_{2 \text{ Eck}}$	143	300	143	300	135	300
			$n_{2 \text{ th}}$	143	220	143	220	135	220

GPA05-2S				19FN14	19FN30	19JN14	19JN30	19PN14	19PN30
				...500	...500	...500	...500	...500	...500
i	M_{2GN}	J_G	M_1	27	21	40	29	51	32
			n_1	1425	3000	1425	3000	1350	3000
			I_{M400}	8.6	14	12.3	18.5	14.3	19
			P_N	4	6.6	6	9.1	7.2	10
			J_M	65.12	65.04	105.04	105.12	160.12	160.04
16	1000	23.39	M_2	410	319	608	441	775	486
			c	2.4	3.1	1.6	2.3	1.3	2.1
			$n_{2 \text{ Eck}}$	89	188	89	188	84	188
			$n_{2 \text{ th}}$	89	156	89	156	84	156
20	1000	20.08	M_2	513	399	760	551	969	608
			c	2	2.5	1.3	1.8	1	1.6
			$n_{2 \text{ Eck}}$	71	150	71	150	68	150
			$n_{2 \text{ th}}$	71	125	71	125	68	125
28	1000	26.22	M_2	718	559	1000	771		851
			c	1.4	1.8	1	1.3		1.2
			$n_{2 \text{ Eck}}$	51	107	51	107		107
			$n_{2 \text{ th}}$	51	89	51	89		89

$M \dots [\text{Nm}]$
 $n \dots [\text{min}^{-1}]$
 $J \dots [\text{kgcm}^2]$

$P \dots [\text{kW}]$
 $I \dots [\text{A}]$
 $i \dots [-]$
 $c \dots [-]$

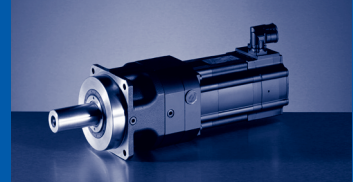

$M_{2GN} \leq 25 \text{ Nm}$

GPA00-1A				10IN40
				...500
i	M_{2GN}	J_G	M_1	
			n_1	2
			I_{M400}	3950
			P_N	2.4
			J_M	0.8
			M_2	2.44
4	25	0.16	c	8
			$n_{2 \text{ Eck}}$	3.2
			$n_{2 \text{ th}}$	988
				825
5	25	0.13	M_2	10
			c	2.6
			$n_{2 \text{ Eck}}$	790
			$n_{2 \text{ th}}$	660

M ... [Nm]
n ... [min^{-1}]
J ... [kgcm^2]

P ... [kW]
I ... [A]
i [-]
c [-]

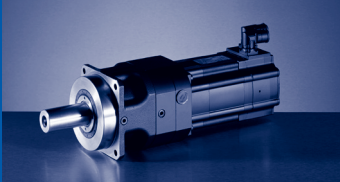

GPA [Nm]

GPA□□-□A (MCA)

$M_{2GN} \leq 72 \text{ Nm}$

GPA01-1A				10IN40	13IN34	13IN41
				...500	...F10	...500
i	M_{2GN}	J_G	M_1	2	6.3	4
			n_1	3950	3410	4050
			I_{M400}	2.4	6	4.4
			P_N	0.8	2.2	1.7
			J_M	2.44	8.34	8.34
3	56	0.71	M_2		18	11
			c		3	4.8
			$n_{2 \text{ Eck}}$		1137	1350
			$n_{2 \text{ th}}$		767	767
4	70	0.52	M_2		24	15
			c		2.8	4.5
			$n_{2 \text{ Eck}}$		853	1013
			$n_{2 \text{ th}}$		725	725
7	70	0.39	M_2		43	27
			c		1.6	2.6
			$n_{2 \text{ Eck}}$		487	579
			$n_{2 \text{ th}}$		443	443
7	72	0.39	M_2	13		
			c	5.3		
			$n_{2 \text{ Eck}}$	564		
			$n_{2 \text{ th}}$	443		
10	46	0.36	M_2	19		
			c	2.4		
			$n_{2 \text{ Eck}}$	395		
			$n_{2 \text{ th}}$	310		

GPA01-2A				10IN40
				...500
i	M_{2GN}	J_G	M_1	2
			n_1	3950
			I_{M400}	2.4
			P_N	0.8
			J_M	2.44
16	70	0.16	M_2	30
			c	2.3
			$n_{2 \text{ Eck}}$	247
			$n_{2 \text{ th}}$	219

$M \dots$ [Nm]
 $n \dots$ [min^{-1}]
 $J \dots$ [kgcm^2]

$P \dots$ [kW]
 $I \dots$ [A]
 $i \dots$ [-]
 $c \dots$ [-]

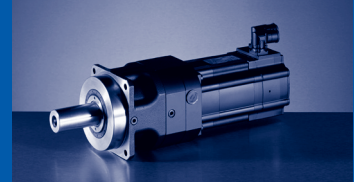

$M_{2GN} \leq 170 \text{ Nm}$

GPA02-1A				10IN40	13IN34	14LN16	14LN20	14LN35	14LN41	17NN17	17NN23	17NN35	17NN41
				...S00	...F10	...F10	...S00	...F10	...S00	...F10	...S00	...F10	...S00
i	M_{2GN}	J_G	M_1	2	6.3	12	6.7	10.8	5.4	21.5	10.8	19	9.5
			n_1	3950	3410	1635	2000	3455	4100	1680	2300	3480	4110
			I_{M400}	2.4	6	4.8	3.3	9.1	5.8	8.5	5.5	15.8	10.2
			P_N	0.8	2.2	2.1	1.4	3.9	2.3	3.8	2.6	6.9	4.1
			J_M	2.44	8.34	19.32	19.24	19.24	19.24	36.04	36.04	36.04	36.04
3	135	3.1	M_2			34		31		62	31	55	27
			c			3.8		4.3		2.1	4.3	2.4	4.8
			$n_{2 \text{ Eck}}$			545		1152		560	767	1160	1370
			$n_{2 \text{ th}}$			545		667		560	667	667	667
4	170	2.25	M_2			46		41		83	41	74	36
			c			3.6		4		2	4	2.3	4.6
			$n_{2 \text{ Eck}}$			409		864		420	575	870	1028
			$n_{2 \text{ th}}$			409		625		420	575	625	625
5	170	1.52	M_2		29	58	31	52		105	52	92	45
			c		5.5	2.9	5.2	3.2	1.6	3.2	1.8	3.7	
			$n_{2 \text{ Eck}}$		682	327	400	691	336	460	696	822	
			$n_{2 \text{ th}}$		500	327	400	500	336	460	500	500	
7	170	1.69	M_2		42	81	45	73	36	147	73	130	64
			c		3.9	2.1	3.7	2.3	4.6	1.2	2.3	1.3	2.6
			$n_{2 \text{ Eck}}$		487	234	286	494	586	240	329	497	587
			$n_{2 \text{ th}}$		400	234	286	400	400	240	329	400	400
10	110	1.18	M_2	19									
			c	5.6									
			$n_{2 \text{ Eck}}$	395									
			$n_{2 \text{ th}}$	280									

GPA02-2A				10IN40	13IN34	13IN41
				...S00	...F10	...S00
i	M_{2GN}	J_G	M_1	2	6.3	4
			n_1	3950	3410	4050
			I_{M400}	2.4	6	4.4
			P_N	0.8	2.2	1.7
			J_M	2.44	8.34	8.34
16	170	0.58	M_2	29	96	60
			c	5.5	1.8	2.8
			$n_{2 \text{ Eck}}$	247	213	253
			$n_{2 \text{ th}}$	194	194	194
20	170	0.48	M_2	37		
			c	4.4		
			$n_{2 \text{ Eck}}$	198		
			$n_{2 \text{ th}}$	155		
28	170	0.41	M_2	53		
			c	3.2		
			$n_{2 \text{ Eck}}$	141		
			$n_{2 \text{ th}}$	125		
35	170	0.4	M_2	66		
			c	2.5		
			$n_{2 \text{ Eck}}$	113		
			$n_{2 \text{ th}}$	100		

$M \dots$ [Nm]
 $n \dots$ [min^{-1}]
 $J \dots$ [kgcm^2]

$P \dots$ [kW]
 $I \dots$ [A]
 $i \dots$ [-]
 $c \dots$ [-]

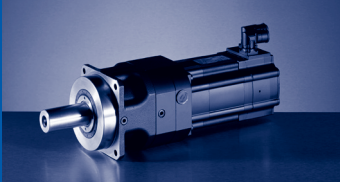

GPA [Nm]

GPA□□-□A (MCA)

$M_{2GN} \leq 360 \text{ Nm}$

GPA03-1A				13IN34	13IN41	14LN16	14LN20	14LN35	14LN41	17NN17	17NN23	17NN35
				...F10	...S00	...F10	...S00	...F10	...S00	...F10	...S00	...F10
i	M_{2GN}	J_G	M_1	6.3	4	12	6.7	10.8	5.4	21.5	10.8	19
			n_1	3410	4050	1635	2000	3455	4100	1680	2300	3480
			I_{M400}	6	4.4	4.8	3.3	9.1	5.8	8.5	5.5	15.8
			P_N	2.2	1.7	2.1	1.4	3.9	2.3	3.8	2.6	6.9
			J_M	8.34	8.34	19.32	19.24	19.24	19.24	36.04	36.04	36.04
3	290	9.31	M_2									
			c									
			$n_{2 \text{ Eck}}$ $n_{2 \text{ th}}$									
4	360	6.89	M_2									
			c									
			$n_{2 \text{ Eck}}$ $n_{2 \text{ th}}$									
5	360	5.97	M_2									
			c									
			$n_{2 \text{ Eck}}$ $n_{2 \text{ th}}$									
7	360	3.9	M_2			79		71		145	71	128
			c			4.4		4.9		2.4	4.9	2.8
			$n_{2 \text{ Eck}}$ $n_{2 \text{ th}}$			234 234		494 371		240 240	329 329	497 371
10	220	3.53	M_2	60	37	117	64	105	51	211	105	186
			c	3.6	5.6	1.9	3.4	2.1	4.2	1	2.1	1.2
			$n_{2 \text{ Eck}}$ $n_{2 \text{ th}}$	341 260	405 260	164 164	200 200	346 260	410 260	168 168	230 230	348 260

$M \dots$ [Nm]
 $n \dots$ [min^{-1}]
 $J \dots$ [kgcm^2]

$P \dots$ [kW]
 $I \dots$ [A]
 $i \dots$ [-]
 $c \dots$ [-]

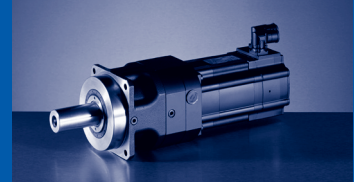

$M_{2GN} \leq 360 \text{ Nm}$

17NN41	195N17	195N23	195N35	195N42	21XN17	21XN25	21XN35	21XN42	GPA03-1A			
...S00	...F10	...S00	...F10	...S00	...F10	...S00	...F10	...S00	M_1	J_G	M_{2GN}	i
9.5	36.3	16.3	36	12	61.4	24.6	55	17	n_1			
4110	1700	2340	3510	4150	1710	2490	3520	4160	I_{M400}			
10.2	13.9	8.2	28.7	14	22.5	13.5	42.5	19.8	P_N			
4.1	6.4	4	13.2	5.2	11	6.4	20.3	7.4	J_M			
36.04	72.12	72.12	72.04	72.12	180.04	180.04	180.04	180.04	M_2			
	105		104		179	70	160	48	c	9.31	290	3
	2.7		2.7		1.6	4	1.8	5.8	$n_{2\text{ Eck}}$			
	567		1170		570	830	1173	1387	$n_{2\text{ th}}$			
	567		567		567	567	567	567				
	140	61	139						M_2	6.89	360	4
	2.5	5.6	2.6						c			
	425	585	878						$n_{2\text{ Eck}}$			
	425	525	525						$n_{2\text{ th}}$			
	176	77	175		300	118	269	80	M_2	5.97	360	5
	2	4.5	2		1.2	3	1.3	4.3	c			
	340	468	702		342	498	704	832	$n_{2\text{ Eck}}$			
	340	420	420		342	420	420	420	$n_{2\text{ th}}$			
62	248	109	246	79					M_2	3.9	360	7
5.5	1.5	3.2	1.5	4.4					c			
587	243	334	501	593					$n_{2\text{ Eck}}$			
371	243	334	371	371					$n_{2\text{ th}}$			
92									M_2	3.53	220	10
2.4									c			
411									$n_{2\text{ Eck}}$			
260									$n_{2\text{ th}}$			

M ... [Nm]
n ... [min⁻¹]
J ... [kgcm²]

P ... [kW]
I ... [A]
i [-]
c [-]

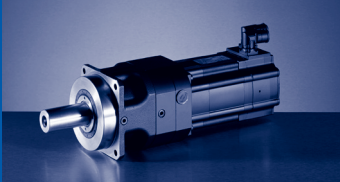

GPA [Nm]

GPA□□-□A (MCA)

$M_{2GN} \leq 360 \text{ Nm}$

GPA03-2A				13IN34	13IN41	14LN16	14LN20	14LN35	14LN41	17NN17	17NN23	17NN35	17NN41	
				...F10	...S00	...F10	...S00	...F10	...S00	...F10	...S00	...F10	...S00	
i	M_{2GN}	J_G	M_1	6.3	4	12	6.7	10.8	5.4	21.5	10.8	19	9.5	
			n_1	3410	4050	1635	2000	3455	4100	1680	2300	3480	4110	
			I_{M400}	6	4.4	4.8	3.3	9.1	5.8	8.5	5.5	15.8	10.2	
			P_N	2.2	1.7	2.1	1.4	3.9	2.3	3.8	2.6	6.9	4.1	
			J_M	8.34	8.34	19.32	19.24	19.24	19.24	36.04	36.04	36.04	36.04	
16	360	2.37	M_2	94	58	183	100	164	80	330	164	291	144	
			c	3.7	5.9	2	3.5	2.2	4.3	1.1	2.2	1.2	2.5	
			$n_{2 \text{ Eck}}$	213	253	102	125	216	256	105	144	218	257	
			$n_{2 \text{ th}}$	181	181	102	125	181	181	105	144	181	181	
20	360	2.02	M_2	119	74	229	126	206	101		206		181	
			c	3	4.7	1.6	2.8	1.7	3.5		1.7		2	
			$n_{2 \text{ Eck}}$	171	203	82	100	173	205		115		206	
			$n_{2 \text{ th}}$	145	145	82	100	145	145		115		145	
28	360	1.74	M_2	167	105									
			c	2.1	3.4									
			$n_{2 \text{ Eck}}$	122	145									
			$n_{2 \text{ th}}$	114	114									

M ... [Nm]
 n ... [min⁻¹]
 J ... [kgcm²]

P ... [kW]
 I ... [A]
 i [-]
 c [-]

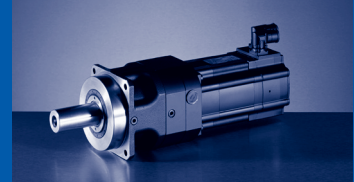

$M_{2GN} \leq 550 \text{ Nm}$

GPA04-1A				19SN17	19SN23	19SN35	19SN42	21XN17	21XN25	21XN35	21XN42
				...F10	...S00	...F10	...S00	...F10	...S00	...F10	...S00
i	M_{2GN}	J_G	M_1	36.3	16.3	36	12	61.4	24.6	55	17
			n_1	1700	2340	3510	4150	1710	2490	3520	4160
			I_{M400}	13.9	8.2	28.7	14	22.5	13.5	42.5	19.8
			P_N	6.4	4	13.2	5.2	11	6.4	20.3	7.4
			J_M	72.12	72.12	72.04	72.12	180.04	180.04	180.04	180.04
3	420	29.42	M_2					178	69	159	
			c					2.3	5.8	2.6	
			$n_{2 \text{ Eck}}$					570	830	1173	
			$n_{2 \text{ th}}$					467	467	467	
4	550	22.06	M_2					238	92	212	
			c					2.3	5.7	2.6	
			$n_{2 \text{ Eck}}$					428	623	880	
			$n_{2 \text{ th}}$					425	425	425	
5	550	19.46	M_2	174		173					
			c	3.1		3.1					
			$n_{2 \text{ Eck}}$	340		702					
			$n_{2 \text{ th}}$	340		340					
7	550	25.9	M_2	246	107	244		420	165	376	112
			c	2.2	4.9	2.2		1.3	3.3	1.5	4.7
			$n_{2 \text{ Eck}}$	243	334	501		244	356	503	594
			$n_{2 \text{ th}}$	243	334	343		244	343	343	343
10	340	24.89	M_2		158		115				
			c		2.1		2.9				
			$n_{2 \text{ Eck}}$		234		415				
			$n_{2 \text{ th}}$		234		240				

GPA04-2A				19SN23		19SN42	
				...S00		...S00	
i	M_{2GN}	J_G	M_1	16.3		12	
			n_1	2340		4150	
			I_{M400}	8.2		14	
			P_N	4		5.2	
			J_M	72.12		72.12	
16	550	7.33	M_2	247		181	
			c	2.2		3	
			$n_{2 \text{ Eck}}$	146		259	
			$n_{2 \text{ th}}$	146		169	

$M \dots$ [Nm]
 $n \dots$ [min^{-1}]
 $J \dots$ [kgcm^2]

$P \dots$ [kW]
 $I \dots$ [A]
 i [-]
 c [-]

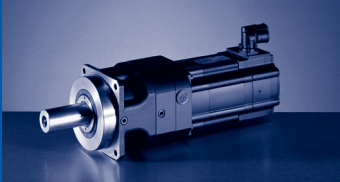

GPA [Nm]

GPA□□-□A (MCA)

$M_{2GN} \leq 1000 \text{ Nm}$

GPA05-1A				21XN17	21XN25	21XN35	21XN42
				...F10	...S00	...F10	...S00
i	M_{2GN}	J_G	M_1	61.4	24.6	55	17
			n_1	1710	2490	3520	4160
			I_{M400}	22.5	13.5	42.5	19.8
			P_N	11	6.4	20.3	7.4
			J_M	180.04	180.04	180.04	180.04
10	620	18.62	M_2	602	237	538	162
			c	1	2.6	1.2	3.7
			$n_{2 \text{ Eck}}$	171	249	352	416
			$n_{2 \text{ th}}$	171	220	220	220

GPA05-2A				21XN17	21XN25	21XN35	21XN42
				...F10	...S00	...F10	...S00
i	M_{2GN}	J_G	M_1	61.4	24.6	55	17
			n_1	1710	2490	3520	4160
			I_{M400}	22.5	13.5	42.5	19.8
			P_N	11	6.4	20.3	7.4
			J_M	180.04	180.04	180.04	180.04
16	1000	23.39	M_2	943	372	844	254
			c	1.1	2.7	1.2	3.8
			$n_{2 \text{ Eck}}$	107	156	220	260
			$n_{2 \text{ th}}$	107	156	156	156

$M \dots$ [Nm]
 $n \dots$ [min^{-1}]
 $J \dots$ [kgcm^2]

$P \dots$ [kW]
 $I \dots$ [A]
 $i [-]$
 $c [-]$

GPA [Nm]
GPA□□-□A (MCA)

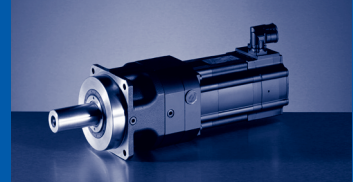

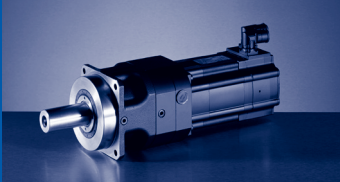

GPA [mm]

GPA□□-1S (MCS)

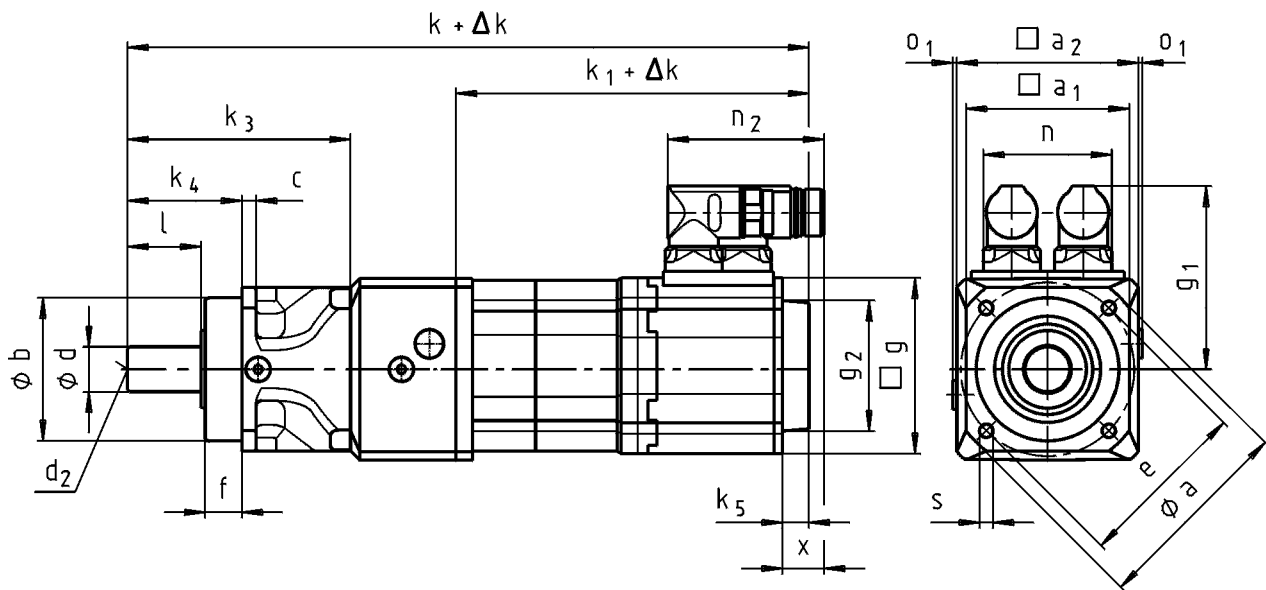

GPA□□-1S GCN ... RSO

		06C N41	06F N41	06I N41	09D N41	09F N38	09H N41	09L N41	12D N20	12D N41	12H N15	12H N30	12H N35	12L N20	12L N41	
GPA00...	a_2	65			89											
	k	265	295	325	316	336	356	396								
GPA01...	a_2	80			89							116				
	k		323	353	344	364	384	424	349		389		429			
GPA02...	a_2				102							116				
	k				392	412	432	472	397		437		477			
GPA03...	a_2											142				
	k								455		495		535			
...RSO B0 ¹⁾	Δk	0														
...RSO P□ ¹⁾	Δk	19			20											
	k_1	132	162	192	183	203	223	263	188		228		268			
	g	62			89				116							
...RSO	k_5	0			13				14							
	g_2	□ 62			Ø 67				Ø 72							
	g_1	76			90				105							
	n_2	64							78							
	n	58							63							
	x	21							18							

¹⁾ → 801 - SRS / SRM / ECN/ EQN / EQI / C20

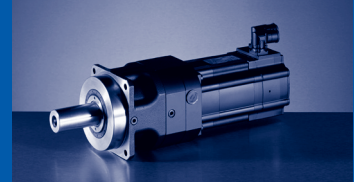

GPA□□-1S GCN ... RSO

		14D N15	14D N36	14H N15	14H N32	14L N15	14L N32	14P N14	14P N32	19F N14	19F N30	19J N14	19J N30	19P N14	19P N30	
GPA02...	a ₂	142														
	k	410		450			490		530							
GPA03...	a ₂	142														
	k	468		508			548		588	487		527		587		
GPA04...	a ₂	192														
	k							528		568		628				
GPA05...	a ₂	212														
	k							579		619		679				
...RSO B0 ¹⁾	Δ k	0														
...RSO P□ ¹⁾	Δ k	28						34			44					
	k ₁	201		241			281		321	220		260		320		
	g	143														
...RSO	k ₅	24									15					
	g ₂	Ø 78														
	g ₁	116					147	116	147	141	172	141	172	141	172	
	n ₂	78					94	78	94	78	94	78	94	78	94	
	n	63					80	63	80	63	80	63	80	63	80	
	x	16					38	16	38	16	36	16	36	16	36	

¹⁾ →  801 - SRS / SRM / ECN / EQN / EQI / C20

GPA□□-1S GCN

	k ₃			k ₄			o ₁			
GPA00...	94			48			2			
GPA01...	109			56						
GPA02...	146			88						
GPA03...	189			112			3			
GPA04...	213									
GPA05...	255			143						

	d	l	d ₂	a	a ₁	b	c	e	f	s
	k6					g6				4x90°
GPA00...	16	28	M5	80	65	60	6	68	18	5.5
GPA01...	22	36	M8	100	80	70	7	85		6.6
GPA02...	32	58	M12	140	102	90	10	120	28	9
GPA03...	40	82	M16	188	142	130	12	165		11
GPA04...	55		M20	250	182	160	15	215	27	13
GPA05...	75	105		290	212	180	17	250	35	17

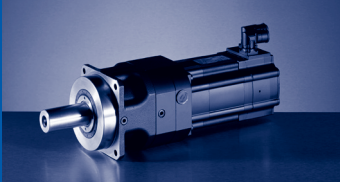

GPA [mm]

GPA□□-2S (MCS)

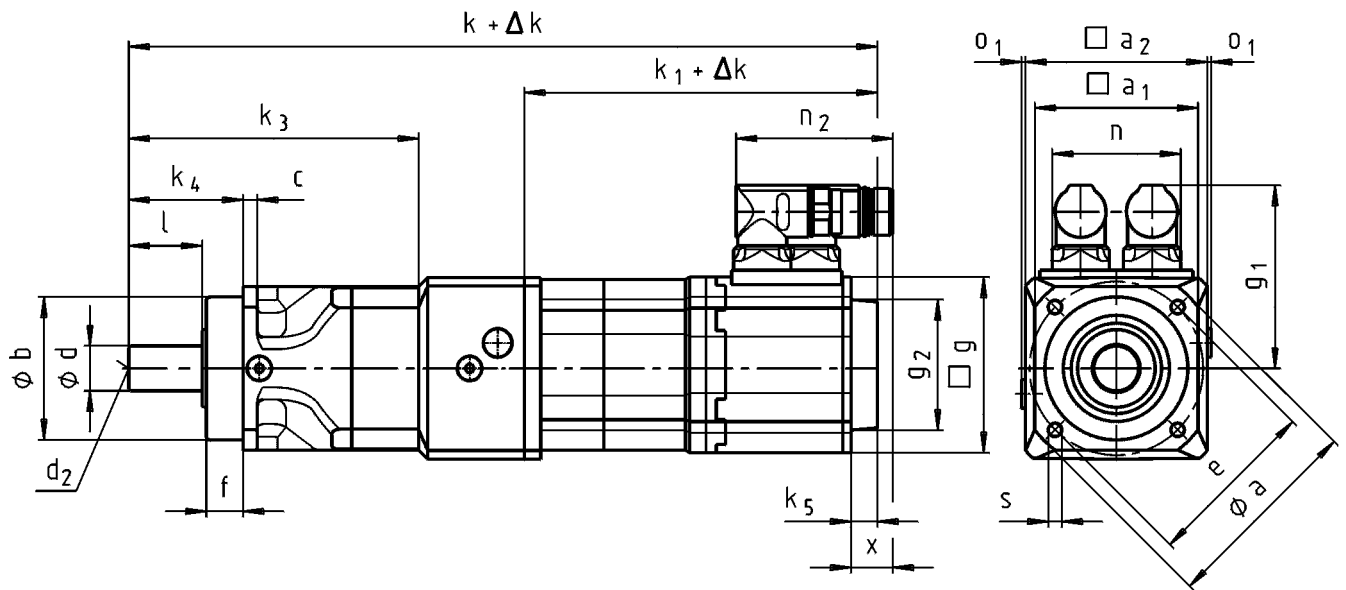

GPA□□-2S GCN ... RSO

		06C N41	06F N41	06I N41	09D N41	09F N38	09H N41	09L N41	12D N20	12D N41	12H N15	12H N30	12H N35	12L N20	12L N41	
GPA00...	a_2	65														
	k	296	326	356												
GPA01...	a_2	80			89											
	k	313	343	373	364	384	404	444								
GPA02...	a_2	102							116							
	k				419	439	459	499	424	464		504				
GPA03...	a_2								142							
	k								488	528		568				
...RSO B0 ¹⁾	Δk	0														
...RSO P□ ¹⁾	Δk	19			20											
...RSO	k_1	132	162	192	183	203	223	263	188	228		268				
	g	62			89				116							
...RSO	k_5	0			13				14							
	g_2	□ 62			Ø 67				Ø 72							
...RSO	g_1	76			90				105							
	n_2	64							78							
...RSO	n	58							63							
	x	21							18							

¹⁾ → 801 - SRS / SRM / ECN/ EQN / EQI / C20

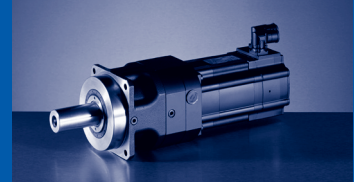

GPA□□-2S GCN ... RSO

		14D N15	14D N36	14H N15	14H N32	14L N15	14L N32	14P N32	19F N14	19F N30	19J N14	19J N30	19P N14	19P N30	
GPA03...	a ₂	142													
	k	501		541		581	621								
GPA04...	a ₂									192					
	k									558		598		658	
GPA05...	a ₂									212					
	k									648		688		748	
...RSO B0 ¹⁾	Δ k	0													
...RSO P□ ¹⁾	Δ k	28						34			44				
	k ₁	201		241		281	321	220		260		320			
	g	143						192							
...RSO	k ₅	24						15							
	g ₂	Ø 78													
	g ₁	116				147		141	172	141	172	141	172	141	172
	n ₂	78				94		78	94	78	94	78	94	78	94
	n	63				80		63	80	63	80	63	80	63	80
	x	16				38		16	36	16	36	16	36	16	36

1) → 801 - SRS / SRM / ECN / EQN / EQI / C20

GPA□□-2S GCN

	k ₃			k ₄			o ₁			
GPA00...	125			48			2			
GPA01...	142			56						
GPA02...	184			88						
GPA03...	237			112			3			
GPA04...	261			143						
GPA05...	334									

	d	l	d ₂	a	a ₁	b	c	e	f	s
	k6					g6				4x90°
GPA00...	16	28	M5	80	65	60	6	68	18	5.5
GPA01...	22	36	M8	100	80	70	7	85		6.6
GPA02...	32	58	M12	140	102	90	10	120	28	9
GPA03...	40	82	M16	188	142	130	12	165		11
GPA04...	55		M20	250	182	160	15	215	27	13
GPA05...	75	105		290	212	180	17	250	35	17

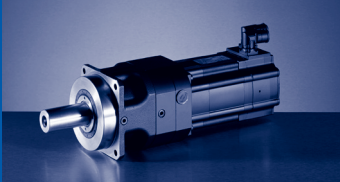

GPA [mm]

GPA□□-1A (MCA)

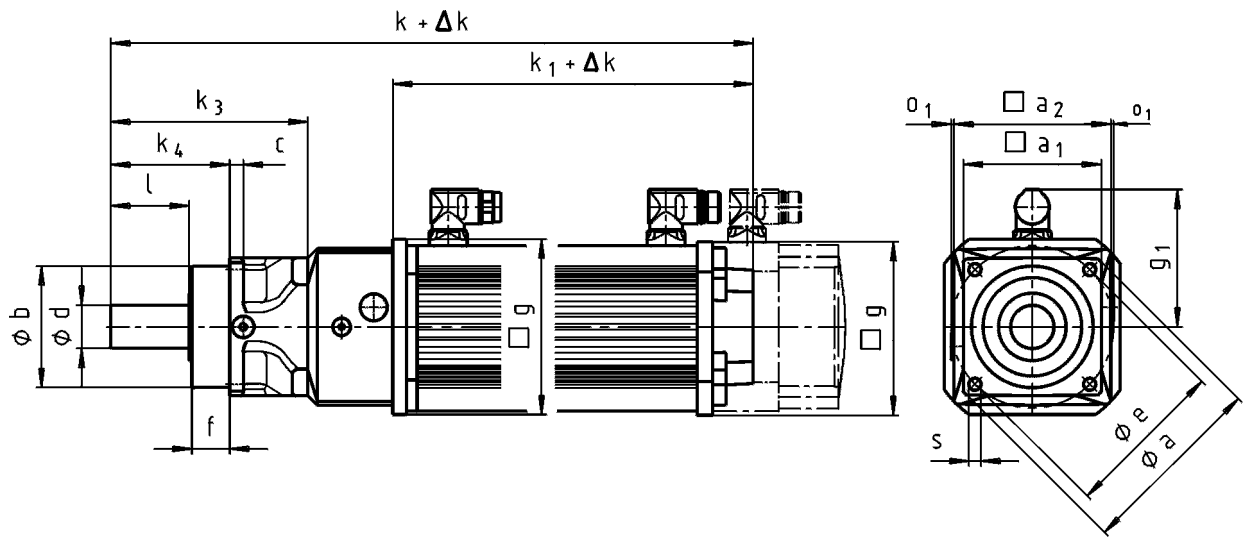

GPA□□-1A GCN ... RSO

		10I N40 ...S00	13I N41 ...S00	13I N34 ...F10	14L N20 ...S00	14L N41 ...S00	14L N16 ...F10	14L N35 ...F10	17N N23 ...S00	17N N41 ...S00
GPA00...	a_2	89								
	k	395								
GPA01...	a_2	89	116							
	k	423	432	500						
GPA02...	a_2	102	116				142			
	k	471	479	547	510		572		548	
GPA03...	a_2					142				
	k		537	605	568		630		606	
...RSO B0 ¹⁾	Δk					0				
...RSO P□ ¹⁾	Δk	25	35			33			35	
	k_1	262	271	339	302		364		340	
	g	102	131			142			165	
	g_1	90	102			109			118	

¹⁾ → 803 - SRS / SRM / ECN / EQN / EQI / S20 / T20 / CDD

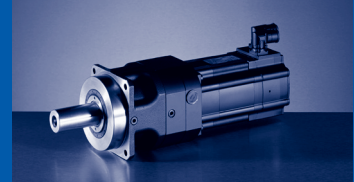

GPA□□-1A GCN ... RSO

		17N N17 ...F10	17N N35 ...F10	19S N23 ...S00	19S N42 ...S00	19S N17 ...F10	19S N35 ...F10	21X N25 ...S00	21X N42 ...S00	21X N17 ...F10	21X N35 ...F10
GPA02...	a ₂	142									
	k	637									
GPA03...	a ₂	142		192				214			
	k	695		668		765		756		852	
GPA04...	a ₂			192							
	k			709		806		777		873	
GPA05...	a ₂			212							
	k			760		857		829		925	
...RSO B0 ¹⁾	Δ k	0									
...RSO P□ ¹⁾	Δ k	35		38				42			
	k ₁	429		401		498		470		566	
	g	165		192				214			
	g ₁	118		161				172			

¹⁾ →  803 - SRS / SRM / ECN / EQN / EQI / S20 / T20 / CDD

GPA□□-1A GCN

	k ₃			k ₄			o ₁			
GPA00...	94			48			2			
GPA01...	109			56						
GPA02...	146			88						
GPA03...	189			112			3			
GPA04...	213									
GPA05...	255			143						

	d	l	d ₂	a	a ₁	b	c	e	f	s
	k6					g6				4x90°
GPA00...	16	28	M5	80	65	60	6	68	18	5.5
GPA01...	22	36	M8	100	80	70	7	85		6.6
GPA02...	32	58	M12	140	102	90	10	120	28	9
GPA03...	40	82	M16	188	142	130	12	165		11
GPA04...	55		M20	250	182	160	15	215	27	13
GPA05...	75	105	M20	290	212	180	17	250	35	17

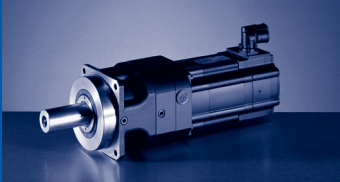

GPA [mm]

GPA□□-2A (MCA)

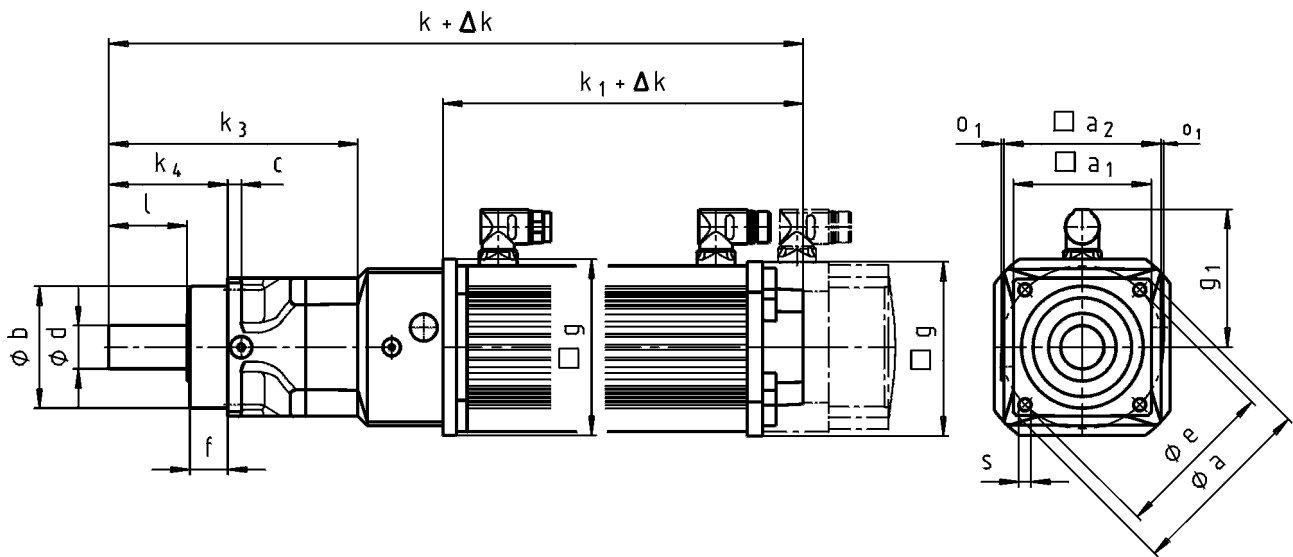

GPA□□-2A GCN ... RSO

		10I N40 ...S00	13I N41 ...S00	13I N34 ...F10	14L N20 ...S00	14L N41 ...S00	14L N16 ...F10	14L N35 ...F10	17N N23 ...S00	17N N41 ...S00
GPA01...	a_2	89								
	k	443								
GPA02...	a_2	102	116							
	k	498	507	575						
GPA03...	a_2					142				
	k		571	639	602		664		640	
...RSO B0 ¹⁾	Δk	0								
...RSO P□ ¹⁾	Δk	25	35		33				35	
	k_1	262	271	339	302		364		340	
	g	102	131		142				165	
	g_1	90	102		109				118	

¹⁾ → 803 - SRS / SRM / ECN / EQN / EQI / S20 / T20 / CDD

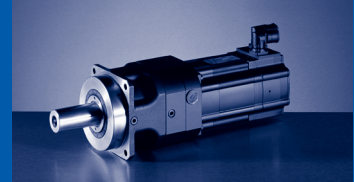

GPA□□-2A GCN ... RSO

		17N N17 ...F10	17N N35 ...F10	19S N23 ...S00	19S N42 ...S00	19S N17 ...F10	19S N35 ...F10	21X N25 ...S00	21X N42 ...S00	21X N17 ...F10	21X N35 ...F10
GPA03...	a ₂	142									
	k	729									
GPA04...	a ₂			192							
	k			739	836						
GPA05...	a ₂					212					
	k			829	926		898		994		
...RSO B0 ¹⁾	Δ k			0							
...RSO P□ ¹⁾	Δ k	35		38				42			
	k ₁	429		401		498		470		566	
	g	165				192				214	
	g ₁	118				161				172	

¹⁾ →  803 - SRS / SRM / ECN / EQN / EQI / S20 / T20 / CDD

GPA□□-2A GCN

	k ₃			k ₄			o ₁			
GPA01...	142			56			2			
GPA02...	184			88						
GPA03...	237			112			3			
GPA04...	261									
GPA05...	334			143						

	d	l	d ₂	a	a ₁	b	c	e	f	s
	k6					g6				4x90°
GPA01...	22	36	M8	100	80	70	7	85	18	6.6
GPA02...	32	58	M12	140	102	90	10	120	28	9
GPA03...	40	82	M16	188	142	130	12	165		11
GPA04...	55		M20	250	182	160	15	215	27	13
GPA05...	75	105		290	212	180	17	250	35	17

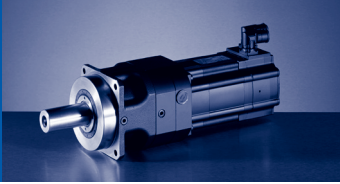

GPA [mm]
GPA□□-2A (MCA)

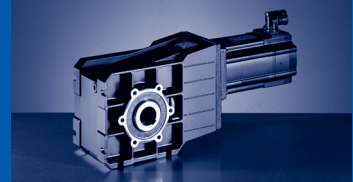

Permissible radial force

$$Fr_{zul} = \min(f_w \times f_{\alpha} \times Fr_{Tab}; f_w \times Fr_{max})$$

Permissible axial force

$$Fa_{zul} = Fa_{Tab} \text{ at } Fr = 0$$

At Fr and $Fa \neq 0$ please contact your Lenze sales office.

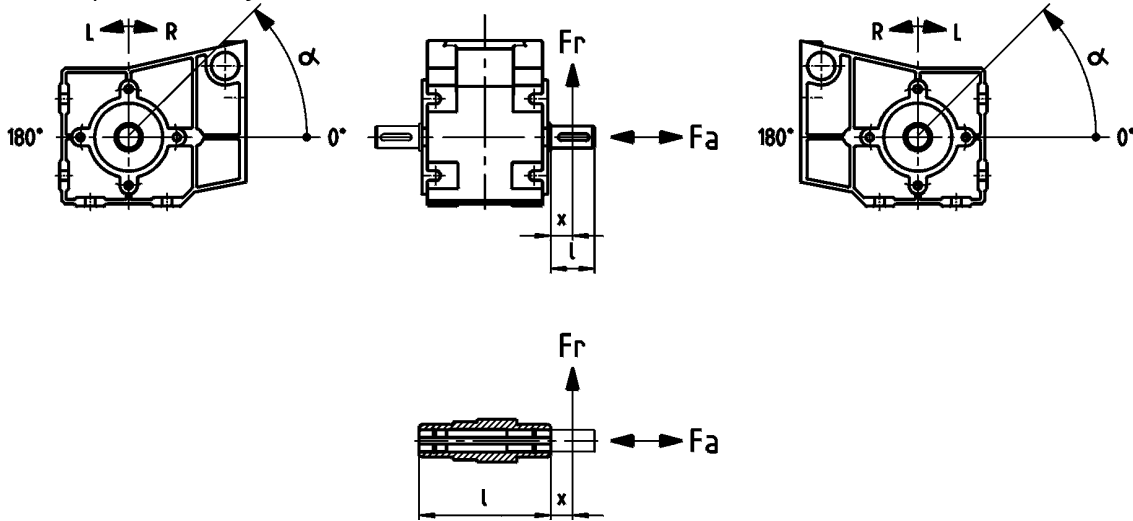

Effective direction factor f_{α} at output shaft

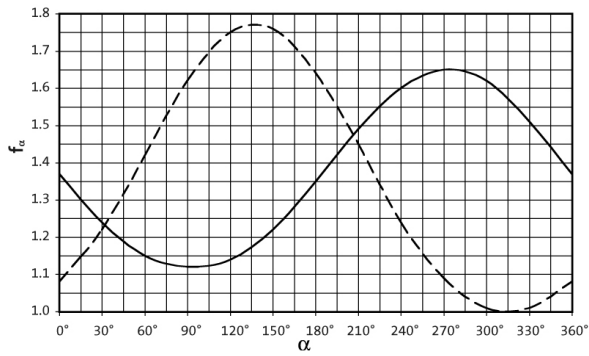

Additional load factor f_w at output shaft

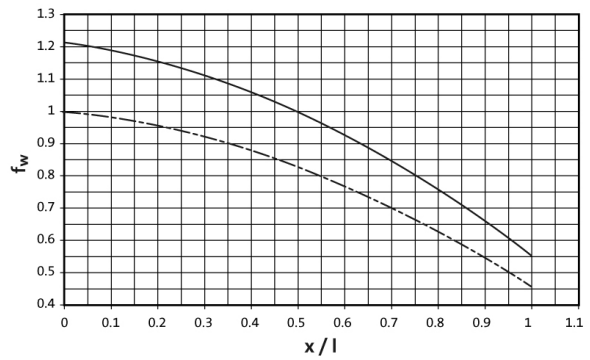

— Direction of rotation R
 - - - Direction of rotation L

— Solid shaft (V□□)
 - - - Hollow shaft (H□□)

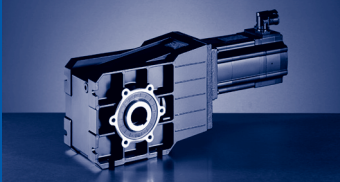

GKR [N]

Solid shaft without flange (V□R)								
Application of force Fr: centre of shaft journal (x = l/2)								
Fa _{Tab} only valid for Fr = 0								
	GKR03-2		GKR04-2		GKR05-2		GKR06-2	
n ₂ [min ⁻¹]	Fr _{Tab} [N]	Fa _{Tab} [N]	Fr _{Tab} [N]	Fa _{Tab} [N]	Fr _{Tab} [N]	Fa _{Tab} [N]	Fr _{Tab} [N]	Fa _{Tab} [N]
1000	900	600	1000	700	1500	1100	2000	1500
630	1200	800	1800	1000	2350	1520	2800	2000
400	1800	1000	2100	1275	3000	1900	4000	2500
250	2100	1100	2500	1500	3600	2200	4200	2600
160	2400	1250	2700	1650	4500	2500	4500	2750
100	2800	1400	3000	1800	5000	3100	5600	3500
63	3000	1400	3000	1800	6000	3700	7300	4500
40	3000	1400	3000	1800	6500	3900	8600	5000
25	3000	1400	3000	1800	6500	3900	9000	5000
≤ 16	3000	1400	3000	1800	6500	3900	9000	5000
Fr _{max}	3000	-	3000	-	6500	-	9000	-

Solid shaft with flange (V□K)								
Application of force Fr: centre of shaft journal (x = l/2)								
Fa _{Tab} only valid for Fr = 0								
	GKR03-2		GKR04-2		GKR05-2		GKR06-2	
n ₂ [min ⁻¹]	Fr _{Tab} [N]	Fa _{Tab} [N]	Fr _{Tab} [N]	Fa _{Tab} [N]	Fr _{Tab} [N]	Fa _{Tab} [N]	Fr _{Tab} [N]	Fa _{Tab} [N]
1000	900	600	1000	700	2400	1100	3000	1500
630	1200	800	1800	1000	3600	1500	4000	2000
400	1800	1000	2100	1275	5200	1900	5500	2500
250	2100	1100	2500	1500	6000	2200	6200	2600
160	2400	1250	2700	1650	6500	2500	7000	2750
100	2800	1400	3000	1800	6500	3100	9000	3500
63	3000	1400	3000	1800	6500	3700	9000	4500
40	3000	1400	3000	1800	6500	3900	9000	5000
25	3000	1400	3000	1800	6500	3900	9000	5000
≤ 16	3000	1400	3000	1800	6500	3900	9000	5000
Fr _{max}	3000	-	3000	-	6500	-	9000	-

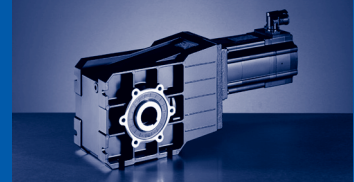

Hollow shaft (H□□)								
Application of force Fr: on hollow shaft end face (x = 0)								
Fa _{Tab} only valid for Fr = 0								
	GKR03-2		GKR04-2		GKR05-2		GKR06-2	
n ₂ [min ⁻¹]	Fr _{Tab} [N]	Fa _{Tab} [N]	Fr _{Tab} [N]	Fa _{Tab} [N]	Fr _{Tab} [N]	Fa _{Tab} [N]	Fr _{Tab} [N]	Fa _{Tab} [N]
1000	900	600	1000	700	1500	1100	3000	1500
630	1200	800	2200	1000	2250	1500	3800	2000
400	2200	1000	2550	1275	3800	1900	5000	2500
250	2500	1100	3000	1500	4500	2200	5200	2600
160	2800	1250	3300	1650	5100	2500	5500	2750
100	3000	1400	3600	1800	6200	3100	7000	3500
63	3000	1400	3600	1800	7400	3700	9000	4500
40	3000	1400	3600	1800	7800	3900	10000	5000
25	3000	1400	3600	1800	7800	3900	10000	5000
≤ 16	3000	1400	3600	1800	7800	3900	10000	5000
Fr_{max}	3000	-	3600	-	7800	-	10000	-

- ▶ Neither radial nor axial forces are permissible for the hollow shaft with shrink disc (S□□).

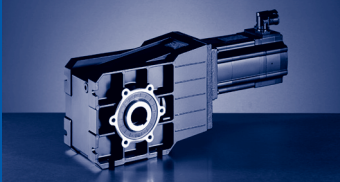

Output backlash in angular minutes

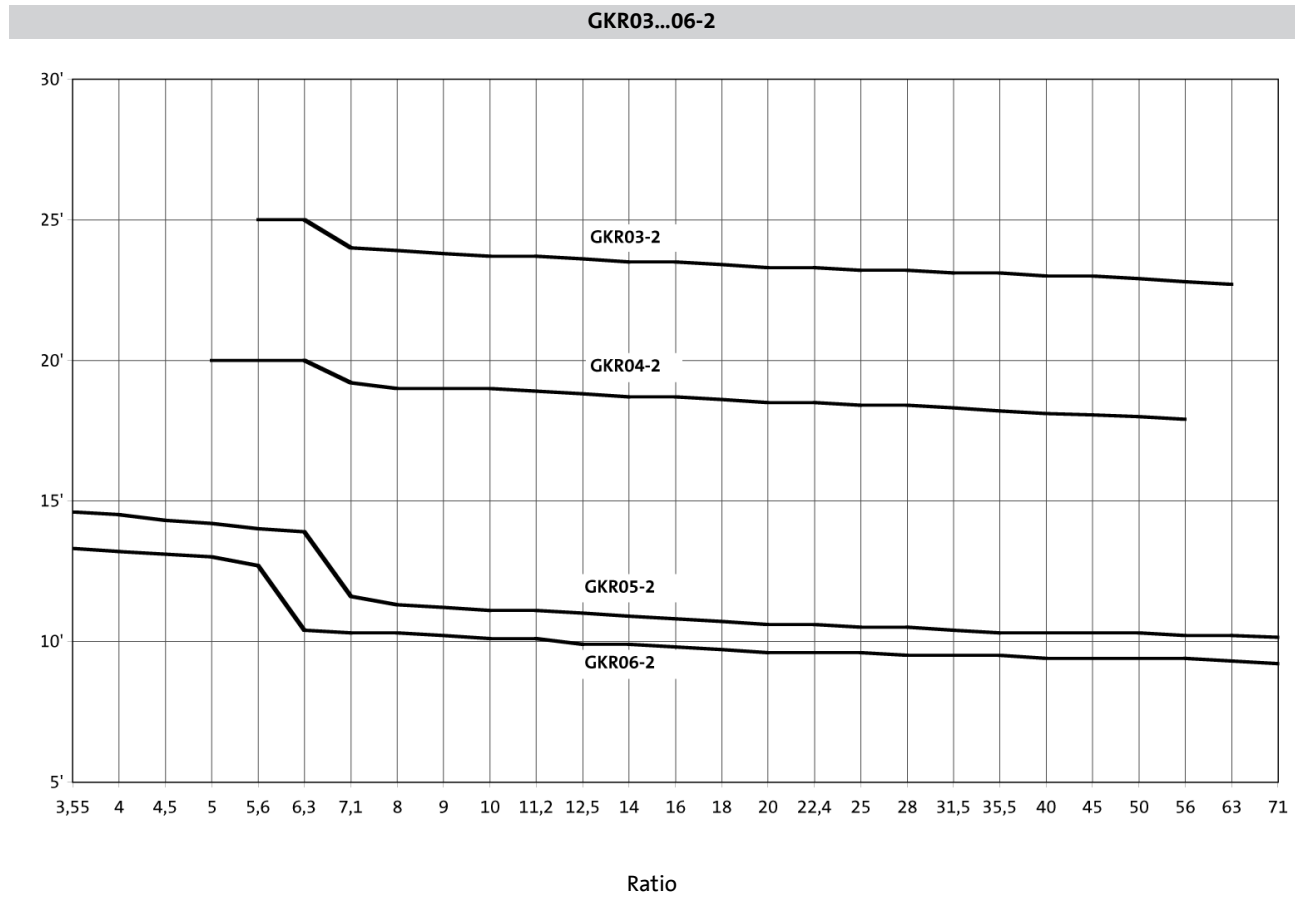

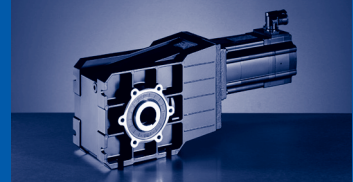

Position of ventilation

GKR06

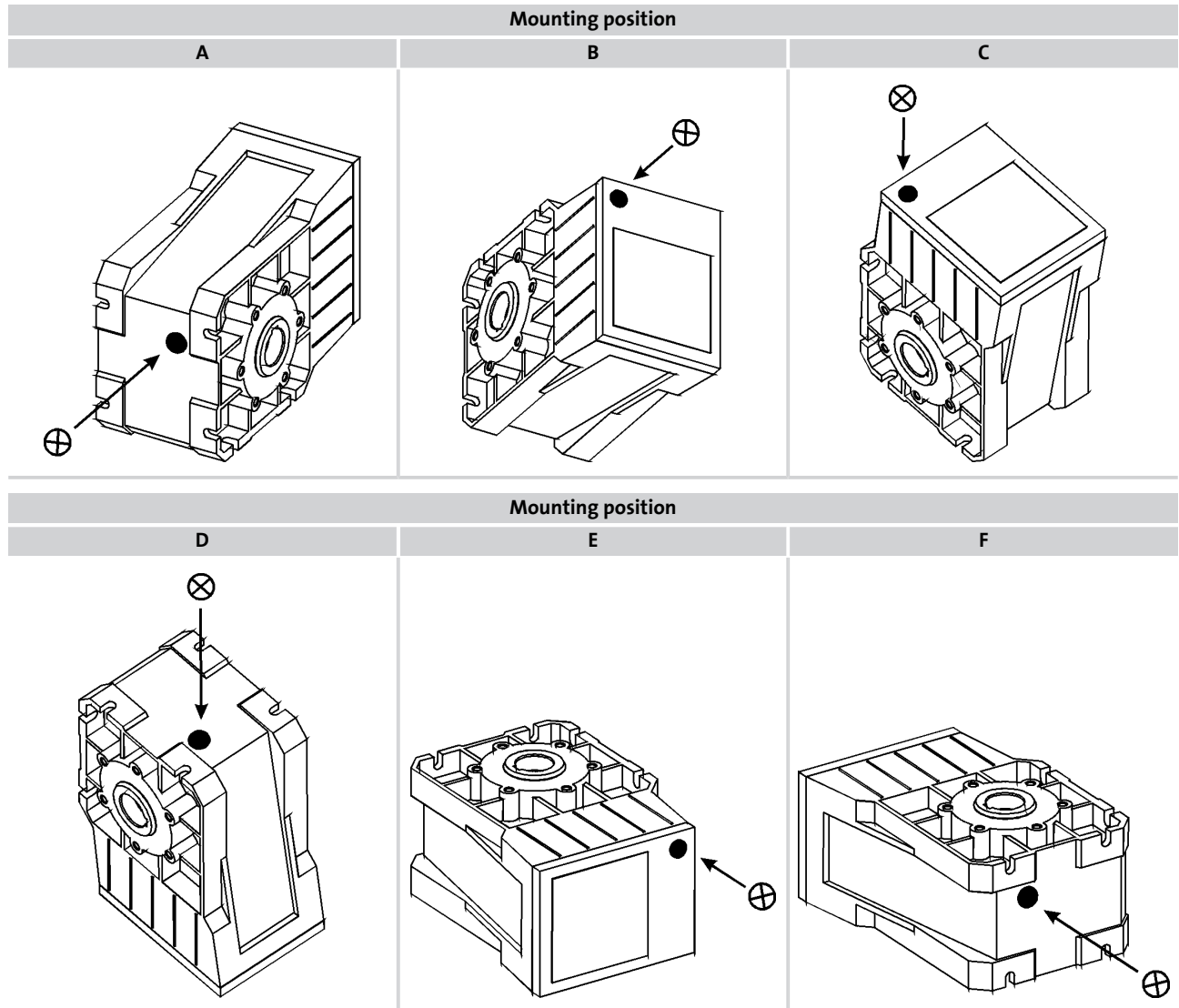

⊗ Ventilation

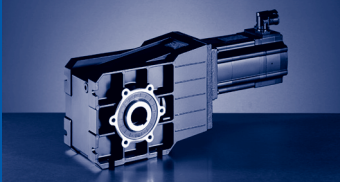

GKR [kg]

GKR□□-2S HAR/HBR...RSO B0

	06C C41	06F C41	06I C41	09D C41	09F C38	09H C41	09L C41	12D C20	12D C41	12H C15	12H C30	12H C35	12L C20	12L C41
GKR03...	5	6	7											
GKR04...	7	8		10	11	12	14							
GKR05...	10	11	12	13	14	15		17			20			23
GKR06...	19	20		22	23	24	26	25			28			31
	14D C15	14D C36	14H C15	14H C32	14L C15	14L C32	14L C15	14L C32	14P C14	14P C32				
GKR06...	30			35			39			44				

GKR□□-2A HAR/HBR...RSO B0

	10I C40 ...S00	13I C41 ...S00	13I C34 ...F10	14L C20 ...S00	14L C41 ...S00	14L C16 ...F10	14L C35 ...F10	17N C23 ...S00	17N C41 ...S00	17N C17 ...F10	17N C35 ...F10
GKR04...	11	16	17								
GKR05...	16	20	21	26		27					
GKR06...	24	28	29	34		36		42		44	

Note additional weights.

Weights in [kg] with oil capacity for mounting position A, all given as approximate values

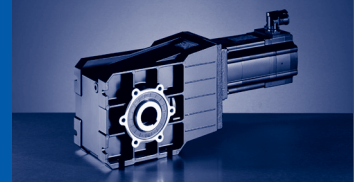

Additional weights MCS servo motors

	06C C41	06F C41	06I C41	09D C41	09F C38	09H C41	09L C41	12D C20	12D C41	12H C15	12H C30	12H C35	12L C20	12L C41
...P1	0.3			0.8			0.9							
...P2				0.5			1.2							
...SCS/SCM/SRM/SRS ...ECN/EQN	0.4			0.2			0.3							

	14D C15	14D C36	14H C15	14H C32	14L C15	14L C32	14P C14	14P C32
...P1	1.9							
...P2	3.1							
...SCS/SCM/SRM/SRS ...ECN/EQN	0.3							

Additional weights MCA servo motors

	10I C40 ...S00	13I C41 ...S00	13I C34 ...F10	14L C20 ...S00	14L C41 ...S00	14L C16 ...F10	14L C35 ...F10	17N C23 ...S00	17N C41 ...S00	17N C17 ...F10	17N C35 ...F10	
...P1/P5								2.4				
...P2/P6	0.8	1.4		1.5								
...CDD ...ECN/EQN/EQI ...SCS/SCM/SRM/SRS/S20 ...T20	0.3	0.5		0.6			0.7					

Additional weights gearbox

	Solid shaft	2nd output shaft end	Hollow shaft with shrink disc	Flange	Threaded hole circle torque plate	Casing foot torque plate
	V□□	V□□	S□□	□□K		
GKR03...	0.2	0.1	0.3	0.4	0.3	
GKR04...	0.3			0.5	0.4	
GKR05...	1	0.3	0.8	1	1.3	2
GKR06...	1.7	0.5	1		2.1	3.7

Weights in [kg]

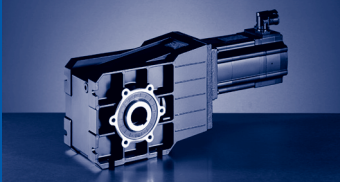

► $i_g = z_g / z_t$

	i	z_g	z_t
GKR03-2	5.411	1120	207
	6.222	1288	
	7.111	1600	
	8.178	1840	
	9.101	1720	
	10.466	1978	189
	11.64	2200	
	13.386	2530	
	15.111	2040	
	17.378	2346	
	19.365	2440	126
	22.27	2806	
	25.051	2480	
	28.808	2852	
	32.593	2640	
	37.481	3036	81
	42.222	3800	
	48.556	4370	
	53.889	3880	
	61.972	4462	
GKR04-2	5.185	1400	270
	5.963	1610	
	7.111	1600	
	8.178	1840	
	9.101	1720	
	10.466	1978	189
	11.449	2576	
	12.698	2400	
	14.603	2760	
	15.556	2520	
	17.889	2898	162
	19.556	2640	
	22.489	3036	
	25.185	2720	
	28.963	3128	
	31.919	3160	99
	36.707	3634	
	40	3240	
	46	3726	
	52.698	3320	
60.603	3818	63	
3.565	1925		540
4.889	2200		
6.257	2365		
6.883	2065		

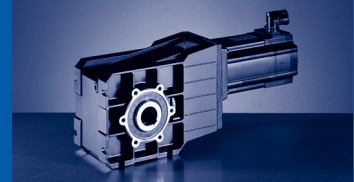

► $i_g = z_g / z_t$

	i	z_g	z_t
GKR05-2	7.817	2345	300
	9.44	2360	250
	10.72	2680	
	12.081	2537	210
	13.216	3304	250
	13.719	2881	210
	15.008	3752	250
	16.857	3540	210
	19.143	4020	
	20.65	3717	180
	23.45	4221	
	26.878	4838	
	30.522	5494	
	33.433	4012	120
	37.967	4556	
	43.267	5192	
	49.133	5896	
	52.51	5251	100
	59.63	5963	
	67.113	5369	80
76.213	6097		
GKR06-2	3.431	1750	510
	4.706	2000	425
	6.022	2150	357
	6.481	1750	270
	7.146	1715	240
	8.889	2000	225
	9.8	1960	200
	11.376	2150	189
	12.444	2800	225
	13.72	2744	200
	15.873	3000	189
	17.5	2940	168
	19.444	3150	162
	21.438	3087	144
	25.309	4100	162
	27.903	4018	144
	31.481	3400	108
	34.708	3332	96
	40.741	4400	108
	44.917	4312	96
	49.444	4450	90
	54.513	4361	80
	62.5	4500	72
68.906	4410	64	

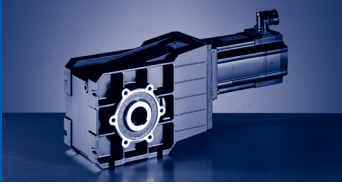

GKR [i]

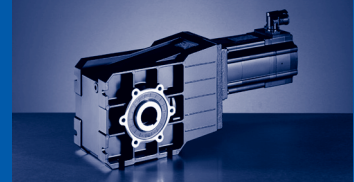

$M_{2GN} \leq 45 \text{ Nm}$

GKR03-2S				06CC41	06FC41	06IC41
				...500	...500	...500
i	M_{2GN}	J_G	M_1			
			n_1	4050	4050	4050
			I_{M230}	2.6	2.9	3.2
			I_{M400}	1.3	1.5	1.6
			P_N	0.25	0.51	0.64
			J_M	0.17	0.25	0.33
5.411	39	0.31	M_2		6	8
			c		4.6	3.7
			n_2 Eck		749	749
			n_2 th		749	749
6.222	41	0.28	M_2		7	9
			c		4.1	3.3
			n_2 Eck		651	651
			n_2 th		651	651
7.111	43	0.2	M_2		8	10
			c		3.8	3.1
			n_2 Eck		570	570
			n_2 th		570	570
8.178	44	0.18	M_2		9	11
			c		3.4	2.7
			n_2 Eck		495	495
			n_2 th		495	495
9.101	45	0.13	M_2		10	13
			c		3.1	2.5
			n_2 Eck		445	445
			n_2 th		445	445
10.466	45	0.12	M_2	6	12	15
			c	5.4	2.7	2.2
			n_2 Eck	387	387	387
			n_2 th	387	387	387
11.64	45	0.09	M_2	6	13	16
			c	4.9	2.4	2
			n_2 Eck	348	348	348
			n_2 th	348	348	348
13.386	45	0.08	M_2	7	15	19
			c	4.2	2.1	1.7
			n_2 Eck	303	303	303
			n_2 th	303	303	303
15.111	45	0.06	M_2	8	17	21
			c	3.8	1.9	1.5
			n_2 Eck	268	268	268
			n_2 th	268	268	268
17.378	45	0.06	M_2	10	20	25
			c	3.3	1.6	1.3
			n_2 Eck	233	233	233
			n_2 th	233	233	233
19.365	45	0.04	M_2	11	22	28
			c	2.9	1.5	1.2
			n_2 Eck	209	209	209
			n_2 th	209	209	209
22.27	45	0.05	M_2	12	25	32
			c	2.6	1.3	1
			n_2 Eck	182	182	182
			n_2 th	182	182	182
25.051	45	0.03	M_2	14	28	36
			c	2.6	1.3	1
			n_2 Eck	162	162	162
			n_2 th	162	162	162

$M \dots$ [Nm]
 $n \dots$ [min^{-1}]
 $J \dots$ [kgcm^2]

$P \dots$ [kW]
 $I \dots$ [A]
 $i \dots$ [-]
 $c \dots$ [-]

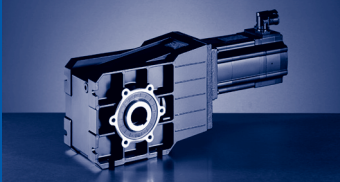

GKR [Nm]

GKR□□-2S (MCS)

$M_{2GN} \leq 45 \text{ Nm}$

GKR03-2S				06CC41	06FC41	06IC41
				...500	...500	...500
i	M_{2GN}	J_G	M_1	0.6	1.2	1.5
			n_1	4050	4050	4050
			I_{M230}	2.6	2.9	3.2
			I_{M400}	1.3	1.5	1.6
			P_N	0.25	0.51	0.64
			J_M	0.17	0.25	0.33
28.808	45	0.02	M_2	16	33	
			c	2.2	1.1	
			$n_{2 \text{ Eck}}$	141	141	
			$n_{2 \text{ th}}$	141	141	
32.593	45	0.02	M_2	18		
			c	2		
			$n_{2 \text{ Eck}}$	124		
			$n_{2 \text{ th}}$	124		
37.481	45	0.02	M_2	21		
			c	1.7		
			$n_{2 \text{ Eck}}$	108		
			$n_{2 \text{ th}}$	108		

M ... [Nm]
 n ... [min⁻¹]
 J ... [kgcm²]

P ... [kW]
 I ... [A]
 i [-]
 c [-]

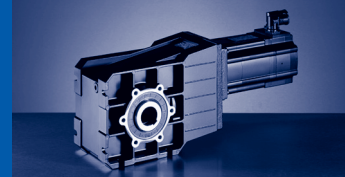

$M_{2GN} \leq 90 \text{ Nm}$

GKR04-2S				06CC41	06FC41	06IC41	09DC41	09FC38	09HC41	09LC41
				...500	...500	...500	...500	...500	...500	...500
i	M_{2GN}	J_G	M_1	0.6	1.2	1.5	2.3	3.1	3.8	4.5
			n_1	4050	4050	4050	4050	3750	4050	4050
			I_{M230}	2.6	2.9	3.2	4.6	5	6.8	8.4
			I_{M400}	1.3	1.5	1.6	2.3	2.5	3.4	4.2
			P_N	0.25	0.51	0.64	1	1.2	1.6	1.9
			J_M	0.17	0.25	0.33	1.13	1.53	1.93	2.83
5.185	69	0.81	M_2				11	15	18	22
			c				4.4	3.3	2.6	2.2
			$n_{2 \text{ Eck}}$				781	723	781	781
			$n_{2 \text{ th}}$				679	645	617	596
5.963	72	0.72	M_2				13	17	21	25
			c				4	3	2.4	2
			$n_{2 \text{ Eck}}$				679	629	679	679
			$n_{2 \text{ th}}$				581	551	527	509
7.111	78	0.45	M_2			10	15	21	25	30
			c			5.5	3.6	2.7	2.2	1.8
			$n_{2 \text{ Eck}}$			570	570	527	570	570
			$n_{2 \text{ th}}$			569	530	506	485	459
8.178	81	0.41	M_2			11	17	24	29	35
			c			5	3.3	2.5	2	1.7
			$n_{2 \text{ Eck}}$			495	495	459	495	495
			$n_{2 \text{ th}}$			487	454	432	415	382
9.101	84	3.27	M_2		10	12	19	26	33	39
			c		5.8	4.7	3.1	2.3	1.9	1.6
			$n_{2 \text{ Eck}}$		445	445	445	412	445	445
			$n_{2 \text{ th}}$		445	445	445	412	425	389
10.466	89	0.3	M_2		11	14	22	30	38	45
			c		5.3	4.3	2.8	2.1	1.7	1.4
			$n_{2 \text{ Eck}}$		387	387	387	358	387	387
			$n_{2 \text{ th}}$		387	387	387	358	352	324
11.449	90	0.26	M_2		13	16	25	33	41	49
			c		5	4	2.6	2	1.6	1.3
			$n_{2 \text{ Eck}}$		354	354	354	328	354	354
			$n_{2 \text{ th}}$		354	354	354	328	324	300
12.698	90	1.99	M_2		14	18	27	37	46	54
			c		4.5	3.6	2.3	1.8	1.4	1.2
			$n_{2 \text{ Eck}}$		319	319	319	295	319	319
			$n_{2 \text{ th}}$		319	319	319	295	318	299
14.603	90	0.18	M_2		16	20	32	43	53	62
			c		3.9	3.1	2	1.5	1.2	1
			$n_{2 \text{ Eck}}$		277	277	277	257	277	277
			$n_{2 \text{ th}}$		277	277	277	257	263	248
15.556	90	1.47	M_2		17	22	34	46	56	
			c		3.7	2.9	1.9	1.5	1.2	
			$n_{2 \text{ Eck}}$		260	260	260	241	260	
			$n_{2 \text{ th}}$		260	260	260	241	260	
17.889	90	0.14	M_2		20	25	39	53	65	
			c		3.2	2.5	1.7	1.3	1	
			$n_{2 \text{ Eck}}$		226	226	226	210	226	
			$n_{2 \text{ th}}$		226	226	226	210	226	
19.556	90	0.1	M_2	11	22	27				
			c	5.8	2.9	2.3				
			$n_{2 \text{ Eck}}$	207	207	207				
			$n_{2 \text{ th}}$	207	207	207				
22.489	90	0.09	M_2	12	25	32				
			c	5	2.5	2				
			$n_{2 \text{ Eck}}$	180	180	180				
			$n_{2 \text{ th}}$	180	180	180				

$M \dots$ [Nm]
 $n \dots$ [min^{-1}]
 $J \dots$ [kgcm^2]

$P \dots$ [kW]
 $I \dots$ [A]
 i [-]
 c [-]

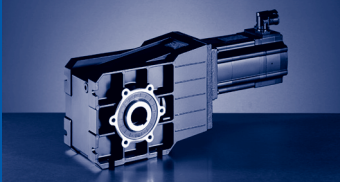

GKR [Nm]

GKR□□-2S (MCS)

$M_{2GN} \leq 90 \text{ Nm}$

GKR04-2S				06CC41	06FC41	06IC41	09DC41	09FC38	09HC41	09LC41
				...S00	...S00	...S00	...S00	...S00	...S00	...S00
i	M_{2GN}	J_G	M_1							
			n_1	4050	4050	4050	4050	3750	4050	4050
			I_{M230}	2.6	2.9	3.2	4.6	5	6.8	8.4
			I_{M400}	1.3	1.5	1.6	2.3	2.5	3.4	4.2
			P_N	0.25	0.51	0.64	1	1.2	1.6	1.9
			J_M	0.17	0.25	0.33	1.13	1.53	1.93	2.83
25.185	90	0.07	M_2	14	28	35				
			c	5.1	2.6	2.1				
			$n_{2 \text{ Eck}}$	161	161	161				
			$n_{2 \text{ th}}$	161	161	161				
28.963	90	0.06	M_2	16	33	41				
			c	4.5	2.2	1.8				
			$n_{2 \text{ Eck}}$	140	140	140				
			$n_{2 \text{ th}}$	140	140	140				

M ... [Nm]
 n ... [min⁻¹]
 J ... [kgcm²]

P ... [kW]
 I ... [A]
 i [-]
 c [-]

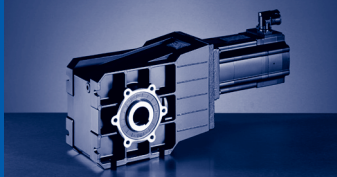

$M_{2GN} \leq 240 \text{ Nm}$

GKR05-2S				06FC41	06IC41	09DC41	09FC38	09HC41	09LC41	12DC20	12DC41	12HC15	12HC30	12HC35	12LC20		
				...500	...500	...500	...500	...500	...500	...500	...500	...500	...500	...500	...500		
i	M_{2GN}	J_G	M_1	1.2	1.5	2.3	3.1	3.8	4.5	5.5	4.3	10	8	7.5	13.5		
			n_1	4050	4050	4050	3750	4050	4050	1950	4050	1500	3000	3525	1950		
			I_{M230}	2.9	3.2	4.6	5	6.8	8.4	5.2	8.8	7.6	10.5		11.8		
			I_{M400}	1.5	1.6	2.3	2.5	3.4	4.2	2.6	4.5	3.8		5.7	5.9		
			P_N	0.51	0.64	1	1.2	1.6	1.9	1.1	1.8	1.6	2.5	2.8	2.8		
			J_M	0.25	0.33	1.13	1.53	1.93	2.83	4.12	4.12	7.42	7.42	7.42	10.72		
3.565	116	4.95	M_2						15								
			c						5.4								
			$n_{2 \text{ Eck}}$						1136								
			$n_{2 \text{ th}}$						860								
3.565	138	4.95	M_2									33	26		45		
			c									4.1	4		2.8		
			$n_{2 \text{ Eck}}$									421	842		547		
			$n_{2 \text{ th}}$									421	812		547		
4.889	139	2.79	M_2					17	20								
			c					5.7	4.8								
			$n_{2 \text{ Eck}}$					828	828								
			$n_{2 \text{ th}}$					739	717								
4.889	147	2.79	M_2							24	19	45	36		62		
			c							5.3	5.3	3.2	3.1		2.1		
			$n_{2 \text{ Eck}}$							399	828	307	614		399		
			$n_{2 \text{ th}}$							399	730	307	614		399		
6.257	150	1.79	M_2				17	22	26								
			c				6	4.8	4								
			$n_{2 \text{ Eck}}$				599	647	647								
			$n_{2 \text{ th}}$				599	609	592								
6.257	156	1.79	M_2							32	25	58	47		80		
			c							4.4	4.4	2.6	2.6		1.8		
			$n_{2 \text{ Eck}}$							312	647	240	480		312		
			$n_{2 \text{ th}}$							312	601	240	479		312		
6.883	179	2.57	M_2					24	28	35	27	64	51		87		
			c					5.2	4.4	4.6	4.6	2.7	2.7		1.9		
			$n_{2 \text{ Eck}}$					588	588	283	588	218	436		283		
			$n_{2 \text{ th}}$					441	427	283	431	218	388		283		
7.817	187	2.32	M_2				22	27	32	39	31	73	58		100		
			c				6	4.8	4	4.2	4.2	2.5	2.5		1.7		
			$n_{2 \text{ Eck}}$				480	518	518	250	518	192	384		250		
			$n_{2 \text{ th}}$				399	382	370	249	373	192	335		249		
9.44	191	1.53	M_2				27	33	39	48	38	89	71	66	121		
			c				5.1	4	3.4	3.5	3.6	2.1	2.1	2.1	1.4		
			$n_{2 \text{ Eck}}$				397	429	429	207	429	159	318	373	207		
			$n_{2 \text{ th}}$				375	359	348	207	351	159	316	316	207		
10.72	204	1.4	M_2				30	38	45	55	43	101	81	76	137		
			c				4.8	3.8	3.2	3.3	3.3	2	2	2	1.4		
			$n_{2 \text{ Eck}}$				350	378	378	182	378	140	280	329	182		
			$n_{2 \text{ th}}$				326	313	303	182	305	140	275	275	182		
12.081	208	1.02	M_2			25	34	42	51	62	48	114	91		155		
			c			5.7	4.3	3.4	2.9	3	3	1.8	1.8		1.2		
			$n_{2 \text{ Eck}}$			335	310	335	335	161	335	124	248		161		
			$n_{2 \text{ th}}$			325	310	298	289	161	292	124	248		161		
13.216	214	0.87	M_2			28	38	47	55	68	53	125	100		169		
			c			5.3	4.1	3.2	2.7	2.8	2.9	1.7	1.7		1.2		
			$n_{2 \text{ Eck}}$			307	284	307	307	148	307	114	227		148		
			$n_{2 \text{ th}}$			304	284	280	271	148	274	114	227		148		
13.719	217	0.94	M_2			29	39	48	58	70	55	129	104		176		
			c			5.2	4	3.1	2.7	2.8	2.8	1.7	1.7		1.1		
			$n_{2 \text{ Eck}}$			295	273	295	295	142	295	109	219		142		
			$n_{2 \text{ th}}$			282	269	259	251	142	253	109	216		142		

$M \dots$ [Nm]
 $n \dots$ [min^{-1}]
 $J \dots$ [kgcm^2]

$P \dots$ [kW]
 $I \dots$ [A]
 $i [-]$
 $c [-]$

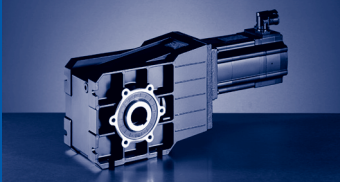

GKR [Nm]

GKR□□-2S (MCS)

$M_{2GN} \leq 240 \text{ Nm}$

GKR05-2S				06FC41	06IC41	09DC41	09FC38	09HC41	09LC41	12DC20	12DC41	12HC15	12HC30	12HC35	12LC20	
				...500	...500	...500	...500	...500	...500	...500	...500	...500	...500	...500	...500	
i	M_{2GN}	J_G	M_1	1.2	1.5	2.3	3.1	3.8	4.5	5.5	4.3	10	8	7.5	13.5	
			n_1	4050	4050	4050	3750	4050	4050	1950	4050	1500	3000	3525	1950	
			I_{M230}	2.9	3.2	4.6	5	6.8	8.4	5.2	8.8	7.6	10.5		11.8	
			I_{M400}	1.5	1.6	2.3	2.5	3.4	4.2	2.6	4.5	3.8		5.7	5.9	
			P_N	0.51	0.64	1	1.2	1.6	1.9	1.1	1.8	1.6	2.5	2.8	2.8	
			J_M	0.25	0.33	1.13	1.53	1.93	2.83	4.12	4.12	7.42	7.42	7.42	10.72	
15.008	223	0.81	M_2			31	43	53	63	77	60	142	113		192	
			c			4.9	3.7	3	2.5	2.6	2.6	1.6	1.6		1.1	
			$n_{2 \text{ Eck}}$			270	250	270	270	270	130	270	100	200		130
			$n_{2 \text{ th}}$			264	250	243	235	130	237	100	200		130	
16.857	240	0.6	M_2			35	48	60	71	87	68	159	127		216	
			c			4.7	3.6	2.8	2.4	2.5	2.5	1.5	1.5		1	
			$n_{2 \text{ Eck}}$			240	223	240	240	116	240	89	178		116	
			$n_{2 \text{ th}}$			240	222	240	240	116	240	89	178		116	
19.143	240	0.55	M_2			40	55	68	81	99	77	181	145			
			c			4.1	3.1	2.5	2.1	2.2	2.2	1.3	1.3			
			$n_{2 \text{ Eck}}$			212	196	212	212	102	212	78	157			
			$n_{2 \text{ th}}$			212	196	212	212	102	212	78	157			
20.65	231	0.44	M_2		28											
			c		5.7											
			$n_{2 \text{ Eck}}$		196											
			$n_{2 \text{ th}}$		196											
20.65	240	0.44	M_2			44	60	74	87	107	83	196	157	147		
			c			3.8	2.9	2.3	2	2	1.2	1.2	1.2	1.2		
			$n_{2 \text{ Eck}}$			196	182	196	196	94	196	73	145	171		
			$n_{2 \text{ th}}$			196	182	196	196	94	196	73	145	171		
23.45	240	0.41	M_2		32	50	68	84	99	122	95	223	178	167		
			c		5.2	3.4	2.6	2	1.7	1.8	1.8	1.1	1.1	1.1		
			$n_{2 \text{ Eck}}$		173	173	160	173	173	83	173	64	128	150		
			$n_{2 \text{ th}}$		173	173	160	173	173	83	173	64	128	147		
26.878	240	0.27	M_2		37	57	78	96	114							
			c		5.1	3.3	2.5	2	1.7							
			$n_{2 \text{ Eck}}$		151	151	140	151	151							
			$n_{2 \text{ th}}$		151	151	140	151	151							
30.522	240	0.25	M_2	33	42	65	89	109	130							
			c	5.6	4.5	2.9	2.2	1.8	1.5							
			$n_{2 \text{ Eck}}$	133	133	133	123	133	133							
			$n_{2 \text{ th}}$	133	133	133	123	133	133							
33.433	240	0.19	M_2	36	46	72	97	120	142							
			c	5.1	4.1	2.7	2	1.6	1.4							
			$n_{2 \text{ Eck}}$	121	121	121	112	121	121							
			$n_{2 \text{ th}}$	121	121	121	112	121	121							
37.967	240	0.18	M_2	42	53	82	111	136	162							
			c	4.5	3.6	2.4	1.8	1.4	1.2							
			$n_{2 \text{ Eck}}$	107	107	107	99	107	107							
			$n_{2 \text{ th}}$	107	107	107	99	107	107							
43.267	240	0.12	M_2	48	60											
			c	4.4	3.5											
			$n_{2 \text{ Eck}}$	94	94											
			$n_{2 \text{ th}}$	94	94											
49.133	240	0.11	M_2	54	68											
			c	3.9	3.1											
			$n_{2 \text{ Eck}}$	82	82											
			$n_{2 \text{ th}}$	82	82											
52.51	240	0.09	M_2	58	73											
			c	3.6	2.9											
			$n_{2 \text{ Eck}}$	77	77											
			$n_{2 \text{ th}}$	77	77											

$M \dots [\text{Nm}]$
 $n \dots [\text{min}^{-1}]$
 $J \dots [\text{kgcm}^2]$

$P \dots [\text{kW}]$
 $I \dots [\text{A}]$
 $i \dots [-]$
 $c \dots [-]$

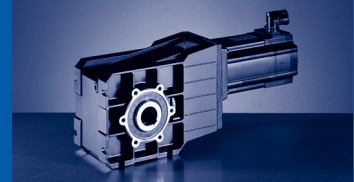

$M_{2GN} \leq 240 \text{ Nm}$

GKR05-2S				06FC41	06IC41	09DC41	09FC38	09HC41	09LC41	12DC20	12DC41	12HC15	12HC30	12HC35	12LC20	
				...S00	...S00	...S00	...S00	...S00	...S00	...S00	...S00	...S00	...S00	...S00	...S00	
i	M_{2GN}	J_G	M_1	1.2	1.5	2.3	3.1	3.8	4.5	5.5	4.3	10	8	7.5	13.5	
			n_1	4050	4050	4050	3750	4050	4050	1950	4050	1500	3000	3525	1950	
			I_{M230}	2.9	3.2	4.6	5	6.8	8.4	5.2	8.8	7.6	10.5		11.8	
			I_{M400}	1.5	1.6	2.3	2.5	3.4	4.2	2.6	4.5	3.8		5.7	5.9	
			P_N	0.51	0.64	1	1.2	1.6	1.9	1.1	1.8	1.6	2.5	2.8	2.8	
			J_M	0.25	0.33	1.13	1.53	1.93	2.83	4.12	4.12	7.42	7.42	7.42	10.72	
59.63	240	0.08	M_2	66	84											
			c	3.2	2.6											
			n_2 Eck	68	68											
			n_2 th	68	68											

M ... [Nm]
n ... [min^{-1}]
J ... [kgcm^2]

P ... [kW]
I ... [A]
i [-]
c [-]

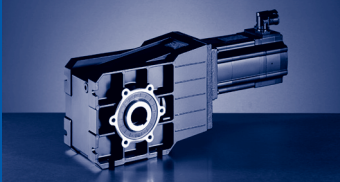

GKR [Nm]

GKR□□-2S (MCS)

$M_{2GN} \leq 450 \text{ Nm}$

GKR06-2S				06FC41	06IC41	09DC41	09FC38	09HC41	09LC41	12DC20	12DC41	12HC15	12HC30
				...500	...500	...500	...500	...500	...500	...500	...500	...500	...500
i	M_{2GN}	J_G	M_1	1.2	1.5	2.3	3.1	3.8	4.5	5.5	4.3	10	8
			n_1	4050	4050	4050	3750	4050	4050	1950	4050	1500	3000
			I_{M230}	2.9	3.2	4.6	5	6.8	8.4	5.2	8.8	7.6	10.5
			I_{M400}	1.5	1.6	2.3	2.5	3.4	4.2	2.6	4.5	3.8	
			P_N	0.51	0.64	1	1.2	1.6	1.9	1.1	1.8	1.6	2.5
			J_M	0.25	0.33	1.13	1.53	1.93	2.83	4.12	4.12	7.42	7.42
3.431	188	9.58	M_2									31	25
			c									5.8	5.7
			$n_{2 \text{ Eck}}$									437	874
			$n_{2 \text{ th}}$									437	765
3.431	200	9.58	M_2										
			c										
			$n_{2 \text{ Eck}}$										
			$n_{2 \text{ th}}$										
4.706	215	5.61	M_2									43	34
			c									4.8	4.8
			$n_{2 \text{ Eck}}$									319	638
			$n_{2 \text{ th}}$									319	623
4.706	250	5.61	M_2										
			c										
			$n_{2 \text{ Eck}}$										
			$n_{2 \text{ th}}$										
6.022	179	3.66	M_2					21	25				
			c					5.9	5				
			$n_{2 \text{ Eck}}$					673	673				
			$n_{2 \text{ th}}$					586	568				
6.022	231	3.66	M_2									55	44
			c									4	4
			$n_{2 \text{ Eck}}$									249	498
			$n_{2 \text{ th}}$									249	498
6.022	280	3.66	M_2										
			c										
			$n_{2 \text{ Eck}}$										
			$n_{2 \text{ th}}$										
6.481	350	5.11	M_2									59	47
			c									5.7	5.6
			$n_{2 \text{ Eck}}$									231	463
			$n_{2 \text{ th}}$									231	404
7.146	348	4.54	M_2									65	52
			c									5.1	5.1
			$n_{2 \text{ Eck}}$									210	420
			$n_{2 \text{ th}}$									210	359
8.889	405	3.23	M_2									81	65
			c									4.8	4.8
			$n_{2 \text{ Eck}}$									169	338
			$n_{2 \text{ th}}$									169	330
8.889	408	3.23	M_2										
			c										
			$n_{2 \text{ Eck}}$										
			$n_{2 \text{ th}}$										
9.8	384	2.93	M_2									90	72
			c									4.1	4.1
			$n_{2 \text{ Eck}}$									153	306
			$n_{2 \text{ th}}$									153	291
11.376	337	2.21	M_2					39	47				
			c					5.9	5				
			$n_{2 \text{ Eck}}$					356	356				
			$n_{2 \text{ th}}$					310	301				

$M \dots$ [Nm]
 $n \dots$ [min^{-1}]
 $J \dots$ [kgcm^2]

$P \dots$ [kW]
 $I \dots$ [A]
 $i \dots$ [-]
 $c \dots$ [-]

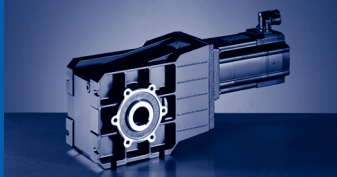

$M_{2GN} \leq 450 \text{ Nm}$

12HC35	12LC20	12LC41	14DC15	14DC36	14HC15	14HC32	14LC15	14LC32	14PC14	14PC32	GKR06-2S			
...500	...500	...500	...500	...500	...500	...500	...500	...500	...500	...500	M_1	J_G	M_{2GN}	i
7.5	13.5	11	9.2	7.5	16	14	23	17.2	30	21	n_1			
3525	1950	4050	1500	3600	1500	3225	1500	3225	1350	3225	I_{M230}			
	11.8										I_{M400}			
5.7	5.9	10.2	4.5	7.5	6.6	11.9	9.7	15	10.8	15.6	P_N			
2.8	2.8	4.7	1.45	2.8	2.5	4.7	3.6	5.8	4.2	7.1	J_M			
7.42	10.72	10.72	8.22	8.22	14.32	14.32	23.44	23.44	34.74	34.82	M_2			
23	43	35									c			
5.8	3.9	3.8									$n_{2 \text{ Eck}}$	9.58	188	3.431
1027	568	1180									$n_{2 \text{ th}}$			
766	568	702									M_2			
					51	44	74	55	97	68	c			
					3.8	3.4	2.7	2.8	2.1	2.3	$n_{2 \text{ Eck}}$	9.58	200	3.431
					437	940	437	940	393	940	$n_{2 \text{ th}}$			
					437	687	437	657	393	627	M_2			
32	59	48									c			
4.8	3.3	3.1									$n_{2 \text{ Eck}}$	5.61	215	4.706
749	414	861									$n_{2 \text{ th}}$			
625	414	573									M_2			
					32	70	61	101	76	133	c			
					5.6	3.5	3.1	2.4	2.5	1.9	$n_{2 \text{ Eck}}$	5.61	250	4.706
					765	319	685	319	685	287	$n_{2 \text{ th}}$			
					642	319	571	319	546	287	M_2			
											c			
											$n_{2 \text{ Eck}}$	3.66	179	6.022
											$n_{2 \text{ th}}$			
42	76	62									M_2			
4.1	2.7	2.6									c			
585	324	673									$n_{2 \text{ Eck}}$	3.66	231	6.022
546	324	501									$n_{2 \text{ th}}$			
											M_2			
					50	41	90	79	130	97	c			
					5.3	4.9	3.1	2.7	2.1	2.2	$n_{2 \text{ Eck}}$	3.66	280	6.022
					249	598	249	536	249	536	$n_{2 \text{ th}}$			
					249	566	249	504	249	482	M_2			
44	81	66									c			
5.7	3.9	3.7									$n_{2 \text{ Eck}}$	5.11	350	6.481
544	301	625									$n_{2 \text{ th}}$			
405	301	371									M_2			
					44	96	84	139	104	183	c			
					5.7	3.6	3.2	2.5	2.6	1.9	$n_{2 \text{ Eck}}$	5.11	350	6.481
					555	231	498	231	498	208	$n_{2 \text{ th}}$			
					404	231	358	231	342	208	M_2			
49	89	73									c			
5.1	3.5	3.4									$n_{2 \text{ Eck}}$	4.54	348	7.146
493	273	567									$n_{2 \text{ th}}$			
360	273	329									M_2			
											c			
											$n_{2 \text{ Eck}}$	3.23	405	8.889
											$n_{2 \text{ th}}$			
61	111	91									M_2			
4.8	3.3	3.1									c			
397	219	456									$n_{2 \text{ Eck}}$	3.23	405	8.889
331	219	303									$n_{2 \text{ th}}$			
											M_2			
											c			
											$n_{2 \text{ Eck}}$	3.23	408	8.889
											$n_{2 \text{ th}}$			
68	123	101									M_2			
4.1	2.8	2.7									c			
360	199	413									$n_{2 \text{ Eck}}$	2.93	384	9.8
291	199	266									$n_{2 \text{ th}}$			
											M_2			
											c			
											$n_{2 \text{ Eck}}$	2.21	337	11.376
											$n_{2 \text{ th}}$			

M ... [Nm]
n ... [min⁻¹]
J ... [kgcm²]

P ... [kW]
I ... [A]
i [-]
c [-]

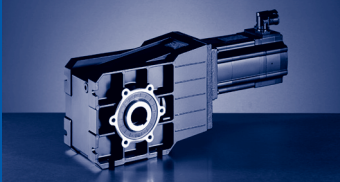

GKR [Nm]

GKR□□-2S (MCS)

$M_{2GN} \leq 450 \text{ Nm}$

GKR06-2S				06FC41	06IC41	09DC41	09FC38	09HC41	09LC41	12DC20	12DC41	12HC15	12HC30
				...500	...500	...500	...500	...500	...500	...500	...500	...500	...500
i	M_{2GN}	J_G	M_1	1.2	1.5	2.3	3.1	3.8	4.5	5.5	4.3	10	8
			n_1	4050	4050	4050	3750	4050	4050	1950	4050	1500	3000
			I_{M230}	2.9	3.2	4.6	5	6.8	8.4	5.2	8.8	7.6	10.5
			I_{M400}	1.5	1.6	2.3	2.5	3.4	4.2	2.6	4.5	3.8	
			P_N	0.51	0.64	1	1.2	1.6	1.9	1.1	1.8	1.6	2.5
			J_M	0.25	0.33	1.13	1.53	1.93	2.83	4.12	4.12	7.42	7.42
11.376	436	2.21	M_2 c									105	84
			n_2 Eck									4	4
			n_2 th									132	264
			n_2 th									132	264
12.444	353	1.89	M_2 c					43	51				
			n_2 Eck					5.6	4.8				
			n_2 th					326	326				
			n_2 th					290	282				
12.444	450	1.89	M_2 c									115	92
			n_2 Eck									3.8	3.8
			n_2 th									121	241
			n_2 th									121	241
13.72	389	1.73	M_2 c					47	56				
			n_2 Eck					5.6	4.8				
			n_2 th					295	295				
			n_2 th					263	255				
13.72	426	1.73	M_2 c							68	53	127	102
			n_2 Eck							5.5	5.5	3.3	3.2
			n_2 th							142	295	109	219
			n_2 th							142	262	109	219
15.873	379	1.32	M_2 c				44	55	66				
			n_2 Eck				6	4.8	4				
			n_2 th				236	255	255				
			n_2 th				236	242	236				
15.873	450	1.32	M_2 c							79	62	148	118
			n_2 Eck							5	5	3	3
			n_2 th							123	255	95	189
			n_2 th							123	244	95	189
17.5	418	1.23	M_2 c				49	61	72				
			n_2 Eck				6	4.8	4				
			n_2 th				214	231	231				
			n_2 th				214	220	214				
17.5	450	1.23	M_2 c							88	69	163	131
			n_2 Eck							4.5	4.5	2.7	2.7
			n_2 th							111	231	86	171
			n_2 th							111	218	86	171
19.444	398	0.99	M_2 c				55	68	81				
			n_2 Eck				5.1	4.1	3.4				
			n_2 th				193	208	208				
			n_2 th				193	208	208				
19.444	450	0.99	M_2 c							98	77	182	146
			n_2 Eck							4.1	4.1	2.4	2.4
			n_2 th							100	208	77	154
			n_2 th							100	208	77	154
21.438	439	0.93	M_2 c				60	75	89				
			n_2 Eck				5.1	4.1	3.4				
			n_2 th				175	189	189				
			n_2 th				175	189	189				
21.438	450	0.93	M_2 c							109	85	201	161
			n_2 Eck							3.7	3.7	2.2	2.2
			n_2 th							91	189	70	140
			n_2 th							91	189	70	140

$M \dots$ [Nm]
 $n \dots$ [min^{-1}]
 $J \dots$ [kgcm^2]

$P \dots$ [kW]
 $I \dots$ [A]
 $i \dots$ [-]
 $c \dots$ [-]

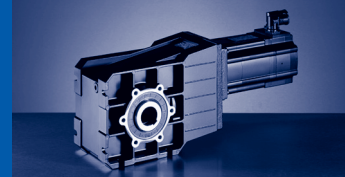

$M_{2GN} \leq 450 \text{ Nm}$

12HC35	12LC20	12LC41	14DC15	14DC36	14HC15	14HC32	14LC15	14LC32	14PC14	14PC32	GKR06-2S			
...S00	...S00	...S00	...S00	...S00	...S00	...S00	...S00	...S00	...S00	...S00	M_1	J_G	M_{2GN}	i
7.5	13.5	11	9.2	7.5	16	14	23	17.2	30	21	n_1			
3525	1950	4050	1500	3600	1500	3225	1500	3225	1350	3225	I_{M230}			
	11.8										I_{M400}			
5.7	5.9	10.2	4.5	7.5	6.6	11.9	9.7	15	10.8	15.6	P_N			
2.8	2.8	4.7	1.45	2.8	2.5	4.7	3.6	5.8	4.2	7.1	J_M			
7.42	10.72	10.72	8.22	8.22	14.32	14.32	23.44	23.44	34.74	34.82	M_2			
78	143	117	96	78	170	149	247	184	323	226	c	2.21	436	11.376
4	2.7	2.6	4.4	4	2.5	2.2	1.8	1.8	1.3	1.5	$n_{2 \text{ Eck}}$			
310	171	356	132	317	132	284	132	284	119	284	$n_{2 \text{ th}}$			
289	171	265	132	289	132	256	132	237	119	211	M_2			
											c	1.89	353	12.444
											$n_{2 \text{ Eck}}$			
											$n_{2 \text{ th}}$			
86	157	128	105	86	186	164	270	202	354	247	M_2			
3.8	2.6	2.5	4.1	3.8	2.4	2.1	1.7	1.7	1.3	1.4	c	1.89	450	12.444
283	157	326	121	289	121	259	121	259	109	259	$n_{2 \text{ Eck}}$			
270	157	248	121	270	121	240	121	218	108	196	$n_{2 \text{ th}}$			
											M_2			
											c	1.73	389	13.72
											$n_{2 \text{ Eck}}$			
											$n_{2 \text{ th}}$			
95	174	142	117	95	206	181	298	223	391	273	M_2			
3.3	2.2	2.1	3.6	3.3	2	1.8	1.4	1.5	1.1	1.2	c	1.73	426	13.72
257	142	295	109	262	109	235	109	235	98	235	$n_{2 \text{ Eck}}$			
238	142	218	109	238	109	204	109	182	98	165	$n_{2 \text{ th}}$			
											M_2			
											c	1.32	379	15.873
											$n_{2 \text{ Eck}}$			
											$n_{2 \text{ th}}$			
111	201	164	135	111	239	210	346	258		316	M_2			
3	2	2	3.2	3	1.9	1.7	1.3	1.3		1.1	c	1.32	450	15.873
222	123	255	95	227	95	203	95	203		203	$n_{2 \text{ Eck}}$			
222	123	206	95	223	95	189	95	172		158	$n_{2 \text{ th}}$			
											M_2			
											c	1.23	418	17.5
											$n_{2 \text{ Eck}}$			
											$n_{2 \text{ th}}$			
122	222	181	150	122	264	232	382	285			M_2			
2.7	1.8	1.8	2.9	2.7	1.7	1.5	1.2	1.2			c	1.23	450	17.5
201	111	231	86	206	86	184	86	184			$n_{2 \text{ Eck}}$			
199	111	177	86	199	86	164	86	150			$n_{2 \text{ th}}$			
											M_2			
											c	0.99	398	19.444
											$n_{2 \text{ Eck}}$			
											$n_{2 \text{ th}}$			
136	248	202	167	136	294	258	425	317			M_2			
2.4	1.7	1.6	2.7	2.4	1.5	1.4	1.1	1.1			c	0.99	450	19.444
181	100	208	77	185	77	166	77	166			$n_{2 \text{ Eck}}$			
181	100	177	77	185	77	163	77	149			$n_{2 \text{ th}}$			
											M_2			
											c	0.93	439	21.438
											$n_{2 \text{ Eck}}$			
											$n_{2 \text{ th}}$			
151	274	223	185	151	325	284					M_2			
2.2	1.5	1.4	2.4	2.2	1.4	1.2					c	0.93	450	21.438
164	91	189	70	168	70	150					$n_{2 \text{ Eck}}$			
164	91	153	70	167	70	141					$n_{2 \text{ th}}$			

$M \dots$ [Nm]
 $n \dots$ [min^{-1}]
 $J \dots$ [kgcm^2]

$P \dots$ [kW]
 $I \dots$ [A]
 i [-]
 c [-]

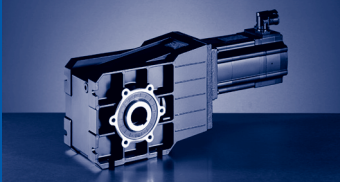

GKR [Nm]

GKR□□-2S (MCS)

$M_{2GN} \leq 450 \text{ Nm}$

GKR06-2S				06FC41	06IC41	09DC41	09FC38	09HC41	09LC41	12DC20	12DC41	12HC15	12HC30
				...500	...500	...500	...500	...500	...500	...500	...500	...500	...500
i	M_{2GN}	J_G	M_1	1.2	1.5	2.3	3.1	3.8	4.5	5.5	4.3	10	8
			n_1	4050	4050	4050	3750	4050	4050	1950	4050	1500	3000
			I_{M230}	2.9	3.2	4.6	5	6.8	8.4	5.2	8.8	7.6	10.5
			I_{M400}	1.5	1.6	2.3	2.5	3.4	4.2	2.6	4.5	3.8	
			P_N	0.51	0.64	1	1.2	1.6	1.9	1.1	1.8	1.6	2.5
			J_M	0.25	0.33	1.13	1.53	1.93	2.83	4.12	4.12	7.42	7.42
25.309	416	0.63	M_2				72	89	106				
			c				4.7	3.7	3.1				
			$n_{2 \text{ Eck}}$				148	160	160				
			$n_{2 \text{ th}}$				148	160	160				
25.309	450	0.63	M_2							129	101	238	190
			c							3.4	3.6	1.9	2.1
			$n_{2 \text{ Eck}}$							77	160	59	119
			$n_{2 \text{ th}}$							77	160	59	119
27.903	450	0.59	M_2				79	98	117	143	111	263	210
			c				4.6	3.7	3.1	3.1	3.2	1.7	1.9
			$n_{2 \text{ Eck}}$				134	145	145	70	145	54	108
			$n_{2 \text{ th}}$				134	145	145	70	145	54	108
31.481	291	0.46	M_2		43								
			c		5.3								
			$n_{2 \text{ Eck}}$		129								
			$n_{2 \text{ th}}$		129								
31.481	431	0.46	M_2			66	90	111	132				
			c			5.1	3.9	3.1	2.6				
			$n_{2 \text{ Eck}}$			129	119	129	129				
			$n_{2 \text{ th}}$			129	119	129	129				
31.481	450	0.46	M_2							161	126	297	238
			c							2.7	2.9	1.5	1.7
			$n_{2 \text{ Eck}}$							62	129	48	95
			$n_{2 \text{ th}}$							62	129	48	95
34.708	321	0.43	M_2		47								
			c		5.3								
			$n_{2 \text{ Eck}}$		117								
			$n_{2 \text{ th}}$		117								
34.708	450	0.43	M_2			73	99	123	146	179	139	328	262
			c			4.8	3.7	2.9	2.5	2.5	2.6	1.4	1.5
			$n_{2 \text{ Eck}}$			117	108	117	117	56	117	43	86
			$n_{2 \text{ th}}$			117	108	117	117	56	117	43	86
40.741	302	0.28	M_2	44	56								
			c	5.9	4.7								
			$n_{2 \text{ Eck}}$	99	99								
			$n_{2 \text{ th}}$	99	99								
40.741	447	0.28	M_2			86	117	144	172				
			c			4.5	3.5	2.8	2.3				
			$n_{2 \text{ Eck}}$			99	92	99	99				
			$n_{2 \text{ th}}$			99	92	99	99				
44.917	333	0.27	M_2	49	62								
			c	5.9	4.7								
			$n_{2 \text{ Eck}}$	90	90								
			$n_{2 \text{ th}}$	90	90								
44.917	450	0.27	M_2			95	129	160	190				
			c			4.2	3.2	2.5	2.1				
			$n_{2 \text{ Eck}}$			90	84	90	90				
			$n_{2 \text{ th}}$			90	83	90	90				
49.444	306	0.21	M_2	54	68								
			c	4.9	3.9								
			$n_{2 \text{ Eck}}$	82	82								
			$n_{2 \text{ th}}$	82	82								

$M \dots [\text{Nm}]$
 $n \dots [\text{min}^{-1}]$
 $J \dots [\text{kgcm}^2]$

$P \dots [\text{kW}]$
 $I \dots [\text{A}]$
 $i \dots [-]$
 $c \dots [-]$

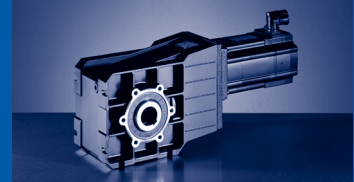

$M_{2GN} \leq 450 \text{ Nm}$

12HC35	12LC20	12LC41	14DC15	14DC36	14HC15	14HC32	14LC15	14LC32	14PC14	14PC32	GKR06-2S			
...S00	...S00	...S00	...S00	...S00	...S00	...S00	...S00	...S00	...S00	...S00	M_1	J_G	M_{2GN}	i
7.5	13.5	11	9.2	7.5	16	14	23	17.2	30	21	n_1			
3525	1950	4050	1500	3600	1500	3225	1500	3225	1350	3225	I_{M230}			
	11.8										I_{M400}			
5.7	5.9	10.2	4.5	7.5	6.6	11.9	9.7	15	10.8	15.6	P_N			
2.8	2.8	4.7	1.45	2.8	2.5	4.7	3.6	5.8	4.2	7.1	J_M			
7.42	10.72	10.72	8.22	8.22	14.32	14.32	23.44	23.44	34.74	34.82	M_2			
											c	0.63	416	25.309
											$n_{2 \text{ Eck}}$			
											$n_{2 \text{ th}}$			
178	323	263									M_2			
2.1	1.4	1.4									c	0.63	450	25.309
139	77	160									$n_{2 \text{ Eck}}$			
139	77	150									$n_{2 \text{ th}}$			
197	357	291									M_2			
1.9	1.3	1.3									c	0.59	450	27.903
126	70	145									$n_{2 \text{ Eck}}$			
126	70	130									$n_{2 \text{ th}}$			
											M_2			
											c	0.46	291	31.481
											$n_{2 \text{ Eck}}$			
											$n_{2 \text{ th}}$			
											M_2			
											c	0.46	431	31.481
											$n_{2 \text{ Eck}}$			
											$n_{2 \text{ th}}$			
223	403	329									M_2			
1.7	1.1	1.1									c	0.46	450	31.481
112	62	129									$n_{2 \text{ Eck}}$			
112	62	129									$n_{2 \text{ th}}$			
											M_2			
											c	0.43	321	34.708
											$n_{2 \text{ Eck}}$			
											$n_{2 \text{ th}}$			
246	445	363									M_2			
1.6	1	1									c	0.43	450	34.708
102	56	117									$n_{2 \text{ Eck}}$			
102	56	114									$n_{2 \text{ th}}$			
											M_2			
											c	0.28	302	40.741
											$n_{2 \text{ Eck}}$			
											$n_{2 \text{ th}}$			
											M_2			
											c	0.28	447	40.741
											$n_{2 \text{ Eck}}$			
											$n_{2 \text{ th}}$			
											M_2			
											c	0.27	333	44.917
											$n_{2 \text{ Eck}}$			
											$n_{2 \text{ th}}$			
											M_2			
											c	0.27	450	44.917
											$n_{2 \text{ Eck}}$			
											$n_{2 \text{ th}}$			
											M_2			
											c	0.21	306	49.444
											$n_{2 \text{ Eck}}$			
											$n_{2 \text{ th}}$			

$M \dots$ [Nm]
 $n \dots$ [min^{-1}]
 $J \dots$ [kgcm^2]

$P \dots$ [kW]
 $I \dots$ [A]
 i [-]
 c [-]

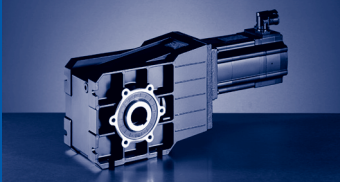

GKR [Nm]

GKR□□-2S (MCS)

$M_{2GN} \leq 450 \text{ Nm}$

GKR06-2S				06FC41	06IC41	09DC41	09FC38	09HC41	09LC41	12DC20	12DC41	12HC15	12HC30
				...500	...500	...500	...500	...500	...500	...500	...500	...500	...500
i	M_{2GN}	J_G	M_1	1.2	1.5	2.3	3.1	3.8	4.5	5.5	4.3	10	8
			n_1	4050	4050	4050	3750	4050	4050	1950	4050	1500	3000
			I_{M230}	2.9	3.2	4.6	5	6.8	8.4	5.2	8.8	7.6	10.5
			I_{M400}	1.5	1.6	2.3	2.5	3.4	4.2	2.6	4.5	3.8	
			P_N	0.51	0.64	1	1.2	1.6	1.9	1.1	1.8	1.6	2.5
			J_M	0.25	0.33	1.13	1.53	1.93	2.83	4.12	4.12	7.42	7.42
49.444	450	0.21	M_2			105	143	176	209				
			c			3.8	2.9	2.3	1.9				
			$n_{2 \text{ Eck}}$			82	76	82	82				
			$n_{2 \text{ th}}$			82	76	82	82				
54.513	337	0.2	M_2	60	75								
			c	4.9	3.9								
			$n_{2 \text{ Eck}}$	74	74								
			$n_{2 \text{ th}}$	74	74								
54.513	450	0.2	M_2			116	158	195	231				
			c			3.4	2.6	2.1	1.8				
			$n_{2 \text{ Eck}}$			74	69	74	74				
			$n_{2 \text{ th}}$			74	69	74	74				
62.5	302	0.13	M_2	69	87								
			c	3.8	3.1								
			$n_{2 \text{ Eck}}$	65	65								
			$n_{2 \text{ th}}$	65	65								
68.906	333	0.13	M_2	76	96								
			c	3.8	3.1								
			$n_{2 \text{ Eck}}$	59	59								
			$n_{2 \text{ th}}$	59	59								

M ... [Nm]
n ... [min^{-1}]
J ... [kgcm^2]

P ... [kW]
I ... [A]
i [-]
c [-]

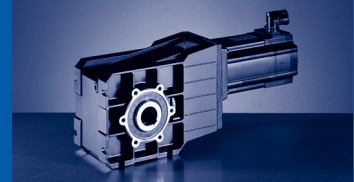

$M_{2GN} \leq 450 \text{ Nm}$

12HC35	12LC20	12LC41	14DC15	14DC36	14HC15	14HC32	14LC15	14LC32	14PC14	14PC32	GKR06-2S			
...S00	...S00	...S00	...S00	...S00	...S00	...S00	...S00	...S00	...S00	...S00	M_1	J_G	M_{2GN}	i
7.5	13.5	11	9.2	7.5	16	14	23	17.2	30	21	n_1			
3525	1950	4050	1500	3600	1500	3225	1500	3225	1350	3225	I_{M230}			
	11.8										I_{M400}			
5.7	5.9	10.2	4.5	7.5	6.6	11.9	9.7	15	10.8	15.6	P_N			
2.8	2.8	4.7	1.45	2.8	2.5	4.7	3.6	5.8	4.2	7.1	J_M			
7.42	10.72	10.72	8.22	8.22	14.32	14.32	23.44	23.44	34.74	34.82	M_2			
											c			
											$n_{2 \text{ Eck}}$	0.21	450	49.444
											$n_{2 \text{ th}}$			
											M_2			
											c			
											$n_{2 \text{ Eck}}$	0.2	337	54.513
											$n_{2 \text{ th}}$			
											M_2			
											c			
											$n_{2 \text{ Eck}}$	0.2	450	54.513
											$n_{2 \text{ th}}$			
											M_2			
											c			
											$n_{2 \text{ Eck}}$	0.13	302	62.5
											$n_{2 \text{ th}}$			
											M_2			
											c			
											$n_{2 \text{ Eck}}$	0.13	333	68.906
											$n_{2 \text{ th}}$			

$M \dots$ [Nm]
 $n \dots$ [min^{-1}]
 $J \dots$ [kgcm^2]

$P \dots$ [kW]
 $I \dots$ [A]
 i [-]
 c [-]

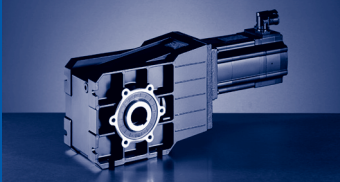

GKR [Nm]

GKR□□-2A (MCA)

$M_{2GN} \leq 90 \text{ Nm}$

GKR04-2A				10IC40	13IC34	13IC41
				...S00	...F10	...S00
i	M_{2GN}	J_G	M_1			
			n_1	2	6.3	4
			I_{M400}	3950	3410	4050
			P_N	2.4	6	4.4
			J_M	0.8	2.2	1.7
			M_2	2.44	8.34	8.34
5.185	69	0.81	c	9	31	19
			n_2 Eck	5.1	1.7	2.5
			n_2 th	762	658	781
				697	533	611
5.963	72	0.72	M_2	11	35	22
			c	4.6	1.5	2.3
			n_2 Eck	662	572	679
			n_2 th	597	441	521
7.111	78	0.45	M_2	13	42	27
			c	4.2	1.4	2.1
			n_2 Eck	556	480	570
			n_2 th	543	404	480
8.178	81	0.41	M_2	15	49	31
			c	3.8	1.3	1.9
			n_2 Eck	483	417	495
			n_2 th	465	337	404
9.101	84	3.27	M_2	17	54	34
			c	3.5	1.2	1.8
			n_2 Eck	434	375	445
			n_2 th	434	342	414
10.466	89	0.3	M_2	19	63	40
			c	3.2	1.1	1.6
			n_2 Eck	377	326	387
			n_2 th	377	286	343
11.449	90	0.26	M_2	21		43
			c	3		1.5
			n_2 Eck	345		354
			n_2 th	345		316
12.698	90	1.99	M_2	24		48
			c	2.7		1.3
			n_2 Eck	311		319
			n_2 th	311		312
14.603	90	0.18	M_2	27		55
			c	2.4		1.2
			n_2 Eck	271		277
			n_2 th	270		258
15.556	90	1.47	M_2	29		59
			c	2.2		1.1
			n_2 Eck	254		260
			n_2 th	254		260
17.889	90	0.14	M_2	34		
			c	1.9		
			n_2 Eck	221		
			n_2 th	221		
19.556	90	0.1	M_2	37		
			c	1.8		
			n_2 Eck	202		
			n_2 th	202		
22.489	90	0.09	M_2	42		
			c	1.5		
			n_2 Eck	176		
			n_2 th	176		

M ... [Nm]
 n ... [min⁻¹]
 J ... [kgcm²]

P ... [kW]
 I ... [A]
 i [-]
 c [-]

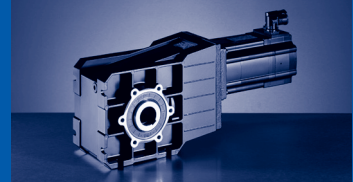

$M_{2GN} \leq 90 \text{ Nm}$

GKR04-2A				10IC40	13IC34	13IC41
				...S00	...F10	...S00
i	M_{2GN}	J_G	M_1	2	6.3	4
			n_1	3950	3410	4050
			I_{M400}	2.4	6	4.4
			P_N	0.8	2.2	1.7
			J_M	2.44	8.34	8.34
25.185	90	0.07	M_2	48		
			c	1.6		
			$n_{2 \text{ Eck}}$	157		
			$n_{2 \text{ th}}$	157		
28.963	90	0.06	M_2	55		
			c	1.4		
			$n_{2 \text{ Eck}}$	136		
			$n_{2 \text{ th}}$	136		

M ... [Nm]
n ... [min^{-1}]
J ... [kgcm^2]

P ... [kW]
I ... [A]
i [-]
c [-]

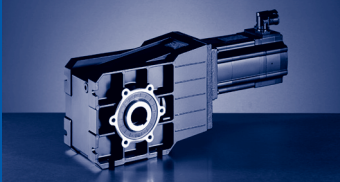

GKR [Nm]

GKR□□-2A (MCA)

$M_{2GN} \leq 240 \text{ Nm}$

GKR05-2A				10IC40	13IC34	13IC41	14LC16	14LC20	14LC35	14LC41
				...500	...F10	...500	...F10	...500	...F10	...500
i	M_{2GN}	J_G	M_1	2	6.3	4	12	6.7	10.8	5.4
			n_1	3950	3410	4050	1635	2000	3455	4100
			I_{M400}	2.4	6	4.4	4.8	3.3	9.1	5.8
			P_N	0.8	2.2	1.7	2.1	1.4	3.9	2.3
			J_M	2.44	8.34	8.34	19.32	19.24	19.24	19.24
3.565	138	4.95	M_2		20		40	22	36	17
			c		4.9		3.3	5.5	2.9	5.4
			n_2 Eck		957		459	561	969	1150
			n_2 th		843		459	561	757	858
4.889	147	2.79	M_2		28	18	55	30	50	24
			c		3.8	5.7	2.6	4.3	2.2	4.2
			n_2 Eck		698	828	334	409	707	839
			n_2 th		687	739	334	409	616	699
6.257	156	1.79	M_2		37	23	70	39	64	31
			c		3.2	4.7	2.1	3.6	1.8	3.5
			n_2 Eck		545	647	261	320	552	655
			n_2 th		545	608	261	320	501	574
6.883	179	2.57	M_2		40	25	77	43	70	34
			c		3.3	4.9	2.2	3.7	1.9	3.6
			n_2 Eck		495	588	238	291	502	596
			n_2 th		404	437	238	291	356	412
7.817	187	2.32	M_2		46	29	88	48	80	39
			c		3	4.5	2	3.4	1.8	3.3
			n_2 Eck		436	518	209	256	442	525
			n_2 th		350	379	209	256	299	356
9.44	191	1.53	M_2		56	35	107	59	96	48
			c		2.6	3.8	1.7	2.9	1.5	2.8
			n_2 Eck		361	429	173	212	366	434
			n_2 th		329	356	173	212	266	335
10.72	204	1.4	M_2		63	40	121	67	110	54
			c		2.4	3.6	1.6	2.7	1.4	2.7
			n_2 Eck		318	378	153	187	322	383
			n_2 th		286	310	153	187	227	292
12.081	208	1.02	M_2		71	45	137	76	124	61
			c		2.2	3.3	1.5	2.5	1.3	2.4
			n_2 Eck		282	335	135	166	286	339
			n_2 th		274	295	135	166	218	279
13.216	214	0.87	M_2		78	49	150	83	135	67
			c		2.1	3.1	1.4	2.3	1.2	2.3
			n_2 Eck		258	307	124	151	261	310
			n_2 th		258	277	124	151	204	262
13.719	217	0.94	M_2		81	51	156	86	141	69
			c		2	3	1.4	2.3	1.2	2.2
			n_2 Eck		249	295	119	146	252	299
			n_2 th		238	256	119	146	185	242
15.008	223	0.81	M_2	27	89	56	171	94	154	76
			c	5.7	1.9	2.8	1.3	2.1	1.1	2.1
			n_2 Eck	263	227	270	109	133	230	273
			n_2 th	263	221	240	109	133	174	227
16.857	240	0.6	M_2	31	100	63	192	106	173	86
			c	5.4	1.8	2.7	1.2	2	1.1	2
			n_2 Eck	234	202	240	97	119	205	243
			n_2 th	234	202	240	97	119	178	213
19.143	240	0.55	M_2	35	114	72	218	121		97
			c	4.8	1.6	2.4	1.1	1.8		1.8
			n_2 Eck	206	178	212	85	105		214
			n_2 th	206	178	212	85	104		188

$M \dots$ [Nm]
 $n \dots$ [min^{-1}]
 $J \dots$ [kgcm^2]

$P \dots$ [kW]
 $I \dots$ [A]
 $i \dots$ [-]
 $c \dots$ [-]

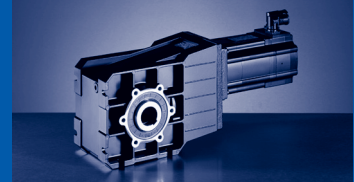

$M_{2GN} \leq 240 \text{ Nm}$

GKR05-2A				10IC40	13IC34	13IC41	14LC16	14LC20	14LC35	14LC41
				...S00	...F10	...S00	...F10	...S00	...F10	...S00
i	M_{2GN}	J_G	M_1	2	6.3	4	12	6.7	10.8	5.4
			n_1	3950	3410	4050	1635	2000	3455	4100
			I_{M400}	2.4	6	4.4	4.8	3.3	9.1	5.8
			P_N	0.8	2.2	1.7	2.1	1.4	3.9	2.3
			J_M	2.44	8.34	8.34	19.32	19.24	19.24	19.24
20.65	240	0.44	M_2	38	123	77		131		105
			c	4.4	1.5	2.2		1.7		1.6
			$n_{2 \text{ Eck}}$	191	165	196		97		199
			$n_{2 \text{ th}}$	191	165	196		97		174
23.45	240	0.41	M_2	43	140	88		149		120
			c	3.9	1.3	1.9		1.5		1.4
			$n_{2 \text{ Eck}}$	168	145	173		85		175
			$n_{2 \text{ th}}$	168	145	173		85		153
26.878	240	0.27	M_2	50	160	101				
			c	3.9	1.3	1.9				
			$n_{2 \text{ Eck}}$	147	127	151				
			$n_{2 \text{ th}}$	147	127	151				
30.522	240	0.25	M_2	57	182	115				
			c	3.4	1.1	1.7				
			$n_{2 \text{ Eck}}$	129	112	133				
			$n_{2 \text{ th}}$	129	112	133				
33.433	240	0.19	M_2	62	200	126				
			c	3.1	1	1.5				
			$n_{2 \text{ Eck}}$	118	102	121				
			$n_{2 \text{ th}}$	118	102	121				
37.967	240	0.18	M_2	71		144				
			c	2.7		1.4				
			$n_{2 \text{ Eck}}$	104		107				
			$n_{2 \text{ th}}$	104		107				
43.267	240	0.12	M_2	81						
			c	2.7						
			$n_{2 \text{ Eck}}$	91						
			$n_{2 \text{ th}}$	91						
49.133	240	0.11	M_2	92						
			c	2.4						
			$n_{2 \text{ Eck}}$	80						
			$n_{2 \text{ th}}$	80						
52.51	240	0.09	M_2	99						
			c	2.2						
			$n_{2 \text{ Eck}}$	75						
			$n_{2 \text{ th}}$	75						
59.63	240	0.08	M_2	112						
			c	1.9						
			$n_{2 \text{ Eck}}$	66						
			$n_{2 \text{ th}}$	66						

M ... [Nm]
n ... [min⁻¹]
J ... [kgcm²]

P ... [kW]
I ... [A]
i [-]
c [-]

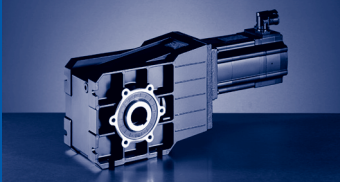

GKR [Nm]

GKR□□-2A (MCA)

$M_{2GN} \leq 450 \text{ Nm}$

GKR06-2A				10IC40	13IC34	13IC41	14LC16	14LC20	14LC35	14LC41	17NC17	17NC23	17NC35	17NC41	
				...S00	...F10	...S00	...F10	...S00	...F10	...S00	...F10	...S00	...F10	...S00	...F10
i	M_{2GN}	J_G	M_1	2	6.3	4	12	6.7	10.8	5.4	21.5	10.8	19	9.5	
			n_1	3950	3410	4050	1635	2000	3455	4100	1680	2300	3480	4110	
			I_{M400}	2.4	6	4.4	4.8	3.3	9.1	5.8	8.5	5.5	15.8	10.2	
			P_N	0.8	2.2	1.7	2.1	1.4	3.9	2.3	3.8	2.6	6.9	4.1	
			J_M	2.44	8.34	8.34	19.32	19.24	19.24	19.24	36.04	36.04	36.04	36.04	
3.431	200	9.58	M_2				37		34		69	34	61	30	
			c				5		4.3		2.8	4.9	2.4	4.6	
			$n_{2 \text{ Eck}}$				477		1007		490		670	1014	1198
			$n_{2 \text{ th}}$				476		722		490		670	638	733
4.706	250	5.61	M_2				52		47		95	47	84	41	
			c				4.5		3.9		2.5	4.5	2.2	4.2	
			$n_{2 \text{ Eck}}$				347		734		357		489	740	873
			$n_{2 \text{ th}}$				347		600		357		489	531	608
6.022	241	3.66	M_2		34										
			c		5.1										
			$n_{2 \text{ Eck}}$		566										
			$n_{2 \text{ th}}$		566										
6.022	280	3.66	M_2				67		60		121	60	108	53	
			c				4		3.4		2.2	3.9	2	3.7	
			$n_{2 \text{ Eck}}$				272		574		279		382	578	683
			$n_{2 \text{ th}}$				271		529		279		382	467	517
6.481	350	5.11	M_2				71		64		130	64	115	56	
			c				4.6		4		2.6	4.6	2.3	4.3	
			$n_{2 \text{ Eck}}$				252		533		259		355	537	634
			$n_{2 \text{ th}}$				252		376		259		355	332	382
7.146	348	4.54	M_2				79		71		144	71	128	63	
			c				4.2		3.6		2.3	4.1	2	3.9	
			$n_{2 \text{ Eck}}$				229		484		235		322	487	575
			$n_{2 \text{ th}}$				229		334		235		322	294	339
8.889	408	3.23	M_2				98		89		179	88	159	78	
			c				3.9		3.4		2.2	3.9	1.9	3.6	
			$n_{2 \text{ Eck}}$				184		389		189		259	392	462
			$n_{2 \text{ th}}$				184		308		189		259	270	313
9.8	384	2.93	M_2				109	59	99	48	198	98	176	86	
			c				3.3	5.6	2.9	5.5	1.9	3.3	1.6	3.1	
			$n_{2 \text{ Eck}}$				167	204	353	418	171	235	355	419	
			$n_{2 \text{ th}}$				167	204	270	307	171	235	223	274	
11.376	436	2.21	M_2		65		127	69	114	56	230	114	204	100	
			c		4.9		3.3	5.5	2.8	5.3	1.8	3.2	1.6	3	
			$n_{2 \text{ Eck}}$		300		144	176	304	360	148	202	306	361	
			$n_{2 \text{ th}}$		300		144	176	269	305	148	202	220	273	
12.444	450	1.89	M_2		72		139	76	125	61	252	125	223	110	
			c		4.6		3.1	5.2	2.7	5	1.7	3.1	1.5	2.9	
			$n_{2 \text{ Eck}}$		274		131	161	278	330	135	185	280	330	
			$n_{2 \text{ th}}$		274		131	161	252	284	135	185	204	250	
13.72	426	1.73	M_2		80	49	154	84	139	68	279	138	247	122	
			c		4	5.9	2.7	4.4	2.3	4.3	1.5	2.6	1.3	2.5	
			$n_{2 \text{ Eck}}$		249	295	119	146	252	299	123	168	254	300	
			$n_{2 \text{ th}}$		247	265	119	146	221	251	122	168	171	225	
15.873	450	1.32	M_2		92	58	178	98	161	79	323	160	286	141	
			c		3.6	5.4	2.4	4.1	2.1	4	1.3	2.4	1.2	2.3	
			$n_{2 \text{ Eck}}$		215	255	103	126	218	258	106	145	219	259	
			$n_{2 \text{ th}}$		215	247	103	126	209	226	106	145	163	196	
17.5	450	1.23	M_2		102	64	197	108	178	87	357	177	316	156	
			c		3.3	4.9	2.2	3.7	1.9	3.6	1.2	2.2	1.1	2	
			$n_{2 \text{ Eck}}$		195	231	93	114	197	234	96	131	199	235	
			$n_{2 \text{ th}}$		195	221	93	114	184	205	96	131	142	178	

$M \dots$ [Nm]
 $n \dots$ [min^{-1}]
 $J \dots$ [kgcm^2]

$P \dots$ [kW]
 $I \dots$ [A]
 $i \dots$ [-]
 $c \dots$ [-]

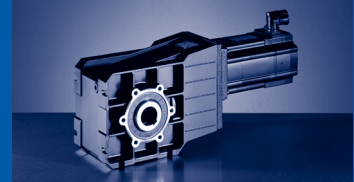

$M_{2GN} \leq 450 \text{ Nm}$

GKR06-2A				10IC40	13IC34	13IC41	14LC16	14LC20	14LC35	14LC41	17NC17	17NC23	17NC35	17NC41
				...S00	...F10	...S00	...F10	...S00	...F10	...S00	...F10	...S00	...F10	...S00
i	M_{2GN}	J_G	M_1	2	6.3	4	12	6.7	10.8	5.4	21.5	10.8	19	9.5
			n_1	3950	3410	4050	1635	2000	3455	4100	1680	2300	3480	4110
			I_{M400}	2.4	6	4.4	4.8	3.3	9.1	5.8	8.5	5.5	15.8	10.2
			P_N	0.8	2.2	1.7	2.1	1.4	3.9	2.3	3.8	2.6	6.9	4.1
			J_M	2.44	8.34	8.34	19.32	19.24	19.24	19.24	36.04	36.04	36.04	36.04
19.444	450	0.99	M_2		114	71	219	121	198	97	397	198		174
			c		2.9	4.4	2	3.3	1.7	3.2	1.1	2		1.8
			$n_{2 \text{ Eck}}$		175	208	84	103	178	211	86	118		211
			$n_{2 \text{ th}}$		175	208	84	103	178	185	86	118		160
21.438	450	0.93	M_2		126	79	242	134	219	108		218		192
			c		2.7	4	1.8	3	1.6	2.9		1.8		1.7
			$n_{2 \text{ Eck}}$		159	189	76	93	161	191		107		192
			$n_{2 \text{ th}}$		159	189	76	93	159	167		107		145
25.309	450	0.63	M_2		149	93	287	158	258	127				
			c		2.6	3.8	1.6	2.8	1.5	2.8				
			$n_{2 \text{ Eck}}$		135	160	65	79	137	162				
			$n_{2 \text{ th}}$		135	160	65	79	137	142				
27.903	450	0.59	M_2		165	103	317	175	285	141				
			c		2.3	3.5	1.4	2.5	1.4	2.6				
			$n_{2 \text{ Eck}}$		122	145	59	72	124	147				
			$n_{2 \text{ th}}$		122	145	59	72	124	129				
31.481	450	0.46	M_2		186	117	358	198	322	159				
			c		2.1	3.1	1.3	2.3	1.2	2.3				
			$n_{2 \text{ Eck}}$		108	129	52	64	110	130				
			$n_{2 \text{ th}}$		108	129	52	64	110	114				
34.708	450	0.43	M_2	63	206	129	395	219	356	176				
			c	5.6	1.9	2.8	1.1	2	1.1	2.1				
			$n_{2 \text{ Eck}}$	114	98	117	47	58	100	118				
			$n_{2 \text{ th}}$	114	98	117	47	58	100	103				
40.741	450	0.28	M_2	74	242	152								
			c	5.3	1.8	2.6								
			$n_{2 \text{ Eck}}$	97	84	99								
			$n_{2 \text{ th}}$	97	84	99								
44.917	450	0.27	M_2	82	267	168								
			c	4.8	1.6	2.4								
			$n_{2 \text{ Eck}}$	88	76	90								
			$n_{2 \text{ th}}$	88	76	90								
49.444	450	0.21	M_2	91	295	186								
			c	4.4	1.5	2.2								
			$n_{2 \text{ Eck}}$	80	69	82								
			$n_{2 \text{ th}}$	80	69	82								
54.513	450	0.2	M_2	100	325	205								
			c	4	1.3	2								
			$n_{2 \text{ Eck}}$	73	63	74								
			$n_{2 \text{ th}}$	72	63	74								
62.5	378	0.13	M_2	116										
			c	2.9										
			$n_{2 \text{ Eck}}$	63										
			$n_{2 \text{ th}}$	63										
68.906	417	0.13	M_2	128										
			c	2.9										
			$n_{2 \text{ Eck}}$	57										
			$n_{2 \text{ th}}$	57										

$M \dots$ [Nm]
 $n \dots$ [min^{-1}]
 $J \dots$ [kgcm^2]

$P \dots$ [kW]
 $I \dots$ [A]
 i [-]
 c [-]

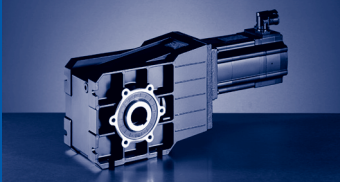

GKR [mm]

GKR□□-2S (MCS)

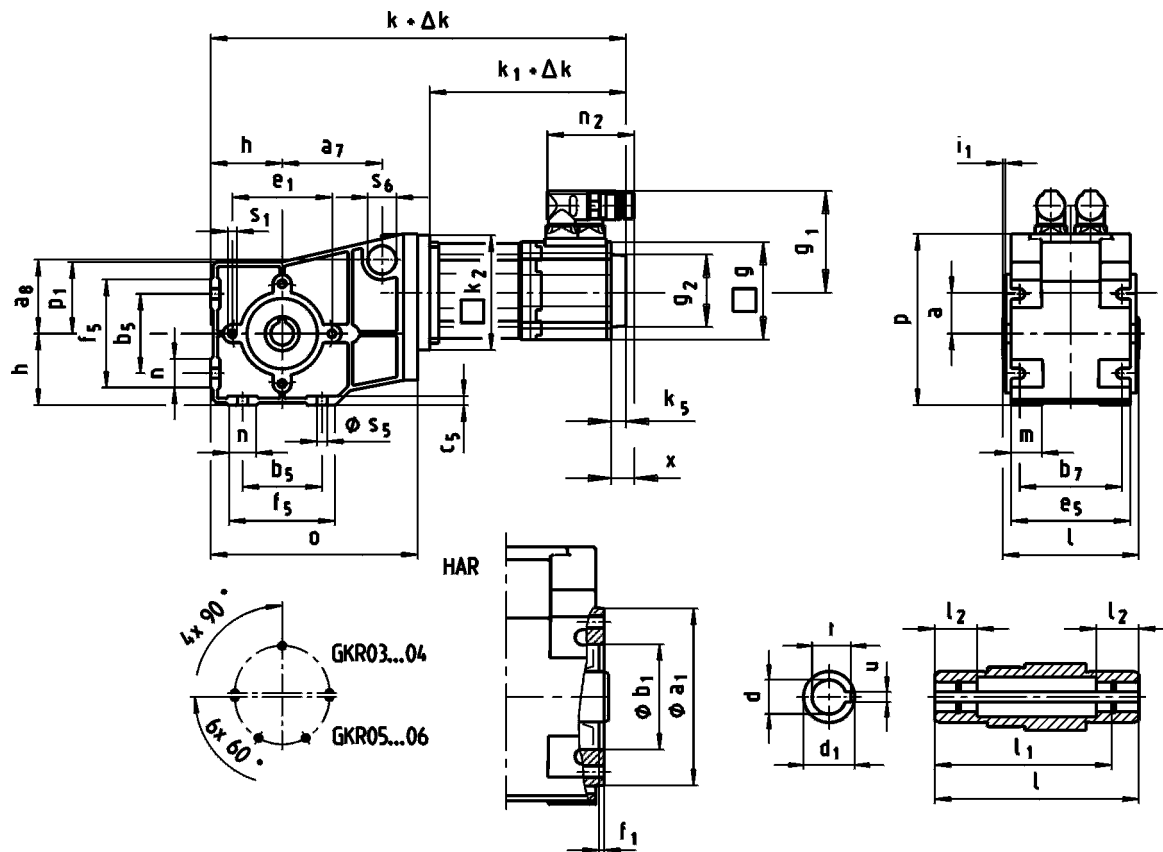

GKR□□-2S H□R ... RSO

		06C C41	06F C41	06I C41	09D C41	09F C38	09H C41	09L C41	12D C20	12D C41	12H C15	12H C30	12H C35	12L C20	12L C41	
GKR03...	k	294	324	354												
GKR04...	k	331	361	391	383	403	423	463								
GKR05...	k	384	414	444	437	457	477	517	454		494			534		
GKR06...	k	436	466	496	488	508	528	568	505		545			585		
...RSO B0 ¹⁾	Δk	0														
...RSO P□ ¹⁾	Δk	19				20										
	k_1	132	162	192	183	203	223	263	188		228			268		
	k_2	66			91				118				145 ²⁾			
...RSO	g	62				89				116						
	k_5	0				13				14						
	g_2	□ 62				Ø 67				Ø 72						
	g_1	76				90				105						
	n_2	64				78										
	x	21							18							

¹⁾ → 801 - SRS / SRM / ECN / EQN / EQI / C20

²⁾ GKR05: 12DC20 ... 12LC41

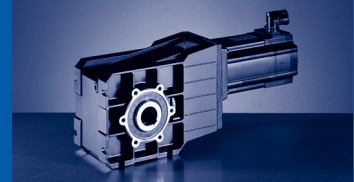

GKR□□-2S H□R ... RSO

		14D C15	14D C36	14H C15	14H C32	14L C15	14L C32	14P C14	14P C32
GKR06...	k	521		561		601		641	
...RSO B0 ¹⁾	Δ k	0							
...RSO P□ ¹⁾	Δ k	28							
	k ₁	201		241		281		321	
	k ₂	145							
	g	143							
...RSO	k ₅	24							
	g ₂	Ø 78							
	g ₁	116				147		116	147
	n ₂	78				94		78	94
	x	16				38		16	38

¹⁾ → 801 - SRS / SRM / ECN/ EQN / EQI / C20

GKR□□-2S H□R

	o	p	p ₁	h	a	a ₇	a ₈	s ₆
GKR03...	142	117	48	50	29	66	39	25x12
GKR04...	189	151	63	63	36	88	65	25x17
GKR05...	251	181	82	80	40	-	-	-
GKR06...	307	226	100	100	51	-	-	-

	b ₅	b ₇	c ₅	e ₅	f ₅	m	n	s ₅
GKR03...	60	75	7	90	80	22	20	6.6
GKR04...	70	90	8	105	95	28	25	9
GKR05...	100	100	11	115	138	27	48	
GKR06...	120	125	12	145	164	32	53	11

	d	l	d ₁	l ₁	l ₂	u	t	a ₁	b ₁	e ₁	f ₁	i ₁	s ₁
	H7					JS9	+0,2		J7				
GKR03...	18	100	30	85	22	6	20.8	85	55	70	2.5	2.5	M6x12
	20						22.8						
GKR04...	25	120	35	105	25	8	27 ²⁾	104	62	88	3	4	M8x16
	30						33.3						
GKR05...	35	143	50	127	30	10	38.3	116	80	100	4	4	M8x15
	40						43.3						
GKR06...	45	170	65	150	30	14	48.8	140	100	120	4	5	M10x22

²⁾ DIN 6885/3

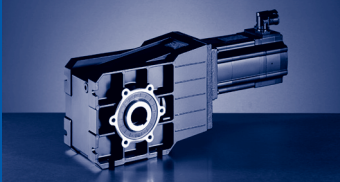

GKR [mm]

GKR□□-2S (MCS)

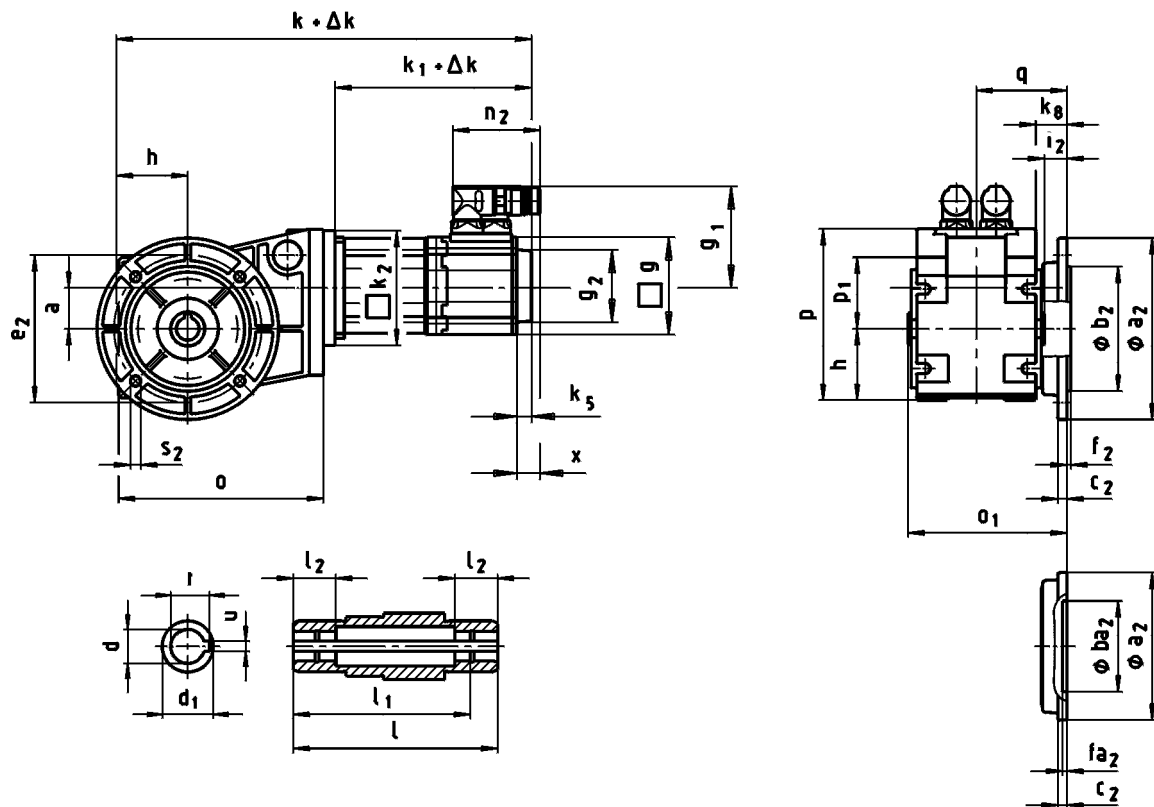

GKR□□-2S HAK ... RSO

		06C C41	06F C41	06I C41	09D C41	09F C38	09H C41	09L C41	12D C20	12D C41	12H C15	12H C30	12H C35	12L C20	12L C41	
GKR03...	k	294	324	354												
GKR04...	k	331	361	391	383	403	423	463								
GKR05...	k	384	414	444	437	457	477	517	454		494			534		
GKR06...	k	436	466	496	488	508	528	568	505		545			585		
...RSO B0 ¹⁾	Δk	0														
...RSO P□ ¹⁾	Δk	19				20										
...RSO	k_1	132	162	192	183	203	223	263	188		228				268	
	k_2	66			91							118		145 ²⁾		
	g	62			89							116				
	k_5	0			13							14				
	g_2	□ 62			Ø 67							Ø 72				
	g_1	76			90							105				
	n_2	64							78							
	x	21											18			

¹⁾ → 801 - SRS / SRM / ECN / EQN / EQI / C20

²⁾ GKR05: 12DC20 ... 12LC41

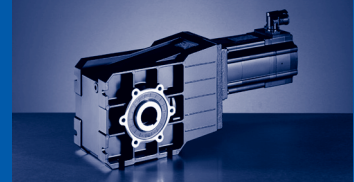

GKR□□-2S HAK ... RSO

		14D C15	14D C36	14H C15	14H C32	14L C15	14L C32	14P C14	14P C32
GKR06...	k	521		561		601		641	
...RSO B0 ¹⁾	Δ k	0							
...RSO P□ ¹⁾	Δ k	28							
	k ₁	201		241		281		321	
	k ₂	145							
	g	143							
...RSO	k ₅	24							
	g ₂	Ø 78							
	g ₁	116				147		116	147
	n ₂	78				94		78	94
	x	16				38		16	38

¹⁾ → 801 - SRS / SRM / ECN/ EQN / EQI / C20

GKR□□-2S HAK

	o	o ₁	p	p ₁	h	a	q	k ₈
GKR03...	142	130	117	48	50	29	80	35
GKR04...	189	140	151	63	63	36		28
GKR05...	251	177	181	82	80	40	105	48
GKR06...	307	212	226	100	100	51	126.5	54

	d	l	d ₁	l ₁	l ₂	u	t	a ₂	b ₂	ba ₂	c ₂	e ₂	f ₂	fa ₂	i ₂	s ₂
	H7					JS9	+0,2		j7	H7						4x90°
GKR03...	18	100	30	85	22	6	20.8	110	-	60	8	87	-	4	30	9
	20						100					3				7
GKR04...	25	120	35	105	25	8	27 ²⁾	160	110	-	12	130	3.5	-	20	9
	30						143					50				127
GKR05...	35	143	50	127	30	12	43.3	200	130	-	12	165	3.5	-	33.5	11
	40						170					65				150

²⁾ DIN 6885/3

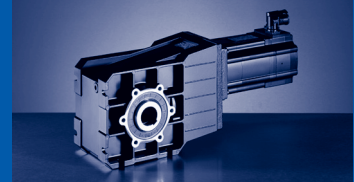

GKR□□-2S V□R ... RSO

		14D C15	14D C36	14H C15	14H C32	14L C15	14L C32	14P C14	14P C32
GKR06...	k	521		561		601		641	
...RSO B0 ¹⁾	Δ k	0							
...RSO P□ ¹⁾	Δ k	28							
	k ₁	201		241		281		321	
	k ₂	145							
	g	143							
...RSO	k ₅	24							
	g ₂	Ø 78							
	g ₁	116				147		116	147
	n ₂	78				94		78	94
	x	16				38		16	38

¹⁾ → 801 - SRS / SRM / ECN / EQN / EQI / C20

GKR□□-2S V□R

	o	o ₁	p	p ₁	h	a	q	a ₇	a ₈	s ₆
GKR03...	142	138	117	48	50	29	90	66	39	25x12
GKR04...	189	158	151	63	63	36	100	88	65	25x17
GKR05...	251	199	181	82	80	40	131.5	-	-	-
GKR06...	307	235	226	100	100	51	155	-	-	-

	b ₅	b ₇	c ₅	e ₅	f ₅	m	n	s ₅
GKR03...	60	75	7	90	80	22	20	6.6
GKR04...	70	90	8	105	95	28	25	9
GKR05...	100	100	11	115	138	27	48	
GKR06...	120	125	12	145	164	32	53	11

	d	l	d ₁	l ₁	l ₂	d ₂	u	t	a ₁	b ₁	e ₁	f ₁	i ₁	s ₁
GKR03...	20	40	30	5	28	M6	6	22.5	85	J7 55	70	2.5	42.5	M6x12
GKR04...									104	62	88	3		M8x16
GKR05...	30	60	50	6	45	M10	8	33	116	80	100	4	64	M8x15
GKR06...	35	70	65	7	56	M12	10	38	140	100	120	4	75	M10x22

d ≤ 50 mm: k6; d > 50 mm: m6

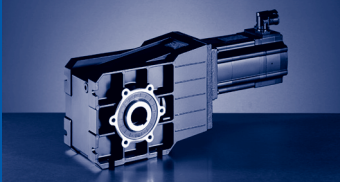

GKR [mm]

GKR□□-2S (MCS)

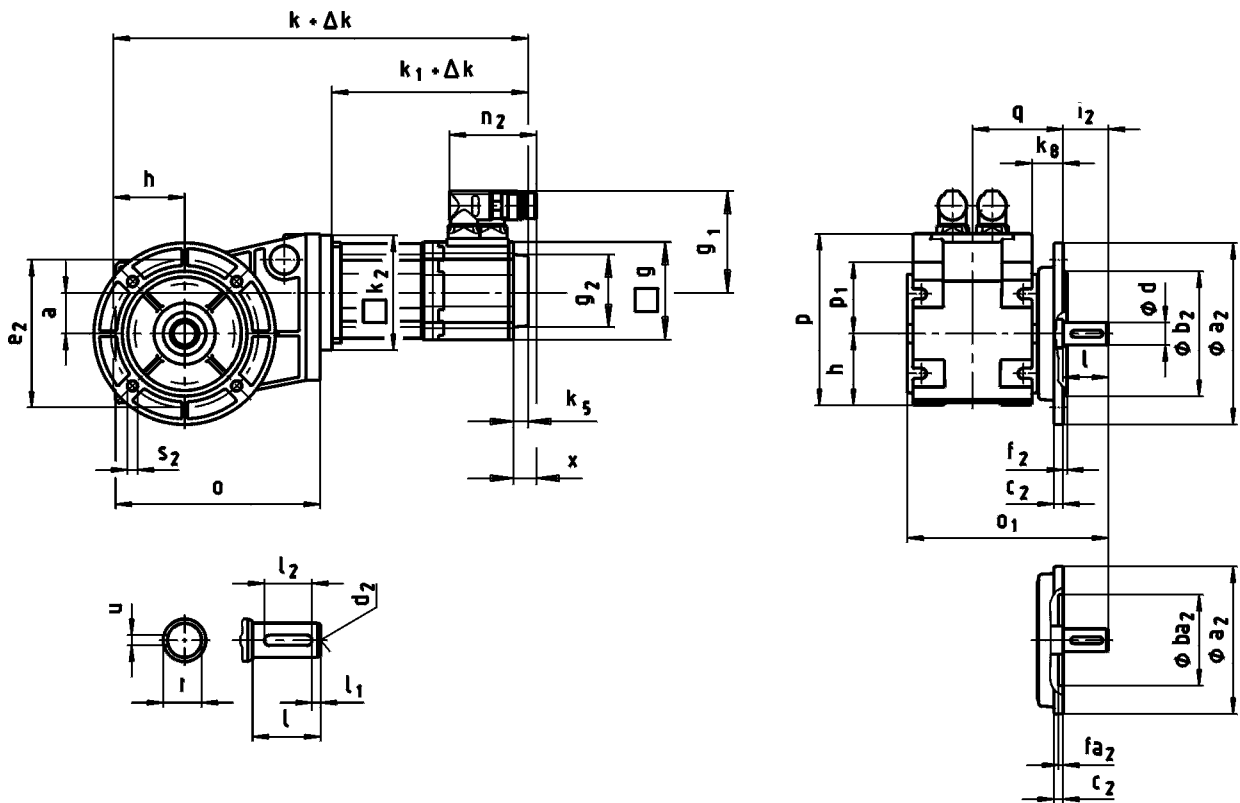

GKR□□-2S VAK ... RSO

		06C C41	06F C41	06I C41	09D C41	09F C38	09H C41	09L C41	12D C20	12D C41	12H C15	12H C30	12H C35	12L C20	12L C41
GKR03...	k	294	324	354											
GKR04...	k	331	361	391	383	403	423	463							
GKR05...	k	384	414	444	437	457	477	517	454			494			534
GKR06...	k	436	466	496	488	508	528	568	505			545			585
...RSO B0 ¹⁾	Δk	0													
...RSO P□ ¹⁾	Δk	19			20										
	k_1	132	162	192	183	203	223	263	188		228		268		
	k_2	66			91				118				145 ²⁾		
	g	62			89				116						
...RSO	k_5	0			13				14						
	g_2	□ 62			Ø 67				Ø 72						
	g_1	76			90				105						
	n_2	64							78						
	x				21								18		

¹⁾ → 801 - SRS / SRM / ECN / EQN / EQI / C20

²⁾ GKR05: 12DC20 ... 12LC41

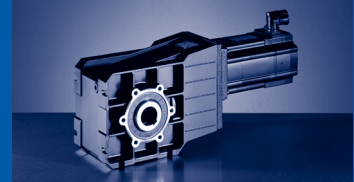

GKR□□-2S VAK ... RSO

		14D C15	14D C36	14H C15	14H C32	14L C15	14L C32	14P C14	14P C32
GKR06...	k	521		561		601		641	
...RSO B0 ¹⁾	Δ k	0							
...RSO P□ ¹⁾	Δ k	28							
	k ₁	201		241		281		321	
	k ₂	145							
	g	143							
...RSO	k ₅	24							
	g ₂	Ø 78							
	g ₁	116				147		116	147
	n ₂	78				94		78	94
	x	16				38		16	38

¹⁾ →  801 - SRS / SRM / ECN / EQN / EQI / C20

GKR□□-2S VAK

	o	o ₁	p	p ₁	h	a	q	k ₈
GKR03...	142	168	117	48	50	29	80	35
GKR04...	189	178	151	63	63	36	80.5	28
GKR05...	251	233	181	82	80	40	105	48
GKR06...	307	277	226	100	100	51	126.5	54

	d	l	l ₁	l ₂	d ₂	u	t	a ₂	b ₂	ba ₂	c ₂	e ₂	f ₂	fa ₂	i ₂	s ₂
									j7	H7						4x90°
GKR03...	20	40	5	28	M6	6	22.5	110	-	60	8	87	-	4	40	9
GKR04...								120	80	100		3	7			
GKR05...	30	60	6	45	M10	8	33	160	110	-	12	130	3.5	-	60	9
GKR06...								200	130	165		11				
	35	70	7	56	M12	10	38	250	180			215	4		70	14

d ≤ 50 mm: k6; d > 50 mm: m6

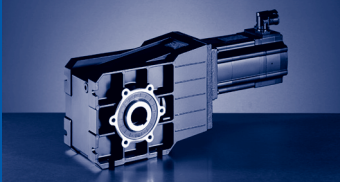

GKR [mm]

GKR□□-2A (MCA)

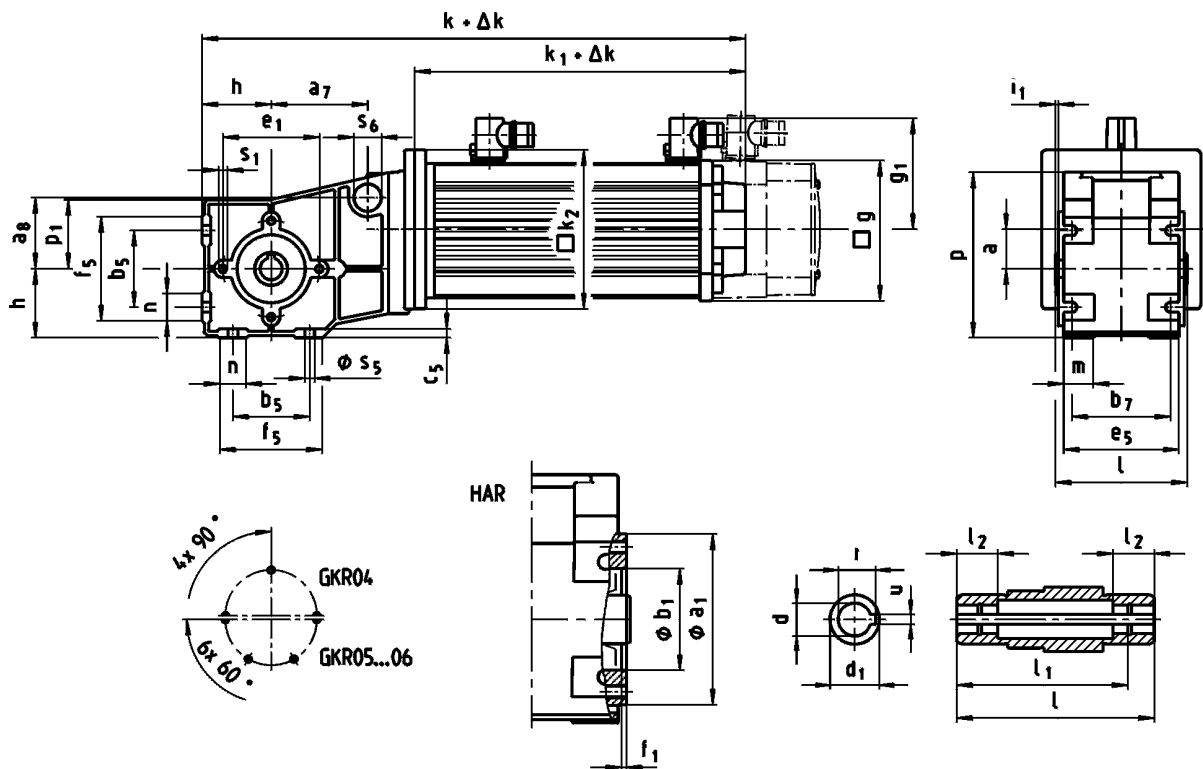

GKR□□-2A H□R ... RSO

		10I C40 ...S00	13I C41 ...S00	13I C34 ...F10	14L C20 ...S00	14L C41 ...S00	14L C16 ...F10	14L C35 ...F10	17N C23 ...S00	17N C41 ...S00	17N C17 ...F10	17N C35 ...F10
GKR04...	k	459	467	535								
GKR05...	k	512	521	589	571		633					
GKR06...	k	564	572	640	622		684	661		750		
...RSO B0 ¹⁾	Δ k	0										
...RSO P□ ¹⁾	Δ k	25	35			33				35		
	k ₁	258	267	335	307		369	346		435		
	k ₂	145				180						
	g	102	131			142			165			
	g ₁	90	102			109			118			

¹⁾ → 803 - SRS / SRM / ECN / EQN / EQI / S20 / T20 / CDD

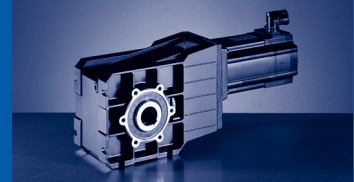

GKR□□-2A H□R

	o	p	p ₁	h	a	a ₇	a ₈	s ₆
GKR04...	189	151	63	63	36	88	65	25x17
GKR05...	251	181	82	80	40	-	-	-
GKR06...	307	226	100	100	51	-	-	-

	b ₅	b ₇	c ₅	e ₅	f ₅	m	n	s ₅
GKR04...	70	90	8	105	95	28	25	9
GKR05...	100	100	11	115	138	27	48	
GKR06...	120	125	12	145	164	32	53	11

	d	l	d ₁	l ₁	l ₂	u	t	a ₁	b ₁	e ₁	f ₁	i ₁	s ₁	
	H7					JS9	+0,2		J7					
GKR04...	20	120	30	105	25	6	22.8	104	62	88	3	2.5	M8x16	
	25		35			8	27 ¹⁾							
GKR05...	30	143	50	127		10	33.3	116	80	100		4	4	M8x15
	35					12	38.3							
GKR06...	40	170	65	150	30	43.3	140	100	120	5	5	M10x22		
	45				14	48.8								

¹⁾ DIN 6885/3

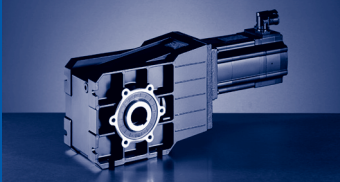

GKR [mm]

GKR□□-2A (MCA)

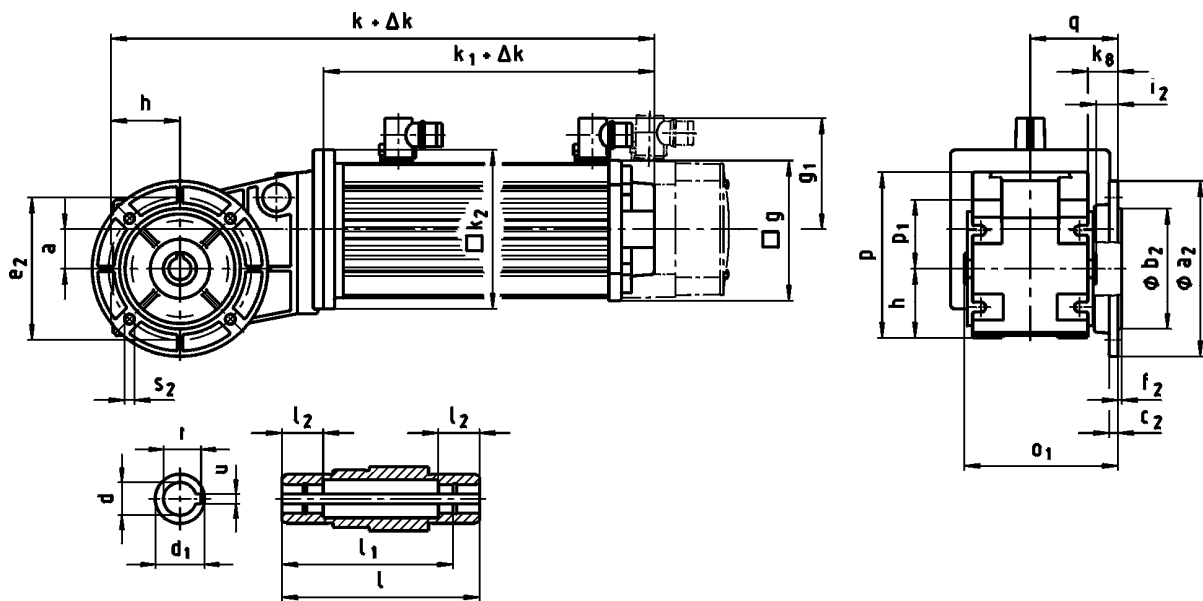

GKR□□-2A HAK ... RSO

		10I C40 ...S00	13I C41 ...S00	13I C34 ...F10	14L C20 ...S00	14L C41 ...S00	14L C16 ...F10	14L C35 ...F10	17N C23 ...S00	17N C41 ...S00	17N C17 ...F10	17N C35 ...F10
GKR04...	k	459	467	535								
GKR05...	k	512	521	589	571		633					
GKR06...	k	564	572	640	622		684	661		750		
...RSO B0 ¹⁾	Δk	0										
...RSO P□ ¹⁾	Δk	25	35		33				35			
	k_1	258	267	335	307		369	346		435		
	k_2	145					180					
	g	102	131			142			165			
	g_1	90	102			109			118			

¹⁾ → 803 - SRS / SRM / ECN / EQN / EQI / S20 / T20 / CDD

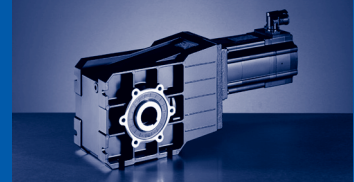

GKR□□-2A HAK

	o	o ₁	p	p ₁	h	a	q	k ₈
GKR04...	189	140	151	63	63	36	80	28
GKR05...	251	177	181	82	80	40	105	48
GKR06...	307	212	226	100	100	51	126.5	54

	d	l	d ₁	l ₁	l ₂	u	t	a ₂	b ₂	c ₂	e ₂	f ₂	i ₂	s ₂
	H7					JS9	+0,2		j7					4x90°
GKR04...	20	120	30	105	25	6	22.8	120	80	8	100	3	20	7
	25		35			8	27 ¹⁾							160
GKR05...	30	143	50	127	25	10	38.3	200	130	12	165	3.5	33.5	11
	35					12	43.3							250
GKR06...	40	170	65	150	30	14	48.8	250	180	12	165	3.5	33.5	11
	45					14	48.8	250	180	215	4	41.5	14	

¹⁾ DIN 6885/3

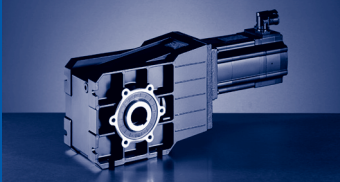

GKR [mm]

GKR□□-2A (MCA)

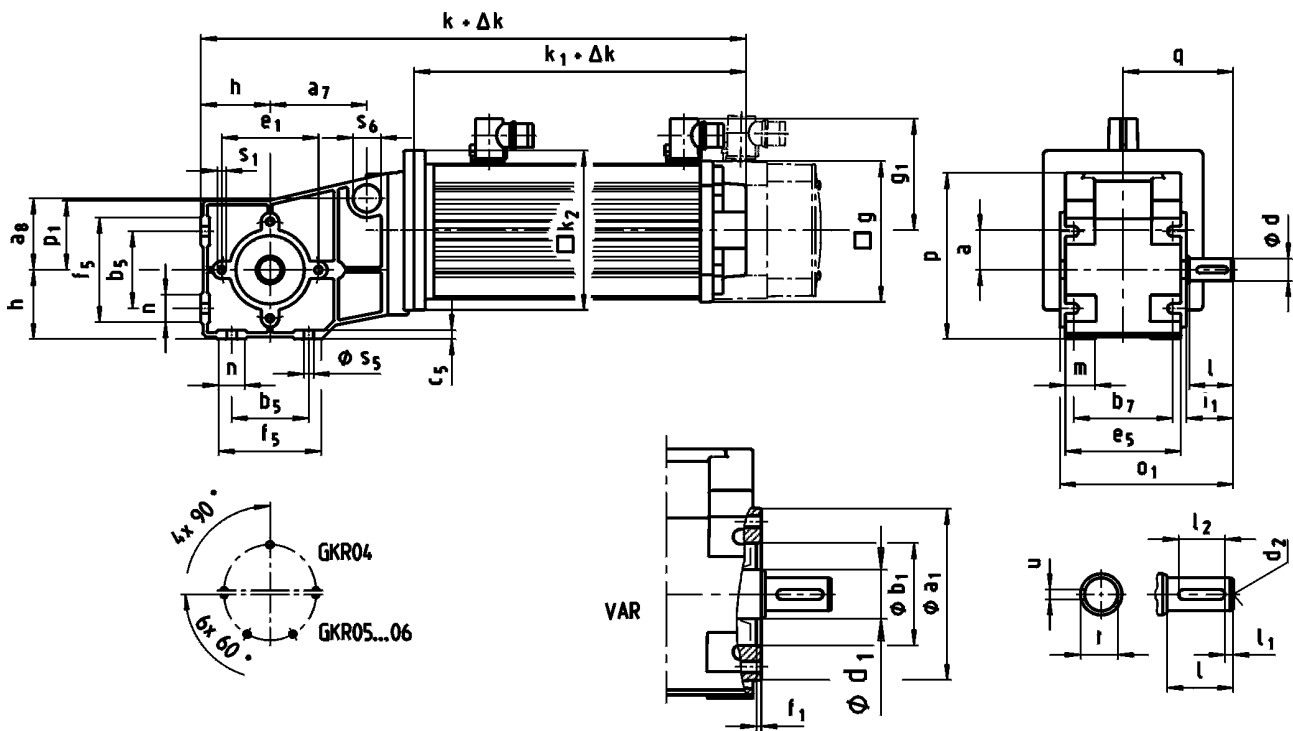

GKR□□-2A V□R ... RSO

		10L C40 ...S00	13L C41 ...S00	13L C34 ...F10	14L C20 ...S00	14L C41 ...S00	14L C16 ...F10	14L C35 ...F10	17N C23 ...S00	17N C41 ...S00	17N C17 ...F10	17N C35 ...F10
GKR04...	k	459	467	535								
GKR05...	k	512	521	589	571		633					
GKR06...	k	564	572	640	622		684	661		750		
...RSO B0 ¹⁾	Δk	0										
...RSO P□ ¹⁾	Δk	25	35			33				35		
	k_1	258	267	335	307		369		346		435	
	k_2	145					180					
	g	102	131			142				165		
	g_1	90	102			109				118		

¹⁾ → 803 - SRS / SRM / ECN / EQN / EQI / S20 / T20 / CDD

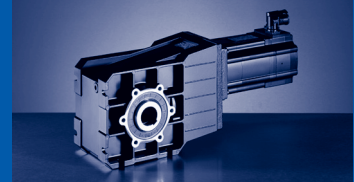

GKR□□-2A V□R

	o	o ₁	p	p ₁	h	a	q	a ₇	a ₈	s ₆
GKR04...	189	158	151	63	63	36	100	88	65	25x17
GKR05...	251	199	181	82	80	40	131.5	-	-	-
GKR06...	307	235	226	100	100	51	155	-	-	-

	b ₅	b ₇	c ₅	e ₅	f ₅	m	n	s ₅
GKR04...	70	90	8	105	95	28	25	9
GKR05...	100	100	11	115	138	27	48	
GKR06...	120	125	12	145	164	32	53	11

	d	l	d ₁	l ₁	l ₂	d ₂	u	t	a ₁	b ₁	e ₁	f ₁	i ₁	s ₁
										J7				
GKR04...	20	40	30	5	28	M6	6	22.5	104	62	88	3	42.5	M8x16
GKR05...	30	60	50	6	45	M10	8	33	116	80	100	4	64	M8x15
GKR06...	35	70	65	7	56	M12	10	38	140	100	120		75	M10x22

d ≤ 50 mm: k6; d > 50 mm: m6

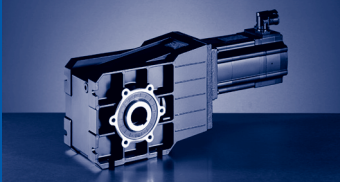

GKR [mm]

GKR□□-2A (MCA)

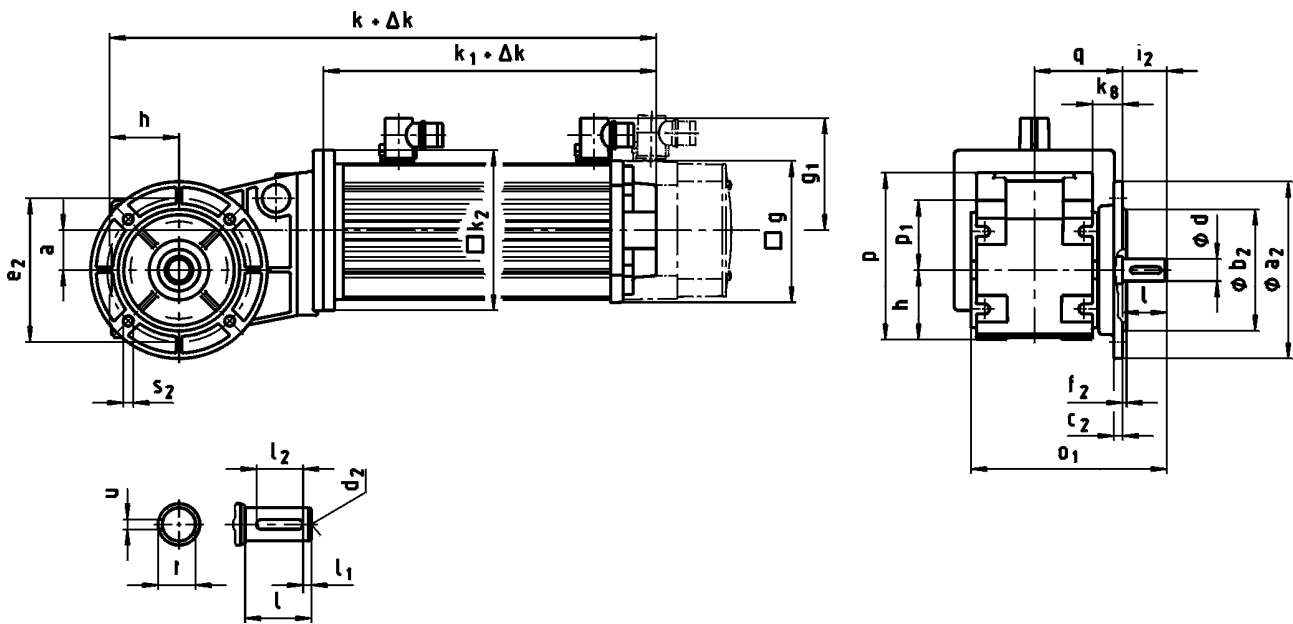

GKR□□-2A VAK ... RSO

		10I C40 ...S00	13I C41 ...S00	13I C34 ...F10	14L C20 ...S00	14L C41 ...S00	14L C16 ...F10	14L C35 ...F10	17N C23 ...S00	17N C41 ...S00	17N C17 ...F10	17N C35 ...F10
GKR04...	k	459	467	535								
GKR05...	k	512	521	589	571		633					
GKR06...	k	564	572	640	622		684	661			750	
...RSO B0 ¹⁾	Δk	0										
...RSO P□ ¹⁾	Δk	25	35			33				35		
	k_1	258	267	335	307		369		346		435	
	k_2	145					180					
	g	102	131			142				165		
	g ₁	90	102			109				118		

¹⁾ → 803 - SRS / SRM / ECN / EQN / EQI / S20 / T20 / CDD

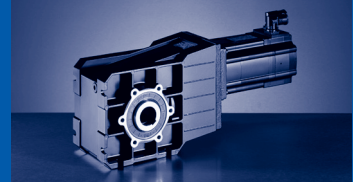

GKR□□-2A VAK

	o	o ₁	p	p ₁	h	a	q	k ₈
GKR04...	189	178	151	63	63	36	80.5	28
GKR05...	251	233	181	82	80	40	105	48
GKR06...	307	277	226	100	100	51	126.5	54

	d	l	l ₁	l ₂	d ₂	u	t	a ₂	b ₂	c ₂	e ₂	f ₂	i ₂	s ₂	
									j7					4x90°	
GKR04...	20	40	5	28	M6	6	22.5	120	80	8	100	3	40	7	
								160	110		130	3.5	60	9	
GKR05...	30	60	6	45	M10	8	33	200	130	12	165			70	11
GKR06...	35	70	7	56	M12	10	38	250	180		215				4

d ≤ 50 mm: k6; d > 50 mm: m6

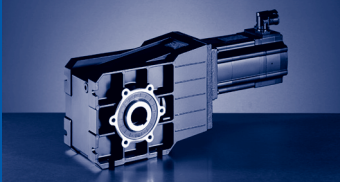

Hollow shaft with shrink disc

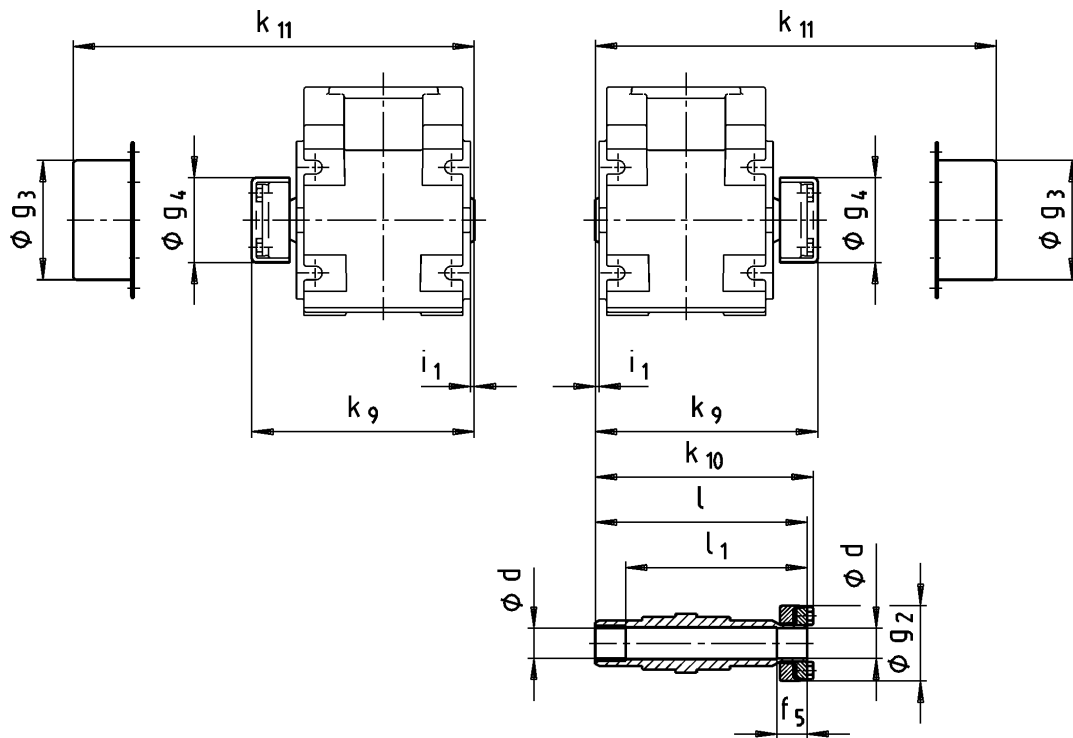

	Machine shaft	Hollow shaft with shrink disc						Protective cap		Cover	
	d	i ₁	k ₁₀	g ₂	l	l ₁	f ₅	k ₉	g ₄	k ₁₁	g ₃
	h6										
GKR03...	20	2.5	124	50	120	100	20	126	54	138	65
GKR04...			144		140	120		146		158	79
GKR05...	30 35	4	176.5	80	171	151	28	175.5	84	182	90
GKR06...	40	5	209.5	90	204	174	30	201.5	94	214	100

- ▶ Ensure that the strength of the shaft material is adequate in shrink disc designs.
When using typical steels (e.g. C45, 42CrMo4), the torques listed in the selection tables can be used without restriction. When using material that is considerably weaker, please consult us. Medium surface roughness Rz must not exceed 15 µm (turning operation is sufficient).

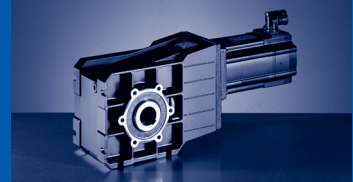

Hoseproof hollow shaft cover

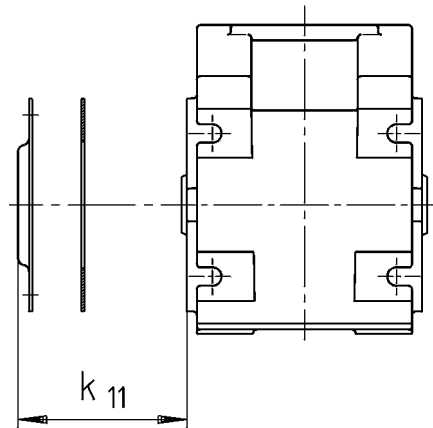

	Cover including seal
	k_{11}
GKR03...	9
GKR04...	10
GKR05...	11

Gearbox with 2nd output shaft end

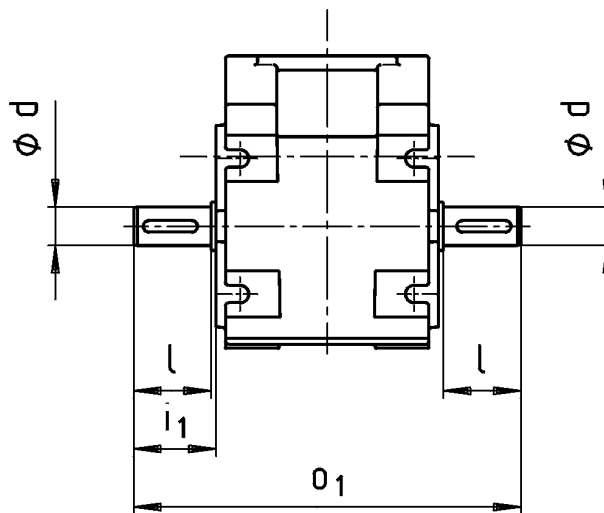

	d	l	i_1	o_1
GKR03...	20	40	42.5	180
GKR04...				200
GKR05...	30	60	64	263
GKR06...	35	70	75	310

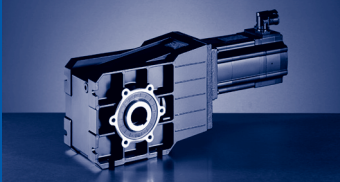

Rubber buffer for torque plate

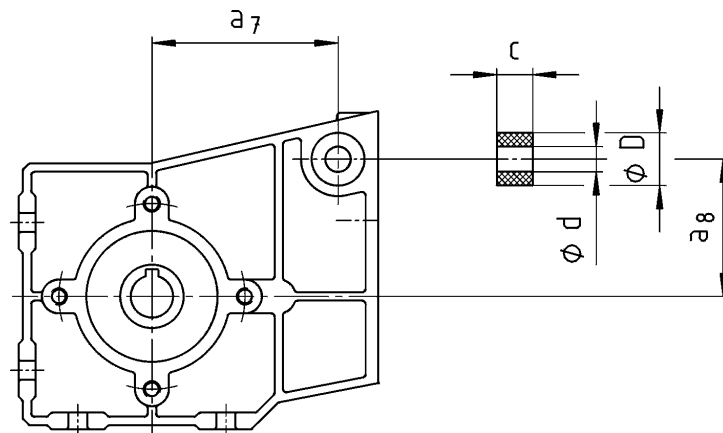

	d	D	c	a ₇	a ₈
GKR03...	10	25	13	66	39
GKR04...				88	65

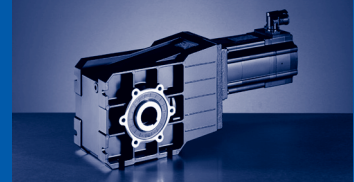

GKR03/04

Torque plate at threaded hole circle in position 3

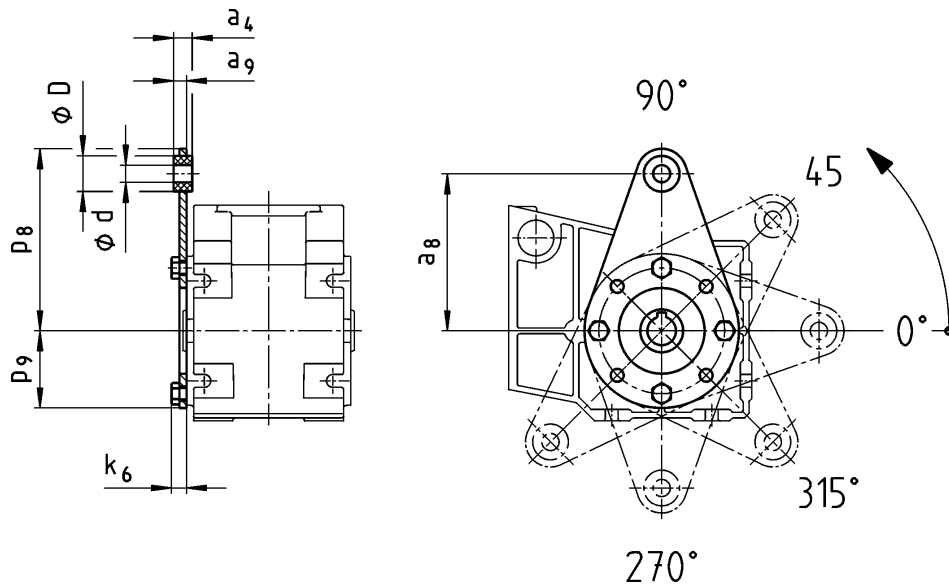

GKR03/04

Torque plate at threaded hole circle in position 5

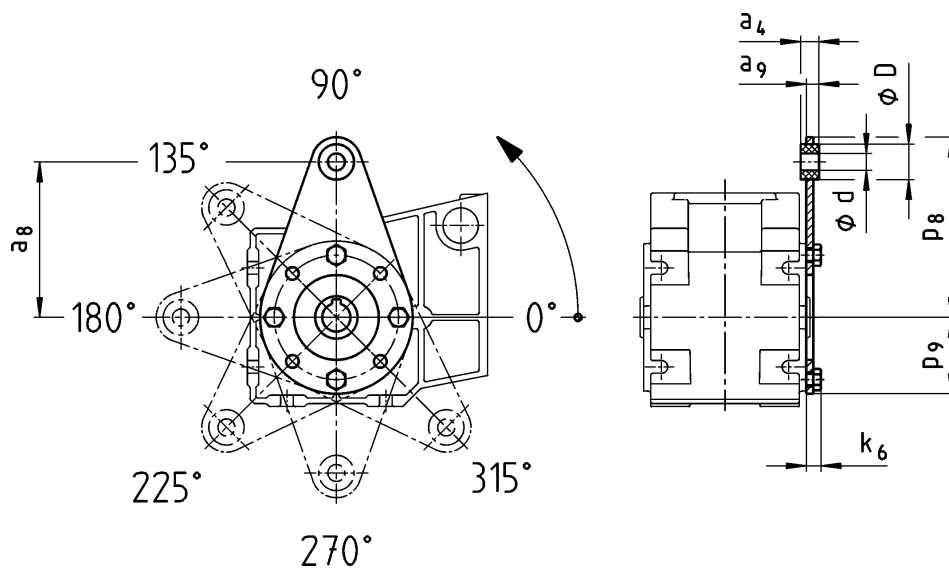

	a ₄	a ₈	a ₉	d	D	k ₆	p ₈	p ₉
GKR03...	12	100	8	8	20	9	115	42
GKR04...	13	110	9	10	25	11	128	54

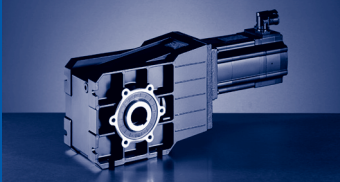

GKR & [mm]

GKR05/06

Torque plate at threaded hole circle in position 3

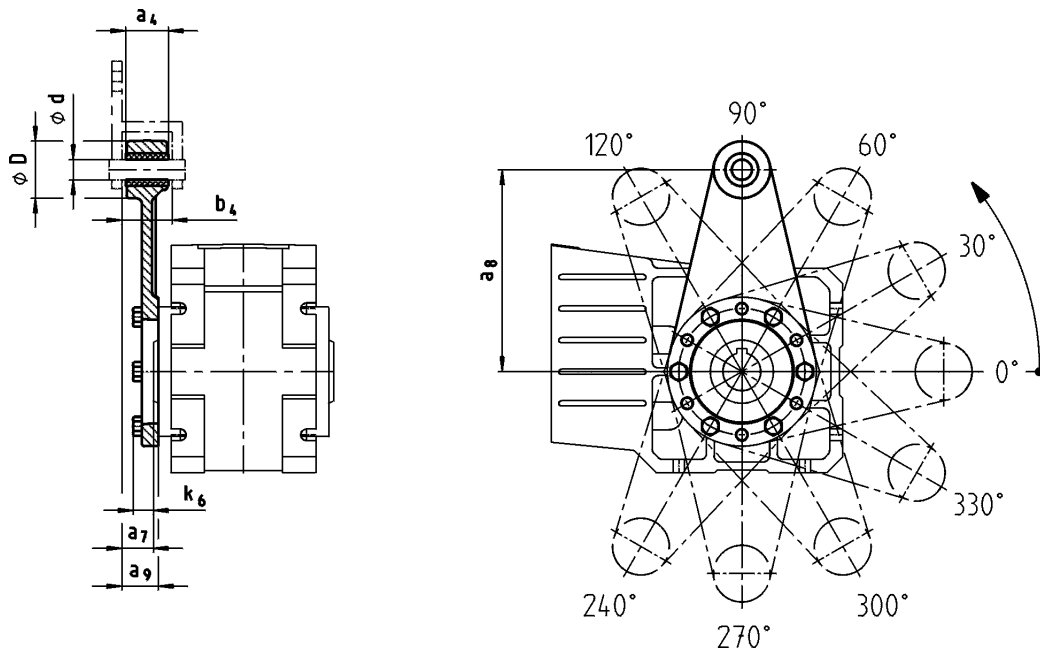

GKR05/06

Torque plate at threaded hole circle in position 5

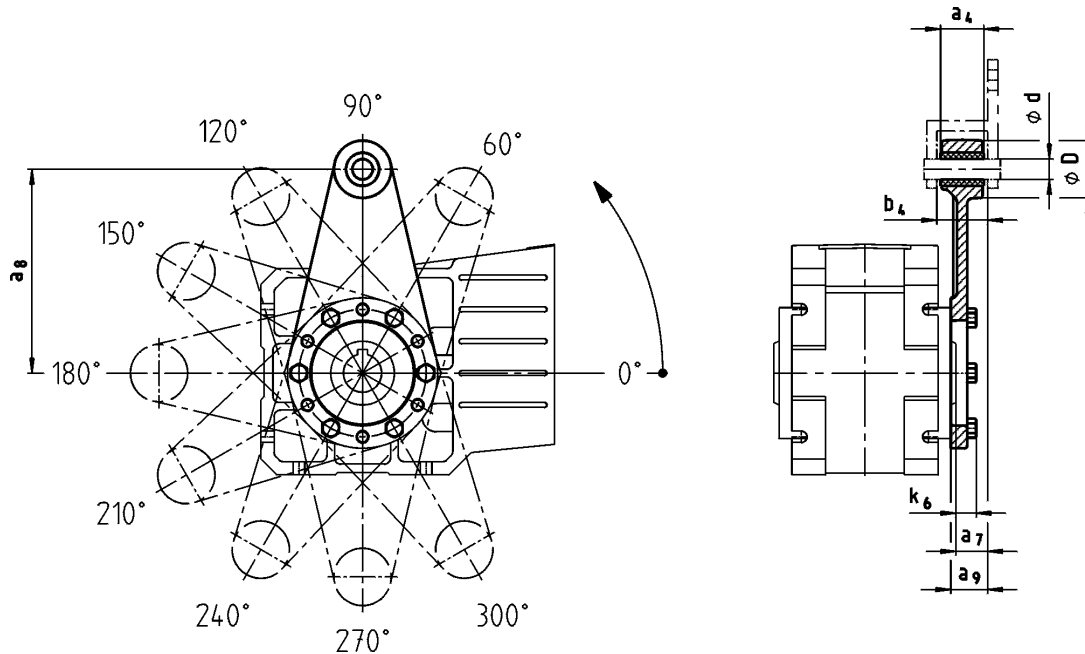

	Installation space							
	a ₇	b ₄	a ₄	a ₈	a ₉	d	D	k ₆
GKR05...	23.5	38.5	34	160	27.5	16	45	15
GKR06...	28	44.5	40	200	33	20	50	18

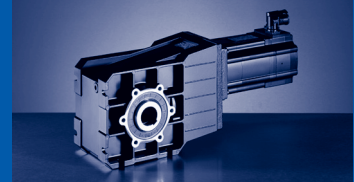

GKR05 / 06

Torque plate at casing foot in position 4 or 6

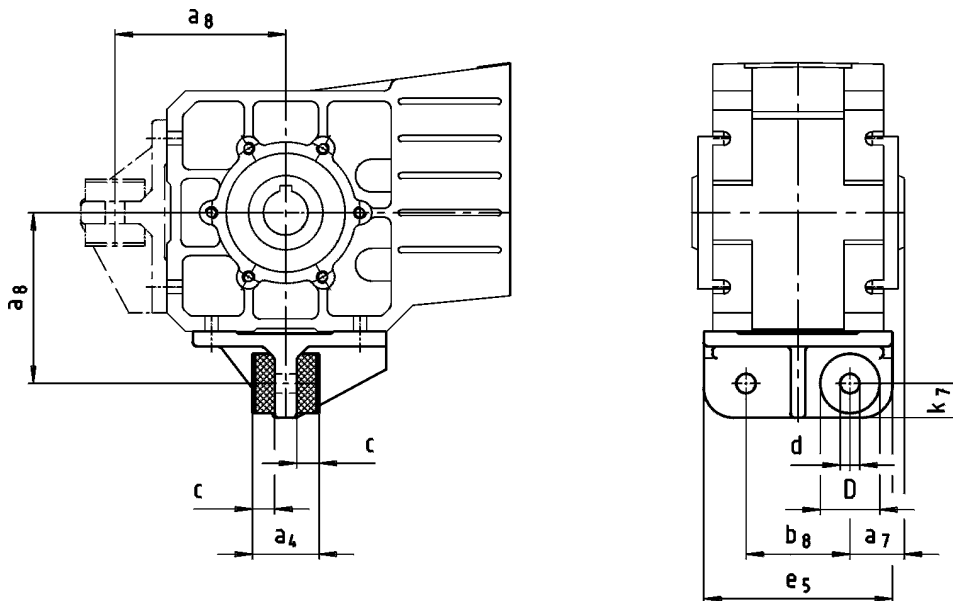

	a ₄	a ₇	a ₈	b ₈	c	d	D	e ₅	k ₇
GKR05...	45	36.5	115	70	15	13	40	127	25
GKR06...	72	45	145	80	27	17	50	145	28

Mounting set for hollow shaft circlip
Proposed design for auxiliary tools

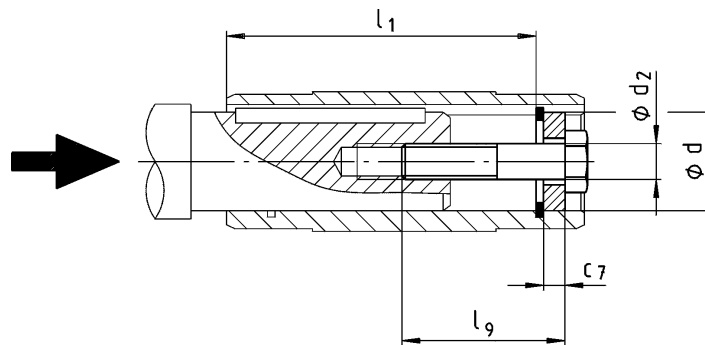

	Hollow shaft		Hollow shaft circlip mounting set (Assembly auxiliaries)		
	d	l ₁	d ₂	l ₉	c ₇
	H7				
GKR03...	18	85	M6	40	4
	20				
GKR04...	25	105	M10	50	5
	30				
GKR05...	35	127	M12	60	7
	40				
GKR06...	45	150	M16	60	9

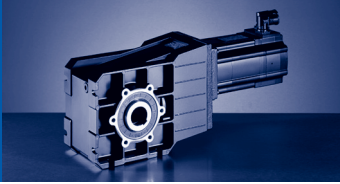

GKR & [mm]

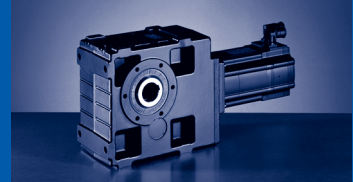

Permissible radial force

$$Fr_{zul} = \min(f_w \times f_{\alpha} \times Fr_{Tab}; f_w \times Fr_{max})$$

Permissible axial force

$$Fa_{zul} = Fa_{Tab} \text{ at } Fr = 0$$

At Fr and $Fa \neq 0$ please contact your Lenze sales office.

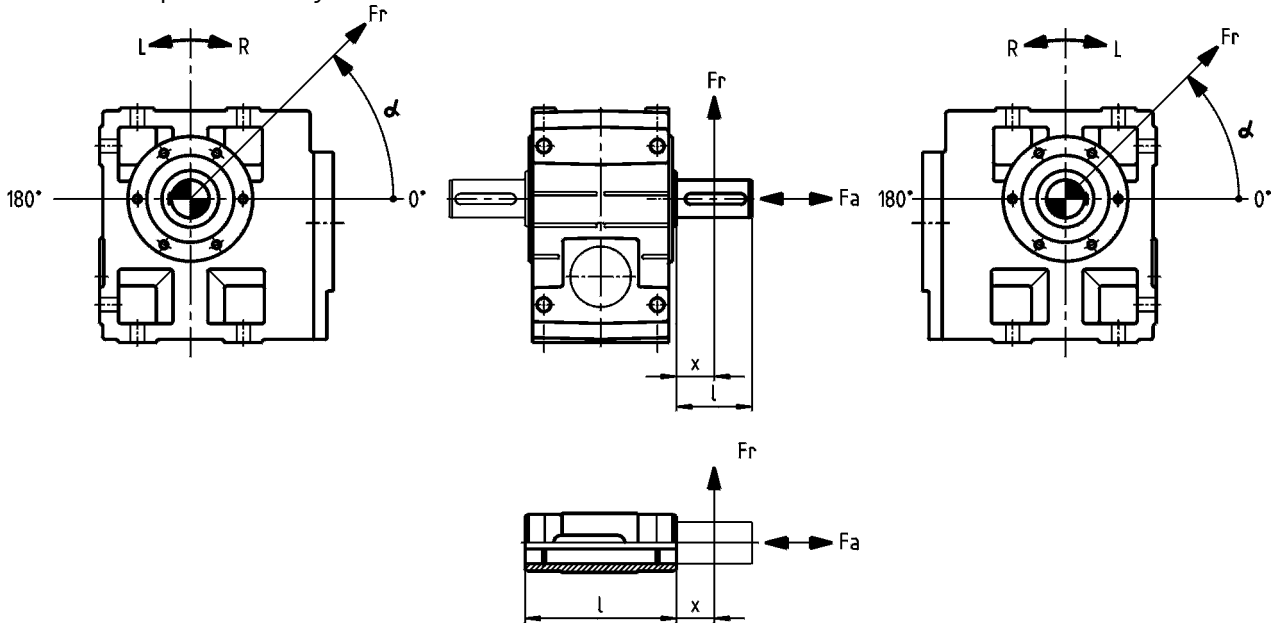

Effective direction factor f_{α} at output shaft

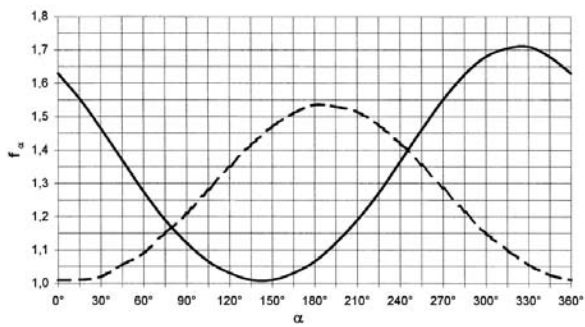

- Direction of rotation R
- - - Direction of rotation L

Additional load factor f_w at output shaft

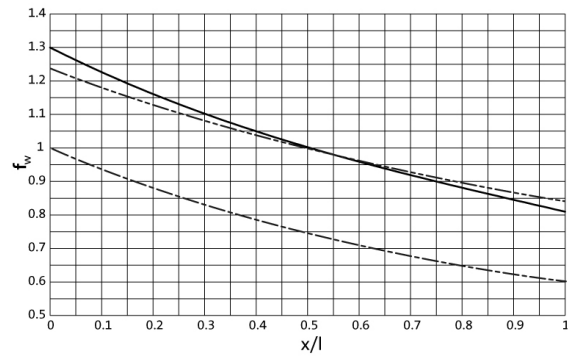

- Solid shaft (V□R)
- - - Solid shaft with flange (V□K)
- · - Hollow shaft (H□□)

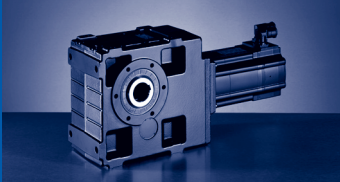

Solid shaft without flange (V□R)														
Application of force Fr: centre of shaft journal (x = l/2)														
Fa _{Tab} only valid for Fr = 0														
	GKS04-3		GKS05-3/4		GKS06-3/4		GKS07-3/4		GKS09-3/4 ¹⁾		GKS11-3/4 ¹⁾		GKS14-3/4	
n ₂ [min ⁻¹]	Fr _{Tab} [N]	Fa _{Tab} [N]	Fr _{Tab} [N]	Fa _{Tab} [N]	Fr _{Tab} [N]	Fa _{Tab} [N]	Fr _{Tab} [N]	Fa _{Tab} [N]	Fr _{Tab} [N]	Fa _{Tab} [N]	Fr _{Tab} [N]	Fa _{Tab} [N]	Fr _{Tab} [N]	Fa _{Tab} [N]
630	2400	3300	2200	2800	2700	3500	-	-	-	-	-	-	-	-
400	3000	4200	2800	3500	3700	4440	4000	4900	6200	6500	7100	7000	57900	35000
250	3400	5000	3200	4240	4300	5580	4900	6230	6400	7400	7500	8000	61000	35000
160	3600	5500	3600	5090	4900	6930	5800	7820	7100	8000	8200	9200	64100	35000
100	3600	5500	4100	6160	5300	8710	6600	9940	8400	10500	10000	12000	65000	35000
63	3600	5500	4900	6600	6200	10000	8000	12600	9500	13000	11200	14500	65000	35000
40	3600	5500	5800	6600	7900	10000	9600	14000	11800	17000	13000	18500	65000	35000
25	3600	5500	5800	6600	9000	10000	12000	14000	16000	21000	19000	27000	65000	35000
≤ 16	3600	5500	5800	6600	9000	10000	12000	14000	18000	21000	23000	27000	65000	35000
Fr _{max}	3600	-	5800	-	9000	-	12000	-	18000	-	23000	-	65000	-

¹⁾ Reinforced output shaft bearings are available on request for V□R versions.

Solid shaft with flange (V□K)														
Application of force Fr: centre of shaft journal (x = l/2)														
Fa _{Tab} only valid for Fr = 0														
	GKS04-3		GKS05-3/4		GKS06-3/4		GKS07-3/4		GKS09-3/4		GKS11-3/4		GKS14-3/4	
n ₂ [min ⁻¹]	Fr _{Tab} [N]	Fa _{Tab} [N]	Fr _{Tab} [N]	Fa _{Tab} [N]	Fr _{Tab} [N]	Fa _{Tab} [N]	Fr _{Tab} [N]	Fa _{Tab} [N]	Fr _{Tab} [N]	Fa _{Tab} [N]	Fr _{Tab} [N]	Fa _{Tab} [N]	Fr _{Tab} [N]	Fa _{Tab} [N]
630	3100	3300	3800	2900	4700	3700	-	-	-	-	-	-	-	-
400	3800	4200	4640	3630	6400	4660	7000	5700	9900	6000	14500	7000	20500	8400
250	4300	4400	5420	4440	7500	5880	8250	7000	10500	6600	16000	7500	23700	10000
160	4600	4400	6280	5420	8800	7320	9630	8500	12000	7600	17600	8500	27200	11500
100	4600	4400	7000	6600	9800	9230	11000	10400	14000	10000	21000	10500	31300	13000
63	4600	4400	7000	6600	10000	10000	13000	11500	15000	12000	24500	13000	35000	15000
40	4600	4400	7000	6600	10000	10000	14000	11500	15000	15000	28000	17500	41000	19000
25	4600	4400	7000	6600	10000	10000	14000	11500	15000	17000	30000	27000	43000	28000
≤ 16	4600	4400	7000	6600	10000	10000	14000	11500	15000	17000	30000	27000	43000	35000
Fr _{max}	4600	-	7000	-	10000	-	14000	-	15000	-	30000	-	43000	-

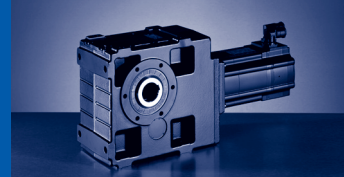

Hollow shaft (H□□)														
Application of force Fr: on hollow shaft end face (x = 0)														
Fa _{Tab} only valid for Fr = 0														
	GKS04-3		GKS05-3/4		GKS06-3/4		GKS07-3/4		GKS09-3/4		GKS11-3/4		GKS14-3/4	
n ₂ [min ⁻¹]	Fr _{Tab} [N]	Fa _{Tab} [N]	Fr _{Tab} [N]	Fa _{Tab} [N]	Fr _{Tab} [N]	Fa _{Tab} [N]	Fr _{Tab} [N]	Fa _{Tab} [N]	Fr _{Tab} [N]	Fa _{Tab} [N]	Fr _{Tab} [N]	Fa _{Tab} [N]	Fr _{Tab} [N]	Fa _{Tab} [N]
630	3100	3300	2400	2800	3000	3500	-	-	-	-	-	-	-	-
400	3900	4200	3500	3500	4600	4440	5400	4900	7500	6500	9000	7000	15000	6000
250	4500	5000	4200	4240	5600	5580	6300	6230	8200	7400	10000	8000	15500	8000
160	5100	5500	4630	5090	6400	6930	7400	7820	9400	8000	11000	9200	16500	10000
100	5900	5500	5000	6160	7000	8710	8700	9940	10600	10500	14000	12000	17500	13000
63	6800	5500	6200	6600	8200	10000	10500	12600	12200	13000	16000	14500	18500	16000
40	7000	5500	7300	6600	10400	10000	12500	14000	15500	17000	18500	18500	21000	20000
25	7000	5500	7300	6600	12000	10000	15100	14000	21000	21000	25000	27000	28000	28000
≤ 16	7000	5500	7300	6600	12000	10000	16000	14000	24000	21000	30000	27000	40000	35000
Fr _{max}	7000	-	7300	-	12000	-	16000	-	24000	-	30000	-	45000	-

- ▶ Neither radial nor axial forces are permissible for the hollow shaft with shrink disc (S□□).

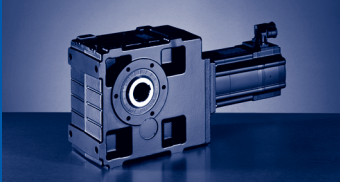

Output backlash in angular minutes

GKS04...14-3

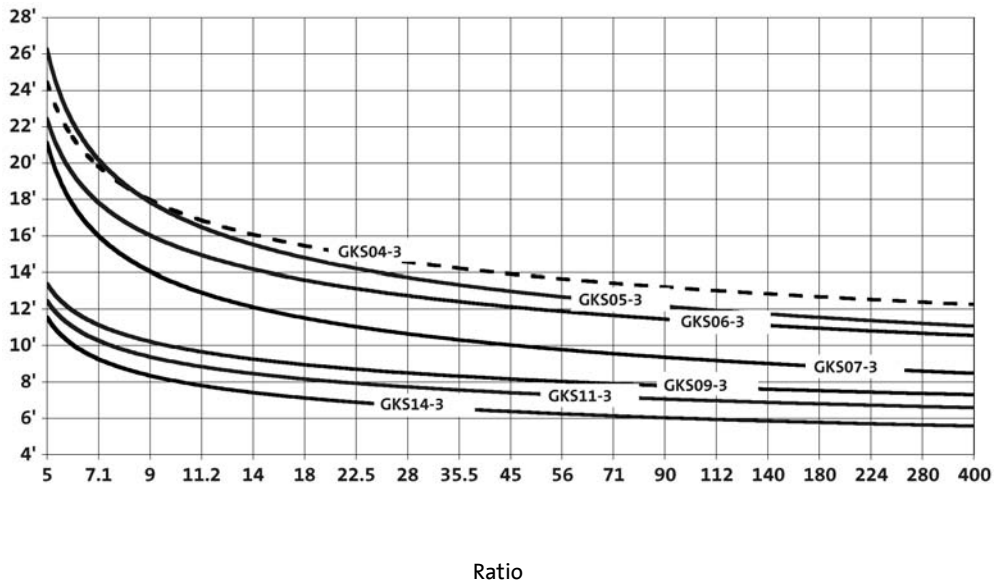

GKS05...14-4

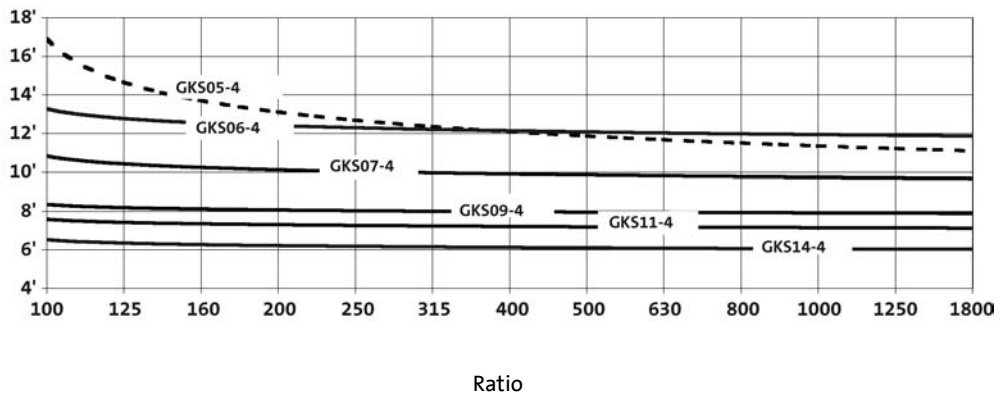

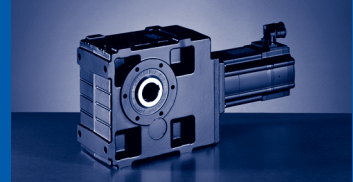

Position of ventilation, sealing elements and oil control

GKS05...14-3

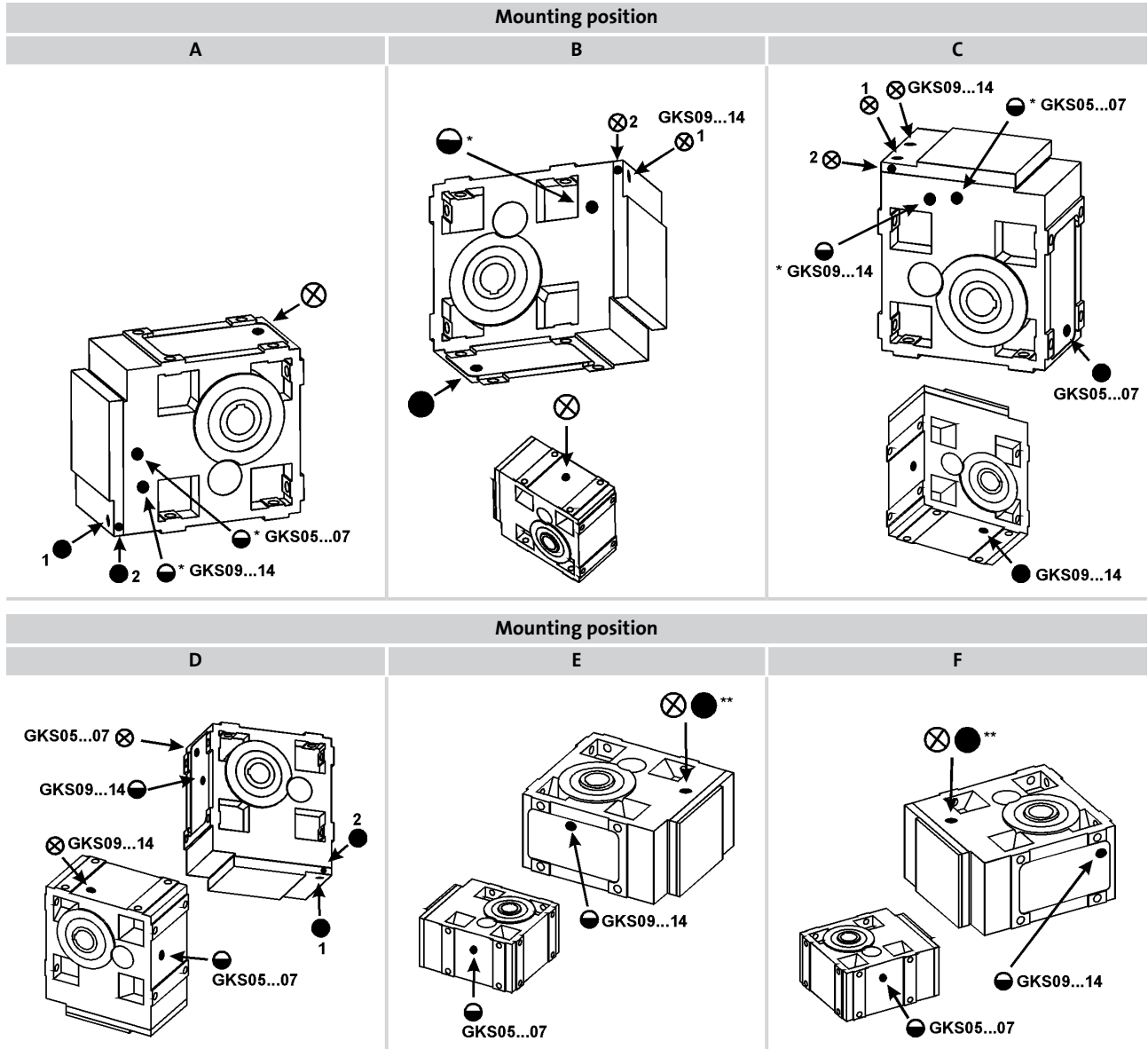

- ⊗ Ventilation/oil filler plug
- Oil drain plug
- Oil control plug
- * On both sides
- ** Opposite

Pos.1 standard
 Pos.2 only on GKS05-3A □□□ 14LC□□

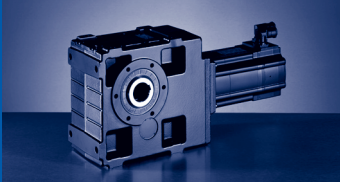

Position of ventilation, sealing elements and oil control

GKS05...14-4

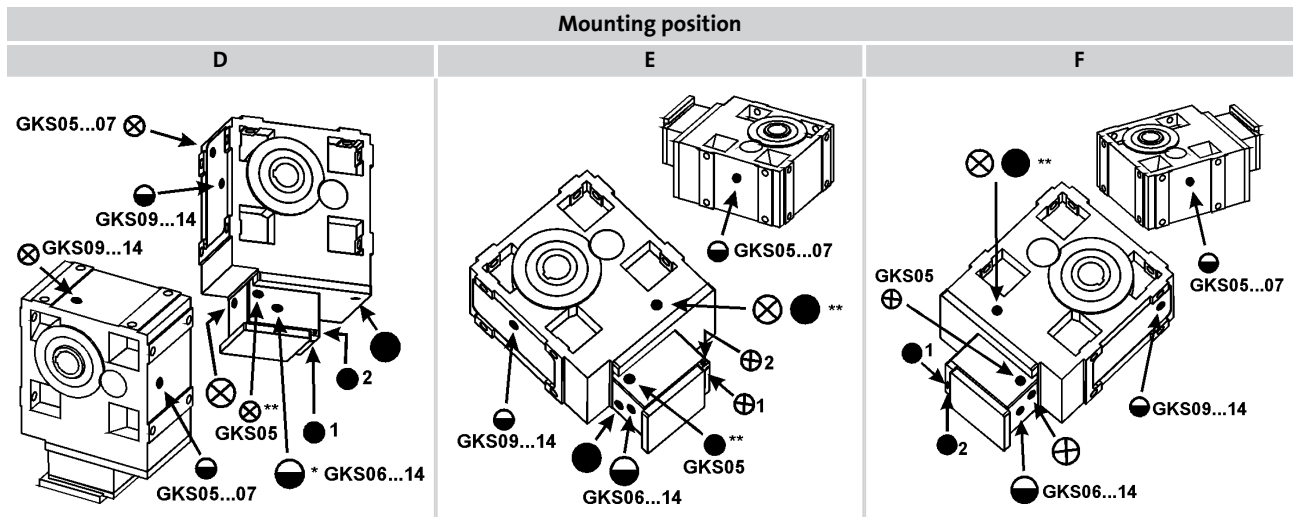
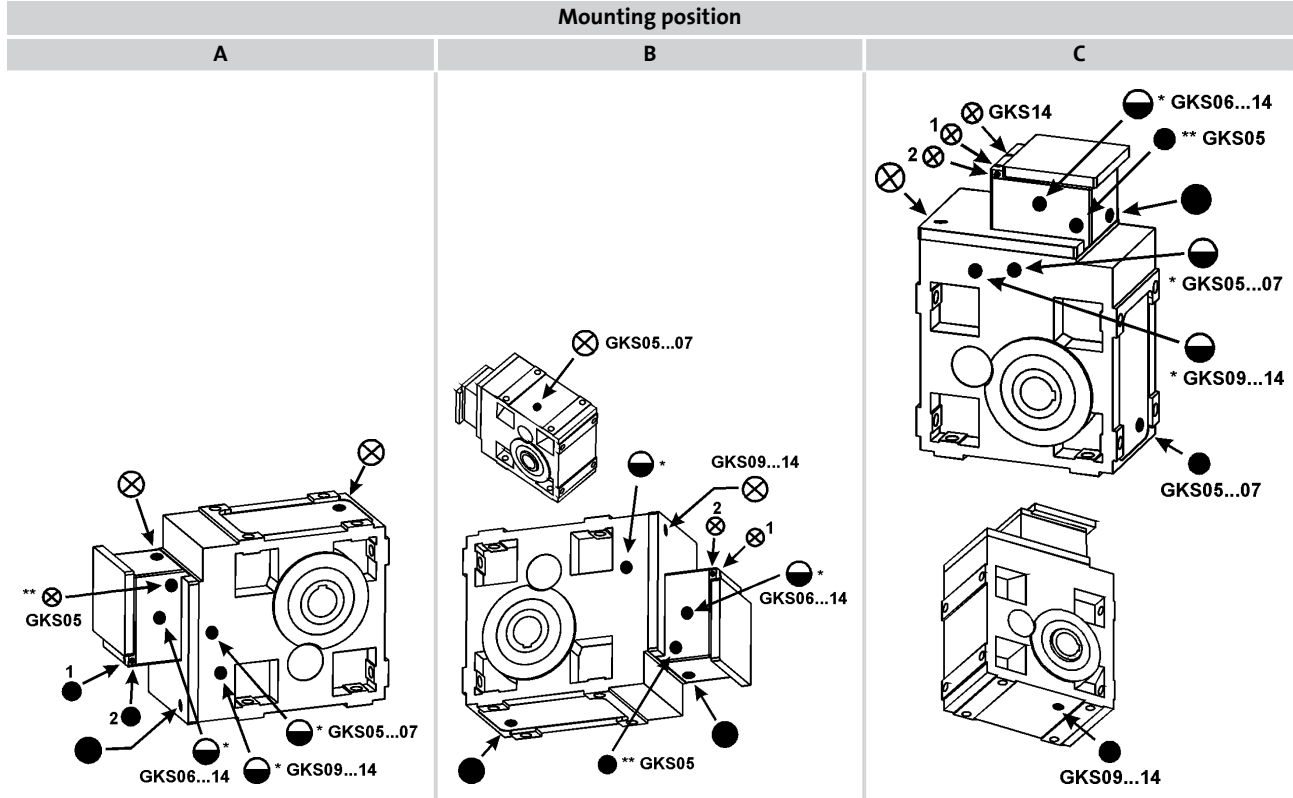

- ⊗ Ventilation/oil filler plug
- Oil drain plug
- Oil control plug
- * On both sides
- ** Opposite

Pos.1 standard
 Pos.2 only on GKS07-4A □□□ 14LC□□

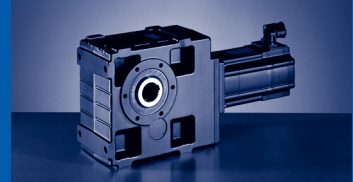

Compensation reservoir for mounting position C

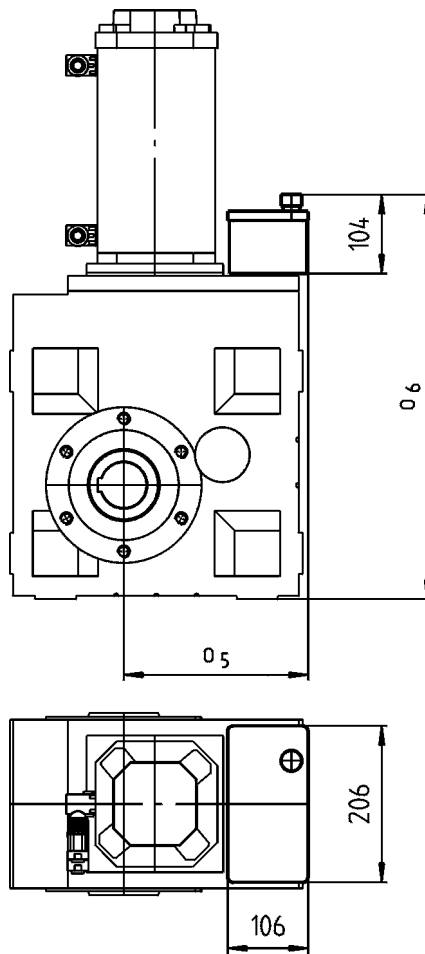

GKS□□-3A...		14LC□□ ¹⁾	17NC□□ ¹⁾	19SC□□ ¹⁾	21XC□□ ¹⁾	GKS□□-3S...		12□C□□	14□C□□	19□C□□
GKS09...	o ₅	243		265	282	GKS09...	o ₅	243		282
	o ₆	533					o ₆	533		
GKS11...	o ₅	258		280	304	GKS11...	o ₅	258		304
	o ₆	626		630			o ₆	626		630
GKS14...	o ₅			313	343	GKS14...	o ₅			343
	o ₆			739			o ₆			739

¹⁾ Connector/terminal box position 4 is not permitted.

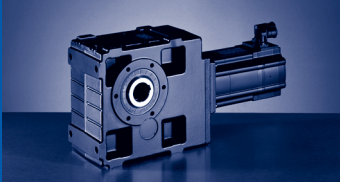

GKS [kg]

GKS□□-3S HAR/HBR...RSO B0

	06C C41	06F C41	06I C41	09D C41	09F C38	09H C41	09L C41	12D C20	12D C41	12H C15	12H C30	12H C35	12L C20	12L C41
GKS04...	14	15		17	18	19	21							
GKS05...	23		24	25	26	27	29			32		35		
GKS06...	38		39	40	41	42	44	43		46		49		
GKS07...				66	67	68	70	69		73		76		
GKS09...								119		122		125		

	14D C15	14D C36	14H C15	14H C32	14L C15	14L C32	14P C14	14P C32	19F C14	19F C30	19J C14	19J C30	19P C14	19P C30
GKS06...	48		53		58		63							
GKS07...	75		79		84		89		91		98		108	
GKS09...	124		129		133		138		140		147		157	
GKS11...	224		229		233		238		239		246		256	
GKS14...								409		416		426		

GKS□□-4S HAR/HBR...RSO B0

	06C C41	06F C41	06I C41	09D C41	09F C38	09H C41	09L C41	12D C20	12D C41	12H C15	12H C30	12H C35	12L C20	12L C41
GKS05...	25		26	28	29	30	32							
GKS06...	42		43	45	46	47	49							
GKS07...	71		72	73	74	75	77			80		83		
GKS09...	125		126	127	128	129	131	130		133		137		
GKS11...				235	236	237	239	238		242		245		
GKS14...								425		428		431		

	14D C15	14D C36	14H C15	14H C32	14L C15	14L C32	14P C14	14P C32	19F C14	19F C30	19J C14	19J C30	19P C14	19P C30
GKS09...	135		140		145		150							
GKS11...	244		249		253		258		261		268		278	
GKS14...	430		435		439		444		446		453		463	

Note additional weights.
Weights in [kg] with oil capacity for mounting position A, all given as approximate values

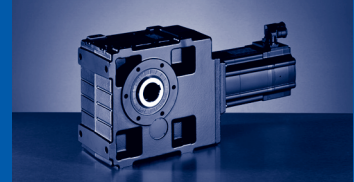

GKS□□-3A HAR/HBR...RSO B0

	10I C40 ...S00	13I C41 ...S00	13I C34 ...F10	14L C20 ...S00	14L C41 ...S00	14L C16 ...F10	14L C35 ...F10	17N C23 ...S00	17N C41 ...S00
GKS04...	18	23	24						
GKS05...	28	32	34		38		40		
GKS06...	42	46	48		52		54		60
GKS07...	68	72	74		78		80		86
GKS09...					126		128		134
GKS11...					226		228		234
GKS14...									

	17N C17 ...F10	17N C35 ...F10	19S C23 ...S00	19S C42 ...S00	19S C17 ...F10	19S C35 ...F10	21X C25 ...S00	21X C42 ...S00	21X C17 ...F10	21X C35 ...F10
GKS05...										
GKS06...		63								
GKS07...		88		109		112		126		129
GKS09...		137		157		160		175		178
GKS11...		236		256		259		273		276
GKS14...				427		430		441		445

GKS□□-4A HAR/HBR...RSO B0

	10I C40 ...S00	13I C41 ...S00	13I C34 ...F10	14L C20 ...S00	14L C41 ...S00	14L C16 ...F10	14L C35 ...F10	17N C23 ...S00	17N C41 ...S00
GKS05...	29	33	35						
GKS06...	46	50	52						
GKS07...	76	80	82		86		88		
GKS09...	129	133	135		139		141		147
GKS11...	237	241	243		247		249		255
GKS14...					432		434		440

	17N C17 ...F10	17N C35 ...F10	19S C23 ...S00	19S C42 ...S00	19S C17 ...F10	19S C35 ...F10	21X C25 ...S00	21X C42 ...S00	21X C17 ...F10	21X C35 ...F10
GKS09...		150								
GKS11...		257		278		282		295		299
GKS14...		443		463		466		481		484

Note additional weights.

Weights in [kg] with oil capacity for mounting position A, all given as approximate values

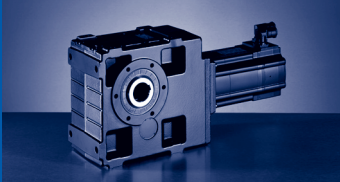

GKS [kg]

Additional weights MCS servo motors

	06C C41	06F C41	06I C41	09D C41	09F C38	09H C41	09L C41	12D C20	12D C41	12H C15	12H C30	12H C35	12L C20	12L C41
...P1	0.3			0.8				0.9						
...P2				0.5				1.2						
...SCS/SCM/SRM/SRS ...ECN/EQN	0.4			0.2				0.3						

	14D C15	14D C36	14H C15	14H C32	14L C15	14L C32	14P C14	14P C32	19F C14	19F C30	19J C14	19J C30	19P C14	19P C30	
...P1	1.9							1.5							
...P2	3.1										4.3				
...SCS/SCM/SRM/SRS ...ECN/EQN								0.3							

Additional weights MCA servo motors

	10I C40 ...S00	13I C41 ...S00	13I C34 ...F10	14L C20 ...S00	14L C41 ...S00	14L C16 ...F10	14L C35 ...F10	17N C23 ...S00	17N C41 ...S00
...P1/P5								2.4	
...P2/P6	0.8	1.4		1.5					
...CDD ...ECN/EQN/EQI ...SCS/SCM/SRM/SRS/S20 ...T20	0.3	0.5		0.6				0.7	

	17N C17 ...F10	17N C35 ...F10	19S C23 ...S00	19S C42 ...S00	19S C17 ...F10	19S C35 ...F10	21X C25 ...S00	21X C42 ...S00	21X C17 ...F10	21X C35 ...F10
...P1/P5	2.4		4.8				5			
...P2/P6										
...CDD ...ECN/EQN/EQI ...SCS/SCM/SRM/SRS/S20 ...T20	0.7		1				1.1			

Additional weights gearbox

	Solid shaft	2nd output shaft end	Hollow shaft with shrink disc	Flange	Casing foot torque plate	Threaded hole circle torque plate
	V□□	V□□	S□□	□□K		
GKS04...	0.6	0.2	0.6	2.5	1.3	0.9
GKS05...	1	0.3	0.8	4	2.2	1.3
GKS06...	2.5	0.8	1	7	3.7	2.1
GKS07...	5	1.5	1.5	11	6.6	3.7
GKS09...	8	2.7	3	16	13	
GKS11...	16	6.3	5	24	23	
GKS14...	33	12	11	33	44	

Weights in [kg]

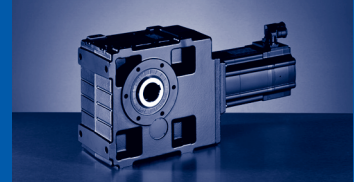

$$\triangleright i_g = z_g / z_t$$

	i	z_g	z_t
GKS04-3	5.123	67620	13200
	7.025	77280	11000
	8.167	73500	9000
	8.991	83076	9240
	9.836	108192	11000
	11.73	77420	6600
	13.067	78400	6000
	14.333	90300	6300
	16.087	88480	5500
	17.92	89600	5000
	20.588	95116	4620
	22.522	123872	5500
	25.088	125440	5000
	28.727	132720	4620
	32	134400	4200
	35.191	139356	3960
	39.2	141120	3600
	44.24	145992	3300
	50.943	168112	2640
	56.976	150416	2772
	64.978	180120	2420
	72.21	174748	2376
	79.598	189126	1980
	90.491	179172	1800
	100.067	198132	1584
	111.467	200640	1440
	128.874	204136	1452
	143.556	206720	1320
	163.332	237158	1188
	181.939	240160	1080
204.682	243162	924	
228	246240	840	
269.66	249166	840	
300.381	252320	840	
GKS05-3	6.863	73500	10710
	9.412	84000	8925
	10.569	80850	7650
	11.667	83300	7140
	13.176	117600	8925
	14.494	92400	6375
	16	95200	5950
	17.054	86975	5100
	19.216	88200	4590
	23.388	99400	4250
	26.353	100800	3825

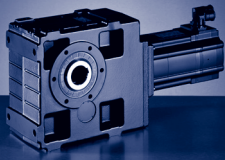

► $i_g = z_g / z_t$

	i	z_g	z_t
GKS05-3	29.931	106855	3570
	32.744	139160	4250
	36.894	141120	3825
	41.765	149100	3570
	47.059	151200	3213
	51.162	156555	3060
	57.647	158760	2754
	66.592	203770	3060
	75.033	206640	2754
	82.833	168980	2040
	93.333	171360	1836
	107.196	218680	2040
	120.784	221760	1836
	130.097	221165	1700
	146.588	224280	1530
	166.276	226135	1360
	187.353	229320	1224
	211.2	228096	1080
	227.484	227484	1000
	256.32	230688	900
290.745	232596	800	
327.6	235872	720	
GKS05-4	95.238	8568000	89964
	114.987	8796480	76500
	126.933	9063040	71400
	146.667	9424800	64260
	161.905	9710400	59976
	185.547	9462880	51000
	209.067	9596160	
	225.867	10367280	45900
	236.667	10138800	42840
	289.917	10645740	36720
	326.667	10795680	33048
	364.467	11152680	30600
	410.667	11309760	27540
	469.389	11490640	24480
	510	13109040	25704
	528.889	11652480	22032
	594.894	13349420	22440
	670.303	13537440	20196
	820.76	11818944	14400
	924.8	11985408	12960
1040.215	13730832	13200	
1172.073	13924224	11880	
1303.56	14078448	10800	

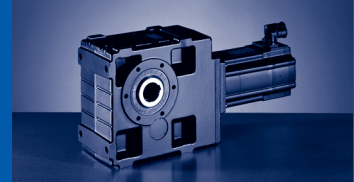

$$\triangleright i_g = z_g / z_t$$

	i	z_g	z_t
GKS05-4	1468.8	14276736	9720
	1717.389	14426064	8400
	1935.086	14629248	7560
GKS06-3	6.485	66150	10200
	9.196	70350	7650
	10.147	72450	7140
	11.382	81270	
	12.612	80400	6375
	14.824	75600	5100
	16.699	76650	4590
	17.809	89010	4998
	20.329	86400	4250
	22.902	87600	3825
	26.017	92880	3570
	28.461	120960	4250
	32.063	122640	3825
	36.303	129600	3570
	41.472	103680	2500
	44.471	136080	3060
	53.074	111456	2100
	57.882	177120	3060
	65.207	179580	2754
	72	146880	2040
	81.111	148920	1836
	93.176	190080	2040
	104.967	192720	1836
	113.082	192240	1700
	127.392	194910	1530
	142.941	194400	1360
	161.029	197100	1224
	190.08	228096	1200
214.133	231264	1080	
230.688	230688	1000	
259.88	233892	900	
291.6	233280	800	
328.5	236520	720	
GKS06-4	103.721	7776000	74970
	113.205	10184400	89964
	127.059	8164800	64260
	140.816	8445600	59976
	155.647	8573040	55080
	174.336	11202840	64260
	202.588	11158560	55080
	224.524	11542320	51408
252	9253440	36720	

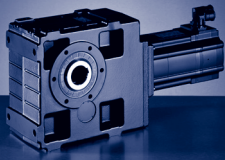

► $i_g = z_g / z_t$

	i	z_g	z_t
GKS06-4	279.286	9571680	34272
	316.8	9694080	30600
	361.429	12386880	34272
	408	9987840	24480
	458.067	14390640	31416
	517.091	11603520	22440
	555.927	14554170	26180
	640.8	13072320	20400
	696.668	14922630	21420
	812.137	15186960	18700
	914.907	15397890	16830
	1017.741	15571440	15300
	1146.529	15787710	13770
	1340.834	15955920	11900
	1510.507	16177530	10710
GKS07-3	5.955	65280	10962
	8.254	74880	9072
	9.171	71808	7830
	10.124	73984	7308
	11.378	107520	9450
	12.711	82368	6480
	14.798	77248	5220
	16.674	78336	4698
	17.27	91392	5292
	20.511	88608	4320
	23.111	89856	3888
	25.244	95424	3780
	28.274	127232	4500
	31.858	129024	4050
	36.063	136320	3780
	40.906	107991	2640
	44.178	143136	3240
	50.345	116298	2310
	57.501	186304	3240
	64.79	188928	2916
	70.474	152224	2160
	79.407	154368	1944
	92.563	199936	2160
	104.296	202752	1944
	112.338	202208	1800
	126.578	205056	1620
140.548	185523	1320	
158.364	188136	1188	
184.6	243672	1320	
208	247104	1188	

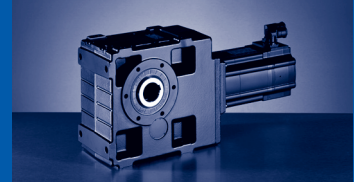

$$\triangleright i_g = z_g / z_t$$

	i	z_g	z_t
GKS07-3	224.037	246441	1100
	252.436	249912	990
	283.193	249210	880
	319.091	252720	792
GKS07-4	103.039	8179200	79380
	112.391	10705920	95256
	126.222	8588160	68040
	137.748	8747520	63504
	154.622	9017568	58320
	179.201	14631424	81648
	201.254	11737152	58320
	222.909	12133376	54432
	246.659	9590112	38880
	273.199	9913856	36288
	321.049	12482368	38880
	358.829	13021184	36288
	399.353	10351232	25920
	464.367	16850944	36288
	516.81	13395712	25920
	563.572	17042432	30240
	636.581	13750144	21600
	683.972	17236096	25200
	823.81	17794304	21600
	928.237	18044928	19440
999.806	17996512	18000	
1126.542	18249984	16200	
1277.842	18400928	14400	
1439.822	18660096	12960	
GKS09-3	12.283	87516	7125
	13.36	88842	6650
	16.122	96492	5985
	17.536	97954	5586
	19.541	92820	4750
	22.022	94146	4275
	25.649	102340	3990
	29.228	133280	4560
	32.94	135184	4104
	35.193	140420	3990
	39.662	142426	3591
	43.146	147560	3420
	48.625	149668	3078
	58.456	199920	3420
	65.879	202776	3078
	70.982	161840	2280
79.996	164152	2052	

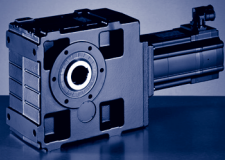

► $i_g = z_g / z_t$

	i	z_g	z_t
GKS09-3	91.86	209440	2280
	103.524	212432	2052
	111.484	211820	1900
	125.641	214846	1710
	140.921	214200	1520
	158.816	217260	1368
	182	240240	1320
	205.111	243672	1188
	220.882	242970	1100
	248.93	246441	990
	279.205	245700	880
	314.659	249210	792
	GKS09-4	100.551	8425200
113.32		8545560	75411
123.275		8853600	71820
138.929		8980080	64638
151.012		9296280	61560
170.188		9429084	55404
204.596		12594960	61560
230.577		12774888	55404
248.439		10195920	41040
279.986		10341576	36936
323.365		13270880	41040
364.427		13460464	36936
402.234		11005120	27360
453.311		11162336	24624
520.538		14241920	27360
586.638		14445376	24624
631.744		14403760	22800
711.965		14609528	20520
817.551		18640160	22800
921.367		18906448	20520
992.209		18851980	19000
1118.204	19121294	17100	
1254.197	19063800	15200	
1413.461	19336140	13680	
GKS11-3	12.094	95238	7875
	13.154	96681	7350
	15.874	105006	6615
	17.265	106597	6174
	19.515	102453	5250
	21.989	103896	4725
	25.615	112961	4410
	28.021	147112	5250
	31.573	149184	4725

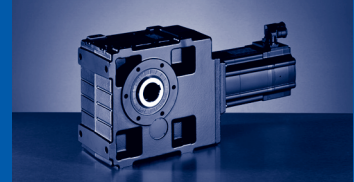

► $i_g = z_g / z_t$

	i	z_g	z_t
GKS11-3	35.741	157620	4410
	40.272	159840	3969
	43.783	165501	3780
	49.333	167832	3402
	57.683	218041	3780
	64.995	221112	3402
	70.887	178636	2520
	79.873	181152	2268
	91.737	231176	2520
	103.365	234432	2268
	111.335	233803	2100
	125.448	237096	1890
	140.732	236430	1680
	158.571	239760	1512
	186.572	268664	1440
	210.222	272448	1296
	226.431	271717	1200
	255.133	275544	1080
	286.219	274770	960
	322.5	278640	864
GKS11-4	102.119	9457200	92610
	115.063	9590400	83349
	125.095	9930060	79380
	140.952	10069920	71442
	153.242	10426563	68040
	172.667	10573416	61236
	201.89	13736583	68040
	227.481	13930056	61236
	248.106	11254068	45360
	279.556	11412576	40824
	322.931	14648152	45360
	363.866	14854464	40824
	395.787	11968612	30240
	445.958	12137184	27216
	512.196	15488792	30240
	577.122	15706944	27216
	621.619	15664801	25200
	700.416	15885432	22680
	816.455	20574664	25200
	919.949	20864448	22680
990.879	20808467	21000	
1116.484	21101544	18900	
1252.516	21042270	16800	
1411.286	21338640	15120	

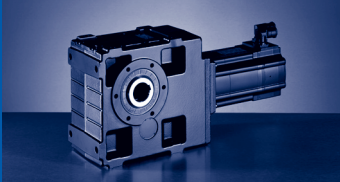

► $i_g = z_g / z_t$

	i	z_g	z_t
GKS14-3	12.435	102960	8280
	13.525	104520	7728
	16.646	112560	6762
	18.311	147400	8050
	20.065	110760	5520
	22.609	112320	4968
	24.696	119280	4830
	27.165	156200	5750
	30.609	158400	5175
	34.692	167560	4830
	39.089	169920	4347
	42.531	176080	4140
	47.923	178560	3726
	56.251	232880	4140
	63.382	236160	3726
	68.942	190280	2760
	77.681	192960	2484
	90.551	249920	2760
	102.029	253440	2484
	109.896	252760	2300
	123.826	256320	2070
	138.913	255600	1840
	156.522	259200	1656
	186.572	268664	1440
	210.222	272448	1296
	226.431	271717	1200
255.133	275544	1080	
286.219	274770	960	
322.5	278640	864	
GKS14-4	97.467	9886040	101430
	109.822	10025280	91287
	119.493	10388720	86940
	134.64	10535040	78246
	158.039	13739920	86940
	178.072	13933440	78246
	193.754	14438560	74520
	218.315	14641920	67068
	237.467	11797360	49680
	267.568	11963520	44712
	321.729	15983520	49680
	362.512	16208640	44712
	390.671	12939040	33120
	440.193	13121280	29808
	513.121	16994560	33120
	578.164	17233920	29808

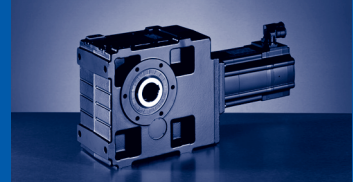

▶ $i_g = z_g / z_t$

	i	z_g	z_t
GKS14-4	622.742	17187680	27600
	701.681	17429760	24840
	805.901	22242880	27600
	908.058	22556160	24840
	978.071	22495640	23000
	1102.052	22812480	20700
	1236.326	22748400	18400
	1393.043	23068800	16560

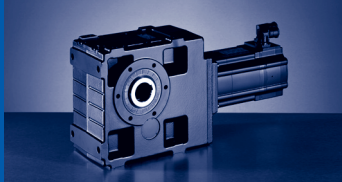

GKS [Nm]

GKS□□-□S (MCS)

$M_{2GN} \leq 187 \text{ Nm}$

GKS04-3S				06CC41	06FC41	06IC41	09DC41	09FC38	09HC41	09LC41
				...500	...500	...500	...500	...500	...500	...500
i	M_{2GN}	J_G	M_1	0.6	1.2	1.5	2.3	3.1	3.8	4.5
			n_1	4050	4050	4050	4050	3750	4050	4050
			I_{M230}	2.6	2.9	3.2	4.6	5	6.8	8.4
			I_{M400}	1.3	1.5	1.6	2.3	2.5	3.4	4.2
			P_N	0.25	0.51	0.64	1	1.2	1.6	1.9
			J_M	0.17	0.25	0.33	1.13	1.53	1.93	2.83
5.123	81	1.17	M_2				11	15	18	22
			c				5.2	3.9	3.1	2.6
			$n_{2 \text{ Eck}}$				791	732	791	791
			$n_{2 \text{ th}}$				708	674	646	625
7.025	93	0.68	M_2				15	20	25	30
			c				4.3	3.3	2.6	2.2
			$n_{2 \text{ Eck}}$				577	534	577	577
			$n_{2 \text{ th}}$				554	529	508	493
8.167	128	0.86	M_2				17	23	29	34
			c				5.2	3.9	3.1	2.6
			$n_{2 \text{ Eck}}$				496	459	496	496
			$n_{2 \text{ th}}$				444	423	405	392
8.991	103	0.44	M_2			12	19	26	32	38
			c			5.8	3.8	2.9	2.3	1.9
			$n_{2 \text{ Eck}}$			451	451	417	451	451
			$n_{2 \text{ th}}$			450	450	417	450	440
9.836	106	0.38	M_2			13	21	28	35	42
			c			5.5	3.6	2.7	2.2	1.8
			$n_{2 \text{ Eck}}$			412	412	381	412	412
			$n_{2 \text{ th}}$			412	412	381	412	406
11.73	180	0.73	M_2				25	34	41	49
			c				5	3.8	3.1	2.6
			$n_{2 \text{ Eck}}$				345	320	345	345
			$n_{2 \text{ th}}$				308	293	281	271
13.067	165	0.7	M_2				28	38	46	55
			c				4.2	3.2	2.5	2.1
			$n_{2 \text{ Eck}}$				310	287	310	310
			$n_{2 \text{ th}}$				267	254	242	234
14.333	164	0.35	M_2			19	30	41	51	61
			c			5.8	3.8	2.9	2.3	1.9
			$n_{2 \text{ Eck}}$			283	283	262	283	283
			$n_{2 \text{ th}}$			283	283	262	283	276
16.087	181	0.44	M_2			22	34	46	57	68
			c			5.7	3.7	2.8	2.2	1.9
			$n_{2 \text{ Eck}}$			252	252	233	252	252
			$n_{2 \text{ th}}$			252	236	225	216	206
17.92	166	0.43	M_2		19	25	38	52	64	76
			c		5.8	4.7	3.1	2.3	1.8	1.6
			$n_{2 \text{ Eck}}$		226	226	226	209	226	226
			$n_{2 \text{ th}}$		226	220	205	195	183	169
20.588	182	0.3	M_2		22	28	44	60	74	88
			c		5.6	4.5	2.9	2.2	1.8	1.5
			$n_{2 \text{ Eck}}$		197	197	197	182	197	197
			$n_{2 \text{ th}}$		197	197	197	182	183	168
22.522	182	0.26	M_2		25	31	48	66	81	96
			c		5.1	4.1	2.7	2	1.6	1.4
			$n_{2 \text{ Eck}}$		180	180	180	167	180	180
			$n_{2 \text{ th}}$		180	180	180	167	167	154
25.088	167	0.25	M_2		28	35	54	73	90	107
			c		4.2	3.4	2.2	1.7	1.3	1.1
			$n_{2 \text{ Eck}}$		161	161	161	150	161	161
			$n_{2 \text{ th}}$		161	161	161	149	137	128

$M \dots [\text{Nm}]$
 $n \dots [\text{min}^{-1}]$
 $J \dots [\text{kgcm}^2]$

$P \dots [\text{kW}]$
 $I \dots [\text{A}]$
 $i \dots [-]$
 $c \dots [-]$

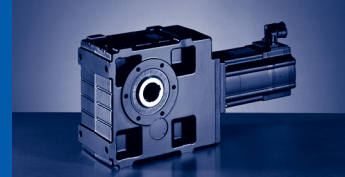

$M_{2GN} \leq 187 \text{ Nm}$

GKS04-3S				06CC41	06FC41	06IC41	09DC41	09FC38	09HC41	09LC41
				...500	...500	...500	...500	...500	...500	...500
i	M_{2GN}	J_G	M_1	0.6	1.2	1.5	2.3	3.1	3.8	4.5
			n_1	4050	4050	4050	4050	3750	4050	4050
			I_{M230}	2.6	2.9	3.2	4.6	5	6.8	8.4
			I_{M400}	1.3	1.5	1.6	2.3	2.5	3.4	4.2
			P_N	0.25	0.51	0.64	1	1.2	1.6	1.9
			J_M	0.17	0.25	0.33	1.13	1.53	1.93	2.83
28.727	183	0.18	M_2		32	40	62	84	103	123
			c		4	3.2	2.1	1.6	1.3	
			$n_{2 \text{ Eck}}$		141	141	141	131	141	141
			$n_{2 \text{ th}}$		141	141	141	131	135	127
32	167	0.18	M_2		36	45	69	94	115	
			c		3.3	2.6	1.7	1.3	1	
			$n_{2 \text{ Eck}}$		127	127	127	117	127	
			$n_{2 \text{ th}}$		127	127	127	117	113	
35.191	183	0.14	M_2		39	49	76	103	127	
			c		3.3	2.6	1.7	1.3	1	
			$n_{2 \text{ Eck}}$		115	115	115	107	115	
			$n_{2 \text{ th}}$		115	115	115	107	115	
39.2	168	0.13	M_2	21	44	55	85	115		
			c	5.4	2.7	2.2	1.4	1.1		
			$n_{2 \text{ Eck}}$	103	103	103	103	96		
			$n_{2 \text{ th}}$	103	103	103	103	96		
44.24	185	0.09	M_2	24	49	62				
			c	6	3	2.4				
			$n_{2 \text{ Eck}}$	92	92	92				
			$n_{2 \text{ th}}$	92	92	92				
50.943	182	0.18	M_2	28	57	72	111	150		
			c	5.1	2.6	2.1	1.3	1		
			$n_{2 \text{ Eck}}$	80	80	80	80	74		
			$n_{2 \text{ th}}$	80	80	80	68	61		
56.976	187	0.06	M_2	31	64	80				
			c	4.7	2.4	1.9				
			$n_{2 \text{ Eck}}$	71	71	71				
			$n_{2 \text{ th}}$	71	71	71				
64.978	183	0.13	M_2	36	73	92	142			
			c	4	2	1.6	1.1			
			$n_{2 \text{ Eck}}$	62	62	62	62			
			$n_{2 \text{ th}}$	62	62	62	56			
79.598	183	0.1	M_2	44	90	113				
			c	3.3	1.7	1.3				
			$n_{2 \text{ Eck}}$	51	51	51				
			$n_{2 \text{ th}}$	51	51	51				
100.067	185	0.07	M_2	56	114	142				
			c	2.7	1.3	1.1				
			$n_{2 \text{ Eck}}$	41	41	41				
			$n_{2 \text{ th}}$	40	40	40				
111.467	170	0.07	M_2	63	127					
			c	2.4	1.2					
			$n_{2 \text{ Eck}}$	36	36					
			$n_{2 \text{ th}}$	36	36					
128.874	187	0.05	M_2	72	147					
			c	2.3	1.2					
			$n_{2 \text{ Eck}}$	31	31					
			$n_{2 \text{ th}}$	31	31					
143.556	172	0.05	M_2	81						
			c	1.9						
			$n_{2 \text{ Eck}}$	28						
			$n_{2 \text{ th}}$	28						

$M \dots$ [Nm]
 $n \dots$ [min^{-1}]
 $J \dots$ [kgcm^2]

$P \dots$ [kW]
 $I \dots$ [A]
 i [-]
 c [-]

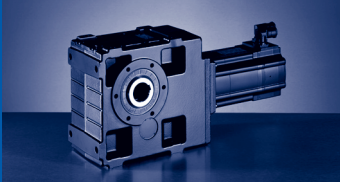

GKS [Nm]

GKS□□-□S (MCS)

$M_{2GN} \leq 331 \text{ Nm}$

GKS05-3S				06CC41	06FC41	06IC41	09DC41	09FC38	09HC41	09LC41
				...S00	...S00	...S00	...S00	...S00	...S00	...S00
i	M_{2GN}	J_G	M_1	0.6	1.2	1.5	2.3	3.1	3.8	4.5
			n_1	4050	4050	4050	4050	3750	4050	4050
			I_{M230}	2.6	2.9	3.2	4.6	5	6.8	8.4
			I_{M400}	1.3	1.5	1.6	2.3	2.5	3.4	4.2
			P_N	0.25	0.51	0.64	1	1.2	1.6	1.9
			J_M	0.17	0.25	0.33	1.13	1.53	1.93	2.83
6.863	147	1.9	M_2					19	24	29
			c					5.4	4.3	3.6
			n_2 Eck					546	590	590
			n_2 th					446	427	413
9.412	165	1.17	M_2				20	27	33	39
			c				5.8	4.4	3.5	2.9
			n_2 Eck				430	398	430	430
			n_2 th				385	366	351	339
10.569	227	1.6	M_2					30	37	44
			c					5.4	4.3	3.6
			n_2 Eck					355	383	383
			n_2 th					289	277	268
11.667	251	1.65	M_2					33	41	48
			c					5.4	4.3	3.6
			n_2 Eck					321	347	347
			n_2 th					262	251	243
13.176	165	0.71	M_2				28	38	47	56
			c				4.1	3.1	2.5	2.1
			n_2 Eck				307	285	307	307
			n_2 th				292	279	268	260
14.494	254	1.05	M_2				30	41	51	61
			c				5.8	4.4	3.5	2.9
			n_2 Eck				279	259	279	279
			n_2 th				250	238	228	220
16	280	1.04	M_2				33	45	56	67
			c				5.8	4.4	3.5	2.9
			n_2 Eck				253	234	253	253
			n_2 th				226	215	206	200
17.054	314	1.51	M_2					48	60	71
			c					4.6	3.7	3.1
			n_2 Eck					220	238	238
			n_2 th					174	166	161
19.216	297	1.47	M_2				40	55	68	81
			c				5.1	3.9	3.1	2.6
			n_2 Eck				211	195	211	211
			n_2 th				157	149	143	138
23.388	329	0.96	M_2				49	67	83	99
			c				4.6	3.5	2.8	2.4
			n_2 Eck				173	160	173	173
			n_2 th				149	141	135	131
26.353	298	0.95	M_2				56	76	94	112
			c				3.7	2.8	2.3	1.9
			n_2 Eck				154	142	154	154
			n_2 th				127	120	115	109
29.931	330	0.67	M_2			41	64	87	107	127
			c			5.6	3.6	2.8	2.2	1.9
			n_2 Eck			135	135	125	135	135
			n_2 th			131	122	116	111	105
32.744	331	0.58	M_2			45	70	95	117	139
			c			5.1	3.3	2.5	2	1.7
			n_2 Eck			124	124	115	124	124
			n_2 th			122	113	108	104	96

$M \dots$ [Nm]
 $n \dots$ [min^{-1}]
 $J \dots$ [kgcm^2]

$P \dots$ [kW]
 $I \dots$ [A]
 $i \dots$ [-]
 $c \dots$ [-]

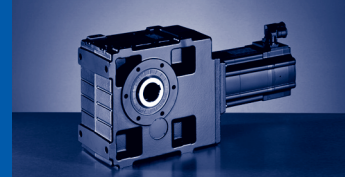

$M_{2GN} \leq 331 \text{ Nm}$

12DC20	12DC41	12HC15	12HC30	12HC35	12LC20	12LC41	GKS05-3S			
...500	...500	...500	...500	...500	...500	...500				
5.5	4.3	10	8	7.5	13.5	11	M_1	J_G	M_{2GN}	i
1950	4050	1500	3000	3525	1950	4050	n_1			
5.2	8.8	7.6	10.5		11.8		I_{M230}			
2.6	4.5	3.8		5.7	5.9	10.2	I_{M400}			
1.1	1.8	1.6	2.5	2.8	2.8	4.7	P_N			
4.12	4.12	7.42	7.42	7.42	10.72	10.72	J_M			
35	27	64	51	48	88	71	M_2			
3.8	3.8	2.3	2.2	2.3	1.5	1.5	c	1.9	147	6.863
284	590	219	437	514	284	590	$n_{2\text{Eck}}$			
284	416	219	373	374	284	309	$n_{2\text{th}}$			
48	38	89	71	66	120	98	M_2			
3.1	3.1	1.8	1.8	1.9	1.3	1.2	c	1.17	165	9.412
207	430	159	319	375	207	430	$n_{2\text{Eck}}$			
207	342	159	299	301	207	240	$n_{2\text{th}}$			
54	42	99	79	74	135	110	M_2			
3.8	3.8	2.3	2.2	2.3	1.5	1.5	c	1.6	227	10.569
185	383	142	284	334	185	383	$n_{2\text{Eck}}$			
185	270	142	242	243	185	201	$n_{2\text{th}}$			
59	46	109	87	82	149	121	M_2			
3.8	3.8	2.3	2.2	2.3	1.5	1.5	c	1.65	251	11.667
167	347	129	257	302	167	347	$n_{2\text{Eck}}$			
167	245	129	219	220	167	182	$n_{2\text{th}}$			
68	53	125	100	94			M_2			
2.2	2.2	1.3	1.3	1.3			c	0.71	165	13.176
148	307	114	228	268			$n_{2\text{Eck}}$			
148	262	114	212	213			$n_{2\text{th}}$			
74	58	136	109	102	185	151	M_2			
3.1	3.1	1.8	1.8	1.9	1.3	1.2	c	1.05	254	14.494
135	279	104	207	243	135	279	$n_{2\text{Eck}}$			
135	222	103	194	195	135	156	$n_{2\text{th}}$			
82	64	151	121	113	205	167	M_2			
3.1	3.1	1.8	1.8	1.9	1.3	1.2	c	1.04	280	16
122	253	94	188	220	122	253	$n_{2\text{Eck}}$			
122	201	94	176	177	122	141	$n_{2\text{th}}$			
87	68	160	128	120	218	178	M_2			
3.2	3.2	1.9	1.9	1.9	1.3	1.3	c	1.51	314	17.054
114	238	88	176	207	114	238	$n_{2\text{Eck}}$			
114	162	88	144	145	114	115	$n_{2\text{th}}$			
99	77	181	145	136	246	201	M_2			
2.7	2.7	1.6	1.6	1.6	1.1	1.1	c	1.47	297	19.216
102	211	78	156	183	102	211	$n_{2\text{Eck}}$			
101	139	78	116	116	96	94	$n_{2\text{th}}$			
120	94	221	177	166	300		M_2			
2.5	2.5	1.5	1.5	1.5	1		c	0.96	329	23.388
83	173	64	128	151	83		$n_{2\text{Eck}}$			
83	132	64	107	107	83		$n_{2\text{th}}$			
136	107	250	200	187			M_2			
2	2	1.2	1.2	1.2			c	0.95	298	26.353
74	154	57	114	134			$n_{2\text{Eck}}$			
74	112	57	85	85			$n_{2\text{th}}$			
155	121	284	227	213			M_2			
1.9	1.9	1.2	1.2	1.2			c	0.67	330	29.931
65	135	50	100	118			$n_{2\text{Eck}}$			
65	108	50	84	85			$n_{2\text{th}}$			
170	133	311	249	233			M_2			
1.8	1.8	1.1	1.1	1.1			c	0.58	331	32.744
60	124	46	92	108			$n_{2\text{Eck}}$			
60	98	46	79	79			$n_{2\text{th}}$			

M ... [Nm]
n ... [min⁻¹]
J ... [kgcm²]

P ... [kW]
I ... [A]
i [-]
c [-]

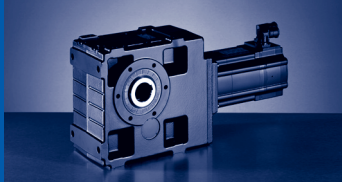

GKS [Nm]

GKS□□-□S (MCS)

$M_{2GN} \leq 331 \text{ Nm}$

GKS05-3S				06CC41	06FC41	06IC41	09DC41	09FC38	09HC41	09LC41
				...500	...500	...500	...500	...500	...500	...500
i	M_{2GN}	J_G	M_1	0.6	1.2	1.5	2.3	3.1	3.8	4.5
			n_1	4050	4050	4050	4050	3750	4050	4050
			I_{M230}	2.6	2.9	3.2	4.6	5	6.8	8.4
			I_{M400}	1.3	1.5	1.6	2.3	2.5	3.4	4.2
			P_N	0.25	0.51	0.64	1	1.2	1.6	1.9
			J_M	0.17	0.25	0.33	1.13	1.53	1.93	2.83
36.894	302	0.58	M_2		40	51	79	107	132	157
			c		5.2	4.1	2.7	2.1	1.6	1.4
			$n_{2 \text{ Eck}}$		110	110	110	102	110	110
			$n_{2 \text{ th}}$		108	104	97	92	83	77
41.765	331	0.42	M_2		46	58	90	122	150	178
			c		5	4	2.6	2	1.6	1.3
			$n_{2 \text{ Eck}}$		97	97	97	90	97	97
			$n_{2 \text{ th}}$		97	97	97	90	86	79
47.059	304	0.41	M_2		52	65	101	137	169	201
			c		4.6	3.7	2.4	1.8	1.5	1.2
			$n_{2 \text{ Eck}}$		86	86	86	80	86	86
			$n_{2 \text{ th}}$		86	86	86	80	74	68
51.162	331	0.32	M_2		56	71	110	149	184	218
			c		4.6	3.7	2.4	1.8	1.5	1.2
			$n_{2 \text{ Eck}}$		79	79	79	73	79	79
			$n_{2 \text{ th}}$		79	79	79	73	76	71
57.647	307	0.32	M_2		64	80	125	169	208	246
			c		3.8	3.1	2	1.5	1.2	1
			$n_{2 \text{ Eck}}$		70	70	70	65	70	70
			$n_{2 \text{ th}}$		70	70	70	65	62	59
66.592	331	0.2	M_2		74	93	144	195	240	
			c		3.6	2.9	1.9	1.4	1.1	
			$n_{2 \text{ Eck}}$		61	61	61	56	61	
			$n_{2 \text{ th}}$		61	61	61	56	61	
75.033	310	0.2	M_2	41	84	105	163	221		
			c	5.9	3	2.4	1.5	1.2		
			$n_{2 \text{ Eck}}$	54	54	54	54	50		
			$n_{2 \text{ th}}$	54	54	54	54	50		
82.833	331	0.14	M_2	45	93	116	180	244		
			c	5.7	2.9	2.3	1.5	1.1		
			$n_{2 \text{ Eck}}$	49	49	49	49	45		
			$n_{2 \text{ th}}$	49	49	49	49	45		
93.333	315	0.14	M_2	51	105	132	203			
			c	4.8	2.4	1.9	1.3			
			$n_{2 \text{ Eck}}$	43	43	43	43			
			$n_{2 \text{ th}}$	43	43	43	43			
107.196	331	0.09	M_2	59	121	151				
			c	4.4	2.2	1.8				
			$n_{2 \text{ Eck}}$	38	38	38				
			$n_{2 \text{ th}}$	38	38	38				
120.784	315	0.09	M_2	67	136	171				
			c	4.1	2.1	1.7				
			$n_{2 \text{ Eck}}$	34	34	34				
			$n_{2 \text{ th}}$	34	34	34				
130.097	331	0.07	M_2	72	147	184				
			c	4	2	1.6				
			$n_{2 \text{ Eck}}$	31	31	31				
			$n_{2 \text{ th}}$	31	31	31				
146.588	315	0.07	M_2	81	166	208				
			c	3.4	1.7	1.4				
			$n_{2 \text{ Eck}}$	28	28	28				
			$n_{2 \text{ th}}$	28	28	28				

$M \dots$ [Nm]
 $n \dots$ [min^{-1}]
 $J \dots$ [kgcm^2]

$P \dots$ [kW]
 $I \dots$ [A]
 $i \dots$ [-]
 $c \dots$ [-]

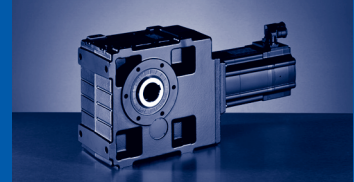

$M_{2GN} \leq 331 \text{ Nm}$

12DC20	12DC41	12HC15	12HC30	12HC35	12LC20	12LC41	GKS05-3S			
...500	...500	...500	...500	...500	...500	...500				
5.5	4.3	10	8	7.5	13.5	11	M_1	J_G	M_{2GN}	i
1950	4050	1500	3000	3525	1950	4050	n_1			
5.2	8.8	7.6	10.5		11.8		I_{M230}			
2.6	4.5	3.8		5.7	5.9	10.2	I_{M400}			
1.1	1.8	1.6	2.5	2.8	2.8	4.7	P_N			
4.12	4.12	7.42	7.42	7.42	10.72	10.72	J_M			
192	150						M_2			
1.4	1.4						c	0.58	302	36.894
53	110						$n_{2 \text{ Eck}}$			
53	79						$n_{2 \text{ th}}$			
217	170						M_2			
1.4	1.4						c	0.42	331	41.765
47	97						$n_{2 \text{ Eck}}$			
47	81						$n_{2 \text{ th}}$			
245	192						M_2			
1.2	1.3						c	0.41	304	47.059
41	86						$n_{2 \text{ Eck}}$			
41	70						$n_{2 \text{ th}}$			
267	208						M_2			
1.2	1.3						c	0.32	331	51.162
38	79						$n_{2 \text{ Eck}}$			
38	72						$n_{2 \text{ th}}$			
301	235						M_2			
1	1.1						c	0.32	307	57.647
34	70						$n_{2 \text{ Eck}}$			
34	60						$n_{2 \text{ th}}$			
							M_2			
							c	0.2	331	66.592
							$n_{2 \text{ Eck}}$			
							$n_{2 \text{ th}}$			
							M_2			
							c	0.2	310	75.033
							$n_{2 \text{ Eck}}$			
							$n_{2 \text{ th}}$			
							M_2			
							c	0.14	331	82.833
							$n_{2 \text{ Eck}}$			
							$n_{2 \text{ th}}$			
							M_2			
							c	0.14	315	93.333
							$n_{2 \text{ Eck}}$			
							$n_{2 \text{ th}}$			
							M_2			
							c	0.09	331	107.196
							$n_{2 \text{ Eck}}$			
							$n_{2 \text{ th}}$			
							M_2			
							c	0.09	315	120.784
							$n_{2 \text{ Eck}}$			
							$n_{2 \text{ th}}$			
							M_2			
							c	0.07	331	130.097
							$n_{2 \text{ Eck}}$			
							$n_{2 \text{ th}}$			
							M_2			
							c	0.07	315	146.588
							$n_{2 \text{ Eck}}$			
							$n_{2 \text{ th}}$			

M ... [Nm]
n ... [min⁻¹]
J ... [kgcm²]

P ... [kW]
I ... [A]
i [-]
c [-]

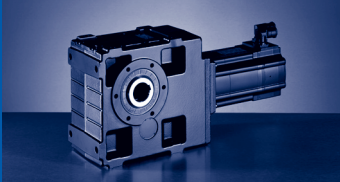

GKS [Nm]

GKS□□-□S (MCS)

$M_{2GN} \leq 331 \text{ Nm}$

GKS05-3S				06CC41	06FC41	06IC41	09DC41	09FC38	09HC41	09LC41
				...S00	...S00	...S00	...S00	...S00	...S00	...S00
i	M_{2GN}	J_G	M_1	0.6	1.2	1.5	2.3	3.1	3.8	4.5
			n_1	4050	4050	4050	4050	3750	4050	4050
			I_{M230}	2.6	2.9	3.2	4.6	5	6.8	8.4
			I_{M400}	1.3	1.5	1.6	2.3	2.5	3.4	4.2
			P_N	0.25	0.51	0.64	1	1.2	1.6	1.9
			J_M	0.17	0.25	0.33	1.13	1.53	1.93	2.83
211.2	314	0.08	M_2	119	240					
			c	2.4	1.2					
			$n_{2 \text{ Eck}}$	19	19					
			$n_{2 \text{ th}}$	19	19					
227.484	278	0.06	M_2	128						
			c	1.9						
			$n_{2 \text{ Eck}}$	18						
			$n_{2 \text{ th}}$	18						
256.32	313	0.06	M_2	145						
			c	1.9						
			$n_{2 \text{ Eck}}$	16						
			$n_{2 \text{ th}}$	16						

$M \dots$ [Nm]
 $n \dots$ [min^{-1}]
 $J \dots$ [kgcm^2]

$P \dots$ [kW]
 $I \dots$ [A]
 i [-]
 c [-]

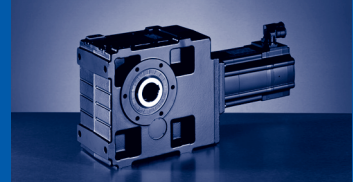

$M_{2GN} \leq 331 \text{ Nm}$

12DC20	12DC41	12HC15	12HC30	12HC35	12LC20	12LC41	GKS05-3S			
...500	...500	...500	...500	...500	...500	...500	M_1	J_G	M_{2GN}	i
5.5	4.3	10	8	7.5	13.5	11	n_1			
1950	4050	1500	3000	3525	1950	4050	I_{M230}			
5.2	8.8	7.6	10.5		11.8		I_{M400}			
2.6	4.5	3.8		5.7	5.9	10.2	P_N			
1.1	1.8	1.6	2.5	2.8	2.8	4.7	J_M			
4.12	4.12	7.42	7.42	7.42	10.72	10.72	M_2 c $n_{2 \text{ Eck}}$ $n_{2 \text{ th}}$	0.08	314	211.2
							M_2 c $n_{2 \text{ Eck}}$ $n_{2 \text{ th}}$	0.06	278	227.484
							M_2 c $n_{2 \text{ Eck}}$ $n_{2 \text{ th}}$	0.06	313	256.32

$M \dots$ [Nm]
 $n \dots$ [min^{-1}]
 $J \dots$ [kgcm^2]

$P \dots$ [kW]
 $I \dots$ [A]
 i [-]
 c [-]

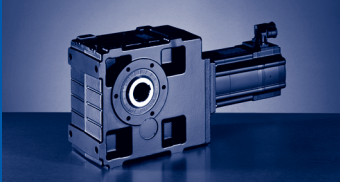

GKS [Nm]

GKS□□-□S (MCS)

$M_{2GN} \leq 331 \text{ Nm}$

GKS05-4S				06CC41	06FC41	06IC41
				...500	...500	...500
i	M_{2GN}	J_G	M_1			
			n_1	4050	4050	4050
			I_{M230}	2.6	2.9	3.2
			I_{M400}	1.3	1.5	1.6
			P_N	0.25	0.51	0.64
			J_M	0.17	0.25	0.33
95.238	167	0.14	M_2	52	106	133
			c	2.6	1.3	1
			n_2 Eck	43	43	43
			n_2 th	43	43	43
114.987	256	0.2	M_2	63	128	160
			c	3.6	1.8	1.4
			n_2 Eck	35	35	35
			n_2 th	35	35	35
126.933	283	0.2	M_2	69	141	177
			c	3.6	1.8	1.4
			n_2 Eck	32	32	32
			n_2 th	32	32	32
146.667	256	0.14	M_2	81	164	205
			c	2.8	1.4	1.1
			n_2 Eck	28	28	28
			n_2 th	28	28	28
161.905	283	0.14	M_2	89	181	226
			c	2.8	1.4	1.1
			n_2 Eck	25	25	25
			n_2 th	25	25	25
185.547	331	0.2	M_2	102	207	259
			c	2.9	1.4	1.2
			n_2 Eck	22	22	22
			n_2 th	22	22	22
209.067	315	0.2	M_2	115	234	
			c	2.4	1.2	
			n_2 Eck	19	19	
			n_2 th	19	19	
225.867	256	0.07	M_2	125		
			c	1.8		
			n_2 Eck	18		
			n_2 th	18		
236.667	331	0.14	M_2	131	265	
			c	2.3	1.1	
			n_2 Eck	17	17	
			n_2 th	17	17	
289.917	331	0.11	M_2	161		
			c	1.8		
			n_2 Eck	14		
			n_2 th	14		
326.667	315	0.11	M_2	182		
			c	1.6		
			n_2 Eck	12		
			n_2 th	12		
364.467	331	0.07	M_2	203		
			c	1.4		
			n_2 Eck	11		
			n_2 th	11		
410.667	315	0.07	M_2	229		
			c	1.2		
			n_2 Eck	10		
			n_2 th	10		

$M \dots$ [Nm]
 $n \dots$ [min^{-1}]
 $J \dots$ [kgcm^2]

$P \dots$ [kW]
 $I \dots$ [A]
 $i \dots$ [-]
 $c \dots$ [-]

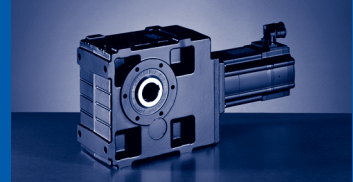

$M_{2GN} \leq 331 \text{ Nm}$

GKS05-4S				06CC41	06FC41	06IC41
				...S00	...S00	...S00
i	M_{2GN}	J_G	M_1	0.6	1.2	1.5
			n_1	4050	4050	4050
			I_{M230}	2.6	2.9	3.2
			I_{M400}	1.3	1.5	1.6
			P_N	0.25	0.51	0.64
			J_M	0.17	0.25	0.33
469.389	331	0.05	M_2	263		
			c	1.1		
			$n_{2 \text{ Eck}}$	9		
			$n_{2 \text{ th}}$	9		

M ... [Nm]
n ... [min^{-1}]
J ... [kgcm^2]

P ... [kW]
I ... [A]
i [-]
c [-]

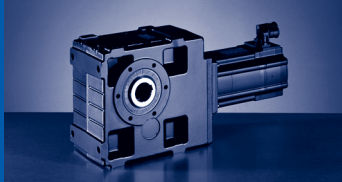

GKS [Nm]

GKS□□-□S (MCS)

$M_{2GN} \leq 702 \text{ Nm}$

GKS06-3S				06CC41	06FC41	06IC41	09DC41	09FC38	09HC41	09LC41	12DC20	12DC41	12HC15	12HC30	
				...S00	...S00	...S00	...S00	...S00	...S00	...S00	...S00	...S00	...S00	...S00	
i	M_{2GN}	J_G	M_1	0.6	1.2	1.5	2.3	3.1	3.8	4.5	5.5	4.3	10	8	
			n_1	4050	4050	4050	4050	3750	4050	4050	1950	4050	1500	3000	
			I_{M230}	2.6	2.9	3.2	4.6	5	6.8	8.4	5.2	8.8	7.6	10.5	
			I_{M400}	1.3	1.5	1.6	2.3	2.5	3.4	4.2	2.6	4.5	3.8		
			P_N	0.25	0.51	0.64	1	1.2	1.6	1.9	1.1	1.8	1.6	2.5	
			J_M	0.17	0.25	0.33	1.13	1.53	1.93	2.83	4.12	4.12	7.42	7.42	
6.485	263	5.87	M_2										59	48	
			c										4.3	4.2	
			n_2 Eck											231	463
			n_2 th											231	381
9.196	373	5.05	M_2										84	67	
			c										4.3	4.2	
			n_2 Eck											163	326
			n_2 th											163	269
10.147	412	4.86	M_2										93	74	
			c										4.3	4.2	
			n_2 Eck											148	296
			n_2 th											148	244
11.382	331	2.49	M_2						39	47	57	44	106	85	
			c						5.8	4.9	5.1	5.1	3.1	3	
			n_2 Eck						356	356	171	356	132	264	
			n_2 th						309	300	171	302	132	264	
12.612	426	3.2	M_2								62	49	117	93	
			c								5.9	5.9	3.6	3.5	
			n_2 Eck								155	321	119	238	
			n_2 th								155	243	119	219	
14.824	600	4.29	M_2										136	109	
			c										4.3	4.2	
			n_2 Eck										101	202	
			n_2 th										101	167	
16.699	604	4.16	M_2										154	123	
			c										3.8	3.8	
			n_2 Eck										90	180	
			n_2 th										90	144	
17.809	518	2.13	M_2						61	73	89	70	165	132	
			c						5.8	4.9	5.1	5.1	3.1	3	
			n_2 Eck						227	227	110	227	84	169	
			n_2 th						198	192	109	193	84	168	
20.329	665	2.79	M_2								101	79	188	151	
			c								5.7	5.8	3.5	3.4	
			n_2 Eck								96	199	74	148	
			n_2 th								96	150	74	135	
22.902	606	2.73	M_2								115	90	213	171	
			c								4.6	4.7	2.8	2.8	
			n_2 Eck								85	177	66	131	
			n_2 th								85	128	66	115	
26.017	679	1.94	M_2						90	107	131	102	243	194	
			c						5.2	4.4	4.6	4.6	2.8	2.7	
			n_2 Eck						156	156	75	156	58	115	
			n_2 th						133	128	75	130	58	115	
28.461	682	1.67	M_2					79	99	118	144	112	266	213	
			c					6	4.8	4	4.2	4.2	2.5	2.5	
			n_2 Eck					132	142	142	69	142	53	105	
			n_2 th					128	123	119	69	120	53	105	
32.063	610	1.63	M_2					91	112	134	163	128	301	241	
			c					4.8	3.8	3.2	3.3	3.4	2	2	
			n_2 Eck					117	126	126	61	126	47	94	
			n_2 th					109	105	101	61	102	47	92	

$M \dots$ [Nm]
 $n \dots$ [min^{-1}]
 $J \dots$ [kgcm^2]

$P \dots$ [kW]
 $I \dots$ [A]
 $i \dots$ [-]
 $c \dots$ [-]

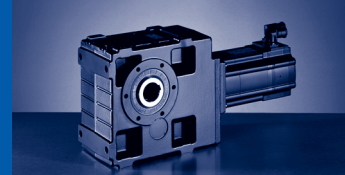

$M_{2GN} \leq 702 \text{ Nm}$

12HC35	12LC20	12LC41	14DC15	14DC36	14HC15	14HC32	14LC15	14LC32	14PC14	14PC32	GKS06-3S				
...S00	...S00	...S00	...S00	...S00	...S00	...S00	...S00	...S00	...S00	...S00	M_1	J_G	M_{2GN}	i	
7.5	13.5	11	9.2	7.5	16	14	23	17.2	30	21	n_1				
3525	1950	4050	1500	3600	1500	3225	1500	3225	1350	3225	I_{M230}				
	11.8										I_{M400}				
5.7	5.9	10.2	4.5	7.5	6.6	11.9	9.7	15	10.8	15.6	P_N				
2.8	2.8	4.7	1.45	2.8	2.5	4.7	3.6	5.8	4.2	7.1	J_M				
7.42	10.72	10.72	8.22	8.22	14.32	14.32	23.44	23.44	34.74	34.82	M_2				
45	82	66	55	45	97	85	140	105	184	129	c	5.87	263	6.485	
4.3	2.9	2.8	4.6	4.3	2.7	2.4	1.9	1.9	1.4	1.6	$n_{2\text{Eck}}$				
544	301	625	231	555	231	497	231	497	208	497	$n_{2\text{th}}$				
382	301	348	231	381	231	335	231	317	208	282	M_2				
63	116	94	77	63	137	121	199	149	261	182	c	5.05	373	9.196	
4.3	2.9	2.8	4.6	4.3	2.7	2.4	1.9	1.9	1.4	1.6	$n_{2\text{Eck}}$				
383	212	440	163	392	163	351	163	351	147	351	$n_{2\text{th}}$				
269	212	246	163	269	163	236	163	223	147	199	M_2				
70	128	104	85	70	152	133	220	164	288	201	c	4.86	412	10.147	
4.3	2.9	2.8	4.6	4.3	2.7	2.4	1.9	1.9	1.4	1.6	$n_{2\text{Eck}}$				
347	192	399	148	355	148	318	148	318	133	318	$n_{2\text{th}}$				
244	192	222	148	244	148	214	148	202	133	180	M_2				
79	144	118	97	79	171	150	248	185	324	227	c	2.49	331	11.382	
3.1	2.1	2	3.3	3.1	1.9	1.7	1.3	1.4	1	1.1	$n_{2\text{Eck}}$				
310	171	356	132	316	132	283	132	283	119	283	$n_{2\text{th}}$				
274	171	249	132	273	132	227	132	203	119	183	M_2				
87	159	130	107	87	189	166	274	205	359	251	c	3.2	426	12.612	
3.6	2.4	2.3	3.9	3.5	2.2	2	1.6	1.6	1.2	1.3	$n_{2\text{Eck}}$				
280	155	321	119	286	119	256	119	256	107	256	$n_{2\text{th}}$				
220	155	200	119	219	119	193	119	171	107	154	M_2				
102	186	152	125	102	221	194	321	240	421	294	c	4.29	600	14.824	
4.3	2.9	2.8	4.6	4.3	2.7	2.4	1.9	1.9	1.4	1.6	$n_{2\text{Eck}}$				
238	132	273	101	243	101	218	101	218	91	218	$n_{2\text{th}}$				
167	132	152	101	167	101	147	101	138	91	123	M_2				
115	211	172	141	115	250	219	362	271	475	332	c	4.16	604	16.699	
3.8	2.6	2.5	4.1	3.8	2.4	2.1	1.7	1.7	1.3	1.4	$n_{2\text{Eck}}$				
211	117	243	90	216	90	193	90	193	81	193	$n_{2\text{th}}$				
145	117	132	90	145	90	127	90	115	81	103	M_2				
124	226	184	152	124	268	235	388	290	507	355	c	2.13	518	17.809	
3.1	2.1	2	3.3	3.1	1.9	1.7	1.3	1.4	1	1.1	$n_{2\text{Eck}}$				
198	110	227	84	202	84	181	84	181	76	181	$n_{2\text{th}}$				
175	109	159	84	175	84	145	84	130	76	117	M_2				
141	257	210	173	141	305	268	442	330	578	404	c	2.79	665	20.329	
3.5	2.3	2.3	3.8	3.4	2.2	1.9	1.5	1.6	1.2	1.3	$n_{2\text{Eck}}$				
173	96	199	74	177	74	159	74	159	66	159	$n_{2\text{th}}$				
135	96	123	74	135	74	117	74	104	66	94	M_2				
160	291	237	196	160	345	303	499	373		457	c	2.73	606	22.902	
2.8	1.9	1.8	3	2.8	1.7	1.5	1.2	1.3		1	$n_{2\text{Eck}}$				
154	85	177	66	157	66	141	66	141		141	$n_{2\text{th}}$				
115	85	101	66	115	66	92	66	83		76	M_2				
182	331	270	223	182	392	344	567	424		519	c	1.94	679	26.017	
2.8	1.9	1.8	3	2.7	1.7	1.5	1.2	1.2		1	$n_{2\text{Eck}}$				
136	75	156	58	138	58	124	58	124		124	$n_{2\text{th}}$				
117	75	103	58	117	58	94	58	84		76	M_2				
199	362	295	244	200	430	377	621	464			c	1.67	682	28.461	
2.5	1.7	1.7	2.7	2.5	1.6	1.4	1.1	1.1			$n_{2\text{Eck}}$				
124	69	142	53	127	53	113	53	113			$n_{2\text{th}}$				
109	69	93	53	109	53	85	53	77			M_2				
226	410	334	277	226	486	426					c	1.63	610	32.063	
2	1.4	1.3	2.2	2	1.3	1.1					$n_{2\text{Eck}}$				
110	61	126	47	112	47	101					$n_{2\text{th}}$				
92	61	73	47	92	47	68									

$M \dots$ [Nm]
 $n \dots$ [min^{-1}]
 $J \dots$ [kgcm^2]

$P \dots$ [kW]
 $I \dots$ [A]
 $i [-]$
 $c [-]$

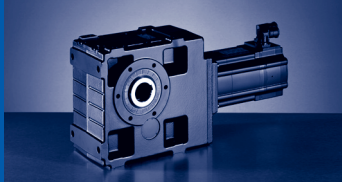

GKS [Nm]

GKS□□-□S (MCS)

$M_{2GN} \leq 702 \text{ Nm}$

GKS06-3S				06CC41	06FC41	06IC41	09DC41	09FC38	09HC41	09LC41	12DC20	12DC41	12HC15	12HC30	
				...S00	...S00	...S00	...S00	...S00	...S00	...S00	...S00	...S00	...S00	...S00	
i	M_{2GN}	J_G	M_1	0.6	1.2	1.5	2.3	3.1	3.8	4.5	5.5	4.3	10	8	
			n_1	4050	4050	4050	4050	3750	4050	4050	1950	4050	1500	3000	
			I_{M230}	2.6	2.9	3.2	4.6	5	6.8	8.4	5.2	8.8	7.6	10.5	
			I_{M400}	1.3	1.5	1.6	2.3	2.5	3.4	4.2	2.6	4.5	3.8		
			P_N	0.25	0.51	0.64	1	1.2	1.6	1.9	1.1	1.8	1.6	2.5	
			J_M	0.17	0.25	0.33	1.13	1.53	1.93	2.83	4.12	4.12	7.42	7.42	
36.303	685	1.18	M_2					103	127	152	185	145	341	273	
			c					4.7	3.8	3.2	3.3	3.3	2	2	
			n_2 Eck					103	112	112	54	112	41	83	83
			n_2 th					103	102	99	54	100	41	83	83
41.472	689	2.11	M_2								212	166	391	313	
			c								2.9	2.9	1.8	1.7	
			n_2 Eck								47	98	36	72	
			n_2 th								47	64	36	54	
44.471	689	0.9	M_2				92	126	156	186	228	178	420	335	
			c				5.8	4.4	3.5	3	3	3.1	1.6	1.8	
			n_2 Eck				91	84	91	91	44	91	34	68	
			n_2 th				91	84	91	91	44	91	34	67	
53.074	695	1.52	M_2				111	152	188	223	273	213	502	401	
			c				4.9	3.7	3	2.5	2.5	2.6	1.4	1.6	
			n_2 Eck				76	71	76	76	37	76	28	57	
			n_2 th				64	61	58	56	37	57	28	46	
57.882	695	0.58	M_2				122	166	205	244	298	233	548	438	
			c				4.5	3.4	2.7	2.3	2.3	2.4	1.3	1.4	
			n_2 Eck				70	65	70	70	34	70	26	52	
			n_2 th				70	65	70	70	34	70	26	52	
65.207	624	0.57	M_2			89	139	189	232	276	338	264	619	495	
			c			5.5	3.6	2.7	2.2	1.8	1.8	1.9	1	1.1	
			n_2 Eck			62	62	58	62	62	30	62	23	46	
			n_2 th			62	62	58	62	62	30	62	23	46	
72	666	0.42	M_2			98									
			c			5.3									
			n_2 Eck			56									
			n_2 th			56									
72	702	0.42	M_2				153	208	257	305	373	291	684	546	
			c				3.6	2.8	2.2	1.9	1.9	2	1	1.2	
			n_2 Eck				56	52	56	56	27	56	21	42	
			n_2 th				56	52	56	56	27	56	21	42	
81.111	630	0.42	M_2		88	111	174	236	290	345	422	329			
			c		5.6	4.5	2.9	2.2	1.8	1.5	1.5	1.6			
			n_2 Eck		50	50	50	46	50	50	24	50			
			n_2 th		50	50	50	46	50	50	24	50			
93.176	691	0.26	M_2		101	128									
			c		5.3	4.3									
			n_2 Eck		44	44									
			n_2 th		43	43									
93.176	702	0.26	M_2				200	271	334	396					
			c				2.8	2.1	1.7	1.4					
			n_2 Eck				44	40	44	44					
			n_2 th				43	40	43	43					
104.967	635	0.25	M_2		115	146	226	307	377	448					
			c		4.3	3.5	2.3	1.7	1.4	1.2					
			n_2 Eck		39	39	39	36	39	39					
			n_2 th		39	39	39	36	39	39					
113.082	700	0.19	M_2		124	156									
			c		4.9	3.9									
			n_2 Eck		36	36									
			n_2 th		36	36									

$M \dots$ [Nm]
 $n \dots$ [min^{-1}]
 $J \dots$ [kgcm^2]

$P \dots$ [kW]
 $I \dots$ [A]
 $i \dots$ [-]
 $c \dots$ [-]

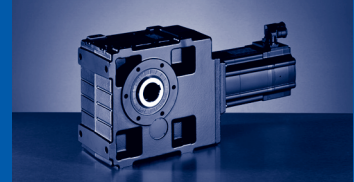

$M_{2GN} \leq 702 \text{ Nm}$

12HC35	12LC20	12LC41	14DC15	14DC36	14HC15	14HC32	14LC15	14LC32	14PC14	14PC32	GKS06-3S			
...S00	...S00	...S00	...S00	...S00	...S00	...S00	...S00	...S00	...S00	...S00	M_1	J_G	M_{2GN}	i
7.5	13.5	11	9.2	7.5	16	14	23	17.2	30	21	n_1			
3525	1950	4050	1500	3600	1500	3225	1500	3225	1350	3225	I_{M230}			
	11.8										I_{M400}			
5.7	5.9	10.2	4.5	7.5	6.6	11.9	9.7	15	10.8	15.6	P_N			
2.8	2.8	4.7	1.45	2.8	2.5	4.7	3.6	5.8	4.2	7.1	J_M			
7.42	10.72	10.72	8.22	8.22	14.32	14.32	23.44	23.44	34.74	34.82	M_2			
256	464	378	313	256	550	482					c			
2	1.4	1.3	2.2	2	1.2	1.1					$n_{2 \text{ Eck}}$	1.18	685	36.303
97	54	112	41	99	41	89					$n_{2 \text{ th}}$			
91	54	74	41	91	41	69					M_2			
293	531	433	359	293	630						c			
1.8	1.2	1.1	1.9	1.7	1.1						$n_{2 \text{ Eck}}$	2.11	689	41.472
85	47	98	36	87	36						$n_{2 \text{ th}}$			
55	45	44	36	55	36						M_2			
314	569	464	385	314	676	591					c			
1.9	1.2	1.2	1.8	1.9	1	1					$n_{2 \text{ Eck}}$	0.9	689	44.471
79	44	91	34	81	34	73					$n_{2 \text{ th}}$			
79	44	68	34	81	34	63					M_2			
376	680	554	461	376							c			
1.6	1	1	1.5	1.6							$n_{2 \text{ Eck}}$	1.52	695	53.074
66	37	76	28	68							$n_{2 \text{ th}}$			
47	37	38	28	47							M_2			
410											c			
1.4											$n_{2 \text{ Eck}}$	0.58	695	57.882
61											$n_{2 \text{ th}}$			
61											M_2			
464											c			
1.2											$n_{2 \text{ Eck}}$	0.57	624	65.207
54											$n_{2 \text{ th}}$			
54											M_2			
											c			
											$n_{2 \text{ Eck}}$	0.42	666	72
											$n_{2 \text{ th}}$			
512											M_2			
1.2											c			
49											$n_{2 \text{ Eck}}$	0.42	702	72
49											$n_{2 \text{ th}}$			
											M_2			
											c			
											$n_{2 \text{ Eck}}$	0.42	630	81.111
											$n_{2 \text{ th}}$			
											M_2			
											c			
											$n_{2 \text{ Eck}}$	0.26	691	93.176
											$n_{2 \text{ th}}$			
											M_2			
											c			
											$n_{2 \text{ Eck}}$	0.26	702	93.176
											$n_{2 \text{ th}}$			
											M_2			
											c			
											$n_{2 \text{ Eck}}$	0.25	635	104.967
											$n_{2 \text{ th}}$			
											M_2			
											c			
											$n_{2 \text{ Eck}}$	0.19	700	113.082
											$n_{2 \text{ th}}$			

$M \dots$ [Nm]
 $n \dots$ [min^{-1}]
 $J \dots$ [kgcm^2]

$P \dots$ [kW]
 $I \dots$ [A]
 i [-]
 c [-]

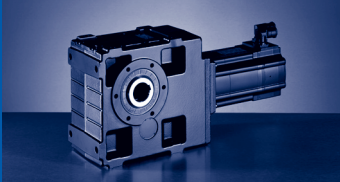

GKS [Nm]

GKS□□-□S (MCS)

$M_{2GN} \leq 702 \text{ Nm}$

GKS06-3S				06CC41	06FC41	06IC41	09DC41	09FC38	09HC41	09LC41	12DC20	12DC41	12HC15	12HC30
				...S00	...S00	...S00	...S00	...S00	...S00	...S00	...S00	...S00	...S00	...S00
i	M_{2GN}	J_G	M_1	0.6	1.2	1.5	2.3	3.1	3.8	4.5	5.5	4.3	10	8
			n_1	4050	4050	4050	4050	3750	4050	4050	1950	4050	1500	3000
			I_{M230}	2.6	2.9	3.2	4.6	5	6.8	8.4	5.2	8.8	7.6	10.5
			I_{M400}	1.3	1.5	1.6	2.3	2.5	3.4	4.2	2.6	4.5	3.8	
			P_N	0.25	0.51	0.64	1	1.2	1.6	1.9	1.1	1.8	1.6	2.5
			J_M	0.17	0.25	0.33	1.13	1.53	1.93	2.83	4.12	4.12	7.42	7.42
113.082	702	0.19	M_2				243	330	406	482				
			c				2.6	2	1.6	1.3				
			n_2 Eck				36	33	36	36				
			n_2 th				36	33	36	36				
127.392	635	0.19	M_2		141	177	275	373	459	544				
			c		4	3.2	2.1	1.6	1.3	1.1				
			n_2 Eck		32	32	32	29	32	32				
			n_2 th		32	32	32	29	32	32				
142.941	691	0.12	M_2		158	199								
			c		3.8	3.1								
			n_2 Eck		28	28								
			n_2 th		28	28								
161.029	635	0.12	M_2		179	226								
			c		3.1	2.5								
			n_2 Eck		25	25								
			n_2 th		25	25								
190.08	702	0.23	M_2	103	212	267	413	559						
			c	5.9	2.9	2.4	1.5	1.2						
			n_2 Eck	21	21	21	21	20						
			n_2 th	21	21	21	21	20						
214.133	635	0.23	M_2	117	241	302	467							
			c	4.7	2.4	1.9	1.2							
			n_2 Eck	19	19	19	19							
			n_2 th	19	19	19	19							
230.688	702	0.17	M_2	126	259	325	503							
			c	4.8	2.4	1.9	1.3							
			n_2 Eck	18	18	18	18							
			n_2 th	18	18	18	18							
259.88	635	0.17	M_2	144	293	368	568							
			c	3.9	1.9	1.6	1							
			n_2 Eck	16	16	16	16							
			n_2 th	16	16	16	16							
291.6	702	0.11	M_2	161	329	413								
			c	3.8	1.9	1.5								
			n_2 Eck	14	14	14								
			n_2 th	14	14	14								
328.5	635	0.11	M_2	183	372	467								
			c	3.1	1.5	1.2								
			n_2 Eck	12	12	12								
			n_2 th	12	12	12								

M ... [Nm]
 n ... [min⁻¹]
 J ... [kgcm²]

P ... [kW]
 I ... [A]
 i [-]
 c [-]

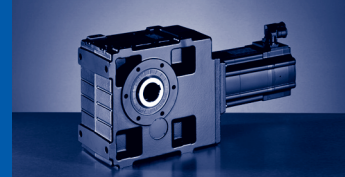

$M_{2GN} \leq 702 \text{ Nm}$

12HC35	12LC20	12LC41	14DC15	14DC36	14HC15	14HC32	14LC15	14LC32	14PC14	14PC32	GKS06-3S			
...S00	...S00	...S00	...S00	...S00	...S00	...S00	...S00	...S00	...S00	...S00	M_1	J_G	M_{2GN}	i
7.5	13.5	11	9.2	7.5	16	14	23	17.2	30	21	n_1			
3525	1950	4050	1500	3600	1500	3225	1500	3225	1350	3225	I_{M230}			
	11.8										I_{M400}			
5.7	5.9	10.2	4.5	7.5	6.6	11.9	9.7	15	10.8	15.6	P_N			
2.8	2.8	4.7	1.45	2.8	2.5	4.7	3.6	5.8	4.2	7.1	J_M			
7.42	10.72	10.72	8.22	8.22	14.32	14.32	23.44	23.44	34.74	34.82	M_2			
											c	0.19	702	113.082
											$n_{2 \text{ Eck}}$			
											$n_{2 \text{ th}}$			
											M_2	0.19	635	127.392
											c			
											$n_{2 \text{ Eck}}$			
											$n_{2 \text{ th}}$			
											M_2	0.12	691	142.941
											c			
											$n_{2 \text{ Eck}}$			
											$n_{2 \text{ th}}$			
											M_2	0.12	635	161.029
											c			
											$n_{2 \text{ Eck}}$			
											$n_{2 \text{ th}}$			
											M_2	0.23	702	190.08
											c			
											$n_{2 \text{ Eck}}$			
											$n_{2 \text{ th}}$			
											M_2	0.23	635	214.133
											c			
											$n_{2 \text{ Eck}}$			
											$n_{2 \text{ th}}$			
											M_2	0.17	702	230.688
											c			
											$n_{2 \text{ Eck}}$			
											$n_{2 \text{ th}}$			
											M_2	0.17	635	259.88
											c			
											$n_{2 \text{ Eck}}$			
											$n_{2 \text{ th}}$			
											M_2	0.11	702	291.6
											c			
											$n_{2 \text{ Eck}}$			
											$n_{2 \text{ th}}$			
											M_2	0.11	635	328.5
											c			
											$n_{2 \text{ Eck}}$			
											$n_{2 \text{ th}}$			

M ... [Nm]
n ... [min⁻¹]
J ... [kgcm²]

P ... [kW]
I ... [A]
i [-]
c [-]

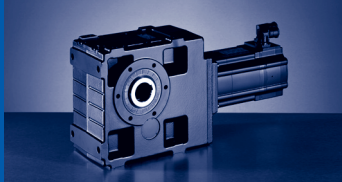

GKS [Nm]

GKS□□-□S (MCS)

$M_{2GN} \leq 702 \text{ Nm}$

GKS06-4S				06CC41	06FC41	06IC41	09DC41	09FC38	09HC41	09LC41
				...500	...500	...500	...500	...500	...500	...500
i	M_{2GN}	J_G	M_1	0.6	1.2	1.5	2.3	3.1	3.8	4.5
			n_1	4050	4050	4050	4050	3750	4050	4050
			I_{M230}	2.6	2.9	3.2	4.6	5	6.8	8.4
			I_{M400}	1.3	1.5	1.6	2.3	2.5	3.4	4.2
			P_N	0.25	0.51	0.64	1	1.2	1.6	1.9
			J_M	0.17	0.25	0.33	1.13	1.53	1.93	2.83
103.721	685	0.3	M_2		111	141	219	297	366	434
			c		4.8	3.9	2.5	1.9	1.5	1.3
			$n_{2 \text{ Eck}}$		39	39	39	36	39	39
			$n_{2 \text{ th}}$		39	39	39	36	39	39
113.205	537	0.23	M_2		123	155	241	326	401	476
			c		3.8	3.1	2	1.5	1.2	1
			$n_{2 \text{ Eck}}$		36	36	36	33	36	36
			$n_{2 \text{ th}}$		36	36	36	33	36	36
127.059	689	0.26	M_2		137	173	269	365	449	533
			c		4.4	3.5	2.3	1.7	1.4	1.2
			$n_{2 \text{ Eck}}$		32	32	32	30	32	32
			$n_{2 \text{ th}}$		32	32	32	30	32	32
140.816	537	0.21	M_2		154	194	300	407		
			c		3.1	2.5	1.6	1.2		
			$n_{2 \text{ Eck}}$		29	29	29	27		
			$n_{2 \text{ th}}$		29	29	29	27		
155.647	689	0.19	M_2		170	214	331	448	551	
			c		3.6	2.9	1.9	1.4	1.1	
			$n_{2 \text{ Eck}}$		26	26	26	24	26	
			$n_{2 \text{ th}}$		26	26	26	24	26	
174.336	537	0.11	M_2	94	192	242				
			c	5	2.5	2				
			$n_{2 \text{ Eck}}$	23	23	23				
			$n_{2 \text{ th}}$	23	23	23				
202.588	695	0.17	M_2	108	223	280	433	586		
			c	5.5	2.8	2.2	1.5	1.1		
			$n_{2 \text{ Eck}}$	20	20	20	20	19		
			$n_{2 \text{ th}}$	20	20	20	20	19		
224.524	537	0.07	M_2	122	249	313				
			c	3.9	1.9	1.6				
			$n_{2 \text{ Eck}}$	18	18	18				
			$n_{2 \text{ th}}$	18	18	18				
252	702	0.16	M_2	136	279	350	540			
			c	4.5	2.3	1.8	1.2			
			$n_{2 \text{ Eck}}$	16	16	16	16			
			$n_{2 \text{ th}}$	16	16	16	16			
279.286	537	0.07	M_2	153	311	390				
			c	3.1	1.6	1.2				
			$n_{2 \text{ Eck}}$	15	15	15				
			$n_{2 \text{ th}}$	15	15	15				
316.8	702	0.1	M_2	173	352	442				
			c	3.6	1.8	1.4				
			$n_{2 \text{ Eck}}$	13	13	13				
			$n_{2 \text{ th}}$	13	13	13				
361.429	537	0.06	M_2	199	404					
			c	2.4	1.2					
			$n_{2 \text{ Eck}}$	11	11					
			$n_{2 \text{ th}}$	11	11					
408	702	0.07	M_2	224	455	571				
			c	2.8	1.4	1.1				
			$n_{2 \text{ Eck}}$	10	10	10				
			$n_{2 \text{ th}}$	10	10	10				

M ... [Nm]
 n ... [min⁻¹]
 J ... [kgcm²]

P ... [kW]
 I ... [A]
 i [-]
 c [-]

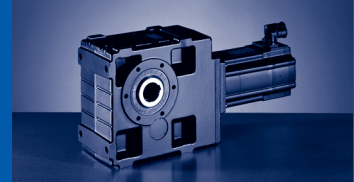

$M_{2GN} \leq 702 \text{ Nm}$

GKS06-4S				06CC41	06FC41	06IC41	09DC41	09FC38	09HC41	09LC41
				...S00	...S00	...S00	...S00	...S00	...S00	...S00
i	M_{2GN}	J_G	M_1	0.6	1.2	1.5	2.3	3.1	3.8	4.5
			n_1	4050	4050	4050	4050	3750	4050	4050
			I_{M230}	2.6	2.9	3.2	4.6	5	6.8	8.4
			I_{M400}	1.3	1.5	1.6	2.3	2.5	3.4	4.2
			P_N	0.25	0.51	0.64	1	1.2	1.6	1.9
			J_M	0.17	0.25	0.33	1.13	1.53	1.93	2.83
640.8	702	0.06	M_2	356						
			c	1.8						
			$n_{2 \text{ Eck}}$	6						
			$n_{2 \text{ th}}$	6						

M ... [Nm]
n ... [min^{-1}]
J ... [kgcm^2]

P ... [kW]
I ... [A]
i [-]
c [-]

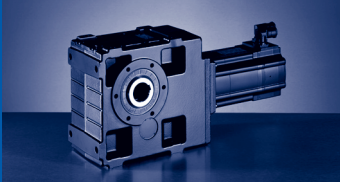

GKS [Nm]

GKS□□-□S (MCS)

$M_{2GN} \leq 1330 \text{ Nm}$

GKS07-3S				09DC41	09FC38	09HC41	09LC41	12DC20	12DC41	12HC15	12HC30	12HC35	12LC20	12LC41	14DC15
				...500	...500	...500	...500	...500	...500	...500	...500	...500	...500	...500	...500
i	M_{2GN}	J_G	M_1	2.3	3.1	3.8	4.5	5.5	4.3	10	8	7.5	13.5	11	9.2
			n_1	4050	3750	4050	4050	1950	4050	1500	3000	3525	1950	4050	1500
			I_{M230}	4.6	5	6.8	8.4	5.2	8.8	7.6	10.5		11.8		
			I_{M400}	2.3	2.5	3.4	4.2	2.6	4.5	3.8		5.7	5.9	10.2	4.5
			P_N	1	1.2	1.6	1.9	1.1	1.8	1.6	2.5	2.8	2.8	4.7	1.45
			J_M	1.13	1.53	1.93	2.83	4.12	4.12	7.42	7.42	7.42	10.72	10.72	8.22
5.955	471	19.3	M_2 c n_2 Eck n_2 th												
8.254	541	11.8	M_2 c n_2 Eck n_2 th												
9.171	725	16	M_2 c n_2 Eck n_2 th												
10.124	800	15.88	M_2 c n_2 Eck n_2 th												
11.378	515	7.02	M_2 c n_2 Eck n_2 th							104	83	78	142	116	
										4.8	4.7	4.8	3.2	3.1	
										132	264	310	171	356	
										132	257	258	171	236	
11.378	613	7.02	M_2 c n_2 Eck n_2 th												
12.711	832	10.16	M_2 c n_2 Eck n_2 th												
14.798	1040	14.31	M_2 c n_2 Eck n_2 th												
16.674	1071	13.97	M_2 c n_2 Eck n_2 th												
17.27	826	7.26	M_2 c n_2 Eck n_2 th							157	126	118	216	176	
										5	5	5.1	3.4	3.3	
										87	174	204	113	235	
										87	165	165	113	151	
17.27	998	7.26	M_2 c n_2 Eck n_2 th												
20.511	1110	9.08	M_2 c n_2 Eck n_2 th												
23.111	1168	8.91	M_2 c n_2 Eck n_2 th												192
															5.8
															65
															65

$M \dots$ [Nm]
 $n \dots$ [min^{-1}]
 $J \dots$ [kgcm^2]

$P \dots$ [kW]
 $I \dots$ [A]
 $i \dots$ [-]
 $c \dots$ [-]

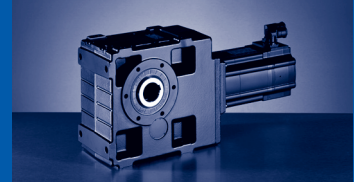

$M_{2GN} \leq 1330 \text{ Nm}$

14DC36	14HC15	14HC32	14LC15	14LC32	14PC14	14PC32	19FC14	19FC30	19JC14	19JC30	19PC14	19PC30	GKS07-3S			
...500	...500	...500	...500	...500	...500	...500	...500	...500	...500	...500	...500	...500	M_1	J_G	M_{2GN}	i
7.5	16	14	23	17.2	30	21	27	21	40	29	51	32	n_1			
3600	1500	3225	1500	3225	1350	3225	1425	3000	1425	3000	1350	3000	I_{M230}			
													I_{M400}			
7.5	6.6	11.9	9.7	15	10.8	15.6	8.6	14	12.3	18.5	14.3	19	P_N			
2.8	2.5	4.7	3.6	5.8	4.2	7.1	4	6.6	6	9.1	7.2	10	J_M			
8.22	14.32	14.32	23.44	23.44	34.74	34.82	65.12	65.04	105.04	105.12	160.12	160.04	M_2			
	87	76	127	94	167	116	149	116	224	162	287	179	c	19.3	471	5.955
	5.2	4.6	3.6	3.8	2.8	3.1	3.1	3.1	2.1	2.3	1.6	2.1	$n_2 \text{ Eck}$			
	252	542	252	542	227	542	239	504	239	504	227	504	$n_2 \text{ th}$			
	252	361	252	345	227	329	239	331	239	305	227	298				
	121	107	177	132	232	162	208	162	311	225	398	249	M_2			
	4.3	3.8	3	3.1	2.3	2.5	2.6	2.6	1.7	1.9	1.4	1.7	c	11.8	541	8.254
	182	391	182	391	164	391	173	364	173	364	164	364	$n_2 \text{ Eck}$			
	182	288	182	275	164	263	173	265	173	241	164	227	$n_2 \text{ th}$			
	133	117	195	145	256	179	230	179	344	249	441	276	M_2			
	5.2	4.6	3.6	3.8	2.8	3.1	3.1	3.1	2.1	2.3	1.6	2.1	c	16	725	9.171
	164	352	164	352	147	352	155	327	155	327	147	327	$n_2 \text{ Eck}$			
	164	234	164	224	147	214	155	215	155	198	147	193	$n_2 \text{ th}$			
	147	130	215	161	283	198	254	197	380	275	487	304	M_2			
	5.2	4.6	3.6	3.8	2.8	3.1	3.1	3.1	2.1	2.3	1.6	2.1	c	15.88	800	10.124
	148	319	148	319	133	319	141	296	141	296	133	296	$n_2 \text{ Eck}$			
	148	212	148	203	133	194	141	195	141	180	133	175	$n_2 \text{ th}$			
													M_2			
													c	7.02	515	11.378
													$n_2 \text{ Eck}$			
													$n_2 \text{ th}$			
77	168	148	245	183	321	224	288	224	430	312	551	344	M_2			
5.7	3.6	3.1	2.5	2.6	1.9	2.1	2.1	2.1	1.4	1.6	1.1	1.4	c	7.02	613	11.378
316	132	284	132	284	119	284	125	264	125	264	119	264	$n_2 \text{ Eck}$			
266	132	237	132	226	119	216	125	194	125	186	119	177	$n_2 \text{ th}$			
	186	164	272	203	357	249	321	249	479	347	613	383	M_2			
	4.3	3.8	3	3.1	2.3	2.5	2.6	2.6	1.7	1.9	1.4	1.7	c	10.16	832	12.711
	118	254	118	254	106	254	112	236	112	236	106	236	$n_2 \text{ Eck}$			
	118	187	118	179	106	171	112	172	112	157	106	148	$n_2 \text{ th}$			
	216	190	316	236	415	290	373	290	557	403	713	446	M_2			
	4.6	4.1	3.2	3.3	2.5	2.7	2.7	2.8	1.9	2	1.5	1.8	c	14.31	1040	14.798
	101	218	101	218	91	218	96	203	96	203	91	203	$n_2 \text{ Eck}$			
	101	142	101	135	91	129	96	129	96	119	91	113	$n_2 \text{ th}$			
	245	215	357	267	469	327	421	327	629	455	805	503	M_2			
	4.2	3.7	2.9	3.1	2.3	2.5	2.5	2.6	1.7	1.9	1.3	1.7	c	13.97	1071	16.674
	90	193	90	193	81	193	86	180	86	180	81	180	$n_2 \text{ Eck}$			
	90	123	90	117	81	112	85	112	85	101	81	95	$n_2 \text{ th}$			
													M_2			
													c	7.26	826	17.27
													$n_2 \text{ Eck}$			
													$n_2 \text{ th}$			
	255	224	371	277	487	340	437	340	653	472	835	522	M_2			
	3.8	3.4	2.7	2.7	2	2.3	2.3	2.3	1.5	1.7	1.2	1.5	c	7.26	998	17.27
	87	187	87	187	78	187	83	174	83	174	78	174	$n_2 \text{ Eck}$			
	87	152	87	145	78	138	83	128	83	121	78	114	$n_2 \text{ th}$			
139	303	267	441	330	579	404	520	404	776	562	992	621	M_2			
5.7	3.6	3.2	2.5	2.6	1.9	2.1	2.1	2.2	1.4	1.6	1.1	1.4	c	9.08	1110	20.511
176	73	157	73	157	66	157	70	146	70	146	66	146	$n_2 \text{ Eck}$			
126	73	111	73	106	66	101	69	102	69	87	66	82	$n_2 \text{ th}$			
157	343	301	498	372	653	456	587	456	875	634	1119	700	M_2			
5.3	3.3	3	2.3	2.4	1.8	2	2	2	1.3	1.5	1	1.3	c	8.91	1168	23.111
156	65	140	65	140	58	140	62	130	62	130	58	130	$n_2 \text{ Eck}$			
110	65	97	65	93	58	88	62	89	62	74	58	70	$n_2 \text{ th}$			

M ... [Nm]
n ... [min⁻¹]
J ... [kgcm²]

P ... [kW]
I ... [A]
i [-]
c [-]

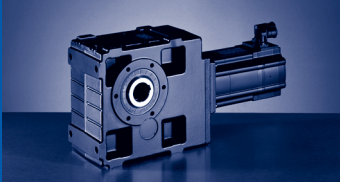

GKS [Nm]

GKS□□-□S (MCS)

$M_{2GN} \leq 1330 \text{ Nm}$

GKS07-3S				09DC41	09FC38	09HC41	09LC41	12DC20	12DC41	12HC15	12HC30	12HC35	12LC20	12LC41	14DC15	
				...500	...500	...500	...500	...500	...500	...500	...500	...500	...500	...500	...500	
i	M_{2GN}	J_G	M_1	2.3	3.1	3.8	4.5	5.5	4.3	10	8	7.5	13.5	11	9.2	
			n_1	4050	3750	4050	4050	1950	4050	1500	3000	3525	1950	4050	1500	
			I_{M230}	4.6	5	6.8	8.4	5.2	8.8	7.6	10.5		11.8			
			I_{M400}	2.3	2.5	3.4	4.2	2.6	4.5	3.8		5.7	5.9	10.2	4.5	
			P_N	1	1.2	1.6	1.9	1.1	1.8	1.6	2.5	2.8	2.8	4.7	1.45	
			J_M	1.13	1.53	1.93	2.83	4.12	4.12	7.42	7.42	7.42	10.72	10.72	8.22	
25.244	1177	6.72	M_2							230	184	172	316	258	211	
			c						4.9	4.9	4.9	3.3	3.2	5.3		
			$n_{2 \text{ Eck}}$						59	119	140	77	160	59		
			$n_{2 \text{ th}}$							59	112	112	77	103	59	
28.274	1202	5.57	M_2							259	207	194	355	289	237	
			c						4.5	4.4	4.5	3	2.9	4.9		
			$n_{2 \text{ Eck}}$						53	106	125	69	143	53		
			$n_{2 \text{ th}}$							53	102	102	69	94	53	
31.858	1172	5.47	M_2							293	235	220	402	328	269	
			c						3.9	3.8	3.9	2.6	2.5	4.2		
			$n_{2 \text{ Eck}}$						47	94	111	61	127	47		
			$n_{2 \text{ th}}$							47	88	88	61	81	47	
36.063	1068	3.65	M_2			123	148									
			c			5.9	5									
			$n_{2 \text{ Eck}}$			112	112									
			$n_{2 \text{ th}}$			99	96									
36.063	1290	3.65	M_2							333	266	249	455	371	305	
			c						3.8	3.7	3.8	2.6	2.5	4.1		
			$n_{2 \text{ Eck}}$						42	83	98	54	112	42		
			$n_{2 \text{ th}}$							42	83	91	54	83	42	
40.906	1290	6.93	M_2												348	
			c												3.6	
			$n_{2 \text{ Eck}}$												37	
			$n_{2 \text{ th}}$											37		
44.178	1300	2.78	M_2					220	171	410	327	306	559	455	376	
			c					5.6	5.9	3.1	3.5	3.5	2.3	2.3	3.4	
			$n_{2 \text{ Eck}}$					44	92	34	68	80	44	92	34	
			$n_{2 \text{ th}}$					44	87	34	68	80	44	73	34	
50.345	1300	5.3	M_2					252	197	470	374	351	639	520	431	
			c					4.9	5.2	2.7	3.1	3.1	2	2	3	
			$n_{2 \text{ Eck}}$					39	80	30	60	70	39	80	30	
			$n_{2 \text{ th}}$					39	57	30	51	51	39	46	30	
57.501	1174	1.75	M_2		161	200	238									
			c		5.8	4.6	3.9									
			$n_{2 \text{ Eck}}$		65	70	70									
			$n_{2 \text{ th}}$		65	70	70									
57.501	1310	1.75	M_2					290	226	538	429	402	731	596	494	
			c					4.4	4.6	2.4	2.7	2.7	1.8	1.8	2.6	
			$n_{2 \text{ Eck}}$					34	70	26	52	61	34	70	26	
			$n_{2 \text{ th}}$					34	70	26	52	61	34	63	26	
64.79	1195	1.73	M_2		182	226	270	329	257	609	486	456	827	674	560	
			c		5.2	4.2	3.5	3.5	3.7	1.9	2.2	2.2	1.4	1.4	2.1	
			$n_{2 \text{ Eck}}$		58	63	63	30	63	23	46	54	30	63	23	
			$n_{2 \text{ th}}$		58	63	63	30	63	23	46	54	30	50	23	
70.474	1230	1.3	M_2		199	246	294									
			c		5	4	3.3									
			$n_{2 \text{ Eck}}$		53	58	58									
			$n_{2 \text{ th}}$		53	57	57									
70.474	1320	1.3	M_2					358	280	663	529	495	899	733	608	
			c					3.6	3.7	2	2.2	2.3	1.5	1.5	2.1	
			$n_{2 \text{ Eck}}$					28	58	21	43	50	28	58	21	
			$n_{2 \text{ th}}$					28	57	21	43	50	28	53	21	

$M \dots$ [Nm]
 $n \dots$ [min^{-1}]
 $J \dots$ [kgcm^2]

$P \dots$ [kW]
 $I \dots$ [A]
 $i \dots$ [-]
 $c \dots$ [-]

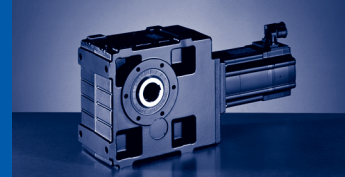

$M_{2GN} \leq 1330 \text{ Nm}$

14DC36	14HC15	14HC32	14LC15	14LC32	14PC14	14PC32	19FC14	19FC30	19JC14	19JC30	19PC14	19PC30	GKS07-3S			
...500	...500	...500	...500	...500	...500	...500	...500	...500	...500	...500	...500	...500	M_1	J_G	M_{2GN}	i
7.5	16	14	23	17.2	30	21	27	21	40	29	51	32	n_1			
3600	1500	3225	1500	3225	1350	3225	1425	3000	1425	3000	1350	3000	I_{M230}			
													I_{M400}			
7.5	6.6	11.9	9.7	15	10.8	15.6	8.6	14	12.3	18.5	14.3	19	P_N			
2.8	2.5	4.7	3.6	5.8	4.2	7.1	4	6.6	6	9.1	7.2	10	J_M			
8.22	14.32	14.32	23.44	23.44	34.74	34.82	65.12	65.04	105.04	105.12	160.12	160.04	M_2			
172	375	330	545	407	715	499	642	499	957	693		766	c	6.72	1177	25.244
4.9	3.1	2.7	2.1	2.2	1.6	1.8	1.8	1.9	1.2	1.3		119	$n_{2\text{Eck}}$			
143	59	128	59	128	54	128	57	119	57	119		70	$n_{2\text{th}}$			
112	59	99	59	94	53	87	56	88	56	73		70	M_2			
194	422	370	612	457	802	560	720	560	1073	777		858	c	5.57	1202	28.274
4.5	2.8	2.5	2	2	1.5	1.7	1.7	1.7	1.1	1.2		119	$n_{2\text{Eck}}$			
127	53	114	53	114	48	114	50	106	50	106		63	$n_{2\text{th}}$			
102	53	90	53	86	48	78	50	78	50	66		63	M_2			
220	477	419	691	516	905	633	813	632		877			c	5.47	1172	31.858
3.9	2.4	2.1	1.7	1.8	1.3	1.4	1.4	1.5		1.1			$n_{2\text{Eck}}$			
113	47	101	47	101	42	101	45	94		94			$n_{2\text{th}}$			
88	47	78	47	71	42	64	45	64		55			M_2			
													c	3.65	1068	36.063
													$n_{2\text{Eck}}$			
													$n_{2\text{th}}$			
249	540	474	783	585	1025	716							M_2			
3.8	2.4	2.1	1.6	1.7	1.3	1.4							c	3.65	1290	36.063
100	42	89	42	89	37	89							$n_{2\text{Eck}}$			
90	42	80	42	72	37	65							$n_{2\text{th}}$			
284	615	539	889	665	1164	814	1047	814					M_2			
3.3	2.1	1.8	1.4	1.5	1.1	1.2	1.2	1.3					c	6.93	1290	40.906
88	37	79	37	79	33	79	35	73					$n_{2\text{Eck}}$			
56	37	48	37	43	33	38	35	39					$n_{2\text{th}}$			
306	665	582	962	717	1258	878							M_2			
3.5	1.9	2	1.4	1.6	1	1.3							c	2.78	1300	44.178
82	34	73	34	73	31	73							$n_{2\text{Eck}}$			
79	34	71	34	63	31	58							$n_{2\text{th}}$			
351	760	664	1098	819		1003	1291	1002					M_2			
3.1	1.7	1.7	1.2	1.4		1.1	1	1.2					c	5.3	1300	50.345
72	30	64	30	64		64	28	60					$n_{2\text{Eck}}$			
51	30	42	30	37		34	28	34					$n_{2\text{th}}$			
													M_2			
													c	1.75	1174	57.501
													$n_{2\text{Eck}}$			
													$n_{2\text{th}}$			
402	869	761	1256	937		1147							M_2			
2.7	1.5	1.5	1	1.2		1							c	1.75	1310	57.501
63	26	56	26	56		56							$n_{2\text{Eck}}$			
62	26	56	26	52		48							$n_{2\text{th}}$			
456	982	860											M_2			
2.2	1.2	1.2											c	1.73	1195	64.79
56	23	50											$n_{2\text{Eck}}$			
55	23	46											$n_{2\text{th}}$			
													M_2			
													c	1.3	1230	70.474
													$n_{2\text{Eck}}$			
													$n_{2\text{th}}$			
496	1068	935		1151									M_2			
2.2	1.2	1.2		1									c	1.3	1320	70.474
51	21	46		46									$n_{2\text{Eck}}$			
51	21	46		45									$n_{2\text{th}}$			

$M \dots$ [Nm]
 $n \dots$ [min^{-1}]
 $J \dots$ [kgcm^2]

$P \dots$ [kW]
 $I \dots$ [A]
 $i [-]$
 $c [-]$

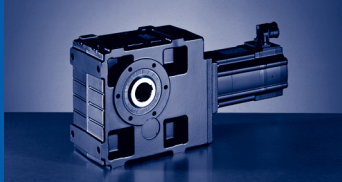

GKS [Nm]

GKS□□-□S (MCS)

$M_{2GN} \leq 1330 \text{ Nm}$

GKS07-3S				09DC41	09FC38	09HC41	09LC41	12DC20	12DC41	12HC15	12HC30	12HC35	12LC20	12LC41	14DC15
				...500	...500	...500	...500	...500	...500	...500	...500	...500	...500	...500	...500
i	M_{2GN}	J_G	M_1	2.3	3.1	3.8	4.5	5.5	4.3	10	8	7.5	13.5	11	9.2
			n_1	4050	3750	4050	4050	1950	4050	1500	3000	3525	1950	4050	1500
			I_{M230}	4.6	5	6.8	8.4	5.2	8.8	7.6	10.5		11.8		
			I_{M400}	2.3	2.5	3.4	4.2	2.6	4.5	3.8		5.7	5.9	10.2	4.5
			P_N	1	1.2	1.6	1.9	1.1	1.8	1.6	2.5	2.8	2.8	4.7	1.45
			J_M	1.13	1.53	1.93	2.83	4.12	4.12	7.42	7.42	7.42	10.72	10.72	8.22
79.407	1205	1.28	M_2	165	226	279	333	407	317	750	598	561	1016	828	689
			c	5.7	4.3	3.4	2.9	2.9	3	1.6	1.8	1.8	1.2	1.2	1.7
			$n_{2 \text{ Eck}}$	51	47	51	51	25	51	19	38	44	25	51	19
			$n_{2 \text{ th}}$	51	47	51	51	25	51	19	38	44	25	43	19
92.563	1264	0.81	M_2	193	264	327	389								
			c	5.1	3.9	3.1	2.6								
			$n_{2 \text{ Eck}}$	44	41	44	44								
			$n_{2 \text{ th}}$	44	41	44	44								
92.563	1330	0.81	M_2					475	371	874	698	654	1185	966	
			c					2.8	2.9	1.5	1.7	1.7	1.1	1.1	
			$n_{2 \text{ Eck}}$					21	44	16	32	38	21	44	
			$n_{2 \text{ th}}$					21	44	16	32	38	21	44	
104.296	1215	0.8	M_2	220	300	370	440	538	420	988	789	740			
			c	4.4	3.3	2.6	2.2	2.2	2.3	1.2	1.4	1.4			
			$n_{2 \text{ Eck}}$	39	36	39	39	19	39	14	29	34			
			$n_{2 \text{ th}}$	39	36	39	39	19	39	14	29	34			
112.338	1279	0.59	M_2	236	322	398	473								
			c	4.7	3.6	2.9	2.4								
			$n_{2 \text{ Eck}}$	36	33	36	36								
			$n_{2 \text{ th}}$	36	33	36	36								
112.338	1330	0.59	M_2					579	451	1064	849	795		1173	
			c					2.3	2.6	1.3	1.6	1.6		1	
			$n_{2 \text{ Eck}}$					17	36	13	27	31		36	
			$n_{2 \text{ th}}$					17	36	13	27	31		36	
126.578	1215	0.59	M_2	268	365	450	535	655	511	1202	959	899			
			c	4	3	2.4	2	1.8	2.1	1	1.3	1.3			
			$n_{2 \text{ Eck}}$	32	30	32	32	15	32	12	24	28			
			$n_{2 \text{ th}}$	32	30	32	32	15	32	12	24	28			
140.548	1330	1.11	M_2	298	405	500	594	728	567		1065	999			1227
			c	3.9	3	2.4	2	1.8	2.1		1.3	1.3			1.1
			$n_{2 \text{ Eck}}$	29	27	29	29	14	29		21	25			11
			$n_{2 \text{ th}}$	29	27	29	29	14	29		21	25			11
158.364	1215	1.11	M_2	338	459	566	672	823	642		1203	1128			
			c	3.2	2.4	1.9	1.6	1.5	1.7		1	1			
			$n_{2 \text{ Eck}}$	26	24	26	26	12	26		19	22			
			$n_{2 \text{ th}}$	26	24	26	25	12	25		19	20			
184.6	1330	0.69	M_2	395	536	661	785	961	749						
			c	3	2.3	1.8	1.5	1.4	1.6						
			$n_{2 \text{ Eck}}$	22	20	22	22	11	22						
			$n_{2 \text{ th}}$	22	20	22	22	11	22						
208	1215	0.69	M_2	448	607	747	887	1085	847						
			c	2.4	1.8	1.5	1.2	1.1	1.3						
			$n_{2 \text{ Eck}}$	20	18	20	20	9	20						
			$n_{2 \text{ th}}$	19	18	19	19	9	19						
224.037	1330	0.51	M_2	482	654	805	955	1169	912						
			c	2.5	1.9	1.5	1.3	1.1	1.3						
			$n_{2 \text{ Eck}}$	18	17	18	18	9	18						
			$n_{2 \text{ th}}$	18	17	18	18	9	18						
252.436	1215	0.51	M_2	546	739	909	1079		1030						
			c	2	1.5	1.2	1		1.1						
			$n_{2 \text{ Eck}}$	16	15	16	16		16						
			$n_{2 \text{ th}}$	16	15	16	16		16						

$M \dots$ [Nm]
 $n \dots$ [min^{-1}]
 $J \dots$ [kgcm^2]

$P \dots$ [kW]
 $I \dots$ [A]
 $i \dots$ [-]
 $c \dots$ [-]

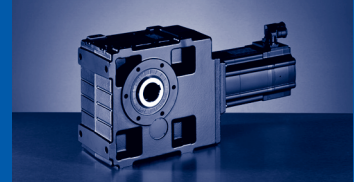

$M_{2GN} \leq 1330 \text{ Nm}$

14DC36	14HC15	14HC32	14LC15	14LC32	14PC14	14PC32	19FC14	19FC30	19JC14	19JC30	19PC14	19PC30	GKS07-3S			
...S00	...S00	...S00	...S00	...S00	...S00	...S00	...S00	...S00	...S00	...S00	...S00	...S00	M_1	J_G	M_{2GN}	i
7.5	16	14	23	17.2	30	21	27	21	40	29	51	32	n_1			
3600	1500	3225	1500	3225	1350	3225	1425	3000	1425	3000	1350	3000	I_{M230}			
7.5	6.6	11.9	9.7	15	10.8	15.6	8.6	14	12.3	18.5	14.3	19	I_{M400}			
2.8	2.5	4.7	3.6	5.8	4.2	7.1	4	6.6	6	9.1	7.2	10	P_N			
8.22	14.32	14.32	23.44	23.44	34.74	34.82	65.12	65.04	105.04	105.12	160.12	160.04	J_M			
561		1056											M_2			
1.8		1											c	1.28	1205	79.407
45		41											n_2 Eck			
45		40											n_2 th			
													M_2			
													c	0.81	1264	92.563
													n_2 Eck			
													n_2 th			
													M_2			
													c	0.81	1330	92.563
													n_2 Eck			
													n_2 th			
													M_2			
													c	0.8	1215	104.296
													n_2 Eck			
													n_2 th			
													M_2			
													c	0.59	1279	112.338
													n_2 Eck			
													n_2 th			
													M_2			
													c	0.59	1330	112.338
													n_2 Eck			
													n_2 th			
													M_2			
													c	0.59	1215	126.578
													n_2 Eck			
													n_2 th			
999													M_2			
1.3													c	1.11	1330	140.548
26													n_2 Eck			
25													n_2 th			
1128													M_2			
1													c	1.11	1215	158.364
23													n_2 Eck			
20													n_2 th			
													M_2			
													c	0.69	1330	184.6
													n_2 Eck			
													n_2 th			
													M_2			
													c	0.69	1215	208
													n_2 Eck			
													n_2 th			
													M_2			
													c	0.51	1330	224.037
													n_2 Eck			
													n_2 th			
													M_2			
													c	0.51	1215	252.436
													n_2 Eck			
													n_2 th			

$M \dots$ [Nm]
 $n \dots$ [min^{-1}]
 $J \dots$ [kgcm^2]

$P \dots$ [kW]
 $I \dots$ [A]
 i [-]
 c [-]

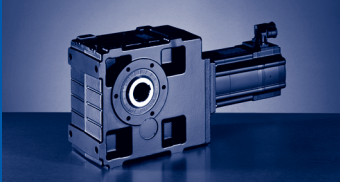

GKS [Nm]

GKS□□-□S (MCS)

$M_{2GN} \leq 1330 \text{ Nm}$

GKS07-3S				09DC41	09FC38	09HC41	09LC41	12DC20	12DC41	12HC15	12HC30	12HC35	12LC20	12LC41	14DC15	
				...S00	...S00	...S00	...S00	...S00	...S00	...S00	...S00	...S00	...S00	...S00	...S00	
i	M_{2GN}	J_G	M_1	2.3	3.1	3.8	4.5	5.5	4.3	10	8	7.5	13.5	11	9.2	
			n_1	4050	3750	4050	4050	1950	4050	1500	3000	3525	1950	4050	1500	
			I_{M230}	4.6	5	6.8	8.4	5.2	8.8	7.6	10.5		11.8			
			I_{M400}	2.3	2.5	3.4	4.2	2.6	4.5	3.8		5.7	5.9	10.2	4.5	
			P_N	1	1.2	1.6	1.9	1.1	1.8	1.6	2.5	2.8	2.8	4.7	1.45	
			J_M	1.13	1.53	1.93	2.83	4.12	4.12	7.42	7.42	7.42	10.72	10.72	8.22	
283.193	1330	0.33	M_2	613	830	1020										
			c	2	1.5	1.2										
			$n_{2 \text{ Eck}}$	14	13	14										
			$n_{2 \text{ th}}$	14	13	14										
319.091	1215	0.33	M_2	693	938											
			c	1.6	1.2											
			$n_{2 \text{ Eck}}$	13	12											
			$n_{2 \text{ th}}$	13	12											

$M \dots$ [Nm]
 $n \dots$ [min^{-1}]
 $J \dots$ [kgcm^2]

$P \dots$ [kW]
 $I \dots$ [A]
 $i \dots$ [-]
 $c \dots$ [-]

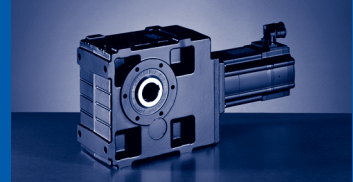

$M_{2GN} \leq 1330 \text{ Nm}$

14DC36	14HC15	14HC32	14LC15	14LC32	14PC14	14PC32	19FC14	19FC30	19JC14	19JC30	19PC14	19PC30	GKS07-3S			
...S00	...S00	...S00	...S00	...S00	...S00	...S00	...S00	...S00	...S00	...S00	...S00	...S00	M_1	J_G	M_{2GN}	i
7.5	16	14	23	17.2	30	21	27	21	40	29	51	32	n_1			
3600	1500	3225	1500	3225	1350	3225	1425	3000	1425	3000	1350	3000	I_{M230}			
7.5	6.6	11.9	9.7	15	10.8	15.6	8.6	14	12.3	18.5	14.3	19	I_{M400}			
2.8	2.5	4.7	3.6	5.8	4.2	7.1	4	6.6	6	9.1	7.2	10	P_N			
8.22	14.32	14.32	23.44	23.44	34.74	34.82	65.12	65.04	105.04	105.12	160.12	160.04	J_M			
													M_2			
													c	0.33	1330	283.193
													$n_{2 \text{ Eck}}$			
													$n_{2 \text{ th}}$			
													M_2			
													c	0.33	1215	319.091
													$n_{2 \text{ Eck}}$			
													$n_{2 \text{ th}}$			

M ... [Nm]
n ... [min⁻¹]
J ... [kgcm²]

P ... [kW]
I ... [A]
i [-]
c [-]

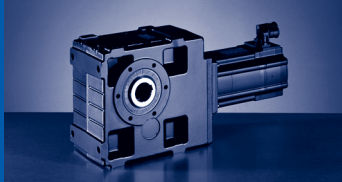

GKS [Nm]

GKS□□-□S (MCS)

$M_{2GN} \leq 1330 \text{ Nm}$

GKS07-4S				06CC41	06FC41	06IC41	09DC41	09FC38	09HC41	09LC41	12DC20	12DC41	12HC15	12HC30	12HC35	
				...500	...500	...500	...500	...500	...500	...500	...500	...500	...500	...500	...500	
i	M_{2GN}	J_G	M_1	0.6	1.2	1.5	2.3	3.1	3.8	4.5	5.5	4.3	10	8	7.5	
			n_1	4050	4050	4050	4050	3750	4050	4050	1950	4050	1500	3000	3525	
			I_{M230}	2.6	2.9	3.2	4.6	5	6.8	8.4	5.2	8.8	7.6	10.5		
			I_{M400}	1.3	1.5	1.6	2.3	2.5	3.4	4.2	2.6	4.5	3.8		5.7	
			P_N	0.25	0.51	0.64	1	1.2	1.6	1.9	1.1	1.8	1.6	2.5	2.8	
			J_M	0.17	0.25	0.33	1.13	1.53	1.93	2.83	4.12	4.12	7.42	7.42	7.42	
103.039	1290	0.84	M_2				212	290	358	426	521	407	959	765	717	
			c				4.8	3.6	2.9	2.4	2.4	2.5	1.3	1.5	1.5	
			$n_{2 \text{ Eck}}$				39	36	39	39	39	19	39	15	29	34
			$n_{2 \text{ th}}$				39	36	39	39	39	19	39	15	29	34
112.391	1053	0.63	M_2				234	318	393	467	572	446	1049	837	785	
			c				4	3	2.4	2	1.8	2.1	1	1.3	1.3	
			$n_{2 \text{ Eck}}$				36	33	36	36	36	17	36	13	27	31
			$n_{2 \text{ th}}$				36	33	36	36	36	17	36	13	27	31
126.222	1300	0.73	M_2				261	356	440	523	641	500	1177	939	880	
			c				4.3	3.3	2.6	2.2	2	2.3	1.1	1.4	1.4	
			$n_{2 \text{ Eck}}$				32	30	32	32	32	16	32	12	24	28
			$n_{2 \text{ th}}$				32	30	32	32	32	15	32	12	24	28
137.748	1053	0.57	M_2			185	289	393	484	575	704	549		1029	964	
			c			4.9	3.2	2.5	2	1.7	1.5	1.7		1	1	
			$n_{2 \text{ Eck}}$			29	29	27	29	29	14	29		22	26	
			$n_{2 \text{ th}}$			29	29	27	29	29	14	29		22	26	
154.622	1300	0.53	M_2			206	323	439	542	644	789	615		1153	1081	
			c			5.4	3.5	2.7	2.1	1.8	1.6	1.9		1.1	1.1	
			$n_{2 \text{ Eck}}$			26	26	24	26	26	13	26		19	23	
			$n_{2 \text{ th}}$			26	26	24	26	26	13	26		19	23	
179.201	1053	0.28	M_2		193	243	379	514	632	751						
			c		4.8	3.8	2.5	1.9	1.5	1.3						
			$n_{2 \text{ Eck}}$		23	23	23	21	23	23						
			$n_{2 \text{ th}}$		23	23	23	21	23	23						
201.254	1310	0.45	M_2		215	272	424	576	709	842	1031	804				
			c		5.3	4.2	2.7	2.1	1.7	1.4	1.3	1.5				
			$n_{2 \text{ Eck}}$		20	20	20	19	20	20	10	20				
			$n_{2 \text{ th}}$		20	20	20	19	20	20	10	20				
222.909	1053	0.2	M_2		242	305	474	642	789	936						
			c		3.8	3.1	2	1.5	1.2	1						
			$n_{2 \text{ Eck}}$		18	18	18	17	18	18						
			$n_{2 \text{ th}}$		18	18	18	17	18	18						
246.659	1320	0.42	M_2		267	336	523	708	872	1035	1266	988				
			c		4.3	3.5	2.3	1.7	1.4	1.2	1	1.2				
			$n_{2 \text{ Eck}}$		16	16	16	15	16	16	8	16				
			$n_{2 \text{ th}}$		16	16	16	15	16	16	8	16				
273.199	1053	0.18	M_2		299	377	583	789								
			c		3.1	2.5	1.6	1.2								
			$n_{2 \text{ Eck}}$		15	15	15	14								
			$n_{2 \text{ th}}$		15	15	15	14								
321.049	1320	0.26	M_2		351	442	684	926	1139							
			c		3.3	2.7	1.7	1.3	1.1							
			$n_{2 \text{ Eck}}$		13	13	13	12	13							
			$n_{2 \text{ th}}$		13	13	13	12	13							
358.829	1053	0.17	M_2	193	396	498	769									
			c	4.7	2.4	1.9	1.2									
			$n_{2 \text{ Eck}}$	11	11	11	11									
			$n_{2 \text{ th}}$	11	11	11	11									
399.353	1320	0.18	M_2	213	439	553	854	1155								
			c	5.3	2.7	2.1	1.4	1.1								
			$n_{2 \text{ Eck}}$	10	10	10	10	9								
			$n_{2 \text{ th}}$	10	10	10	10	9								

M ... [Nm]
 n ... [min⁻¹]
 J ... [kgcm²]

P ... [kW]
 I ... [A]
 i [-]
 c [-]

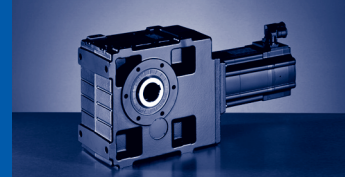

$M_{2GN} \leq 1330 \text{ Nm}$

GKS07-4S				06CC41	06FC41	06IC41	09DC41	09FC38	09HC41	09LC41	12DC20	12DC41	12HC15	12HC30	12HC35			
				...500	...500	...500	...500	...500	...500	...500	...500	...500	...500	...500	...500			
i	M_{2GN}	J_G	M_1	0.6	1.2	1.5	2.3	3.1	3.8	4.5	5.5	4.3	10	8	7.5			
			n_1	4050	4050	4050	4050	3750	4050	4050	1950	4050	1500	3000	3525			
			I_{M230}	2.6	2.9	3.2	4.6	5	6.8	8.4	5.2	8.8	7.6	10.5				
			I_{M400}	1.3	1.5	1.6	2.3	2.5	3.4	4.2	2.6	4.5	3.8		5.7			
			P_N	0.25	0.51	0.64	1	1.2	1.6	1.9	1.1	1.8	1.6	2.5	2.8			
			J_M	0.17	0.25	0.33	1.13	1.53	1.93	2.83	4.12	4.12	7.42	7.42	7.42			
464.367	1053	0.11	M_2	253	516	647												
			c	3.7	1.8	1.5												
			$n_{2 \text{ Eck}}$	9	9	9												
			$n_{2 \text{ th}}$	9	9	9												
516.81	1320	0.11	M_2	280	572	719												
			c	4.1	2.1	1.7												
			$n_{2 \text{ Eck}}$	8	8	8												
			$n_{2 \text{ th}}$	8	8	8												
563.572	1053	0.1	M_2	309	628	788												
			c	3	1.5	1.2												
			$n_{2 \text{ Eck}}$	7	7	7												
			$n_{2 \text{ th}}$	7	7	7												
636.581	1330	0.16	M_2	348	708	888												
			c	3.4	1.7	1.4												
			$n_{2 \text{ Eck}}$	6	6	6												
			$n_{2 \text{ th}}$	6	6	6												
683.972	1053	0.07	M_2	377	764													
			c	2.5	1.2													
			$n_{2 \text{ Eck}}$	6	6													
			$n_{2 \text{ th}}$	6	6													
823.81	1330	0.1	M_2	454	920	1153												
			c	2.6	1.3	1												
			$n_{2 \text{ Eck}}$	5	5	5												
			$n_{2 \text{ th}}$	5	5	5												
928.237	1215	0.1	M_2	514	1039													
			c	2.1	1.1													
			$n_{2 \text{ Eck}}$	4	4													
			$n_{2 \text{ th}}$	4	4													
999.806	1330	0.07	M_2	553	1119													
			c	2.2	1.1													
			$n_{2 \text{ Eck}}$	4	4													
			$n_{2 \text{ th}}$	4	4													
1126.542	1215	0.07	M_2	626														
			c	1.7														
			$n_{2 \text{ Eck}}$	4														
			$n_{2 \text{ th}}$	4														

$M \dots$ [Nm]
 $n \dots$ [min^{-1}]
 $J \dots$ [kgcm^2]

$P \dots$ [kW]
 $I \dots$ [A]
 $i \dots$ [-]
 $c \dots$ [-]

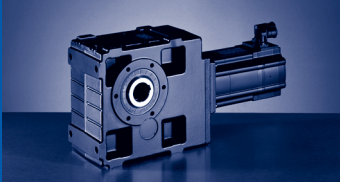

GKS [Nm]

GKS□□-□S (MCS)

$M_{2GN} \leq 3080 \text{ Nm}$

GKS09-3S				12DC20	12DC41	12HC15	12HC30	12HC35	12LC20	12LC41	14DC15	14DC36	14HC15
				...500	...500	...500	...500	...500	...500	...500	...500	...500	...500
i	M_{2GN}	J_G	M_1	5.5	4.3	10	8	7.5	13.5	11	9.2	7.5	16
			n_1	1950	4050	1500	3000	3525	1950	4050	1500	3600	1500
			I_{M230}	5.2	8.8	7.6	10.5		11.8				
			I_{M400}	2.6	4.5	3.8		5.7	5.9	10.2	4.5	7.5	6.6
			P_N	1.1	1.8	1.6	2.5	2.8	2.8	4.7	1.45	2.8	2.5
			J_M	4.12	4.12	7.42	7.42	7.42	10.72	10.72	8.22	8.22	14.32
12.283	1615	34.2	M_2 c n_2 Eck n_2 th										
13.36	1757	33.4	M_2 c n_2 Eck n_2 th										
16.122	1506	22.6	M_2 c n_2 Eck n_2 th										
16.122	1801	22.6	M_2 c n_2 Eck n_2 th										
17.536	1638	22.2	M_2 c n_2 Eck n_2 th										
17.536	1958	22.2	M_2 c n_2 Eck n_2 th										
19.541	2570	30.6	M_2 c n_2 Eck n_2 th										
22.022	2672	29.9	M_2 c n_2 Eck n_2 th										
25.649	2396	20.5	M_2 c n_2 Eck n_2 th										
25.649	2862	20.5	M_2 c n_2 Eck n_2 th										
29.228	2500	15.9	M_2 c n_2 Eck n_2 th										423 5.6 51 51
29.228	2914	15.9	M_2 c n_2 Eck n_2 th										
32.94	2818	15.6	M_2 c n_2 Eck n_2 th										476 5.6 46 46

$M \dots$ [Nm]
 $n \dots$ [min^{-1}]
 $J \dots$ [kgcm^2]

$P \dots$ [kW]
 $I \dots$ [A]
 $i \dots$ [-]
 $c \dots$ [-]

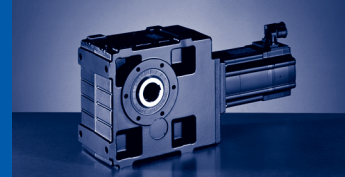

$M_{2GN} \leq 3080 \text{ Nm}$

14HC32	14LC15	14LC32	14PC14	14PC32	19FC14	19FC30	19JC14	19JC30	19PC14	19PC30	GKS09-3S			
...S00	...S00	...S00	...S00	...S00	...S00	...S00	...S00	...S00	...S00	...S00	M_1	J_G	M_{2GN}	i
14	23	17.2	30	21	27	21	40	29	51	32	n_1			
3225	1500	3225	1350	3225	1425	3000	1425	3000	1350	3000	I_{M230}			
											I_{M400}			
11.9	9.7	15	10.8	15.6	8.6	14	12.3	18.5	14.3	19	P_N			
4.7	3.6	5.8	4.2	7.1	4	6.6	6	9.1	7.2	10	J_M			
14.32	23.44	23.44	34.74	34.82	65.12	65.04	105.04	105.12	160.12	160.04	M_2			
					301	234	455	328	584	364	c	34.2	1615	12.283
					5.1	5.2	3.5	3.8	2.7	3.4	$n_{2 \text{ Eck}}$			
					116	244	116	244	110	244	$n_{2 \text{ th}}$			
					116	166	116	155	110	152				
					328	255	494	357	636	396	M_2			
					5.1	5.2	3.5	3.8	2.7	3.4	c	33.4	1757	13.36
					107	225	107	225	101	225	$n_{2 \text{ Eck}}$			
					107	153	107	143	101	139	$n_{2 \text{ th}}$			
204	340	254	448	313							M_2			
5.4	4.3	4.4	3.3	3.6							c	22.6	1506	16.122
200	93	200	84	200							$n_{2 \text{ Eck}}$			
145	93	139	84	133							$n_{2 \text{ th}}$			
					399	310	600	434	770	480	M_2			
					4.4	4.4	2.9	3.2	2.3	2.9	c	22.6	1801	16.122
					88	186	88	186	84	186	$n_{2 \text{ Eck}}$			
					88	137	88	130	84	127	$n_{2 \text{ th}}$			
222	370	276	488	340							M_2			
5.4	4.3	4.4	3.3	3.6							c	22.2	1638	17.536
184	86	184	77	184							$n_{2 \text{ Eck}}$			
133	86	128	77	122							$n_{2 \text{ th}}$			
					434	337	653	472	838	522	M_2			
					4.4	4.4	2.9	3.2	2.3	2.9	c	22.2	1958	17.536
					81	171	81	171	77	171	$n_{2 \text{ Eck}}$			
					81	126	81	119	77	117	$n_{2 \text{ th}}$			
					479	372	723	522	930	579	M_2			
					5.1	5.2	3.5	3.8	2.7	3.4	c	30.6	2570	19.541
					73	154	73	154	69	154	$n_{2 \text{ Eck}}$			
					73	105	73	97	69	95	$n_{2 \text{ th}}$			
					543	422	817	591	1050	654	M_2			
					4.7	4.8	3.2	3.5	2.5	3.2	c	29.9	2672	22.022
					65	136	65	136	61	136	$n_{2 \text{ Eck}}$			
					65	91	65	85	61	83	$n_{2 \text{ th}}$			
325	541	404	713	497							M_2			
5.4	4.3	4.4	3.3	3.6							c	20.5	2396	25.649
126	59	126	53	126							$n_{2 \text{ Eck}}$			
91	58	87	53	84							$n_{2 \text{ th}}$			
					635	493	955	690	1225	764	M_2			
					4.4	4.4	2.9	3.2	2.3	2.9	c	20.5	2862	25.649
					56	117	56	117	53	117	$n_{2 \text{ Eck}}$			
					56	86	56	81	53	80	$n_{2 \text{ th}}$			
372	619	462	815	569							M_2			
5	3.9	4.1	3	3.3							c	15.9	2500	29.228
110	51	110	46	110							$n_{2 \text{ Eck}}$			
86	51	82	46	79							$n_{2 \text{ th}}$			
					727	565	1092	789	1400	873	M_2			
					3.9	4	2.6	2.9	2.1	2.6	c	15.9	2914	29.228
					49	103	49	103	46	103	$n_{2 \text{ Eck}}$			
					49	76	49	76	46	75	$n_{2 \text{ th}}$			
420	698	521	919	641							M_2			
5	3.9	4.1	3	3.3							c	15.6	2818	32.94
98	46	98	41	98							$n_{2 \text{ Eck}}$			
76	46	73	41	70							$n_{2 \text{ th}}$			

$M \dots$ [Nm]
 $n \dots$ [min^{-1}]
 $J \dots$ [kgcm^2]

$P \dots$ [kW]
 $I \dots$ [A]
 $i [-]$
 $c [-]$

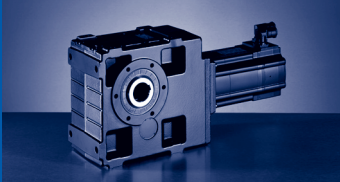

GKS [Nm]

GKS□□-□S (MCS)

$M_{2GN} \leq 3080 \text{ Nm}$

GKS09-3S				12DC20	12DC41	12HC15	12HC30	12HC35	12LC20	12LC41	14DC15	14DC36	14HC15
				...500	...500	...500	...500	...500	...500	...500	...500	...500	...500
i	M_{2GN}	J_G	M_1	5.5	4.3	10	8	7.5	13.5	11	9.2	7.5	16
			n_1	1950	4050	1500	3000	3525	1950	4050	1500	3600	1500
			I_{M230}	5.2	8.8	7.6	10.5		11.8				
			I_{M400}	2.6	4.5	3.8		5.7	5.9	10.2	4.5	7.5	6.6
			P_N	1.1	1.8	1.6	2.5	2.8	2.8	4.7	1.45	2.8	2.5
			J_M	4.12	4.12	7.42	7.42	7.42	10.72	10.72	8.22	8.22	14.32
32.94	2984	15.6	M_2 c $n_{2 \text{ Eck}}$ $n_{2 \text{ th}}$										
35.193	1686	12.2	M_2 c $n_{2 \text{ Eck}}$ $n_{2 \text{ th}}$			320 5 43 43	256 5 85 81	240 5.1 100 81	440 3.4 55 55	359 3.3 115 74			
35.193	2638	12.2	M_2 c $n_{2 \text{ Eck}}$ $n_{2 \text{ th}}$										513 4.9 43 43
35.193	3029	12.2	M_2 c $n_{2 \text{ Eck}}$ $n_{2 \text{ th}}$										
39.662	1900	12	M_2 c $n_{2 \text{ Eck}}$ $n_{2 \text{ th}}$			361 5 38 38	289 5 76 72	270 5.1 89 72	496 3.4 49 49	404 3.3 102 66			
39.662	2973	12	M_2 c $n_{2 \text{ Eck}}$ $n_{2 \text{ th}}$										578 4.9 38 38
39.662	3002	12	M_2 c $n_{2 \text{ Eck}}$ $n_{2 \text{ th}}$										
43.146	2776	9	M_2 c $n_{2 \text{ Eck}}$ $n_{2 \text{ th}}$										633 4.2 35 35
43.146	3024	9	M_2 c $n_{2 \text{ Eck}}$ $n_{2 \text{ th}}$										
48.625	3017	8.87	M_2 c $n_{2 \text{ Eck}}$ $n_{2 \text{ th}}$										715 4.1 31 31
58.456	1882	5.54	M_2 c $n_{2 \text{ Eck}}$ $n_{2 \text{ th}}$			541 3.4 26 26	431 3.8 51 51	404 3.9 60 60	738 2.5 33 33	601 2.5 69 56			
58.456	2940	5.54	M_2 c $n_{2 \text{ Eck}}$ $n_{2 \text{ th}}$								485 5.8 26 26	395 6 62 61	867 3.3 26 26
65.879	2121	5.47	M_2 c $n_{2 \text{ Eck}}$ $n_{2 \text{ th}}$			610 3.4 23 23	486 3.8 46 46	455 3.9 54 54	831 2.5 30 30	677 2.5 62 50			

$M \dots [\text{Nm}]$
 $n \dots [\text{min}^{-1}]$
 $J \dots [\text{kgcm}^2]$

$P \dots [\text{kW}]$
 $I \dots [\text{A}]$
 $i \dots [-]$
 $c \dots [-]$

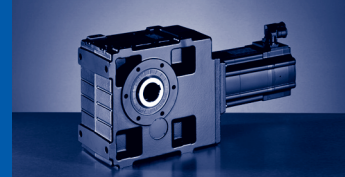

$M_{2GN} \leq 3080 \text{ Nm}$

14HC32	14LC15	14LC32	14PC14	14PC32	19FC14	19FC30	19JC14	19JC30	19PC14	19PC30	GKS09-3S			
...S00	...S00	...S00	...S00	...S00	...S00	...S00	...S00	...S00	...S00	...S00	M_1	J_G	M_{2GN}	i
14	23	17.2	30	21	27	21	40	29	51	32	n_1			
3225	1500	3225	1350	3225	1425	3000	1425	3000	1350	3000	I_{M230}			
											I_{M400}			
11.9	9.7	15	10.8	15.6	8.6	14	12.3	18.5	14.3	19	P_N			
4.7	3.6	5.8	4.2	7.1	4	6.6	6	9.1	7.2	10	J_M			
14.32	23.44	23.44	34.74	34.82	65.12	65.04	105.04	105.12	160.12	160.04	M_2			
					822	639	1233	892	1581	987	c	15.6	2984	32.94
					3.5	3.6	2.4	2.6	1.9	2.4	$n_{2 \text{ Eck}}$			
					43	91	43	91	41	91	$n_{2 \text{ th}}$			
					43	67	43	66	41	65	M_2			
											c	12.2	1686	35.193
											$n_{2 \text{ Eck}}$			
											$n_{2 \text{ th}}$			
451	749	560	986	688							M_2			
4.4	3.4	3.6	2.6	2.9							c	12.2	2638	35.193
92	43	92	38	92							$n_{2 \text{ Eck}}$			
79	43	75	38	72							$n_{2 \text{ th}}$			
					880	684	1319	954	1691	1056	M_2			
					3.4	3.4	2.3	2.5	1.8	2.3	c	12.2	3029	35.193
					41	85	41	85	38	85	$n_{2 \text{ Eck}}$			
					40	63	40	63	38	63	$n_{2 \text{ th}}$			
											M_2			
											c	12	1900	39.662
											$n_{2 \text{ Eck}}$			
											$n_{2 \text{ th}}$			
509	844	631	1111	775							M_2			
4.4	3.4	3.6	2.6	2.9							c	12	2973	39.662
81	38	81	34	81							$n_{2 \text{ Eck}}$			
70	38	67	34	64							$n_{2 \text{ th}}$			
					996	774	1491	1079	1910	1193	M_2			
					3	3	2	2.2	1.6	2	c	12	3002	39.662
					36	76	36	76	34	76	$n_{2 \text{ Eck}}$			
					36	56	36	56	34	56	$n_{2 \text{ th}}$			
554	923	687	1213	844							M_2			
4.3	3	3.5	2.3	2.8							c	9	2776	43.146
75	35	75	31	75							$n_{2 \text{ Eck}}$			
69	35	66	31	64							$n_{2 \text{ th}}$			
					1086	841	1625	1172	2080	1297	M_2			
					2.7	3.2	1.9	2.3	1.5	2.1	c	9	3024	43.146
					33	70	33	70	31	70	$n_{2 \text{ Eck}}$			
					33	51	33	51	31	51	$n_{2 \text{ th}}$			
625	1042	775	1368	952	1228	951	1835	1325	2349	1465	M_2			
4.1	2.8	3.3	2.2	2.7	2.4	2.8	1.6	2	1.3	1.8	c	8.87	3017	48.625
66	31	66	28	66	29	62	29	62	28	62	$n_{2 \text{ Eck}}$			
61	31	59	28	56	29	45	29	45	28	45	$n_{2 \text{ th}}$			
											M_2			
											c	5.54	1882	58.456
											$n_{2 \text{ Eck}}$			
											$n_{2 \text{ th}}$			
758	1260	938	1652	1151							M_2			
3.3	2.3	2.7	1.8	2.2							c	5.54	2940	58.456
55	26	55	23	55							$n_{2 \text{ Eck}}$			
55	26	55	23	55							$n_{2 \text{ th}}$			
											M_2			
											c	5.47	2121	65.879
											$n_{2 \text{ Eck}}$			
											$n_{2 \text{ th}}$			

$M \dots$ [Nm]
 $n \dots$ [min^{-1}]
 $J \dots$ [kgcm^2]

$P \dots$ [kW]
 $I \dots$ [A]
 i [-]
 c [-]

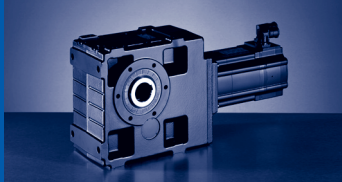

GKS [Nm]

GKS□□-□S (MCS)

$M_{2GN} \leq 3080 \text{ Nm}$

GKS09-3S				12DC20	12DC41	12HC15	12HC30	12HC35	12LC20	12LC41	14DC15	14DC36	14HC15
				...500	...500	...500	...500	...500	...500	...500	...500	...500	...500
i	M_{2GN}	J_G	M_1	5.5	4.3	10	8	7.5	13.5	11	9.2	7.5	16
			n_1	1950	4050	1500	3000	3525	1950	4050	1500	3600	1500
			I_{M230}	5.2	8.8	7.6	10.5		11.8				
			I_{M400}	2.6	4.5	3.8		5.7	5.9	10.2	4.5	7.5	6.6
			P_N	1.1	1.8	1.6	2.5	2.8	2.8	4.7	1.45	2.8	2.5
			J_M	4.12	4.12	7.42	7.42	7.42	10.72	10.72	8.22	8.22	14.32
65.879	3048	5.47	M_2								550	447	980
			c								5.3	5.5	3
			$n_{2 \text{ Eck}}$								23	55	23
			$n_{2 \text{ th}}$								23	55	23
70.982	1959	4.14	M_2	354	276	661	526	493	899	733			
			c	5.3	5.5	2.9	3.3	3.3	2.2	2.2			
			$n_{2 \text{ Eck}}$	28	57	21	42	50	28	57			
			$n_{2 \text{ th}}$	27	57	21	42	50	27	53			
70.982	3031	4.14	M_2								595	484	1058
			c								4.9	5.1	2.8
			$n_{2 \text{ Eck}}$								21	51	21
			$n_{2 \text{ th}}$								21	51	21
79.996	2207	4.1	M_2	399	311	745	593	556	1013	826			
			c	5.3	5.5	2.9	3.3	3.3	2.2	2.2			
			$n_{2 \text{ Eck}}$	24	51	19	38	44	24	51			
			$n_{2 \text{ th}}$	24	51	19	38	44	24	47			
79.996	3071	4.1	M_2								674	548	1196
			c								4.4	4.6	2.5
			$n_{2 \text{ Eck}}$								19	45	19
			$n_{2 \text{ th}}$								19	45	19
91.86	2032	2.63	M_2	464	362	860	686	643	1169	952			
			c	4.2	4.4	2.3	2.6	2.7	1.7	1.7			
			$n_{2 \text{ Eck}}$	21	44	16	33	38	21	44			
			$n_{2 \text{ th}}$	21	44	16	33	38	21	44			
91.86	3031	2.63	M_2								779	634	1379
			c								3.8	3.9	2.2
			$n_{2 \text{ Eck}}$								16	39	16
			$n_{2 \text{ th}}$								16	39	16
103.524	2290	2.61	M_2	522	408	970	773	725	1317	1073			
			c	4.2	4.4	2.3	2.6	2.7	1.7	1.7			
			$n_{2 \text{ Eck}}$	19	39	15	29	34	19	39			
			$n_{2 \text{ th}}$	19	39	14	29	34	19	39			
103.524	3080	2.61	M_2								882	718	1557
			c								3.4	3.5	2
			$n_{2 \text{ Eck}}$								15	35	15
			$n_{2 \text{ th}}$								14	35	14
111.484	2058	1.92	M_2	567	441	1048	834	782	1423	1158			
			c	3.5	4.1	1.9	2.4	2.5	1.4	1.6			
			$n_{2 \text{ Eck}}$	18	36	14	27	32	18	36			
			$n_{2 \text{ th}}$	17	36	13	27	32	17	36			
111.484	3031	1.92	M_2								953	773	1680
			c								3.1	3.6	1.8
			$n_{2 \text{ Eck}}$								14	32	14
			$n_{2 \text{ th}}$								13	32	13
125.641	2319	1.9	M_2	639	496	1182	940	881	1604	1304			
			c	3.5	4.1	1.9	2.4	2.5	1.4	1.6			
			$n_{2 \text{ Eck}}$	16	32	12	24	28	16	32			
			$n_{2 \text{ th}}$	16	32	12	24	28	16	32			
125.641	3080	1.9	M_2								1077	874	1897
			c								2.8	3.2	1.6
			$n_{2 \text{ Eck}}$								12	29	12
			$n_{2 \text{ th}}$								12	29	12

$M \dots$ [Nm]
 $n \dots$ [min^{-1}]
 $J \dots$ [kgcm^2]

$P \dots$ [kW]
 $I \dots$ [A]
 $i \dots$ [-]
 $c \dots$ [-]

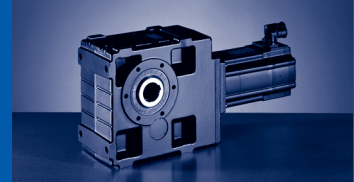

$M_{2GN} \leq 3080 \text{ Nm}$

14HC32	14LC15	14LC32	14PC14	14PC32	19FC14	19FC30	19JC14	19JC30	19PC14	19PC30	GKS09-3S			
...S00	...S00	...S00	...S00	...S00	...S00	...S00	...S00	...S00	...S00	...S00	M_1	J_G	M_{2GN}	i
14	23	17.2	30	21	27	21	40	29	51	32	n_1			
3225	1500	3225	1350	3225	1425	3000	1425	3000	1350	3000	I_{M230}			
											I_{M400}			
11.9	9.7	15	10.8	15.6	8.6	14	12.3	18.5	14.3	19	P_N			
4.7	3.6	5.8	4.2	7.1	4	6.6	6	9.1	7.2	10	J_M			
14.32	23.44	23.44	34.74	34.82	65.12	65.04	105.04	105.12	160.12	160.04	M_2			
857	1422	1059	1865	1300							c	5.47	3048	65.879
3.1	2.1	2.5	1.6	2							$n_{2 \text{ Eck}}$			
49	23	49	21	49							$n_{2 \text{ th}}$			
49	23	49	20	48							M_2			
											c	4.14	1959	70.982
											$n_{2 \text{ Eck}}$			
											$n_{2 \text{ th}}$			
926	1535	1144	2012	1403							M_2			
2.8	2	2.3	1.5	1.9							c	4.14	3031	70.982
45	21	45	19	45							$n_{2 \text{ Eck}}$			
45	21	45	19	45							$n_{2 \text{ th}}$			
											M_2			
											c	4.1	2207	79.996
											$n_{2 \text{ Eck}}$			
											$n_{2 \text{ th}}$			
1047	1734	1292	2271	1584							M_2			
2.5	1.8	2.1	1.4	1.7							c	4.1	3071	79.996
40	19	40	17	40							$n_{2 \text{ Eck}}$			
40	19	40	17	40							$n_{2 \text{ th}}$			
											M_2			
											c	2.63	2032	91.86
											$n_{2 \text{ Eck}}$			
											$n_{2 \text{ th}}$			
1206	1996	1488	2613	1824							M_2			
2.2	1.5	1.8	1.2	1.5							c	2.63	3031	91.86
35	16	35	15	35							$n_{2 \text{ Eck}}$			
35	16	35	15	35							$n_{2 \text{ th}}$			
											M_2			
											c	2.61	2290	103.524
											$n_{2 \text{ Eck}}$			
											$n_{2 \text{ th}}$			
1363	2253	1681	2949	2058							M_2			
2	1.4	1.6	1	1.3							c	2.61	3080	103.524
31	15	31	13	31							$n_{2 \text{ Eck}}$			
31	14	31	13	31							$n_{2 \text{ th}}$			
											M_2			
											c	1.92	2058	111.484
											$n_{2 \text{ Eck}}$			
											$n_{2 \text{ th}}$			
1467	2429	1809		2216							M_2			
2	1.2	1.6		1.3							c	1.92	3031	111.484
29	14	29		29							$n_{2 \text{ Eck}}$			
29	13	29		29							$n_{2 \text{ th}}$			
											M_2			
											c	1.9	2319	125.641
											$n_{2 \text{ Eck}}$			
											$n_{2 \text{ th}}$			
1657	2741	2043		2501							M_2			
1.8	1.1	1.5		1.2							c	1.9	3080	125.641
26	12	26		26							$n_{2 \text{ Eck}}$			
26	12	26		26							$n_{2 \text{ th}}$			

$M \dots$ [Nm]
 $n \dots$ [min^{-1}]
 $J \dots$ [kgcm^2]

$P \dots$ [kW]
 $I \dots$ [A]
 $i [-]$
 $c [-]$

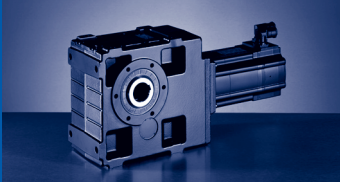

GKS [Nm]

GKS□□-□S (MCS)

$M_{2GN} \leq 3080 \text{ Nm}$

GKS09-3S				12DC20	12DC41	12HC15	12HC30	12HC35	12LC20	12LC41	14DC15	14DC36	14HC15
				...500	...500	...500	...500	...500	...500	...500	...500	...500	...500
i	M_{2GN}	J_G	M_1	5.5	4.3	10	8	7.5	13.5	11	9.2	7.5	16
			n_1	1950	4050	1500	3000	3525	1950	4050	1500	3600	1500
			I_{M230}	5.2	8.8	7.6	10.5		11.8				
			I_{M400}	2.6	4.5	3.8		5.7	5.9	10.2	4.5	7.5	6.6
			P_N	1.1	1.8	1.6	2.5	2.8	2.8	4.7	1.45	2.8	2.5
			J_M	4.12	4.12	7.42	7.42	7.42	10.72	10.72	8.22	8.22	14.32
140.921	2084	1.26	M_2	722	562	1331	1060	994	1804	1468			
			c	2.8	3.3	1.6	2	2	1.2	1.3			
			$n_{2 \text{ Eck}}$	14	29	11	21	25	14	29			
			$n_{2 \text{ th}}$	14	29	11	21	25	14	29			
158.816	2349	1.25	M_2	814	633	1500	1195	1120	2033	1654			
			c	2.8	3.3	1.6	2	2	1.2	1.3			
			$n_{2 \text{ Eck}}$	12	26	9	19	22	12	26			
			$n_{2 \text{ th}}$	12	26	9	19	22	12	26			
182	3031	2.25	M_2	929	722	1715	1366	1280	2326	1893	1575	1280	2763
			c	3.2	3.7	1.8	2.2	2.2	1.3	1.4	1.9	2.2	1.1
			$n_{2 \text{ Eck}}$	11	22	8	17	19	11	22	8	20	8
			$n_{2 \text{ th}}$	11	22	8	16	19	11	20	8	20	8
205.111	3080	2.24	M_2	1050	817	1936	1543	1446	2625	2136	1779	1446	
			c	2.9	3.3	1.6	2	2	1.2	1.3	1.7	2	
			$n_{2 \text{ Eck}}$	10	20	7	15	17	10	20	7	18	
			$n_{2 \text{ th}}$	10	20	7	15	17	10	20	7	18	
220.882	3031	1.66	M_2	1134	883	2088	1664	1560	2830	2303	1919	1560	
			c	2.6	3	1.5	1.8	1.8	1.1	1.2	1.6	1.8	
			$n_{2 \text{ Eck}}$	9	18	7	14	16	9	18	7	16	
			$n_{2 \text{ th}}$	9	18	7	14	16	9	18	7	16	
248.93	3080	1.65	M_2	1282	998	2357	1879	1761		2599	2166	1762	
			c	2.4	2.7	1.3	1.6	1.7		1.1	1.4	1.6	
			$n_{2 \text{ Eck}}$	8	16	6	12	14		16	6	15	
			$n_{2 \text{ th}}$	8	16	6	12	14		16	6	14	
279.205	3031	1.1	M_2	1442	1124	2648	2112	1980					
			c	2.1	2.4	1.1	1.4	1.4					
			$n_{2 \text{ Eck}}$	7	15	5	11	13					
			$n_{2 \text{ th}}$	7	15	5	11	13					
314.659	3080	1.1	M_2	1629	1269	2988	2384	2234					
			c	1.9	2.2	1	1.3	1.3					
			$n_{2 \text{ Eck}}$	6	13	5	10	11					
			$n_{2 \text{ th}}$	6	13	5	10	11					

M ... [Nm]
 n ... [min^{-1}]
 J ... [kgcm^2]

P ... [kW]
 I ... [A]
 i [-]
 c [-]

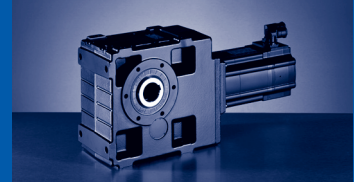

$M_{2GN} \leq 3080 \text{ Nm}$

14HC32	14LC15	14LC32	14PC14	14PC32	19FC14	19FC30	19JC14	19JC30	19PC14	19PC30	GKS09-3S			
...S00	...S00	...S00	...S00	...S00	...S00	...S00	...S00	...S00	...S00	...S00	M_1	J_G	M_{2GN}	i
14	23	17.2	30	21	27	21	40	29	51	32	n_1			
3225	1500	3225	1350	3225	1425	3000	1425	3000	1350	3000	I_{M230}			
											I_{M400}			
11.9	9.7	15	10.8	15.6	8.6	14	12.3	18.5	14.3	19	P_N			
4.7	3.6	5.8	4.2	7.1	4	6.6	6	9.1	7.2	10	J_M			
14.32	23.44	23.44	34.74	34.82	65.12	65.04	105.04	105.12	160.12	160.04	M_2			
											c			
											n_2 Eck	1.26	2084	140.921
											n_2 th			
											M_2			
											c			
											n_2 Eck	1.25	2349	158.816
											n_2 th			
2415											M_2			
1.2											c			
18											n_2 Eck	2.25	3031	182
18											n_2 th			
2725											M_2			
1.1											c			
16											n_2 Eck	2.24	3080	205.111
16											n_2 th			
2937											M_2			
1											c			
15											n_2 Eck	1.66	3031	220.882
15											n_2 th			
											M_2			
											c			
											n_2 Eck	1.65	3080	248.93
											n_2 th			
											M_2			
											c			
											n_2 Eck	1.1	3031	279.205
											n_2 th			
											M_2			
											c			
											n_2 Eck	1.1	3080	314.659
											n_2 th			

M ... [Nm]
n ... [min⁻¹]
J ... [kgcm²]

P ... [kW]
I ... [A]
i [-]
c [-]

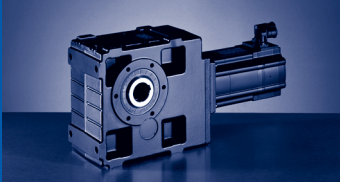

GKS [Nm]

GKS□□-□S (MCS)

$M_{2GN} \leq 3080 \text{ Nm}$

GKS09-4S				06CC41	06FC41	06IC41	09DC41	09FC38	09HC41	09LC41	12DC20	12DC41	12HC15	12HC30
				...S00	...S00	...S00	...S00	...S00	...S00	...S00	...S00	...S00	...S00	...S00
i	M_{2GN}	J_G	M_1	0.6	1.2	1.5	2.3	3.1	3.8	4.5	5.5	4.3	10	8
			n_1	4050	4050	4050	4050	3750	4050	4050	1950	4050	1500	3000
			I_{M230}	2.6	2.9	3.2	4.6	5	6.8	8.4	5.2	8.8	7.6	10.5
			I_{M400}	1.3	1.5	1.6	2.3	2.5	3.4	4.2	2.6	4.5	3.8	
			P_N	0.25	0.51	0.64	1	1.2	1.6	1.9	1.1	1.8	1.6	2.5
			J_M	0.17	0.25	0.33	1.13	1.53	1.93	2.83	4.12	4.12	7.42	7.42
100.551	2358	2.48	M_2 c						340	406				
			n_2 Eck						5.4	4.6				
			n_2 th						40	40				
			n_2 th						40	40				
100.551	3029	2.48	M_2 c								489		916	730
			n_2 Eck								5.9		3.2	3.6
			n_2 th								19		15	30
			n_2 th								19		15	30
113.32	2658	2.46	M_2 c						381	455				
			n_2 Eck						6	5.1				
			n_2 th						36	36				
			n_2 th						36	36				
113.32	3002	2.46	M_2 c								556	431	1037	823
			n_2 Eck								5.2	6	2.8	3.6
			n_2 th								17	36	13	27
			n_2 th								17	36	13	26
123.275	2891	2.11	M_2 c						414	495				
			n_2 Eck						6	5.1				
			n_2 th						33	33				
			n_2 th						33	33				
123.275	3024	2.11	M_2 c								607	471	1131	898
			n_2 Eck								4.8	5.5	2.6	3.3
			n_2 th								16	33	12	24
			n_2 th								16	33	12	24
138.929	3017	2.09	M_2 c						469	561	689	535	1279	1017
			n_2 Eck						5.5	4.7	4.2	4.9	2.3	2.9
			n_2 th						29	29	14	29	11	22
			n_2 th						29	29	14	29	11	22
151.012	3024	1.52	M_2 c						512	612	751	583	1393	1108
			n_2 Eck						5.1	4.3	3.9	4.5	2.2	2.7
			n_2 th						27	27	13	27	10	20
			n_2 th						27	27	13	27	10	20
170.188	3017	1.51	M_2 c					468	581	694	851	661	1574	1253
			n_2 Eck					5.7	4.5	3.8	3.5	4	1.9	2.4
			n_2 th					22	24	24	12	24	9	18
			n_2 th					22	24	24	11	24	9	18
204.596	3031	1.24	M_2 c					568	704	839	1029	801	1898	1512
			n_2 Eck					4.8	3.8	3.2	2.9	3.3	1.6	2
			n_2 th					18	20	20	10	20	7	15
			n_2 th					18	20	20	10	20	7	15
230.577	3048	1.24	M_2 c				471	644	797	950	1164	906	2143	1708
			n_2 Eck				5.6	4.2	3.4	2.9	2.6	3	1.4	1.8
			n_2 th				18	16	18	18	9	18	7	13
			n_2 th				18	16	18	18	8	18	7	13
248.439	3031	1.13	M_2 c				510	697	862	1026	1257	979	2312	1843
			n_2 Eck				5.1	3.9	3.1	2.6	2.4	2.8	1.3	1.6
			n_2 th				16	15	16	16	8	16	6	12
			n_2 th				16	15	16	16	8	16	6	12
279.986	3071	1.13	M_2 c				578	789	974	1159	1420	1106	2609	2081
			n_2 Eck				4.6	3.5	2.8	2.4	2.1	2.5	1.2	1.5
			n_2 th				15	13	15	15	7	15	5	11
			n_2 th				14	13	14	14	7	14	5	11

M ... [Nm]
n ... [min⁻¹]
J ... [kgcm²]

P ... [kW]
I ... [A]
i [-]
c [-]

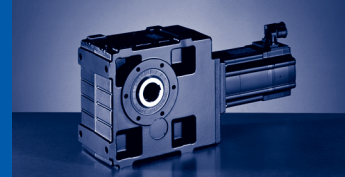

$M_{2GN} \leq 3080 \text{ Nm}$

12HC35	12LC20	12LC41	14DC15	14DC36	14HC15	14HC32	14LC15	14LC32	14PC14	14PC32	GKS09-4S			
...S00	...S00	...S00	...S00	...S00	...S00	...S00	...S00	...S00	...S00	...S00	M_1	J_G	M_{2GN}	i
7.5	13.5	11	9.2	7.5	16	14	23	17.2	30	21	M_1			
3525	1950	4050	1500	3600	1500	3225	1500	3225	1350	3225	n_1			
	11.8										I_{M230}			
5.7	5.9	10.2	4.5	7.5	6.6	11.9	9.7	15	10.8	15.6	I_{M400}			
2.8	2.8	4.7	1.45	2.8	2.5	4.7	3.6	5.8	4.2	7.1	P_N			
7.42	10.72	10.72	8.22	8.22	14.32	14.32	23.44	23.44	34.74	34.82	J_M			
											M_2			
											c	2.48	2358	100.551
											n_2			
											Eck			
											n_2			
											th			
684	1249	1017	841	684	1486	1300	2150	1604	2814	1964	M_2			
3.7	2.4	2.4	3.5	3.7	2	2	1.4	1.7	1.1	1.4	c	2.48	3029	100.551
35	19	40	15	36	15	32	15	32	13	32	n_2			
35	19	40	15	36	15	32	15	32	13	32	Eck			
											n_2			
											th			
											M_2			
											c	2.46	2658	113.32
											n_2			
											Eck			
											n_2			
											th			
772	1412	1147	952	772	1679	1466	2428	1808		2214	M_2			
3.6	2.1	2.3	3.1	3.6	1.8	2	1.2	1.6		1.3	c	2.46	3002	113.32
31	17	36	13	32	13	29	13	29		29	n_2			
31	17	36	13	32	13	28	13	28		28	Eck			
											n_2			
											th			
											M_2			
											c	2.11	2891	123.275
											n_2			
											Eck			
											n_2			
											th			
842	1538	1250	1038	842	1829	1597	2643	1969		2411	M_2			
3.3	2	2.2	2.9	3.3	1.6	1.8	1.1	1.5		1.2	c	2.11	3024	123.275
29	16	33	12	29	12	26	12	26		26	n_2			
29	16	33	12	29	12	26	12	26		26	Eck			
											n_2			
											th			
953	1738	1413	1174	953	2065	1804	2983	2224		2722	M_2			
2.9	1.7	1.9	2.5	2.9	1.5	1.6	1	1.3		1.1	c	2.09	3017	138.929
25	14	29	11	26	11	23	11	23		23	n_2			
25	14	29	11	26	11	23	11	23		23	Eck			
											n_2			
											th			
1038	1892	1538	1279	1038	2248	1964		2420			M_2			
2.7	1.6	1.8	2.3	2.7	1.3	1.5		1.2			c	1.52	3024	151.012
23	13	27	10	24	10	21		21			n_2			
23	13	27	10	24	10	21		21			Eck			
											n_2			
											th			
1174	2136	1737	1445	1174	2537	2217		2731			M_2			
2.4	1.4	1.6	2.1	2.4	1.2	1.3		1.1			c	1.51	3017	170.188
21	12	24	9	21	9	19		19			n_2			
21	11	24	9	21	9	19		19			Eck			
											n_2			
											th			
1417	2574	2095	1744	1418		2671					M_2			
2	1.2	1.3	1.7	2		1.1					c	1.24	3031	204.596
17	10	20	7	18		16					n_2			
17	10	20	7	18		16					Eck			
											n_2			
											th			
1601	2905	2364	1969	1601							M_2			
1.8	1.1	1.2	1.5	1.8							c	1.24	3048	230.577
15	9	18	7	16							n_2			
15	8	18	7	16							Eck			
											n_2			
											th			
1728		2550	2125	1728							M_2			
1.7		1.1	1.4	1.6							c	1.13	3031	248.439
14		16	6	15							n_2			
14		16	6	14							Eck			
											n_2			
											th			
1951			2398	1951							M_2			
1.5			1.3	1.5							c	1.13	3071	279.986
13			5	13							n_2			
13			5	13							Eck			
											n_2			
											th			

M ... [Nm]
n ... [min⁻¹]
J ... [kgcm²]

P ... [kW]
I ... [A]
i [-]
c [-]

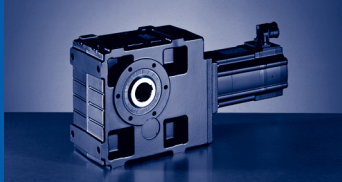

GKS [Nm]

GKS□□-□S (MCS)

$M_{2GN} \leq 3080 \text{ Nm}$

GKS09-4S				06CC41	06FC41	06IC41	09DC41	09FC38	09HC41	09LC41	12DC20	12DC41	12HC15	12HC30	
				...500	...500	...500	...500	...500	...500	...500	...500	...500	...500	...500	...500
i	M_{2GN}	J_G	M_1	0.6	1.2	1.5	2.3	3.1	3.8	4.5	5.5	4.3	10	8	
			n_1	4050	4050	4050	4050	3750	4050	4050	1950	4050	1500	3000	
			I_{M230}	2.6	2.9	3.2	4.6	5	6.8	8.4	5.2	8.8	7.6	10.5	
			I_{M400}	1.3	1.5	1.6	2.3	2.5	3.4	4.2	2.6	4.5	3.8		
			P_N	0.25	0.51	0.64	1	1.2	1.6	1.9	1.1	1.8	1.6	2.5	
			J_M	0.17	0.25	0.33	1.13	1.53	1.93	2.83	4.12	4.12	7.42	7.42	
323.365	3031	0.71	M_2				673	916	1130	1344	1646	1283	3019	2409	
			c				4	3	2.4	2	1.8	2.1	1	1.3	
			$n_{2 \text{ Eck}}$				13	12	13	13	13	6	13	5	9
			$n_{2 \text{ th}}$				13	12	13	13	13	6	13	5	9
364.427	3071	0.71	M_2			486	761	1036	1277	1518	1859	1449		2718	
			c			5.4	3.6	2.7	2.2	1.8	1.6	1.9		1.1	
			$n_{2 \text{ Eck}}$			11	11	10	11	11	5	11		8	
			$n_{2 \text{ th}}$			11	11	10	11	11	5	11		8	
402.234	3031	0.51	M_2			540	844	1147	1413	1679	2055	1603		3004	
			c			4.9	3.2	2.4	1.9	1.6	1.5	1.7		1	
			$n_{2 \text{ Eck}}$			10	10	9	10	10	5	10		8	
			$n_{2 \text{ th}}$			10	10	9	10	10	5	10		7	
453.311	3071	0.51	M_2		484	612	954	1296	1596	1895	2320	1810			
			c		5.5	4.4	2.9	2.2	1.7	1.5	1.3	1.5			
			$n_{2 \text{ Eck}}$		9	9	9	8	9	9	4	9			
			$n_{2 \text{ th}}$		9	9	9	8	9	9	4	9			
520.538	3031	0.47	M_2		560	707	1100	1493	1837	2181	2669	2083			
			c		4.7	3.8	2.5	1.9	1.5	1.3	1.1	1.3			
			$n_{2 \text{ Eck}}$		8	8	8	7	8	8	4	8			
			$n_{2 \text{ th}}$		8	8	8	7	8	8	4	8			
586.638	3080	0.47	M_2		634	801	1243	1686	2074	2461	3012	2351			
			c		4.2	3.4	2.2	1.7	1.3	1.1	1	1.2			
			$n_{2 \text{ Eck}}$		7	7	7	6	7	7	3	7			
			$n_{2 \text{ th}}$		7	7	7	6	7	7	3	7			
631.744	3031	0.44	M_2		686	865	1342	1818	2236	2653		2534			
			c		3.9	3.1	2	1.5	1.2	1		1.1			
			$n_{2 \text{ Eck}}$		6	6	6	6	6	6		6			
			$n_{2 \text{ th}}$		6	6	6	6	6	6		6			
711.965	3080	0.44	M_2		776	978	1516	2052	2523						
			c		3.5	2.8	1.8	1.4	1.1						
			$n_{2 \text{ Eck}}$		6	6	6	5	6						
			$n_{2 \text{ th}}$		6	6	6	5	6						
817.551	3031	0.28	M_2	434	896	1128	1745	2362							
			c	6	3	2.4	1.6	1.2							
			$n_{2 \text{ Eck}}$	5	5	5	5	5							
			$n_{2 \text{ th}}$	5	5	5	5	5							
921.367	3080	0.28	M_2	492	1014	1274	1970	2665							
			c	5.4	2.7	2.2	1.4	1.1							
			$n_{2 \text{ Eck}}$	4	4	4	4	4							
			$n_{2 \text{ th}}$	4	4	4	4	4							
992.209	3031	0.2	M_2	532	1094	1375	2124								
			c	4.9	2.5	2	1.3								
			$n_{2 \text{ Eck}}$	4	4	4	4								
			$n_{2 \text{ th}}$	4	4	4	4								
1118.204	3080	0.2	M_2	603	1236	1553	2397								
			c	4.5	2.2	1.8	1.2								
			$n_{2 \text{ Eck}}$	4	4	4	4								
			$n_{2 \text{ th}}$	4	4	4	4								
1254.197	3031	0.13	M_2	681	1391	1746									
			c	3.9	2	1.6									
			$n_{2 \text{ Eck}}$	3	3	3									
			$n_{2 \text{ th}}$	3	3	3									

$M \dots$ [Nm]
 $n \dots$ [min^{-1}]
 $J \dots$ [kgcm^2]

$P \dots$ [kW]
 $I \dots$ [A]
 $i \dots$ [-]
 $c \dots$ [-]

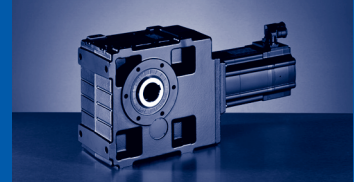

$M_{2GN} \leq 3080 \text{ Nm}$

12HC35	12LC20	12LC41	14DC15	14DC36	14HC15	14HC32	14LC15	14LC32	14PC14	14PC32	GKS09-4S			
...S00	...S00	...S00	...S00	...S00	...S00	...S00	...S00	...S00	...S00	...S00	M_1	J_G	M_{2GN}	i
7.5	13.5	11	9.2	7.5	16	14	23	17.2	30	21	n_1			
3525	1950	4050	1500	3600	1500	3225	1500	3225	1350	3225	I_{M230}			
	11.8										I_{M400}			
5.7	5.9	10.2	4.5	7.5	6.6	11.9	9.7	15	10.8	15.6	P_N			
2.8	2.8	4.7	1.45	2.8	2.5	4.7	3.6	5.8	4.2	7.1	J_M			
7.42	10.72	10.72	8.22	8.22	14.32	14.32	23.44	23.44	34.74	34.82	M_2			
2258											c	0.71	3031	323.365
1.3											$n_{2 \text{ Eck}}$			
11											$n_{2 \text{ th}}$			
11											M_2			
2548											c	0.71	3071	364.427
1.1											$n_{2 \text{ Eck}}$			
10											$n_{2 \text{ th}}$			
10											M_2			
2816											c	0.51	3031	402.234
1											$n_{2 \text{ Eck}}$			
9											$n_{2 \text{ th}}$			
9											M_2			
											c	0.51	3071	453.311
											$n_{2 \text{ Eck}}$			
											$n_{2 \text{ th}}$			
											M_2			
											c	0.47	3031	520.538
											$n_{2 \text{ Eck}}$			
											$n_{2 \text{ th}}$			
											M_2			
											c	0.47	3080	586.638
											$n_{2 \text{ Eck}}$			
											$n_{2 \text{ th}}$			
											M_2			
											c	0.44	3031	631.744
											$n_{2 \text{ Eck}}$			
											$n_{2 \text{ th}}$			
											M_2			
											c	0.44	3080	711.965
											$n_{2 \text{ Eck}}$			
											$n_{2 \text{ th}}$			
											M_2			
											c	0.28	3031	817.551
											$n_{2 \text{ Eck}}$			
											$n_{2 \text{ th}}$			
											M_2			
											c	0.28	3080	921.367
											$n_{2 \text{ Eck}}$			
											$n_{2 \text{ th}}$			
											M_2			
											c	0.2	3031	992.209
											$n_{2 \text{ Eck}}$			
											$n_{2 \text{ th}}$			
											M_2			
											c	0.2	3080	1118.204
											$n_{2 \text{ Eck}}$			
											$n_{2 \text{ th}}$			
											M_2			
											c	0.13	3031	1254.197
											$n_{2 \text{ Eck}}$			
											$n_{2 \text{ th}}$			

$M \dots$ [Nm]
 $n \dots$ [min^{-1}]
 $J \dots$ [kgcm^2]

$P \dots$ [kW]
 $I \dots$ [A]
 i [-]
 c [-]

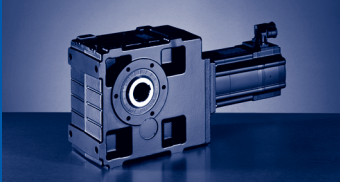

GKS [Nm]

GKS□□-□S (MCS)

$M_{2GN} \leq 3080 \text{ Nm}$

GKS09-4S				06CC41	06FC41	06IC41	09DC41	09FC38	09HC41	09LC41	12DC20	12DC41	12HC15	12HC30
				...S00	...S00	...S00	...S00	...S00	...S00	...S00	...S00	...S00	...S00	...S00
i	M_{2GN}	J_G	M_1	0.6	1.2	1.5	2.3	3.1	3.8	4.5	5.5	4.3	10	8
			n_1	4050	4050	4050	4050	3750	4050	4050	1950	4050	1500	3000
			I_{M230}	2.6	2.9	3.2	4.6	5	6.8	8.4	5.2	8.8	7.6	10.5
			I_{M400}	1.3	1.5	1.6	2.3	2.5	3.4	4.2	2.6	4.5	3.8	
			P_N	0.25	0.51	0.64	1	1.2	1.6	1.9	1.1	1.8	1.6	2.5
			J_M	0.17	0.25	0.33	1.13	1.53	1.93	2.83	4.12	4.12	7.42	7.42
1413.461	3080	0.13	M_2	770	1571	1971								
			c	3.5	1.8	1.4								
			$n_{2 \text{ Eck}}$	3	3	3								
			$n_{2 \text{ th}}$	3	3	3								

$M \dots [\text{Nm}]$
 $n \dots [\text{min}^{-1}]$
 $J \dots [\text{kgcm}^2]$

$P \dots [\text{kW}]$
 $I \dots [\text{A}]$
 $i [-]$
 $c [-]$

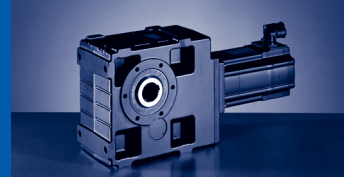

$M_{2GN} \leq 3080 \text{ Nm}$

12HC35	12LC20	12LC41	14DC15	14DC36	14HC15	14HC32	14LC15	14LC32	14PC14	14PC32	GKS09-4S			
...S00	...S00	...S00	...S00	...S00	...S00	...S00	...S00	...S00	...S00	...S00	M_1	J_G	M_{2GN}	i
7.5	13.5	11	9.2	7.5	16	14	23	17.2	30	21	n_1			
3525	1950	4050	1500	3600	1500	3225	1500	3225	1350	3225	I_{M230}			
	11.8										I_{M400}			
5.7	5.9	10.2	4.5	7.5	6.6	11.9	9.7	15	10.8	15.6	P_N			
2.8	2.8	4.7	1.45	2.8	2.5	4.7	3.6	5.8	4.2	7.1	J_M			
7.42	10.72	10.72	8.22	8.22	14.32	14.32	23.44	23.44	34.74	34.82	M_2			
											c	0.13	3080	1413.461
											$n_{2 \text{ Eck}}$			
											$n_{2 \text{ th}}$			

M ... [Nm]
n ... [min^{-1}]
J ... [kgcm^2]

P ... [kW]
I ... [A]
i [-]
c [-]

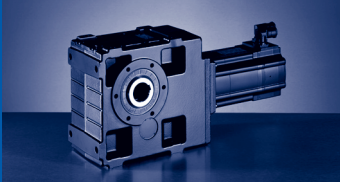

GKS [Nm]

GKS□□-□S (MCS)

$M_{2GN} \leq 6032 \text{ Nm}$

GKS11-3S				14DC15	14DC36	14HC15	14HC32	14LC15	14LC32	14PC14
				...500	...500	...500	...500	...500	...500	...500
i	M_{2GN}	J_G	M_1							
			n_1	9.2	7.5	16	14	23	17.2	30
			I_{M400}	1.500	3600	1500	3225	1500	3225	1350
			P_N	4.5	7.5	6.6	11.9	9.7	15	10.8
			J_M	1.45	2.8	2.5	4.7	3.6	5.8	4.2
			M_2	8.22	8.22	14.32	14.32	23.44	23.44	34.74
12.094	2592	104	c							
			$n_{2 \text{ Eck}}$							
			$n_{2 \text{ th}}$							
13.154	2819	101	c							
			$n_{2 \text{ Eck}}$							
			$n_{2 \text{ th}}$							
15.874	2868	68	c							
			$n_{2 \text{ Eck}}$							
			$n_{2 \text{ th}}$							
17.265	3119	66.5	c							
			$n_{2 \text{ Eck}}$							
			$n_{2 \text{ th}}$							
19.515	4182	90.3	c							
			$n_{2 \text{ Eck}}$							
			$n_{2 \text{ th}}$							
21.989	4712	90.4	c							
			$n_{2 \text{ Eck}}$							
			$n_{2 \text{ th}}$							
25.615	4628	61.2	c							
			$n_{2 \text{ Eck}}$							
			$n_{2 \text{ th}}$							
28.021	4791	52.2	c							
			$n_{2 \text{ Eck}}$							
			$n_{2 \text{ th}}$							
31.573	5398	51.3	c							
			$n_{2 \text{ Eck}}$							
			$n_{2 \text{ th}}$							
35.741	3314	36.8	c				453	754	563	994
			$n_{2 \text{ Eck}}$				5.4	4.2	4.4	3.3
			$n_{2 \text{ th}}$				90	42	90	38
			$n_{2 \text{ th}}$				65	42	63	38
35.741	5147	36.8	c							
			$n_{2 \text{ Eck}}$							
			$n_{2 \text{ th}}$							
40.272	3734	36.2	c				511	850	634	1120
			$n_{2 \text{ Eck}}$				5.4	4.2	4.4	3.3
			$n_{2 \text{ th}}$				80	37	80	34
			$n_{2 \text{ th}}$				58	37	56	34
40.272	5799	36.2	c							
			$n_{2 \text{ Eck}}$							
			$n_{2 \text{ th}}$							

$M \dots$ [Nm]
 $n \dots$ [min^{-1}]
 $J \dots$ [kgcm^2]

$P \dots$ [kW]
 $I \dots$ [A]
 $i \dots$ [-]
 $c \dots$ [-]

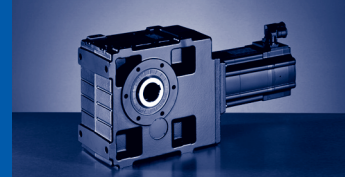

$M_{2GN} \leq 6032 \text{ Nm}$

14PC32	19FC14	19FC30	19JC14	19JC30	19PC14	19PC30	GKS11-3S			
...500	...500	...500	...500	...500	...500	...500				
21	27	21	40	29	51	32	M_1	J_G	M_{2GN}	i
3225	1425	3000	1425	3000	1350	3000	n_1			
15.6	8.6	14	12.3	18.5	14.3	19	I_{M400}			
7.1	4	6.6	6	9.1	7.2	10	P_N			
34.82	65.12	65.04	105.04	105.12	160.12	160.04	J_M			
			437		565	350	M_2			
			5.6		4.4	5.6	c			
			118		112	248	$n_{2 \text{ Eck}}$	104	2592	12.094
			118		112	144	$n_{2 \text{ th}}$			
			475		614	380	M_2			
			5.6		4.4	5.6	c			
			108		103	228	$n_{2 \text{ Eck}}$	101	2819	13.154
			108		103	132	$n_{2 \text{ th}}$			
			579	418	747	464	M_2			
			4.8	5.2	3.7	4.7	c			
			90	189	85	189	$n_{2 \text{ Eck}}$	68	2868	15.874
			90	125	85	123	$n_{2 \text{ th}}$			
			630	455	812	504	M_2			
			4.8	5.2	3.7	4.7	c			
			83	174	78	174	$n_{2 \text{ Eck}}$	66.5	3119	17.265
			83	115	78	113	$n_{2 \text{ th}}$			
			705		911	564	M_2			
			5.6		4.4	5.6	c			
			73		69	154	$n_{2 \text{ Eck}}$	90.3	4182	19.515
			73		69	89	$n_{2 \text{ th}}$			
			795		1027	636	M_2			
			5.6		4.4	5.6	c			
			65		61	136	$n_{2 \text{ Eck}}$	90.4	4712	21.989
			65		61	79	$n_{2 \text{ th}}$			
			935	674	1205	748	M_2			
			4.8	5.2	3.7	4.7	c			
			56	117	53	117	$n_{2 \text{ Eck}}$	61.2	4628	25.615
			56	78	53	76	$n_{2 \text{ th}}$			
			1025	740	1321	821	M_2			
			4.5	4.9	3.5	4.5	c			
			51	107	48	107	$n_{2 \text{ Eck}}$	52.2	4791	28.021
			51	72	48	71	$n_{2 \text{ th}}$			
			1155	834	1489	925	M_2			
			4.5	4.9	3.5	4.5	c			
			45	95	43	95	$n_{2 \text{ Eck}}$	51.3	5398	31.573
			45	64	43	63	$n_{2 \text{ th}}$			
693							M_2			
3.6							c			
90							$n_{2 \text{ Eck}}$	36.8	3314	35.741
60							$n_{2 \text{ th}}$			
	872	677	1318	952	1695	1055	M_2			
	5.6	5.7	3.8	4.2	3	3.8	c			
	40	84	40	84	38	84	$n_{2 \text{ Eck}}$	36.8	5147	35.741
	40	62	40	62	38	61	$n_{2 \text{ th}}$			
781							M_2			
3.6							c			
80							$n_{2 \text{ Eck}}$	36.2	3734	40.272
53							$n_{2 \text{ th}}$			
	983	763	1485	1073	1910	1189	M_2			
	5.6	5.7	3.8	4.2	3	3.8	c			
	35	75	35	75	34	75	$n_{2 \text{ Eck}}$	36.2	5799	40.272
	35	55	35	55	34	54	$n_{2 \text{ th}}$			

M ... [Nm]
n ... [min⁻¹]
J ... [kgcm²]

P ... [kW]
I ... [A]
i [-]
c [-]

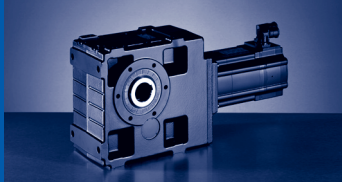

GKS [Nm]

GKS□□-□S (MCS)

$M_{2GN} \leq 6032 \text{ Nm}$

GKS11-3S				14DC15	14DC36	14HC15	14HC32	14LC15	14LC32	14PC14
				...500	...500	...500	...500	...500	...500	...500
i	M_{2GN}	J_G	M_1							
			n_1	9.2	7.5	16	14	23	17.2	30
			I_{M400}	1500	3600	1500	3225	1500	3225	1350
			P_N	4.5	7.5	6.6	11.9	9.7	15	10.8
			J_M	1.45	2.8	2.5	4.7	3.6	5.8	4.2
			M_2	8.22	8.22	14.32	14.32	23.44	23.44	34.74
43.783	5419	27.9	c							
			$n_{2 \text{ Eck}}$							
			$n_{2 \text{ th}}$							
49.333	5923	27.5	c							
			$n_{2 \text{ Eck}}$							
			$n_{2 \text{ th}}$							
57.683	3683	17.7	c			847	741	1235	918	1622
			$n_{2 \text{ Eck}}$			4.2	4.2	2.9	3.4	2.2
			$n_{2 \text{ th}}$			26	56	26	56	23
			$n_{2 \text{ th}}$			26	52	26	50	23
57.683	5726	17.7	c							
			$n_{2 \text{ Eck}}$							
			$n_{2 \text{ th}}$							
64.995	4149	17.5	c			954	835	1391	1035	1828
			$n_{2 \text{ Eck}}$			4.2	4.2	2.9	3.4	2.2
			$n_{2 \text{ th}}$			23	50	23	50	21
			$n_{2 \text{ th}}$			23	46	23	44	21
64.995	5992	17.5	c							
			$n_{2 \text{ Eck}}$							
			$n_{2 \text{ th}}$							
70.887	3776	13	c			1049	918	1525	1135	2002
			$n_{2 \text{ Eck}}$			3.5	3.5	2.4	2.9	1.9
			$n_{2 \text{ th}}$			21	46	21	46	19
			$n_{2 \text{ th}}$			21	45	21	45	19
70.887	5867	13	c							
			$n_{2 \text{ Eck}}$							
			$n_{2 \text{ th}}$							
79.873	4255	12.9	c			1182	1034	1719	1279	2255
			$n_{2 \text{ Eck}}$			3.5	3.5	2.4	2.9	1.9
			$n_{2 \text{ th}}$			19	40	19	40	17
			$n_{2 \text{ th}}$			19	40	19	40	17
79.873	6032	12.9	c							
			$n_{2 \text{ Eck}}$							
			$n_{2 \text{ th}}$							
91.737	3915	8.3	c	769	625	1368	1196	1984	1478	2600
			$n_{2 \text{ Eck}}$	4.9	5.1	2.8	2.8	2	2.3	1.5
			$n_{2 \text{ th}}$	16	39	16	35	16	35	15
			$n_{2 \text{ th}}$	16	39	16	35	16	35	15
103.365	4411	8.21	c	866	705	1541	1348	2236	1666	2930
			$n_{2 \text{ Eck}}$	4.9	5.1	2.8	2.8	2	2.3	1.5
			$n_{2 \text{ th}}$	15	35	15	31	15	31	13
			$n_{2 \text{ th}}$	15	35	15	31	15	31	13
111.335	3963	6.05	c	941	762	1668	1455	2416	1797	3164
			$n_{2 \text{ Eck}}$	4.1	4.7	2.3	2.6	1.6	2.1	1.3
			$n_{2 \text{ th}}$	14	32	14	29	14	29	12
			$n_{2 \text{ th}}$	13	32	13	29	13	29	12

$M \dots$ [Nm]
 $n \dots$ [min^{-1}]
 $J \dots$ [kgcm^2]

$P \dots$ [kW]
 $I \dots$ [A]
 i [-]
 c [-]

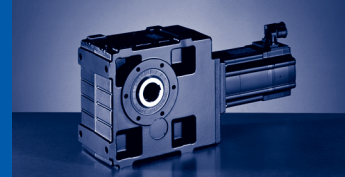

$M_{2GN} \leq 6032 \text{ Nm}$

14PC32	19FC14	19FC30	19JC14	19JC30	19PC14	19PC30	GKS11-3S			
...500	...500	...500	...500	...500	...500	...500				
21	27	21	40	29	51	32	M_1	J_G	M_{2GN}	i
3225	1425	3000	1425	3000	1350	3000	n_1			
15.6	8.6	14	12.3	18.5	14.3	19	I_{M400}			
7.1	4	6.6	6	9.1	7.2	10	P_N			
34.82	65.12	65.04	105.04	105.12	160.12	160.04	J_M			
	1078	831	1624	1167	2086	1293	M_2			
	4.8	5.6	3.3	4.1	2.6	3.7	c	27.9	5419	43.783
	33	69	33	69	31	69	$n_{2 \text{ Eck}}$			
	33	50	33	50	31	50	$n_{2 \text{ th}}$			
	1216	938	1832	1317	2353	1459	M_2			
	4.7	5.4	3.2	3.9	2.5	3.6	c	27.5	5923	49.333
	29	61	29	61	27	61	$n_{2 \text{ Eck}}$			
	29	45	29	45	27	45	$n_{2 \text{ th}}$			
1129							M_2			
2.8							c	17.7	3683	57.683
56							$n_{2 \text{ Eck}}$			
48							$n_{2 \text{ th}}$			
	1435	1108	2154	1551	2763	1717	M_2			
	3.9	4.5	2.6	3.3	2.1	3	c	17.7	5726	57.683
	25	52	25	52	23	52	$n_{2 \text{ Eck}}$			
	25	38	25	38	23	38	$n_{2 \text{ th}}$			
1272							M_2			
2.8							c	17.5	4149	64.995
50							$n_{2 \text{ Eck}}$			
42							$n_{2 \text{ th}}$			
	1621	1253	2432	1752	3119	1939	M_2			
	3.6	4.2	2.4	3	1.9	2.7	c	17.5	5992	64.995
	22	46	22	46	21	46	$n_{2 \text{ Eck}}$			
	22	34	22	34	21	34	$n_{2 \text{ th}}$			
1394							M_2			
2.4							c	13	3776	70.887
46							$n_{2 \text{ Eck}}$			
44							$n_{2 \text{ th}}$			
	1775	1373	2660	1918	3408	2122	M_2			
	3.2	3.7	2.2	2.7	1.7	2.5	c	13	5867	70.887
	20	42	20	42	19	42	$n_{2 \text{ Eck}}$			
	20	31	20	31	19	31	$n_{2 \text{ th}}$			
1571							M_2			
2.4							c	12.9	4255	79.873
40							$n_{2 \text{ Eck}}$			
39							$n_{2 \text{ th}}$			
	2007	1553	3003	2166	3847	2396	M_2			
	3	3.4	2	2.5	1.6	2.2	c	12.9	6032	79.873
	18	38	18	38	17	38	$n_{2 \text{ Eck}}$			
	18	28	18	28	17	28	$n_{2 \text{ th}}$			
1813							M_2			
1.9							c	8.3	3915	91.737
35							$n_{2 \text{ Eck}}$			
35							$n_{2 \text{ th}}$			
2043							M_2			
1.9							c	8.21	4411	103.365
31							$n_{2 \text{ Eck}}$			
31							$n_{2 \text{ th}}$			
2203							M_2			
1.7							c	6.05	3963	111.335
29							$n_{2 \text{ Eck}}$			
29							$n_{2 \text{ th}}$			

M ... [Nm]
n ... [min⁻¹]
J ... [kgcm²]

P ... [kW]
I ... [A]
i [-]
c [-]

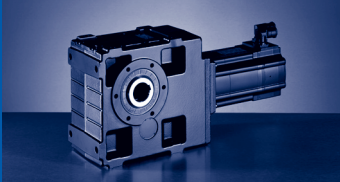

GKS [Nm]

GKS□□-□S (MCS)

$M_{2GN} \leq 6032 \text{ Nm}$

GKS11-3S				14DC15	14DC36	14HC15	14HC32	14LC15	14LC32	14PC14
				...500	...500	...500	...500	...500	...500	...500
i	M_{2GN}	J_G	M_1							
			n_1	9.2	7.5	16	14	23	17.2	30
			I_{M400}	1500	3600	1500	3225	1500	3225	1350
			P_N	4.5	7.5	6.6	11.9	9.7	15	10.8
			J_M	1.45	2.8	2.5	4.7	3.6	5.8	4.2
			M_2	8.22	8.22	14.32	14.32	23.44	23.44	34.74
125.448	4465	5.99	c	1061	859	1880	1640	2722	2025	3565
			n_2 Eck	4.1	4.7	2.3	2.6	1.6	2.1	1.3
			n_2 th	12	29	12	26	12	26	11
				12	29	12	26	12	26	11
140.732	4010	3.96	M_2	1201	973	2119	1850	3065	2282	4010
			c	3.3	3.8	1.9	2.1	1.3	1.7	1
			n_2 Eck	11	26	11	23	11	23	10
			n_2 th	11	26	11	23	11	23	10
158.571	4519	3.93	M_2	1353	1097	2388	2084	3453	2572	4519
			c	3.3	3.8	1.9	2.1	1.3	1.7	1
			n_2 Eck	10	23	10	20	10	20	9
			n_2 th	9	23	9	20	9	20	9
186.572	5975	7.07	M_2	1585	1284	2802	2446	4056	3019	5310
			c	3.7	4.2	2.1	2.4	1.5	1.9	1.1
			n_2 Eck	8	19	8	17	8	17	7
			n_2 th	8	19	8	17	8	17	7
210.222	5892	7.05	M_2	1794	1455	3167	2764	4579	3410	
			c	3.2	3.7	1.8	2.1	1.3	1.7	
			n_2 Eck	7	17	7	15	7	15	
			n_2 th	7	17	7	15	7	15	
226.431	5975	5.21	M_2	1937	1571	3415	2981	4936	3677	
			c	3	3.5	1.7	1.9	1.2	1.6	
			n_2 Eck	7	16	7	14	7	14	
			n_2 th	7	16	7	14	7	14	
255.133	5892	5.2	M_2	2191	1778	3856	3368	5571	4152	
			c	2.6	3.1	1.5	1.7	1.1	1.4	
			n_2 Eck	6	14	6	13	6	13	
			n_2 th	6	14	6	13	6	13	
286.219	5975	3.44	M_2	2465	2001	4333	3785		4664	
			c	2.4	2.8	1.4	1.5		1.3	
			n_2 Eck	5	13	5	11		11	
			n_2 th	5	13	5	11		11	
322.5	5892	3.43	M_2	2786	2263	4891	4273		5264	
			c	2.1	2.4	1.2	1.3		1.1	
			n_2 Eck	5	11	5	10		10	
			n_2 th	5	11	5	10		10	

M ... [Nm]
 n ... [min⁻¹]
 J ... [kgcm²]

P ... [kW]
 I ... [A]
 i [-]
 c [-]

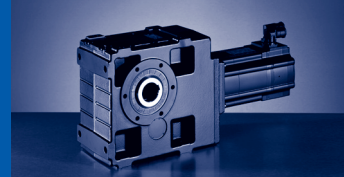

$M_{2GN} \leq 6032 \text{ Nm}$

14PC32	19FC14	19FC30	19JC14	19JC30	19PC14	19PC30	GKS11-3S			
...500	...500	...500	...500	...500	...500	...500	M_1	J_G	M_{2GN}	i
21	27	21	40	29	51	32	n_1			
3225	1425	3000	1425	3000	1350	3000	I_{M400}			
15.6	8.6	14	12.3	18.5	14.3	19	P_N			
7.1	4	6.6	6	9.1	7.2	10	J_M			
34.82	65.12	65.04	105.04	105.12	160.12	160.04	M_2			
2483							c			
1.7							$n_{2 \text{ Eck}}$	5.99	4465	125.448
26							$n_{2 \text{ th}}$			
26							M_2			
2796							c			
1.4							$n_{2 \text{ Eck}}$	3.96	4010	140.732
23							$n_{2 \text{ th}}$			
23							M_2			
3150							c			
1.4							$n_{2 \text{ Eck}}$	3.93	4519	158.571
20							$n_{2 \text{ th}}$			
20							M_2			
3699							c			
1.6							$n_{2 \text{ Eck}}$	7.07	5975	186.572
17							$n_{2 \text{ th}}$			
17							M_2			
4177							c			
1.4							$n_{2 \text{ Eck}}$	7.05	5892	210.222
15							$n_{2 \text{ th}}$			
15							M_2			
4503							c			
1.3							$n_{2 \text{ Eck}}$	5.21	5975	226.431
14							$n_{2 \text{ th}}$			
14							M_2			
5082							c			
1.1							$n_{2 \text{ Eck}}$	5.2	5892	255.133
13							$n_{2 \text{ th}}$			
13							M_2			
5708							c			
1							$n_{2 \text{ Eck}}$	3.44	5975	286.219
11							$n_{2 \text{ th}}$			
11							M_2			
							c			
							$n_{2 \text{ Eck}}$	3.43	5892	322.5
							$n_{2 \text{ th}}$			

M ... [Nm]
n ... [min⁻¹]
J ... [kgcm²]

P ... [kW]
I ... [A]
i [-]
c [-]

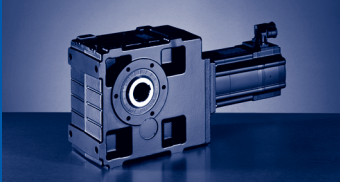

GKS [Nm]

GKS□□-□S (MCS)

$M_{2GN} \leq 6072 \text{ Nm}$

GKS11-4S				09DC41	09FC38	09HC41	09LC41	12DC20	12DC41	12HC15	12HC30	12HC35
				...500	...500	...500	...500	...500	...500	...500	...500	...500
i	M_{2GN}	J_G	M_1	2.3	3.1	3.8	4.5	5.5	4.3	10	8	7.5
			n_1	4050	3750	4050	4050	1950	4050	1500	3000	3525
			I_{M230}	4.6	5	6.8	8.4	5.2	8.8	7.6	10.5	
			I_{M400}	2.3	2.5	3.4	4.2	2.6	4.5	3.8		5.7
			P_N	1	1.2	1.6	1.9	1.1	1.8	1.6	2.5	2.8
			J_M	1.13	1.53	1.93	2.83	4.12	4.12	7.42	7.42	7.42
102.119	2972	7.28	M_2				408					
			c				5.7					
			n_2 Eck				40					
			n_2 th				40					
102.119	3825	7.28	M_2						923	734	688	
			c						4	4.5	4.6	
			n_2 Eck						15	29	35	
			n_2 th						15	29	35	
102.119	5292	7.28	M_2									
			c									
			n_2 Eck									
			n_2 th									
115.063	4309	7.21	M_2						1040	823	771	
			c						4	5	5.1	
			n_2 Eck						13	26	31	
			n_2 th						13	26	31	
115.063	5869	7.21	M_2									
			c									
			n_2 Eck									
			n_2 th									
125.095	4685	6.23	M_2						1130	894	838	
			c						4	5	5.1	
			n_2 Eck						12	24	28	
			n_2 th						12	24	28	
125.095	5800	6.23	M_2									
			c									
			n_2 Eck									
			n_2 th									
140.952	5279	6.19	M_2						1274	1008	944	
			c						4	5	5.1	
			n_2 Eck						11	21	25	
			n_2 th						11	21	25	
140.952	5923	6.19	M_2									
			c									
			n_2 Eck									
			n_2 th									
153.242	4931	4.5	M_2						1393	1104	1035	
			c						3.5	4.3	4.4	
			n_2 Eck						10	20	23	
			n_2 th						10	20	23	
153.242	5800	4.5	M_2									
			c									
			n_2 Eck									
			n_2 th									
172.667	5556	4.47	M_2						1570	1244	1166	
			c						3.5	4.3	4.4	
			n_2 Eck						9	17	20	
			n_2 th						9	17	20	
172.667	5923	4.47	M_2									
			c									
			n_2 Eck									
			n_2 th									

$M \dots$ [Nm]
 $n \dots$ [min^{-1}]
 $J \dots$ [kgcm^2]

$P \dots$ [kW]
 $I \dots$ [A]
 $i \dots$ [-]
 $c \dots$ [-]

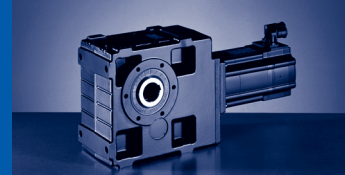

$M_{2GN} \leq 6072 \text{ Nm}$

12LC20	12LC41	14DC15	14DC36	14HC15	14HC32	14LC15	14LC32	14PC14	14PC32	GKS11-4S			
...500	...500	...500	...500	...500	...500	...500	...500	...500	...500	M_1	J_G	M_{2GN}	i
13.5	11	9.2	7.5	16	14	23	17.2	30	21	n_1			
1950	4050	1500	3600	1500	3225	1500	3225	1350	3225	i_{M230}			
11.8										i_{M400}			
5.9	10.2	4.5	7.5	6.6	11.9	9.7	15	10.8	15.6	P_N			
2.8	4.7	1.45	2.8	2.5	4.7	3.6	5.8	4.2	7.1	J_M			
10.72	10.72	8.22	8.22	14.32	14.32	23.44	23.44	34.74	34.82	M_2			
										c	7.28	2972	102.119
										n_2			
										Eck			
										n_2			
										th			
1260	1027									M_2			
3	3									c	7.28	3825	102.119
19	40									n_2			
19	40									Eck			
										n_2			
										th			
				1485	1299	2160	1608	2834	1974	M_2			
				3.5	3.5	2.4	2.8	1.9	2.3	c	7.28	5292	102.119
				15	32	15	32	13	32	n_2			
				15	32	15	32	13	32	Eck			
										n_2			
										th			
1420	1153									M_2			
3	3.3									c	7.21	4309	115.063
17	35									n_2			
17	35									Eck			
										n_2			
										th			
		936		1675	1459	2435	1806	3195	2219	M_2			
		5.9		3.4	3.8	2.4	3.1	1.8	2.5	c	7.21	5869	115.063
		13		13	28	13	28	12	28	n_2			
		13		13	28	13	28	12	28	Eck			
										n_2			
										th			
1544	1253									M_2			
3	3.3									c	6.23	4685	125.095
16	32									n_2			
16	32									Eck			
										n_2			
										th			
		1024		1827	1592	2653	1970	3480	2418	M_2			
		5.4		3.1	3.5	2.2	2.8	1.7	2.3	c	6.23	5800	125.095
		12		12	26	12	26	11	26	n_2			
		12		12	26	12	26	11	26	Eck			
										n_2			
										th			
1739	1412									M_2			
3	3.3									c	6.19	5279	140.952
14	29									n_2			
14	29									Eck			
										n_2			
										th			
		1160	938	2065	1800	2996	2226	3927	2731	M_2			
		4.9	5.7	2.8	3.1	2	2.6	1.5	2.1	c	6.19	5923	140.952
		11	26	11	23	11	23	10	23	n_2			
		11	25	11	23	11	23	10	23	Eck			
										n_2			
										th			
1900	1543									M_2			
2.6	2.8									c	4.5	4931	153.242
13	26									n_2			
13	26									Eck			
										n_2			
										th			
		1268	1026	2252	1964	3264	2427	4276	2976	M_2			
		4.4	5.1	2.5	2.8	1.8	2.3	1.4	1.9	c	4.5	5800	153.242
		10	24	10	21	10	21	9	21	n_2			
		10	23	10	21	10	21	9	21	Eck			
										n_2			
										th			
2140	1739									M_2			
2.6	2.8									c	4.47	5556	172.667
11	24									n_2			
11	23									Eck			
										n_2			
										th			
		1436	1162	2544	2219	3684	2741	4825	3360	M_2			
		4	4.6	2.3	2.6	1.6	2.1	1.2	1.7	c	4.47	5923	172.667
		9	21	9	19	9	19	8	19	n_2			
		9	21	9	19	9	19	8	19	Eck			
										n_2			
										th			

M ... [Nm]
n ... [min⁻¹]
J ... [kgcm²]

P ... [kW]
I ... [A]
i [-]
c [-]

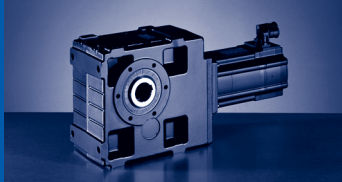

GKS [Nm]

GKS□□-□S (MCS)

$M_{2GN} \leq 6072 \text{ Nm}$

GKS11-4S				09DC41	09FC38	09HC41	09LC41	12DC20	12DC41	12HC15	12HC30	12HC35
				...500	...500	...500	...500	...500	...500	...500	...500	...500
i	M _{2GN}	J _G	M ₁	2.3	3.1	3.8	4.5	5.5	4.3	10	8	7.5
			n ₁	4050	3750	4050	4050	1950	4050	1500	3000	3525
			I _{M230}	4.6	5	6.8	8.4	5.2	8.8	7.6	10.5	
			I _{M400}	2.3	2.5	3.4	4.2	2.6	4.5	3.8		5.7
			P _N	1	1.2	1.6	1.9	1.1	1.8	1.6	2.5	2.8
			J _M	1.13	1.53	1.93	2.83	4.12	4.12	7.42	7.42	7.42
201.89	5972	3.74	M ₂					984		1841	1460	1368
			c					5.8		3.2	4	4
			n ₂ Eck					10		7	15	18
			n ₂ th					10		7	15	17
227.481	5992	3.72	M ₂					1117	865	2083	1653	1549
			c					5.1	5.9	2.8	3.5	3.6
			n ₂ Eck					9	18	7	13	16
			n ₂ th					9	18	7	13	16
248.106	5973	3.36	M ₂					1224	949	2277	1809	1695
			c					4.7	5.4	2.6	3.2	3.3
			n ₂ Eck					8	16	6	12	14
			n ₂ th					8	16	6	12	14
279.556	6032	3.34	M ₂					1386	1076	2574	2046	1917
			c					4.2	4.9	2.3	2.9	2.9
			n ₂ Eck					7	15	5	11	13
			n ₂ th					7	14	5	11	13
322.931	5973	2.09	M ₂		885	1100	1314	1612	1253	2984	2374	2225
			c		5.9	4.7	4	3.6	4.2	2	2.5	2.5
			n ₂ Eck		12	13	13	6	13	5	9	11
			n ₂ th		12	13	13	6	13	5	9	11
363.866	6032	2.08	M ₂		1005	1246	1487	1824	1418	3369	2682	2514
			c		5.3	4.2	3.6	3.2	3.7	1.8	2.2	2.2
			n ₂ Eck		10	11	11	5	11	4	8	10
			n ₂ th		10	11	11	5	11	4	8	10
395.787	5973	1.52	M ₂		1098	1361	1623	1990	1548	3671	2924	2741
			c		4.8	3.9	3.3	2.9	3.4	1.6	2	2
			n ₂ Eck		10	10	10	5	10	4	8	9
			n ₂ th		9	10	10	5	10	4	8	9
445.958	6032	1.52	M ₂	910	1245	1541	1835	2250	1751	4144	3302	3095
			c	5.7	4.3	3.5	2.9	2.6	3.1	1.5	1.8	1.8
			n ₂ Eck	9	8	9	9	4	9	3	7	8
			n ₂ th	9	8	9	9	4	9	3	7	8
512.196	5975	1.39	M ₂	1054	1439	1779	2117	2595	2021	4770	3803	3565
			c	4.9	3.7	3	2.5	2.3	2.6	1.3	1.6	1.6
			n ₂ Eck	8	7	8	8	4	8	3	6	7
			n ₂ th	8	7	8	8	4	8	3	6	7
577.122	6072	1.38	M ₂	1194	1628	2011	2392	2930	2283	5381	4292	4023
			c	4.4	3.4	2.7	2.3	2.1	2.4	1.1	1.4	1.4
			n ₂ Eck	7	7	7	7	3	7	3	5	6
			n ₂ th	7	7	7	7	3	7	3	5	6
621.619	5975	1.31	M ₂	1291	1759	2171	2582	3162	2465	5802	4629	4339
			c	4.1	3.1	2.5	2.1	1.9	2.2	1	1.3	1.3
			n ₂ Eck	7	6	7	7	3	7	2	5	6
			n ₂ th	7	6	7	7	3	7	2	5	6
700.416	6072	1.31	M ₂	1461	1989	2453	2916	3570	2783		5223	4896
			c	3.7	2.8	2.2	1.9	1.7	2		1.2	1.2
			n ₂ Eck	6	5	6	6	3	6		4	5
			n ₂ th	6	5	6	6	3	6		4	5
816.455	5975	0.82	M ₂	1714	2329	2870	3409	4174	3255			
			c	3.1	2.4	1.9	1.6	1.4	1.7			
			n ₂ Eck	5	5	5	5	2	5			
			n ₂ th	5	5	5	5	2	5			

M ... [Nm]
 n ... [min⁻¹]
 J ... [kgcm²]

P ... [kW]
 I ... [A]
 i [-]
 c [-]

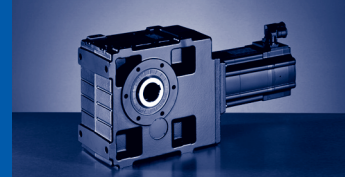

$M_{2GN} \leq 6072 \text{ Nm}$

12LC20	12LC41	14DC15	14DC36	14HC15	14HC32	14LC15	14LC32	14PC14	14PC32	GKS11-4S			
...500	...500	...500	...500	...500	...500	...500	...500	...500	...500	M_1	J_G	M_{2GN}	i
13.5	11	9.2	7.5	16	14	23	17.2	30	21	n_1			
1950	4050	1500	3600	1500	3225	1500	3225	1350	3225	I_{M230}			
11.8										I_{M400}			
5.9	10.2	4.5	7.5	6.6	11.9	9.7	15	10.8	15.6	P_N			
2.8	4.7	1.45	2.8	2.5	4.7	3.6	5.8	4.2	7.1	J_M			
10.72	10.72	8.22	8.22	14.32	14.32	23.44	23.44	34.74	34.82	M_2			
2508	2038	1689	1369	2984	2605	4318	3215	5652	3939	c	3.74	5972	201.89
2.4	2.6	3.4	4	2	2.2	1.4	1.8	1.1	1.5	$n_{2\text{Eck}}$			
10	20	7	18	7	16	7	16	7	16	$n_{2\text{th}}$			
10	20	7	18	7	16	7	16	7	16				
2834	2303	1911	1550	3371	2943	4873	3630		4446	M_2			
2.1	2.3	3.1	3.5	1.8	2	1.2	1.6		1.3	c	3.72	5992	227.481
9	18	7	16	7	14	7	14		14	$n_{2\text{Eck}}$			
9	18	7	16	7	14	7	14		14	$n_{2\text{th}}$			
3097	2518	2090	1696	3682	3216	5321	3965		4855	M_2			
1.9	2.1	2.8	3.2	1.6	1.8	1.1	1.5		1.2	c	3.36	5973	248.106
8	16	6	15	6	13	6	13		13	$n_{2\text{Eck}}$			
8	16	6	14	6	13	6	13		13	$n_{2\text{th}}$			
3497	2844	2363	1918	4157	3630	6003	4475		5477	M_2			
1.7	1.9	2.5	2.9	1.4	1.6	1	1.3		1.1	c	3.34	6032	279.556
7	15	5	13	5	12	5	12		12	$n_{2\text{Eck}}$			
7	14	5	13	5	12	5	12		12	$n_{2\text{th}}$			
4050	3294	2740	2225	4812	4204		5179			M_2			
1.5	1.6	2.2	2.5	1.2	1.4		1.1			c	2.09	5973	322.931
6	13	5	11	5	10		10			$n_{2\text{Eck}}$			
6	13	5	11	5	10		10			$n_{2\text{th}}$			
4571	3719	3095	2515	5430	4744		5843			M_2			
1.3	1.5	1.9	2.2	1.1	1.2		1			c	2.08	6032	363.866
5	11	4	10	4	9		9			$n_{2\text{Eck}}$			
5	11	4	10	4	9		9			$n_{2\text{th}}$			
4978	4051	3372	2741	5912	5167					M_2			
1.2	1.3	1.8	2	1	1.1					c	1.52	5973	395.787
5	10	4	9	4	8					$n_{2\text{Eck}}$			
5	10	4	9	4	8					$n_{2\text{th}}$			
5617	4571	3807	3096		5829					M_2			
1.1	1.2	1.6	1.8		1					c	1.52	6032	445.958
4	9	3	8		7					$n_{2\text{Eck}}$			
4	9	3	8		7					$n_{2\text{th}}$			
	5259	4383	3565							M_2			
	1	1.4	1.6							c	1.39	5975	512.196
	8	3	7							$n_{2\text{Eck}}$			
	8	3	7							$n_{2\text{th}}$			
		4946	4024							M_2			
		1.2	1.4							c	1.38	6072	577.122
		3	6							$n_{2\text{Eck}}$			
		3	6							$n_{2\text{th}}$			
		5333	4340							M_2			
		1.1	1.3							c	1.31	5975	621.619
		2	6							$n_{2\text{Eck}}$			
		2	6							$n_{2\text{th}}$			
		6016	4896							M_2			
		1	1.2							c	1.31	6072	700.416
		2	5							$n_{2\text{Eck}}$			
		2	5							$n_{2\text{th}}$			
										M_2			
										c	0.82	5975	816.455
										$n_{2\text{Eck}}$			
										$n_{2\text{th}}$			

$M \dots$ [Nm]
 $n \dots$ [min^{-1}]
 $J \dots$ [kgcm^2]

$P \dots$ [kW]
 $I \dots$ [A]
 i [-]
 c [-]

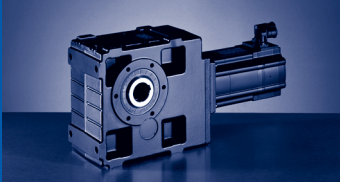

GKS [Nm]

GKS□□-□S (MCS)

$M_{2GN} \leq 6072 \text{ Nm}$

GKS11-4S				09DC41	09FC38	09HC41	09LC41	12DC20	12DC41	12HC15	12HC30	12HC35
				...500	...500	...500	...500	...500	...500	...500	...500	...500
i	M_{2GN}	J_G	M_1	2.3	3.1	3.8	4.5	5.5	4.3	10	8	7.5
			n_1	4050	3750	4050	4050	1950	4050	1500	3000	3525
			I_{M230}	4.6	5	6.8	8.4	5.2	8.8	7.6	10.5	
			I_{M400}	2.3	2.5	3.4	4.2	2.6	4.5	3.8		5.7
			P_N	1	1.2	1.6	1.9	1.1	1.8	1.6	2.5	2.8
			J_M	1.13	1.53	1.93	2.83	4.12	4.12	7.42	7.42	7.42
919.949	6072	0.82	M_2	1938	2631	3240	3848	4710	3674			
			c	2.8	2.1	1.7	1.4	1.3	1.5			
			$n_{2 \text{ Eck}}$	4	4	4	4	2	4			
			$n_{2 \text{ th}}$	4	4	4	4	2	4			
990.879	5975	0.6	M_2	2093	2839	3496	4150	5079	3963			
			c	2.5	1.9	1.5	1.3	1.2	1.4			
			$n_{2 \text{ Eck}}$	4	4	4	4	2	4			
			$n_{2 \text{ th}}$	4	4	4	4	2	4			
1116.484	6072	0.6	M_2	2365	3206	3945	4683	5730	4472			
			c	2.3	1.7	1.4	1.2	1.1	1.2			
			$n_{2 \text{ Eck}}$	4	3	4	4	2	4			
			$n_{2 \text{ th}}$	4	3	4	4	2	4			
1252.516	5975	0.39	M_2	2661	3605	4434	5261					
			c	2	1.5	1.2	1					
			$n_{2 \text{ Eck}}$	3	3	3	3					
			$n_{2 \text{ th}}$	3	3	3	3					
1411.286	6072	0.39	M_2	3004	4068	5002						
			c	1.8	1.4	1.1						
			$n_{2 \text{ Eck}}$	3	3	3						
			$n_{2 \text{ th}}$	3	3	3						

$M \dots [\text{Nm}]$
 $n \dots [\text{min}^{-1}]$
 $J \dots [\text{kgcm}^2]$

$P \dots [\text{kW}]$
 $I \dots [\text{A}]$
 $i [-]$
 $c [-]$

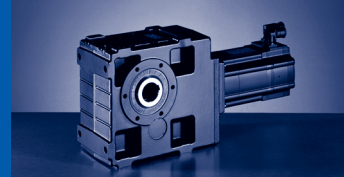

$M_{2GN} \leq 6072 \text{ Nm}$

12LC20	12LC41	14DC15	14DC36	14HC15	14HC32	14LC15	14LC32	14PC14	14PC32	GKS11-4S			
...500	...500	...500	...500	...500	...500	...500	...500	...500	...500	M_1	J_G	M_{2GN}	i
13.5	11	9.2	7.5	16	14	23	17.2	30	21	n_1			
1950	4050	1500	3600	1500	3225	1500	3225	1350	3225	I_{M230}			
11.8										I_{M400}			
5.9	10.2	4.5	7.5	6.6	11.9	9.7	15	10.8	15.6	P_N			
2.8	4.7	1.45	2.8	2.5	4.7	3.6	5.8	4.2	7.1	J_M			
10.72	10.72	8.22	8.22	14.32	14.32	23.44	23.44	34.74	34.82	M_2			
										c			
										$n_{2 \text{ Eck}}$	0.82	6072	919.949
										$n_{2 \text{ th}}$			
										M_2			
										c			
										$n_{2 \text{ Eck}}$	0.6	5975	990.879
										$n_{2 \text{ th}}$			
										M_2			
										c			
										$n_{2 \text{ Eck}}$	0.6	6072	1116.484
										$n_{2 \text{ th}}$			
										M_2			
										c			
										$n_{2 \text{ Eck}}$	0.39	5975	1252.516
										$n_{2 \text{ th}}$			
										M_2			
										c			
										$n_{2 \text{ Eck}}$	0.39	6072	1411.286
										$n_{2 \text{ th}}$			

M ... [Nm]
n ... [min^{-1}]
J ... [kgcm^2]

P ... [kW]
I ... [A]
i [-]
c [-]

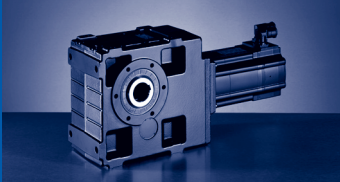

GKS [Nm]

GKS□□-□S (MCS)

$M_{2GN} \leq 11609 \text{ Nm}$

GKS14-3S				19FC14	19FC30	19JC14	19JC30	19PC14	19PC30
				...500	...500	...500	...500	...500	...500
i	M_{2GN}	J_G	M_1	27	21	40	29	51	32
			n_1	1425	3000	1425	3000	1350	3000
			I_{M400}	8.6	14	12.3	18.5	14.3	19
			P_N	4	6.6	6	9.1	7.2	10
			J_M	65.12	65.04	105.04	105.12	160.12	160.04
16.646	3765	198	M_2			599		775	480
			c			6		4.7	5.9
			n_2 Eck			86		81	180
			n_2 th			86		81	103
18.311	3889	173	M_2			662		855	530
			c			5.6		4.4	5.6
			n_2 Eck			78		74	164
			n_2 th			78		74	95
24.696	5585	183	M_2			889		1150	712
			c			6		4.7	5.9
			n_2 Eck			58		55	122
			n_2 th			58		55	69
27.165	5770	159	M_2			982		1269	786
			c			5.6		4.4	5.6
			n_2 Eck			53		50	110
			n_2 th			52		50	64
30.609	6501	156	M_2			1107		1430	886
			c			5.6		4.4	5.6
			n_2 Eck			47		44	98
			n_2 th			47		44	57
34.692	6208	111	M_2			1267	914	1633	1014
			c			4.7	5.2	3.7	4.7
			n_2 Eck			41	87	39	87
			n_2 th			41	57	39	56
39.089	6995	109	M_2			1427	1030	1840	1142
			c			4.7	5.2	3.7	4.7
			n_2 Eck			37	77	35	77
			n_2 th			36	51	35	50
42.531	6541	82.4	M_2	1033		1564	1122	2013	1244
			c	6		4.1	5	3.2	4.6
			n_2 Eck	34		34	71	32	71
			n_2 th	34		34	52	32	51
47.923	7370	81.1	M_2	1164		1762	1264	2268	1402
			c	6		4.1	5	3.2	4.6
			n_2 Eck	30		30	63	28	63
			n_2 th	30		30	46	28	45
56.251	6887	54.2	M_2	1385	1068	2087	1500	2681	1662
			c	4.8	5.5	3.2	4	2.5	3.6
			n_2 Eck	25	53	25	53	24	53
			n_2 th	25	39	25	39	24	39
63.382	7760	53.5	M_2	1561	1204	2352	1691	3021	1873
			c	4.8	5.5	3.2	4	2.5	3.6
			n_2 Eck	23	47	23	47	21	47
			n_2 th	22	35	22	35	21	35
68.942	7217	38.9	M_2	1711	1321	2571	1851	3299	2049
			c	4.1	4.7	2.8	3.4	2.2	3.1
			n_2 Eck	21	44	21	44	20	44
			n_2 th	21	32	21	32	20	32
77.681	8131	38.4	M_2	1928	1489	2897	2085	3717	2309
			c	4.1	4.7	2.8	3.4	2.2	3.1
			n_2 Eck	18	39	18	39	17	39
			n_2 th	18	28	18	28	17	28

$M \dots$ [Nm]
 $n \dots$ [min^{-1}]
 $J \dots$ [kgcm^2]

$P \dots$ [kW]
 $I \dots$ [A]
 $i \dots$ [-]
 $c \dots$ [-]

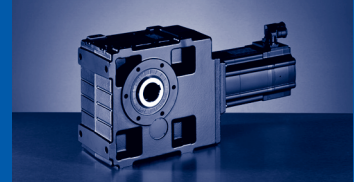

$M_{2GN} \leq 11609 \text{ Nm}$

GKS14-3S				19FC14	19FC30	19JC14	19JC30	19PC14	19PC30
				...500	...500	...500	...500	...500	...500
i	M_{2GN}	J_G	M_1	27	21	40	29	51	32
			n_1	1425	3000	1425	3000	1350	3000
			I_{M400}	8.6	14	12.3	18.5	14.3	19
			P_N	4	6.6	6	9.1	7.2	10
			J_M	65.12	65.04	105.04	105.12	160.12	160.04
90.551	7420	25.1	M_2	2269	1755	3399	2450	4355	2711
			c	3.2	3.7	2.2	2.7	1.7	2.4
			$n_{2 \text{ Eck}}$	16	33	16	33	15	33
			$n_{2 \text{ th}}$	16	24	16	24	15	24
102.029	8361	24.9	M_2	2556	1977	3829	2761	4907	3055
			c	3.2	3.7	2.2	2.7	1.7	2.4
			$n_{2 \text{ Eck}}$	14	29	14	29	13	29
			$n_{2 \text{ th}}$	14	22	14	22	13	22
109.896	7512	18.3	M_2	2769	2144	4140	2988	5301	3304
			c	2.7	3.1	1.8	2.2	1.4	2
			$n_{2 \text{ Eck}}$	13	27	13	27	12	27
			$n_{2 \text{ th}}$	13	20	13	20	12	20
123.826	8464	18.1	M_2	3120	2407	4665	3358	5973	3714
			c	2.7	3.4	1.8	2.5	1.4	2.3
			$n_{2 \text{ Eck}}$	12	24	12	24	11	24
			$n_{2 \text{ th}}$	12	18	12	18	11	18
186.572	11609	21.6	M_2	4713	3639	7041	5071	9011	5608
			c	2.4	3.1	1.6	2.3	1.3	2.1
			$n_{2 \text{ Eck}}$	8	16	8	16	7	16
			$n_{2 \text{ th}}$	8	12	8	12	7	12
210.222	11555	21.5	M_2	5327	4116	7950	5730	10169	6335
			c	2.1	2.8	1.5	2	1.1	1.8
			$n_{2 \text{ Eck}}$	7	14	7	14	6	14
			$n_{2 \text{ th}}$	7	11	7	11	6	11
226.431	11609	15.9	M_2	5746	4442	8571	6181	10962	6833
			c	2	2.6	1.4	1.9	1.1	1.7
			$n_{2 \text{ Eck}}$	6	13	6	13	6	13
			$n_{2 \text{ th}}$	6	10	6	10	6	10
255.133	11555	15.8	M_2	6490	5021	9674	6980		7715
			c	1.8	2.3	1.2	1.6		1.5
			$n_{2 \text{ Eck}}$	6	12	6	12		12
			$n_{2 \text{ th}}$	6	9	6	9		9

M ... [Nm]
n ... [min^{-1}]
J ... [kgcm^2]

P ... [kW]
I ... [A]
i [-]
c [-]

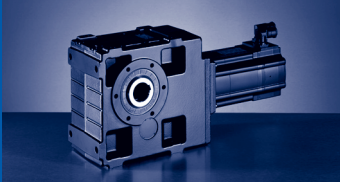

GKS [Nm]

GKS□□-□S (MCS)

$M_{2GN} \leq 11639 \text{ Nm}$

GKS14-4S				12DC20	12DC41	12HC15	12HC30	12HC35	12LC20	12LC41	14DC15	14DC36	14HC15
				...500	...500	...500	...500	...500	...500	...500	...500	...500	...500
i	M_{2GN}	J_G	M_1	5.50	4.30	10.00	8.00	7.50	13.50	11.00	9.20	7.50	16.00
			n_1	1950	4050	1500	3000	3525	1950	4050	1500	3600	1500
			I_{M230}	5.2	8.8	7.6	10.5		11.8				
			I_{M400}	2.6	4.5	3.8		5.7	5.9	10.2	4.5	7.5	6.6
			P_N	1.10	1.80	1.60	2.50	2.80	2.80	4.70	1.45	2.80	2.50
			J_M	4.12	4.12	7.42	7.42	7.42	10.72	10.72	8.22	8.22	14.32
97.467	4589	23.47	M_2			871	692	648	1193	972			
			c			5.0	5.7	5.8	3.7	3.7			
			$n_{2 \text{ Eck}}$			15	31	36	20	42			
			$n_{2 \text{ th}}$			15	31	36	20	36			
97.467	7182	23.47	M_2										1395
			c										4.9
			$n_{2 \text{ Eck}}$										15
			$n_{2 \text{ th}}$										15
97.467	10019	23.47	M_2										
			c										
			$n_{2 \text{ Eck}}$										
			$n_{2 \text{ th}}$										
109.822	5170	23.23	M_2			981	779	730	1344	1095			
			c			5.0	5.7	5.8	3.7	3.7			
			$n_{2 \text{ Eck}}$			14	27	32	18	37			
			$n_{2 \text{ th}}$			14	27	32	18	32			
109.822	8093	23.23	M_2										1572
			c										4.9
			$n_{2 \text{ Eck}}$										14
			$n_{2 \text{ th}}$										14
109.822	10937	23.23	M_2										
			c										
			$n_{2 \text{ Eck}}$										
			$n_{2 \text{ th}}$										
119.493	5626	19.94	M_2			1067			1462	1186			
			c			5.0			3.7	4.2			
			$n_{2 \text{ Eck}}$			13			16	34			
			$n_{2 \text{ th}}$			13			16	30			
119.493	8805	19.94	M_2										1710
			c										4.9
			$n_{2 \text{ Eck}}$										13
			$n_{2 \text{ th}}$										13
119.493	10787	19.94	M_2										
			c										
			$n_{2 \text{ Eck}}$										
			$n_{2 \text{ th}}$										
134.640	6339	19.78	M_2			1203			1647	1336			
			c			5.0			3.7	4.2			
			$n_{2 \text{ Eck}}$			11			15	30			
			$n_{2 \text{ th}}$			11			14	26			
134.640	9921	19.78	M_2										1927
			c										4.9
			$n_{2 \text{ Eck}}$										11
			$n_{2 \text{ th}}$										11
134.640	11261	19.78	M_2										
			c										
			$n_{2 \text{ Eck}}$										
			$n_{2 \text{ th}}$										
158.039	7440	16.44	M_2			1412			1934	1568			
			c			5.0			3.7	4.2			
			$n_{2 \text{ Eck}}$			10			12	26			
			$n_{2 \text{ th}}$			9			12	23			

$M \dots$ [Nm]
 $n \dots$ [min^{-1}]
 $J \dots$ [kgcm^2]

$P \dots$ [kW]
 $I \dots$ [A]
 $i \dots$ [-]
 $c \dots$ [-]

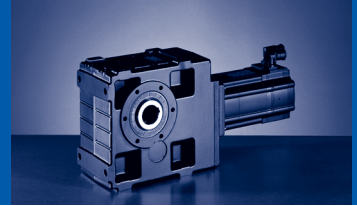

$M_2 GN \leq 11639 \text{ Nm}$

14HC32	14LC15	14LC32	14PC14	14PC32	19FC14	19FC30	19JC14	19JC30	19PC14	19PC30	GKS14-4S			
...500	...500	...500	...500	...500	...500	...500	...500	...500	...500	...500	M_1	J_G	$M_2 GN$	i
14.00	23.00	17.20	30.00	21.00	27.00	21.00	40.00	29.00	51.00	32.00	n_1			
3225	1500	3225	1350	3225	1425	3000	1425	3000	1350	3000	$I_{M 230}$			
											$I_{M 400}$			
11.9	9.7	15.0	10.8	15.6	8.6	14.0	12.3	18.5	14.3	19.0	P_N			
4.70	3.60	5.80	4.20	7.10	4.00	6.60	6.00	9.10	7.20	10.00	J_M			
14.32	23.44	23.44	34.74	34.82	65.12	65.04	105.04	105.12	160.12	160.04	M_2			
											c	23.47	4589	97.467
											n_2			
											n_2			
											n_2			
1220	2039	1514	2682	1864							M_2	23.47	7182	97.467
5.0	3.4	4.0	2.6	3.3							c			
33	15	33	14	33							n_2			
33	15	33	14	33							n_2			
					2377	1835	3572	2571	4584	2847	M_2	23.47	10019	97.467
					4.1	4.7	2.7	3.4	2.2	3.1	c			
					15	31	15	31	14	31	n_2			
					15	23	15	23	14	23	n_2			
											M_2	23.23	5170	109.822
											c			
											n_2			
											n_2			
1375	2297	1706	3023	2100							M_2	23.23	8093	109.822
5.0	3.4	4.0	2.6	3.3							c			
29	14	29	12	29							n_2			
29	14	29	12	29							n_2			
					2681	2071	4028	2900	5169	3211	M_2	23.23	10937	109.822
					4.0	4.6	2.7	3.3	2.1	3.0	c			
					13	27	13	27	12	27	n_2			
					13	20	13	20	12	20	n_2			
											M_2	19.94	5626	119.493
											c			
											n_2			
											n_2			
1487	2499	1848	3289	2276							M_2	19.94	8805	119.493
5.5	3.4	4.5	2.6	3.7							c			
27	13	27	11	27							n_2			
27	13	27	11	27							n_2			
					2930	2253	4396	3155	5636	3494	M_2	19.94	10787	119.493
					3.6	4.6	2.4	3.3	1.9	3.0	c			
					12	25	12	25	11	25	n_2			
					12	19	12	19	11	19	n_2			
											M_2	19.78	6339	134.640
											c			
											n_2			
											n_2			
1675	2816	2082	3706	2565							M_2	19.78	9921	134.640
5.5	3.4	4.5	2.6	3.7							c			
24	11	24	10	24							n_2			
24	11	24	10	24							n_2			
					3310	2548	4962	3564	6360	3945	M_2	19.78	11261	134.640
					3.3	4.3	2.2	3.1	1.8	2.8	c			
					11	22	11	22	10	22	n_2			
					11	16	11	16	10	16	n_2			
											M_2	16.44	7440	158.039
											c			
											n_2			
											n_2			

$M \dots$ [Nm]
 $n \dots$ [min^{-1}]
 $J \dots$ [kgcm^2]

$P \dots$ [kW]
 $I \dots$ [A]
 i [-]
 c [-]

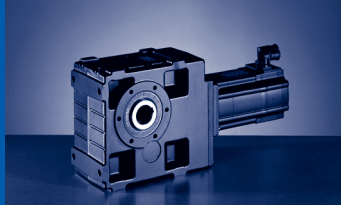

GKS [Nm]

GKS□□-□S (MCS)

M_{2 GN} ≤ 11639 Nm

GKS14-4S				12DC20	12DC41	12HC15	12HC30	12HC35	12LC20	12LC41	14DC15	14DC36	14HC15	
				...500	...500	...500	...500	...500	...500	...500	...500	...500	...500	
i	M _{2 GN}	J _G	M ₁	5.50	4.30	10.00	8.00	7.50	13.50	11.00	9.20	7.50	16.00	
			n ₁	1950	4050	1500	3000	3525	1950	4050	1500	3600	1500	
			I _{M 230}	5.2	8.8	7.6	10.5		11.8					
			I _{M 400}	2.6	4.5	3.8		5.7	5.9	10.2	4.5	7.5	6.6	
			P _N	1.10	1.80	1.60	2.50	2.80	2.80	4.70	1.45	2.80	2.50	
			J _M	4.12	4.12	7.42	7.42	7.42	10.72	10.72	8.22	8.22	14.32	
158.039	11522	16.44	M ₂										2263	
			c										4.9	
			n ₂ Eck											10
			n ₂ th											
178.072	8383	16.35	M ₂			1591			2179	1767				
			c			5.0			3.7	4.2				
			n ₂ Eck			8			11	23				
			n ₂ th			8			11	20				
178.072	11477	16.35	M ₂										2566	
			c										4.3	
			n ₂ Eck										8	
			n ₂ th										8	
193.754	11522	12.08	M ₂										2802	
			c										4.0	
			n ₂ Eck										8	
			n ₂ th										8	
218.315	11477	12.02	M ₂										3174	
			c										3.5	
			n ₂ Eck										7	
			n ₂ th										7	
237.467	11454	10.87	M ₂								1939		3463	
			c								5.6		3.2	
			n ₂ Eck								6		6	
			n ₂ th								6		6	
267.568	11520	10.83	M ₂								2200	1778	3917	
			c								5.0	5.8	2.9	
			n ₂ Eck								6	14	6	
			n ₂ th								6	13	6	
321.729	10184	6.42	M ₂			2927	2320	2174	3990	3241				
			c			3.4	4.2	4.3	2.5	2.8				
			n ₂ Eck			5	9	11	6	13				
			n ₂ th			5	9	11	6	13				
321.729	11454	6.42	M ₂								2671	2162	4735	
			c								4.1	4.8	2.4	
			n ₂ Eck								5	11	5	
			n ₂ th								5	11	5	
362.512	11475	6.40	M ₂			3298	2614	2449	4496	3652				
			c			3.4	4.2	4.3	2.5	2.8				
			n ₂ Eck			4	8	10	5	11				
			n ₂ th			4	8	10	5	11				
362.512	11520	6.40	M ₂								3024	2450	5350	
			c								3.7	4.3	2.1	
			n ₂ Eck								4	10	4	
			n ₂ th								4	10	4	
390.671	10597	4.75	M ₂	1914		3573	2836	2658	4864	3953				
			c	5.3		2.9	3.6	3.7	2.2	2.4				
			n ₂ Eck	5		4	8	9	5	10				
			n ₂ th	5		4	8	9	5	10				
390.671	11454	4.75	M ₂								3269	2650	5776	
			c								3.4	3.9	2.0	
			n ₂ Eck								4	9	4	
			n ₂ th								4	9	4	

M ... [Nm]
 n ... [min⁻¹]
 J ... [kgcm²]

P ... [kW]
 I ... [A]
 i [-]
 c [-]

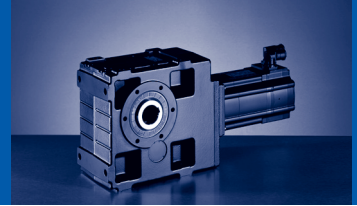

$M_2 GN \leq 11639 \text{ Nm}$

14HC32	14LC15	14LC32	14PC14	14PC32	19FC14	19FC30	19JC14	19JC30	19PC14	19PC30	GKS14-4S			
...500	...500	...500	...500	...500	...500	...500	...500	...500	...500	...500	M_1	J_G	$M_2 GN$	i
14.00	23.00	17.20	30.00	21.00	27.00	21.00	40.00	29.00	51.00	32.00	n_1			
3225	1500	3225	1350	3225	1425	3000	1425	3000	1350	3000	$I_M 230$			
											$I_M 400$			
11.9	9.7	15.0	10.8	15.6	8.6	14.0	12.3	18.5	14.3	19.0	P_N			
4.70	3.60	5.80	4.20	7.10	4.00	6.60	6.00	9.10	7.20	10.00	J_M			
14.32	23.44	23.44	34.74	34.82	65.12	65.04	105.04	105.12	160.12	160.04	M_2			
1968	3307	2445	4351	3012	3903	3009	5842	4202	7483	4649	c	16.44	11522	158.039
5.4	3.4	4.4	2.6	3.6	2.9	3.7	2.0	2.7	1.5	2.4	$n_2 Eck$			
20	10	20	9	20	9	19	9	19	9	19	$n_2 th$			
20	9	20	9	20	9	14	9	14	9	14	M_2			
											c	16.35	8383	178.072
											$n_2 Eck$			
											$n_2 th$			
2233	3742	2770	4919	3409	4414	3406	6599	4751	8448	5255	M_2			
4.8	3.0	3.9	2.3	3.2	2.6	3.3	1.7	2.4	1.4	2.2	c	16.35	11477	178.072
18	8	18	8	18	8	17	8	17	8	17	$n_2 Eck$			
18	8	18	8	18	8	12	8	12	8	12	$n_2 th$			
2439	4082	3025	5362	3719	4814	3716	7191	5179	9202	5728	M_2			
4.4	2.8	3.6	2.1	3.0	2.4	3.0	1.6	2.2	1.3	2.0	c	12.08	11522	193.754
17	8	17	7	17	7	16	7	16	7	16	$n_2 Eck$			
17	8	17	7	17	7	11	7	11	7	11	$n_2 th$			
2764	4616	3424	6058	4207	5440	4204	8118	5852	10384	6470	M_2			
3.9	2.5	3.2	1.9	2.6	2.1	2.7	1.4	1.9	1.1	1.8	c	12.02	11477	218.315
15	7	15	6	15	7	14	7	14	6	14	$n_2 Eck$			
15	7	15	6	15	7	10	7	10	6	10	$n_2 th$			
3018	5032	3735	6600	4586	5928	4583	8841	6376	11306	7049	M_2			
3.6	2.3	2.9	1.7	2.4	1.9	2.5	1.3	1.8	1.0	1.6	c	10.87	11454	237.467
14	6	14	6	14	6	13	6	13	6	13	$n_2 Eck$			
14	6	14	6	14	6	9	6	9	6	9	$n_2 th$			
3415	5684	4223	7452	5182	6694	5179	9977	7199		7957	M_2			
3.2	2.0	2.6	1.5	2.1	1.7	2.2	1.2	1.6		1.4	c	10.83	11520	267.568
12	6	12	5	12	5	11	5	11		11	$n_2 Eck$			
12	6	12	5	12	5	8	5	8		8	$n_2 th$			
											M_2			
											c	6.42	10184	321.729
											$n_2 Eck$			
											$n_2 th$			
4131	6861	5103	8986	6256							M_2			
2.7	1.7	2.2	1.3	1.8							c	6.42	11454	321.729
10	5	10	4	10							$n_2 Eck$			
10	5	10	4	10							$n_2 th$			
											M_2			
											c	6.40	11475	362.512
											$n_2 Eck$			
											$n_2 th$			
4669	7745	5764	10140	7064							M_2			
2.4	1.5	1.9	1.1	1.6							c	6.40	11520	362.512
9	4	9	4	9							$n_2 Eck$			
9	4	9	4	9							$n_2 th$			
											M_2			
											c	4.75	10597	390.671
											$n_2 Eck$			
											$n_2 th$			
5042	8357	6222	10938	7623							M_2			
2.2	1.4	1.8	1.1	1.5							c	4.75	11454	390.671
8	4	8	4	8							$n_2 Eck$			
8	4	8	3	8							$n_2 th$			

M ... [Nm]
n ... [min⁻¹]
J ... [kgcm²]

P ... [kW]
I ... [A]
i [-]
c [-]

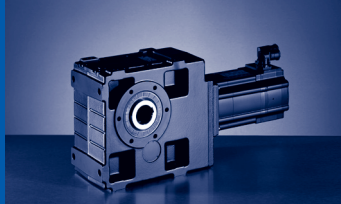

GKS [Nm] GKS□□-□S (MCS)

M_{2 GN} ≤ 11639 Nm

GKS14-4S				12DC20	12DC41	12HC15	12HC30	12HC35	12LC20	12LC41	14DC15	14DC36	14HC15
				...500	...500	...500	...500	...500	...500	...500	...500	...500	...500
i	M _{2 GN}	J _G	M ₁	5.50	4.30	10.00	8.00	7.50	13.50	11.00	9.20	7.50	16.00
			n ₁	1950	4050	1500	3000	3525	1950	4050	1500	3600	1500
			I _{M 230}	5.2	8.8	7.6	10.5		11.8				
			I _{M 400}	2.6	4.5	3.8		5.7	5.9	10.2	4.5	7.5	6.6
			P _N	1.10	1.80	1.60	2.50	2.80	2.80	4.70	1.45	2.80	2.50
			J _M	4.12	4.12	7.42	7.42	7.42	10.72	10.72	8.22	8.22	14.32
440.193	11520	4.73	M ₂	2161	1675	4031	3200	2999	5485	4458	3698	3000	6523
			c	5.1	5.9	2.8	3.5	3.5	2.1	2.3	3.1	3.5	1.8
			n ₂ Eck	4	9	3	7	8	4	9	3	8	3
			n ₂ th	4	9	3	7	8	4	9	3	8	3
513.121	11488	4.33	M ₂	2540	1971	4719	3751	3515	6414	5215	4332	3516	7625
			c	4.4	5.1	2.4	3.0	3.0	1.8	2.0	2.6	3.0	1.5
			n ₂ Eck	4	8	3	6	7	4	8	3	7	3
			n ₂ th	4	8	3	6	7	4	8	3	7	3
578.164	11639	4.32	M ₂	2876	2233	5332	4240	3974	7241	5889	4895	3975	8605
			c	3.9	4.5	2.2	2.7	2.7	1.6	1.8	2.3	2.7	1.4
			n ₂ Eck	3	7	3	5	6	3	7	3	6	3
			n ₂ th	3	7	3	5	6	3	7	3	6	3
622.742	11488	4.12	M ₂	3109	2416	5754	4578	4291	7811	6353	5284	4292	9280
			c	3.6	4.2	2.0	2.5	2.5	1.5	1.6	2.2	2.5	1.2
			n ₂ Eck	3	7	2	5	6	3	7	2	6	2
			n ₂ th	3	7	2	5	6	3	7	2	6	2
701.681	11639	4.12	M ₂	3517	2735	6497	5173	4848	8815	7171	5967	4849	10470
			c	3.2	3.7	1.8	2.2	2.3	1.3	1.5	1.9	2.2	1.1
			n ₂ Eck	3	6	2	4	5	3	6	2	5	2
			n ₂ th	3	6	2	4	5	3	6	2	5	2
805.901	11488	2.62	M ₂	4060	3159	7482	5961	5587	10144	8255	6874	5588	
			c	2.8	3.2	1.5	1.9	1.9	1.1	1.3	1.7	1.9	
			n ₂ Eck	2	5	2	4	4	2	5	2	5	
			n ₂ th	2	5	2	4	4	2	5	2	4	
908.058	11639	2.62	M ₂	4589	3572	8445	6731	6309	11444	9314	7759	6310	
			c	2.5	2.9	1.4	1.7	1.7	1.0	1.1	1.5	1.7	
			n ₂ Eck	2	5	2	3	4	2	5	2	4	
			n ₂ th	2	4	2	3	4	2	4	2	4	
978.071	11488	1.91	M ₂	4954	3858	9107	7261	6806		10042	8369	6807	
			c	2.3	2.7	1.3	1.6	1.6		1.0	1.4	1.6	
			n ₂ Eck	2	4	2	3	4		4	2	4	
			n ₂ th	2	4	2	3	4		4	2	4	
1102.052	11639	1.91	M ₂	5595	4359	10276	8196	7682			9444	7683	
			c	2.1	2.4	1.1	1.4	1.4			1.2	1.4	
			n ₂ Eck	2	4	1	3	3			1	3	
			n ₂ th	2	4	1	3	3			1	3	
1236.326	11488	1.26	M ₂	6294	4906		9211	8634					
			c	1.8	2.1		1.2	1.3					
			n ₂ Eck	2	3		2	3					
			n ₂ th	2	3		2	3					
1393.043	11639	1.26	M ₂	7106	5540		10392	9742					
			c	1.6	1.9		1.1	1.1					
			n ₂ Eck	1	3		2	3					
			n ₂ th	1	3		2	3					

M ... [Nm]
n ... [min⁻¹]
J ... [kgcm²]

P ... [kW]
I ... [A]
i [-]
c [-]

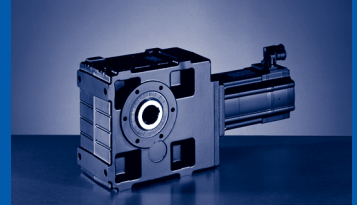

$M_2 GN \leq 11639 \text{ Nm}$

14HC32	14LC15	14LC32	14PC14	14PC32	19FC14	19FC30	19JC14	19JC30	19PC14	19PC30	GKS14-4S			
...500	...500	...500	...500	...500	...500	...500	...500	...500	...500	...500	M_1	J_G	$M_2 GN$	i
14.00	23.00	17.20	30.00	21.00	27.00	21.00	40.00	29.00	51.00	32.00	n_1			
3225	1500	3225	1350	3225	1425	3000	1425	3000	1350	3000	$I_M 230$			
											$I_M 400$			
11.9	9.7	15.0	10.8	15.6	8.6	14.0	12.3	18.5	14.3	19.0	P_N			
4.70	3.60	5.80	4.20	7.10	4.00	6.60	6.00	9.10	7.20	10.00	J_M			
14.32	23.44	23.44	34.74	34.82	65.12	65.04	105.04	105.12	160.12	160.04	M_2			
5695	9431	7025		8603							c	4.73	11520	440.193
2.0	1.2	1.6		1.3							$n_2 \text{ Eck}$			
7	3	7		7							$n_2 \text{ th}$			
7	3	7		7										
6659	11014	8209		10049							M_2	4.33	11488	513.121
1.7	1.0	1.4		1.1							c			
6	3	6		6							$n_2 \text{ Eck}$			
6	3	6		6							$n_2 \text{ th}$			
7517		9263		11336							M_2	4.32	11639	578.164
1.5		1.2		1.0							c			
6		6		6							$n_2 \text{ Eck}$			
6		6		6							$n_2 \text{ th}$			
8108		9988									M_2	4.12	11488	622.742
1.4		1.1									c			
5		5									$n_2 \text{ Eck}$			
5		5									$n_2 \text{ th}$			
9149		11268									M_2	4.12	11639	701.681
1.2		1.0									c			
5		5									$n_2 \text{ Eck}$			
5		5									$n_2 \text{ th}$			
10527											M_2	2.62	11488	805.901
1.1											c			
4											$n_2 \text{ Eck}$			
4											$n_2 \text{ th}$			
											M_2	2.62	11639	908.058
											c			
											$n_2 \text{ Eck}$			
											$n_2 \text{ th}$			
											M_2	1.91	11488	978.071
											c			
											$n_2 \text{ Eck}$			
											$n_2 \text{ th}$			
											M_2	1.91	11639	1102.052
											c			
											$n_2 \text{ Eck}$			
											$n_2 \text{ th}$			
											M_2	1.26	11488	1236.326
											c			
											$n_2 \text{ Eck}$			
											$n_2 \text{ th}$			
											M_2	1.26	11639	1393.043
											c			
											$n_2 \text{ Eck}$			
											$n_2 \text{ th}$			

M ... [Nm]
n ... [min⁻¹]
J ... [kgcm²]

P ... [kW]
I ... [A]
i [-]
c [-]

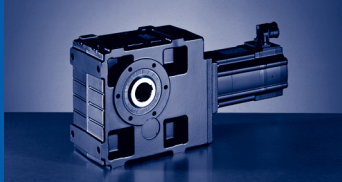

GKS [Nm]

GKS□□-□A (MCA)

$M_{2GN} \leq 187 \text{ Nm}$

GKS04-3A				10IC40	13IC34	13IC41
				...500	...F10	...500
i	M_{2GN}	J_G	M_1			
			n_1	2	6.3	4
			I_{M400}	3950	3410	4050
			P_N	2.4	6	4.4
			J_M	0.8	2.2	1.7
			M_2	2.44	8.34	8.34
5.123	81	1.17	c	9	30	19
			n_2 Eck	6	2	3
			n_2 th	771	666	791
				727	593	639
7.025	93	0.68	M_2	13	42	26
			c	5	1.7	2.5
			n_2 Eck	562	485	577
			n_2 th	562	445	503
8.167	128	0.86	M_2	15	48	30
			c	6	2	3
			n_2 Eck	484	418	496
			n_2 th	456	372	401
8.991	103	0.44	M_2	16	54	34
			c	4.4	1.5	2.2
			n_2 Eck	439	379	451
			n_2 th	439	379	450
9.836	106	0.38	M_2	18	59	37
			c	4.1	1.4	2
			n_2 Eck	402	347	412
			n_2 th	402	347	412
11.73	180	0.73	M_2	21	69	44
			c	5.9	2	2.9
			n_2 Eck	337	291	345
			n_2 th	316	256	278
13.067	165	0.7	M_2	24	78	49
			c	4.8	1.6	2.4
			n_2 Eck	302	261	310
			n_2 th	274	206	240
14.333	164	0.35	M_2	26	85	54
			c	4.4	1.5	2.2
			n_2 Eck	276	238	283
			n_2 th	276	238	283
16.087	181	0.44	M_2	30	96	60
			c	4.3	1.4	2.1
			n_2 Eck	246	212	252
			n_2 th	242	181	214
17.92	166	0.43	M_2	33	107	68
			c	3.5	1.2	1.8
			n_2 Eck	220	190	226
			n_2 th	210	150	178
20.588	182	0.3	M_2	38	123	78
			c	3.4	1.1	1.7
			n_2 Eck	192	166	197
			n_2 th	192	148	178
22.522	182	0.26	M_2	42	135	85
			c	3.1	1	1.5
			n_2 Eck	175	151	180
			n_2 th	175	138	163
25.088	167	0.25	M_2	47		95
			c	2.5		1.3
			n_2 Eck	158		161
			n_2 th	157		134

$M \dots$ [Nm]
 $n \dots$ [min^{-1}]
 $J \dots$ [kgcm^2]

$P \dots$ [kW]
 $I \dots$ [A]
 $i \dots$ [-]
 $c \dots$ [-]

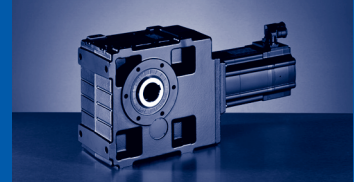

$M_{2GN} \leq 187 \text{ Nm}$

GKS04-3A				10IC40	13IC34	13IC41
				...500	...F10	...500
i	M_{2GN}	J_G	M_1			
			n_1	2	6.3	4
			I_{M400}	3950	3410	4050
			P_N	2.4	6	4.4
			J_M	0.8	2.2	1.7
			M_2	2.44	8.34	8.34
28.727	183	0.18	c	54		109
			n_2 Eck	2.4		1.2
			n_2 th	138		141
				138		133
32	167	0.18	M_2	60		
			c	2		
			n_2 Eck	123		
			n_2 th	123		
35.191	183	0.14	M_2	66		
			c	2		
			n_2 Eck	112		
			n_2 th	112		
39.2	168	0.13	M_2	74		
			c	1.6		
			n_2 Eck	101		
			n_2 th	101		
44.24	185	0.09	M_2	83		
			c	1.8		
			n_2 Eck	89		
			n_2 th	89		
50.943	182	0.18	M_2	96		
			c	1.6		
			n_2 Eck	78		
			n_2 th	72		
56.976	187	0.06	M_2	108		
			c	1.4		
			n_2 Eck	69		
			n_2 th	69		
64.978	183	0.13	M_2	123		
			c	1.2		
			n_2 Eck	61		
			n_2 th	59		

M ... [Nm]
n ... [min⁻¹]
J ... [kgcm²]

P ... [kW]
I ... [A]
i [-]
c [-]

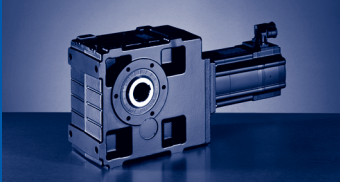

GKS [Nm]

GKS□□-□A (MCA)

$M_{2GN} \leq 331 \text{ Nm}$

GKS05-3A				10IC40	13IC34	13IC41	14LC16	14LC20	14LC35	14LC41
				...500	...F10	...500	...F10	...500	...F10	...500
i	M_{2GN}	J_G	M_1							
			n_1	2	6.3	4	12	6.7	10.8	5.4
			I_{M400}	3950	3410	4050	1635	2000	3455	4100
			P_N	2.4	6	4.4	4.8	3.3	9.1	5.8
			J_M	0.8	2.2	1.7	2.1	1.4	3.9	2.3
			M_2	2.44	8.34	8.34	19.32	19.24	19.24	19.24
6.863	147	1.9	c		40	25	78	43	70	34
			n_2 Eck		2.7	4.1	1.8	3.1	1.6	3
			n_2 th		497	590	238	291	503	597
					389	422	238	291	321	397
9.412	165	1.17	M_2		56	35	107	59	96	48
			c		2.2	3.3	1.5	2.5	1.3	2.4
			n_2 Eck		362	430	174	213	367	436
			n_2 th		320	347	174	213	248	327
10.569	227	1.6	M_2		62	39	119	66	108	53
			c		2.7	4.1	1.8	3.1	1.6	3
			n_2 Eck		323	383	155	189	327	388
			n_2 th		253	274	155	189	209	258
11.667	251	1.65	M_2		69	43	132	73	119	59
			c		2.7	4.1	1.8	3.1	1.6	3
			n_2 Eck		292	347	140	171	296	351
			n_2 th		229	248	140	171	189	234
13.176	165	0.71	M_2	24	78	49	150	83		67
			c	4.8	1.6	2.4	1.1	1.8		1.8
			n_2 Eck	300	259	307	124	152		311
			n_2 th	300	231	266	124	152		242
14.494	254	1.05	M_2		86	54	164	91	148	73
			c		2.2	3.3	1.5	2.5	1.3	2.4
			n_2 Eck		235	279	113	138	238	283
			n_2 th		208	225	113	138	161	212
16	280	1.04	M_2		95	59	181	100	164	81
			c		2.2	3.3	1.5	2.5	1.3	2.4
			n_2 Eck		213	253	102	125	216	256
			n_2 th		188	204	102	125	146	192
17.054	314	1.51	M_2		101	63	193	107	174	86
			c		2.3	3.5	1.6	2.6	1.4	2.6
			n_2 Eck		200	238	96	117	203	240
			n_2 th		151	165	96	117	119	155
19.216	297	1.47	M_2		114	72	218	121	197	97
			c		2	2.9	1.3	2.2	1.1	2.2
			n_2 Eck		178	211	85	104	180	213
			n_2 th		129	141	85	104	98	132
23.388	329	0.96	M_2		139	87	266	147	240	119
			c		1.8	2.7	1.2	2	1	2
			n_2 Eck		146	173	70	86	148	175
			n_2 th		119	134	70	86	90	125
26.353	298	0.95	M_2		157	99		167		134
			c		1.4	2.1		1.6		1.6
			n_2 Eck		129	154		76		156
			n_2 th		94	113		76		98
29.931	330	0.67	M_2	55	178	112		189		153
			c	4.2	1.4	2.1		1.6		1.5
			n_2 Eck	132	114	135		67		137
			n_2 th	125	92	110		67		96
32.744	331	0.58	M_2	60	195	123		207		167
			c	3.9	1.3	1.9		1.4		1.4
			n_2 Eck	121	104	124		61		125
			n_2 th	116	85	102		61		88

$M \dots$ [Nm]
 $n \dots$ [min^{-1}]
 $J \dots$ [kgcm^2]

$P \dots$ [kW]
 $I \dots$ [A]
 i [-]
 c [-]

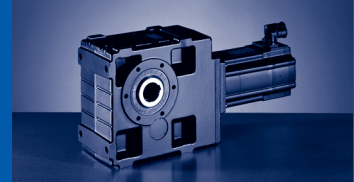

$M_{2GN} \leq 331 \text{ Nm}$

GKS05-3A				10IC40	13IC34	13IC41	14LC16	14LC20	14LC35	14LC41
				...S00	...F10	...S00	...F10	...S00	...F10	...S00
i	M_{2GN}	J_G	M_1	2	6.3	4	12	6.7	10.8	5.4
			n_1	3950	3410	4050	1635	2000	3455	4100
			I_{M400}	2.4	6	4.4	4.8	3.3	9.1	5.8
			P_N	0.8	2.2	1.7	2.1	1.4	3.9	2.3
			J_M	2.44	8.34	8.34	19.32	19.24	19.24	19.24
36.894	302	0.58	M_2	69	221	139		234		189
			c	3.1	1	1.6		1.2		1.1
			$n_{2 \text{ Eck}}$	107	92	110		54		111
			$n_{2 \text{ th}}$	100	69	82		54		72
41.765	331	0.42	M_2	78	250	158		265		214
			c	3	1	1.5		1.1		1.1
			$n_{2 \text{ Eck}}$	95	82	97		48		98
			$n_{2 \text{ th}}$	95	71	84		48		73
47.059	304	0.41	M_2	88		178		299		241
			c	2.8		1.4		1		1
			$n_{2 \text{ Eck}}$	84		86		43		87
			$n_{2 \text{ th}}$	84		72		43		63
51.162	331	0.32	M_2	95		194		326		262
			c	2.8		1.4		1		1
			$n_{2 \text{ Eck}}$	77		79		39		80
			$n_{2 \text{ th}}$	77		74		39		66
57.647	307	0.32	M_2	108		219				
			c	2.3		1.1				
			$n_{2 \text{ Eck}}$	69		70				
			$n_{2 \text{ th}}$	69		61				
66.592	331	0.2	M_2	125		253				
			c	2.2		1.1				
			$n_{2 \text{ Eck}}$	59		61				
			$n_{2 \text{ th}}$	59		61				
75.033	310	0.2	M_2	141						
			c	1.8						
			$n_{2 \text{ Eck}}$	53						
			$n_{2 \text{ th}}$	53						
82.833	331	0.14	M_2	156						
			c	1.7						
			$n_{2 \text{ Eck}}$	48						
			$n_{2 \text{ th}}$	48						
93.333	315	0.14	M_2	176						
			c	1.5						
			$n_{2 \text{ Eck}}$	42						
			$n_{2 \text{ th}}$	42						
107.196	331	0.09	M_2	203						
			c	1.3						
			$n_{2 \text{ Eck}}$	37						
			$n_{2 \text{ th}}$	37						
120.784	315	0.09	M_2	229						
			c	1.3						
			$n_{2 \text{ Eck}}$	33						
			$n_{2 \text{ th}}$	33						
130.097	331	0.07	M_2	247						
			c	1.2						
			$n_{2 \text{ Eck}}$	30						
			$n_{2 \text{ th}}$	30						
146.588	315	0.07	M_2	278						
			c	1						
			$n_{2 \text{ Eck}}$	27						
			$n_{2 \text{ th}}$	27						

$M \dots$ [Nm]
 $n \dots$ [min^{-1}]
 $J \dots$ [kgcm^2]

$P \dots$ [kW]
 $I \dots$ [A]
 i [-]
 c [-]

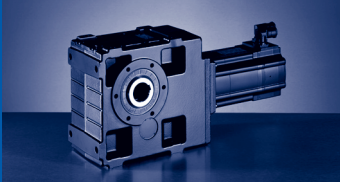

GKS [Nm]

GKS□□-□A (MCA)

$M_{2GN} \leq 283 \text{ Nm}$

GKS05-4A				10IC40
				...S00
i	M_{2GN}	J_G	M_1	
			n_1	2
			I_{M400}	3950
			P_N	2.4
			J_M	0.8
			M_2	2.44
			c	215
114.987	256	0.2	$n_{2 \text{ Eck}}$	1.1
			$n_{2 \text{ th}}$	34
			M_2	34
			c	34
126.933	283	0.2	$n_{2 \text{ Eck}}$	237
			$n_{2 \text{ th}}$	1.1
			c	31
				31

M ... [Nm]
 n ... [min^{-1}]
 J ... [kgcm^2]

P ... [kW]
 I ... [A]
 i [-]
 c [-]

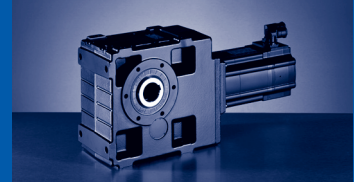

$M_{2GN} \leq 702 \text{ Nm}$

GKS06-3A				10IC40	13IC34	13IC41	14LC16	14LC20	14LC35	14LC41	17NC17	17NC23	17NC35	17NC41
				...S00	...F10	...S00	...F10	...S00	...F10	...S00	...F10	...S00	...F10	...S00
i	M_{2GN}	J_G	M_1	2	6.3	4	12	6.7	10.8	5.4	21.5	10.8	19	9.5
			n_1	3950	3410	4050	1635	2000	3455	4100	1680	2300	3480	4110
			I_{M400}	2.4	6	4.4	4.8	3.3	9.1	5.8	8.5	5.5	15.8	10.2
			P_N	0.8	2.2	1.7	2.1	1.4	3.9	2.3	3.8	2.6	6.9	4.1
			J_M	2.44	8.34	8.34	19.32	19.24	19.24	19.24	36.04	36.04	36.04	36.04
6.485	263	5.87	M_2				72	39	65	32	131	65	116	57
			c				3.5	5.8	3	5.7	1.9	3.4	1.7	3.2
			$n_{2 \text{ Eck}}$				252	308	533	632	259	355	537	634
			$n_{2 \text{ th}}$				252	308	354	404	259	355	294	359
9.196	373	5.05	M_2				102	56	92	45	186	92	165	81
			c				3.5	5.8	3	5.7	1.9	3.4	1.7	3.2
			$n_{2 \text{ Eck}}$				178	218	376	446	183	250	378	447
			$n_{2 \text{ th}}$				178	217	249	285	183	250	207	253
10.147	412	4.86	M_2				113	61	102	49	205	101	182	89
			c				3.5	5.8	3	5.7	1.9	3.4	1.7	3.2
			$n_{2 \text{ Eck}}$				161	197	341	404	166	227	343	405
			$n_{2 \text{ th}}$				161	197	226	258	166	227	188	230
11.382	331	2.49	M_2		66	41	128	70	115	57	232	115	205	101
			c		3.7	5.5	2.5	4.2	2.2	4.1	1.4	2.5	1.2	2.3
			$n_{2 \text{ Eck}}$		300	356	144	176	304	360	148	202	306	361
			$n_{2 \text{ th}}$		284	306	144	176	253	289	148	202	190	257
12.612	426	3.2	M_2				141	77	127	62	256	127	227	112
			c				2.9	4.8	2.5	4.7	1.6	2.9	1.4	2.7
			$n_{2 \text{ Eck}}$				130	159	274	325	133	182	276	326
			$n_{2 \text{ th}}$				130	159	203	232	133	182	160	207
14.824	600	4.29	M_2				165	90	149	72	300	148	266	131
			c				3.5	5.8	3	5.7	1.9	3.4	1.7	3.2
			$n_{2 \text{ Eck}}$				110	135	233	277	113	155	235	277
			$n_{2 \text{ th}}$				110	135	155	177	113	155	129	157
16.699	604	4.16	M_2				186	102	168	82	339	168	300	148
			c				3.1	5.2	2.7	5	1.7	3.1	1.5	2.9
			$n_{2 \text{ Eck}}$				98	120	207	246	101	138	208	246
			$n_{2 \text{ th}}$				98	120	134	153	101	138	107	136
17.809	518	2.13	M_2		104	64	200	110	180	88	362	180	321	158
			c		3.7	5.5	2.5	4.2	2.2	4.1	1.4	2.5	1.2	2.3
			$n_{2 \text{ Eck}}$		192	227	92	112	194	230	94	129	195	231
			$n_{2 \text{ th}}$		182	196	92	112	162	185	94	129	122	165
20.329	665	2.79	M_2				227	124	205	100	413	205	365	180
			c				2.8	4.7	2.4	4.6	1.5	2.8	1.4	2.6
			$n_{2 \text{ Eck}}$				80	98	170	202	83	113	171	202
			$n_{2 \text{ th}}$				80	98	125	143	83	113	98	127
22.902	606	2.73	M_2				258	141	233	114	466	232	413	204
			c				2.3	3.8	2	3.7	1.3	2.2	1.1	2.1
			$n_{2 \text{ Eck}}$				71	87	151	179	73	100	152	180
			$n_{2 \text{ th}}$				71	87	106	122	73	100	78	108
26.017	679	1.94	M_2		152	95	293	161	264	130	530	264	469	232
			c		3.3	4.9	2.2	3.7	1.9	3.6	1.2	2.2	1.1	2.1
			$n_{2 \text{ Eck}}$		131	156	63	77	133	158	65	88	134	158
			$n_{2 \text{ th}}$		122	131	63	77	107	124	65	88	79	110
28.461	682	1.67	M_2		167	104	321	177	290	142	580	289	514	254
			c		3.1	4.5	2	3.4	1.8	3.3	1.1	2	1	1.9
			$n_{2 \text{ Eck}}$		120	142	58	70	121	144	59	81	122	144
			$n_{2 \text{ th}}$		113	122	57	70	97	115	59	81	73	101
32.063	610	1.63	M_2		189	118	363	200	328	162		327		288
			c		2.4	3.6	1.6	2.7	1.4	2.7		1.6		1.5
			$n_{2 \text{ Eck}}$		106	126	51	62	108	128		72		128
			$n_{2 \text{ th}}$		96	104	51	62	76	98		72		79

$M \dots$ [Nm]
 $n \dots$ [min^{-1}]
 $J \dots$ [kgcm^2]

$P \dots$ [kW]
 $I \dots$ [A]
 i [-]
 c [-]

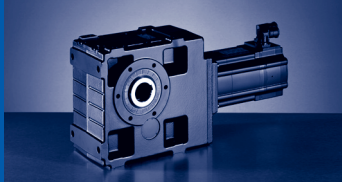

GKS [Nm]

GKS□□-□A (MCA)

$M_{2GN} \leq 702 \text{ Nm}$

GKS06-3A				10IC40	13IC34	13IC41	14LC16	14LC20	14LC35	14LC41	17NC17	17NC23	17NC35	17NC41
				...S00	...F10	...S00	...F10	...S00	...F10	...S00	...F10	...S00	...F10	...S00
i	M_{2GN}	J_G	M_1	2	6.3	4	12	6.7	10.8	5.4	21.5	10.8	19	9.5
			n_1	3950	3410	4050	1635	2000	3455	4100	1680	2300	3480	4110
			I_{M400}	2.4	6	4.4	4.8	3.3	9.1	5.8	8.5	5.5	15.8	10.2
			P_N	0.8	2.2	1.7	2.1	1.4	3.9	2.3	3.8	2.6	6.9	4.1
			J_M	2.44	8.34	8.34	19.32	19.24	19.24	19.24	36.04	36.04	36.04	36.04
36.303	685	1.18	M_2		214	134	411	227	371	183		370		326
			c		2.4	3.6	1.6	2.7	1.4	2.6		1.6		1.5
			$n_{2 \text{ Eck}}$		94	112	45	55	95	113		63		113
			$n_{2 \text{ th}}$		94	101	45	55	76	96		63		79
41.472	689	2.11	M_2				471	260	424	210		424		373
			c				1.4	2.4	1.2	2.3		1.4		1.3
			$n_{2 \text{ Eck}}$				39	48	83	99		56		99
			$n_{2 \text{ th}}$				39	48	45	61		49		47
44.471	689	0.9	M_2		263	165	505	279	455	225		454		400
			c		2.2	3.3	1.4	2.4	1.3	2.5		1.5		1.4
			$n_{2 \text{ Eck}}$		77	91	37	45	78	92		52		92
			$n_{2 \text{ th}}$		77	91	37	45	70	81		52		70
53.074	695	1.52	M_2		315	198	604	334	544	269		543		478
			c		1.9	2.8	1.2	2.1	1.1	2.1		1.3		1.2
			$n_{2 \text{ Eck}}$		64	76	31	38	65	77		43		77
			$n_{2 \text{ th}}$		52	58	31	38	39	54		41		40
57.882	695	0.58	M_2	105	344	216	659	365	594	294				
			c	5.2	1.7	2.6	1.1	1.9	1	1.9				
			$n_{2 \text{ Eck}}$	68	59	70	28	35	60	71				
			$n_{2 \text{ th}}$	68	59	70	28	35	58	62				
65.207	624	0.57	M_2	120	389	245		413		333				
			c	4.2	1.4	2.1		1.5		1.5				
			$n_{2 \text{ Eck}}$	61	52	62		31		63				
			$n_{2 \text{ th}}$	61	52	62		31		55				
72	702	0.42	M_2	132	429	270		456		367				
			c	4.2	1.4	2.1		1.5		1.6				
			$n_{2 \text{ Eck}}$	55	47	56		28		57				
			$n_{2 \text{ th}}$	55	47	56		28		50				
81.111	630	0.42	M_2	150	485	306		515		415				
			c	3.4	1.1	1.7		1.2		1.2				
			$n_{2 \text{ Eck}}$	49	42	50		25		51				
			$n_{2 \text{ th}}$	49	42	50		25		44				
93.176	702	0.26	M_2	173	557	352								
			c	3.3	1.1	1.6								
			$n_{2 \text{ Eck}}$	42	37	44								
			$n_{2 \text{ th}}$	42	37	43								
104.967	635	0.25	M_2	196		398								
			c	2.6		1.3								
			$n_{2 \text{ Eck}}$	38		39								
			$n_{2 \text{ th}}$	38		39								
113.082	702	0.19	M_2	210		427								
			c	3		1.5								
			$n_{2 \text{ Eck}}$	35		36								
			$n_{2 \text{ th}}$	35		36								
127.392	635	0.19	M_2	238		483								
			c	2.4		1.2								
			$n_{2 \text{ Eck}}$	31		32								
			$n_{2 \text{ th}}$	31		32								
142.941	702	0.12	M_2	268										
			c	2.4										
			$n_{2 \text{ Eck}}$	28										
			$n_{2 \text{ th}}$	28										

$M \dots$ [Nm]
 $n \dots$ [min^{-1}]
 $J \dots$ [kgcm^2]

$P \dots$ [kW]
 $I \dots$ [A]
 i [-]
 c [-]

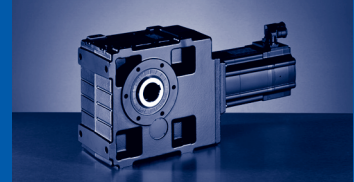

$M_{2GN} \leq 702 \text{ Nm}$

GKS06-3A				10IC40	13IC34	13IC41	14LC16	14LC20	14LC35	14LC41	17NC17	17NC23	17NC35	17NC41		
				...S00	...F10	...S00	...F10	...S00	...F10	...S00	...F10	...S00	...F10	...S00		
i	M_{2GN}	J_G	M_1	2	6.3	4	12	6.7	10.8	5.4	21.5	10.8	19	9.5		
			n_1	3950	3410	4050	1635	2000	3455	4100	1680	2300	3480	4110		
			I_{M400}	2.4	6	4.4	4.8	3.3	9.1	5.8	8.5	5.5	15.8	10.2		
			P_N	0.8	2.2	1.7	2.1	1.4	3.9	2.3	3.8	2.6	6.9	4.1		
			J_M	2.44	8.34	8.34	19.32	19.24	19.24	19.24	36.04	36.04	36.04	36.04		
161.029	635	0.12	M_2	303												
			c	1.9												
			$n_{2 \text{ Eck}}$	25												
			$n_{2 \text{ th}}$	25												
190.08	702	0.23	M_2	358												
			c	1.8												
			$n_{2 \text{ Eck}}$	21												
			$n_{2 \text{ th}}$	21												
214.133	635	0.23	M_2	405												
			c	1.4												
			$n_{2 \text{ Eck}}$	19												
			$n_{2 \text{ th}}$	18												
230.688	702	0.17	M_2	436												
			c	1.5												
			$n_{2 \text{ Eck}}$	17												
			$n_{2 \text{ th}}$	17												
259.88	635	0.17	M_2	493												
			c	1.2												
			$n_{2 \text{ Eck}}$	15												
			$n_{2 \text{ th}}$	15												
291.6	702	0.11	M_2	553												
			c	1.2												
			$n_{2 \text{ Eck}}$	14												
			$n_{2 \text{ th}}$	14												

M ... [Nm]
n ... [min^{-1}]
J ... [kgcm^2]

P ... [kW]
I ... [A]
i [-]
c [-]

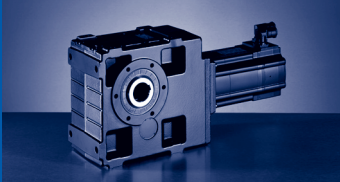

GKS [Nm]

GKS□□-□A (MCA)

$M_{2GN} \leq 702 \text{ Nm}$

GKS06-4A				10IC40	13IC41
				...500	...500
i	M_{2GN}	J_G	M_1		
			n_1	2	4
			I_{M400}	3950	4050
			P_N	2.4	4.4
			J_M	0.8	1.7
			M_2	2.44	8.34
103.721	685	0.3	c	190	386
			$n_2 \text{ Eck}$	2.9	1.4
			$n_2 \text{ th}$	38	39
			M_2	38	39
113.205	537	0.23	c	208	422
			$n_2 \text{ Eck}$	2.3	1.2
			$n_2 \text{ th}$	35	36
			M_2	35	36
127.059	689	0.26	c	233	473
			$n_2 \text{ Eck}$	2.7	1.3
			$n_2 \text{ th}$	31	32
			M_2	31	32
140.816	537	0.21	c	261	
			$n_2 \text{ Eck}$	1.9	
			$n_2 \text{ th}$	28	
			M_2	28	
155.647	689	0.19	c	287	581
			$n_2 \text{ Eck}$	2.2	1.1
			$n_2 \text{ th}$	25	26
			M_2	25	26
174.336	537	0.11	c	324	
			$n_2 \text{ Eck}$	1.5	
			$n_2 \text{ th}$	23	
			M_2	23	
202.588	695	0.17	c	376	
			$n_2 \text{ Eck}$	1.7	
			$n_2 \text{ th}$	20	
			M_2	20	
224.524	537	0.07	c	419	
			$n_2 \text{ Eck}$	1.2	
			$n_2 \text{ th}$	18	
			M_2	18	
252	702	0.16	c	469	
			$n_2 \text{ Eck}$	1.4	
			$n_2 \text{ th}$	16	
			M_2	16	
316.8	702	0.1	c	591	
			$n_2 \text{ Eck}$	1.1	
			$n_2 \text{ th}$	13	
			M_2	12	

M ... [Nm]
 n ... [min^{-1}]
 J ... [kgcm^2]

P ... [kW]
 I ... [A]
 i [-]
 c [-]

GKS [Nm]
GKS□□-□A (MCA)

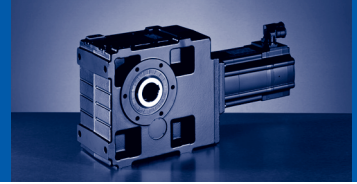

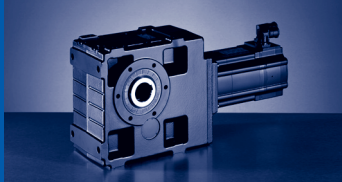

GKS [Nm]

GKS□□-□A (MCA)

$M_{2GN} \leq 1330 \text{ Nm}$

GKS07-3A				10IC40	13IC34	13IC41	14LC16	14LC20	14LC35	14LC41	17NC17	17NC23	
				...S00	...F10	...S00	...F10	...S00	...F10	...S00	...F10	...S00	
i	M_{2GN}	J_G	M_1	2	6.3	4	12	6.7	10.8	5.4	21.5	10.8	
			n_1	3950	3410	4050	1635	2000	3455	4100	1680	2300	
			I_{M400}	2.4	6	4.4	4.8	3.3	9.1	5.8	8.5	5.5	
			P_N	0.8	2.2	1.7	2.1	1.4	3.9	2.3	3.8	2.6	
			J_M	2.44	8.34	8.34	19.32	19.24	19.24	19.24	36.04	36.04	
5.955	471	19.3	M_2								118		
			c								3.7		
			n_2 Eck									282	
			n_2 th									282	
8.254	541	11.8	M_2								165	81	
			c								3.1	5.5	
			n_2 Eck									204	279
			n_2 th									204	279
9.171	725	16	M_2								182		
			c								3.7		
			n_2 Eck									183	
			n_2 th									183	
10.124	800	15.88	M_2								201		
			c								3.7		
			n_2 Eck									166	
			n_2 th									166	
11.378	613	7.02	M_2				125		113		229	112	
			c				4.6		4		2.5	4.6	
			n_2 Eck				144		304		148	202	
			n_2 th				144		248		148	202	
12.711	832	10.16	M_2								254	124	
			c								3.1	5.5	
			n_2 Eck								132	181	
			n_2 th								132	181	
14.798	1040	14.31	M_2								295	144	
			c								3.3	5.9	
			n_2 Eck								114	155	
			n_2 th								114	153	
16.674	1071	13.97	M_2								333	163	
			c								3	5.4	
			n_2 Eck								101	138	
			n_2 th								101	134	
17.27	998	7.26	M_2				189		171		346	170	
			c				4.9		4.3		2.7	4.9	
			n_2 Eck				95		200		97	133	
			n_2 th				95		159		97	133	
20.511	1110	9.08	M_2								412	202	
			c								2.6	4.6	
			n_2 Eck								82	112	
			n_2 th								82	112	
23.111	1168	8.91	M_2								465	229	
			c								2.4	4.3	
			n_2 Eck								73	100	
			n_2 th								73	100	
25.244	1177	6.72	M_2				279		252		509	251	
			c				4		3.4		2.2	3.9	
			n_2 Eck				65		137		67	91	
			n_2 th				65		104		67	91	
28.274	1202	5.57	M_2				313		284	137	571	282	
			c				3.6		3.1	5.9	2	3.6	
			n_2 Eck				58		122	145	59	81	
			n_2 th				58		95	108	59	81	

M ... [Nm]
 n ... [min⁻¹]
 J ... [kgcm²]

P ... [kW]
 I ... [A]
 i [-]
 c [-]

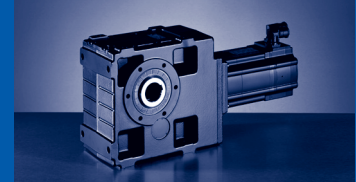

$M_{2GN} \leq 1330 \text{ Nm}$

17NC35	17NC41	19SC17	19SC23	19SC35	19SC42	21XC17	21XC25	21XC35	21XC42	GKS07-3A			
...F10	...S00	...F10	...S00	...F10	...S00	...F10	...S00	...F10	...S00	M_1	J_G	M_{2GN}	i
19	9.5	36.3	16.3	36	12	61.4	24.6	55	17	n_1			
3480	4110	1700	2340	3510	4150	1710	2490	3520	4160	I_{M400}			
15.8	10.2	13.9	8.2	28.7	14	22.5	13.5	42.5	19.8	P_N			
6.9	4.1	6.4	4	13.2	5.2	11	6.4	20.3	7.4	J_M			
36.04	36.04	72.12	72.12	72.04	72.12	180.04	180.04	180.04	180.04	M_2			
105		203	89	202	65	346	136	311	94	c			
3.3		2.2	4.4	1.7	4.9	1.3	2.9	1.1	3.5	n_{2Eck}	19.3	471	5.955
584		286	393	589	697	287	418	591	699	n_{2th}			
335		285	357	273	367	230	323	215	338	M_2			
146	71	282	124	281	91	481	190		131	c			
2.7	5.2	1.8	3.7	1.4	4.1	1.1	2.4		2.9	n_{2Eck}	11.8	541	8.254
422	498	206	284	425	503	207	302		504	n_{2th}			
268	307	206	284	206	292	178	244		244	M_2			
161		312	137	311	100	533	210	478	144	c			
3.3		2.2	4.4	1.7	4.9	1.3	2.9	1.1	3.5	n_{2Eck}	16	725	9.171
380		185	255	383	453	187	272	384	454	n_{2th}			
217		185	232	177	238	150	210	140	220	M_2			
178		345	151	343	111	589	232	528	159	c			
3.3		2.2	4.4	1.7	4.9	1.3	2.9	1.1	3.5	n_{2Eck}	15.88	800	10.124
344		168	231	347	410	169	246	348	411	n_{2th}			
197		168	210	160	216	135	190	127	199	M_2			
203	99	390	172	388	126		263		181	c			
2.3	4.3	1.5	3	1.2	3.4		2		2.4	n_{2Eck}	7.02	613	11.378
306	361	149	206	309	365		219		366	n_{2th}			
220	252	149	206	162	215		177		177	M_2			
225	110	434	191	433	140	741	293		201	c			
2.7	5.2	1.8	3.7	1.4	4.1	1.1	2.4		2.9	n_{2Eck}	10.16	832	12.711
274	323	134	184	276	327	135	196		327	n_{2th}			
174	199	134	184	134	190	116	158		158	M_2			
262	127	505	222	503	163	862	340	773	234	c			
2.9	5.6	2	3.9	1.6	4.4	1.2	2.5	1	3.1	n_{2Eck}	14.31	1040	14.798
235	278	115	158	237	280	116	168	238	281	n_{2th}			
131	151	115	140	102	144	87	126	82	133	M_2			
296	144	570	251	568	184	972	384		264	c			
2.7	5.1	1.8	3.6	1.4	4	1.1	2.3		2.8	n_{2Eck}	13.97	1071	16.674
209	247	102	140	211	249	103	149		250	n_{2th}			
114	132	99	122	86	125	74	110		115	M_2			
307	150	592	261	589	191		399		274	c			
2.4	4.6	1.6	3.2	1.3	3.6		2.1		2.6	n_{2Eck}	7.26	998	17.27
202	238	98	136	203	240		144		241	n_{2th}			
141	162	98	136	104	142		117		117	M_2			
365	179	703	311	700	228		474		326	c			
2.3	4.3	1.5	3	1.2	3.4		2		2.4	n_{2Eck}	9.08	1110	20.511
170	200	83	114	171	202		121		203	n_{2th}			
103	119	83	110	75	113		98		98	M_2			
412	202	793	351	789	257		535		368	c			
2.1	4	1.4	2.8	1.1	3.2		1.8		2.2	n_{2Eck}	8.91	1168	23.111
151	178	74	101	152	180		108		180	n_{2th}			
90	104	73	96	65	99		84		87	M_2			
451	221	868	384	863	282		586		403	c			
2	3.7	1.3	2.6	1	2.9		1.7		1.7	n_{2Eck}	6.72	1177	25.244
138	163	67	93	139	164		99		165	n_{2th}			
91	106	67	93	64	97		80		80	M_2			
506	249	973	431		317		657		452	c			
1.8	3.4	1.2	2.4		2.7		1.5		1.9	n_{2Eck}	5.57	1202	28.274
123	145	60	83		147		88		147	n_{2th}			
81	97	60	83		87		71		71				

M ... [Nm]
n ... [min⁻¹]
J ... [kgcm²]

P ... [kW]
I ... [A]
i [-]
c [-]

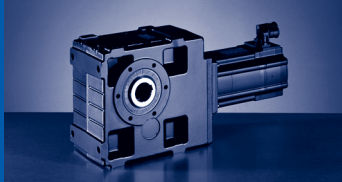

GKS [Nm]

GKS□□-□A (MCA)

$M_{2GN} \leq 1330 \text{ Nm}$

GKS07-3A				10IC40	13IC34	13IC41	14LC16	14LC20	14LC35	14LC41	17NC17	17NC23
				...S00	...F10	...S00	...F10	...S00	...F10	...S00	...F10	...S00
i	M_{2GN}	J_G	M_1	2	6.3	4	12	6.7	10.8	5.4	21.5	10.8
			n_1	3950	3410	4050	1635	2000	3455	4100	1680	2300
			I_{M400}	2.4	6	4.4	4.8	3.3	9.1	5.8	8.5	5.5
			P_N	0.8	2.2	1.7	2.1	1.4	3.9	2.3	3.8	2.6
			J_M	2.44	8.34	8.34	19.32	19.24	19.24	19.24	36.04	36.04
31.858	1172	5.47	M_2				355	194	321	156	646	320
			c				3.1	5.3	2.7	5.1	1.7	3.1
			$n_{2 \text{ Eck}}$				51	63	109	129	53	72
			$n_{2 \text{ th}}$				51	63	82	93	53	72
36.063	1290	3.65	M_2		208		402	220	364	177	731	362
			c		4.6		3.1	5.1	2.6	5	1.7	3
			$n_{2 \text{ Eck}}$		95		45	56	96	114	47	64
			$n_{2 \text{ th}}$		94		45	55	84	96	47	64
40.906	1290	6.93	M_2								831	412
			c								1.5	2.7
			$n_{2 \text{ Eck}}$								41	56
			$n_{2 \text{ th}}$								41	54
44.178	1300	2.78	M_2				495	270	446	218	898	444
			c				2.6	4.6	2.5	4.7	1.4	2.8
			$n_{2 \text{ Eck}}$				37	45	78	93	38	52
			$n_{2 \text{ th}}$				37	45	74	81	38	52
50.345	1300	5.3	M_2				566	310	510	250	1025	508
			c				2.3	4.1	2.2	4.1	1.3	2.5
			$n_{2 \text{ Eck}}$				33	40	69	81	33	46
			$n_{2 \text{ th}}$				32	40	47	54	33	46
57.501	1310	1.75	M_2		336	210	649	356	584	287	1173	582
			c		3.3	4.9	2	3.6	1.9	3.6	1.1	2.2
			$n_{2 \text{ Eck}}$		59	70	28	35	60	71	29	40
			$n_{2 \text{ th}}$		59	70	28	35	60	62	29	40
64.79	1195	1.73	M_2		381	238	734	404	661	326		659
			c		2.7	4	1.6	2.9	1.6	2.9		1.8
			$n_{2 \text{ Eck}}$		53	63	25	31	53	63		36
			$n_{2 \text{ th}}$		53	63	25	31	52	55		36
70.474	1320	1.3	M_2		414	259	798	439	719	354		717
			c		2.7	4	1.6	2.9	1.6	3		1.8
			$n_{2 \text{ Eck}}$		48	58	23	28	49	58		33
			$n_{2 \text{ th}}$		48	57	23	28	49	51		33
79.407	1205	1.28	M_2		469	295	902	498	812	401		811
			c		2.2	3.3	1.3	2.4	1.3	2.4		1.5
			$n_{2 \text{ Eck}}$		43	51	21	25	44	52		29
			$n_{2 \text{ th}}$		43	51	21	25	44	45		29
92.563	1330	0.81	M_2		548	344	1052	581	948	468		
			c		2.1	3.1	1.3	2.3	1.2	2.3		
			$n_{2 \text{ Eck}}$		37	44	18	22	37	44		
			$n_{2 \text{ th}}$		37	44	18	22	37	39		
104.296	1215	0.8	M_2	190	620	390	1189	658		530		
			c	5.1	1.7	2.5	1	1.8		1.9		
			$n_{2 \text{ Eck}}$	38	33	39	16	19		39		
			$n_{2 \text{ th}}$	38	33	39	16	19		34		
112.338	1330	0.59	M_2	203	666	419	1280	708	1151	570		
			c	5.7	1.9	2.8	1	1.9	1.1	2.1		
			$n_{2 \text{ Eck}}$	35	30	36	15	18	31	37		
			$n_{2 \text{ th}}$	35	30	36	15	18	31	32		
126.578	1215	0.59	M_2	231	753	474		801		645		
			c	4.6	1.5	2.3		1.5		1.7		
			$n_{2 \text{ Eck}}$	31	27	32		16		32		
			$n_{2 \text{ th}}$	31	27	32		16		28		

$M \dots$ [Nm]
 $n \dots$ [min^{-1}]
 $J \dots$ [kgcm^2]

$P \dots$ [kW]
 $I \dots$ [A]
 $i \dots$ [-]
 $c \dots$ [-]

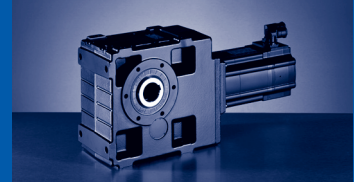

$M_{2GN} \leq 1330 \text{ Nm}$

17NC35	17NC41	19SC17	19SC23	19SC35	19SC42	21XC17	21XC25	21XC35	21XC42	GKS07-3A			
...F10	...S00	...F10	...S00	...F10	...S00	...F10	...S00	...F10	...S00				
19	9.5	36.3	16.3	36	12	61.4	24.6	55	17	M_1	J_G	M_{2GN}	i
3480	4110	1700	2340	3510	4150	1710	2490	3520	4160	n_1			
15.8	10.2	13.9	8.2	28.7	14	22.5	13.5	42.5	19.8	I_{M400}			
6.9	4.1	6.4	4	13.2	5.2	11	6.4	20.3	7.4	P_N			
36.04	36.04	72.12	72.12	72.04	72.12	180.04	180.04	180.04	180.04	J_M			
572	282	1098	488		358		742		511	M_2			
1.5	2.9	1	2.1		2.3		1.3		1.6	c	5.47	1172	31.858
109	129	53	74		130		78		131	n_{2Eck}			
66	83	53	73		77		61		63	n_{2th}			
647	319		553		406					M_2			
1.5	2.8		2		2.2					c	3.65	1290	36.063
97	114		65		115					n_{2Eck}			
67	86		65		68					n_{2th}			
736	363		628		461		954		658	M_2			
1.3	2.5		1.8		2		1.1		1.4	c	6.93	1290	40.906
85	101		57		102		61		102	n_{2Eck}			
40	53		47		50		37		41	n_{2th}			
794	392		678		498					M_2			
1.4	2.7		1.9		2.1					c	2.78	1300	44.178
79	93		53		94					n_{2Eck}			
60	70		53		55					n_{2th}			
906	448		774		569		1176		810	M_2			
1.2	2.3		1.6		1.8		1.1		1.3	c	5.3	1300	50.345
69	82		47		82		50		83	n_{2Eck}			
35	48		41		44		33		36	n_{2th}			
1037	513									M_2			
1.1	2.1									c	1.75	1310	57.501
61	72									n_{2Eck}			
49	54									n_{2th}			
	581									M_2			
	1.7									c	1.73	1195	64.79
	63									n_{2Eck}			
	48									n_{2th}			
	631									M_2			
	1.7									c	1.3	1320	70.474
	58									n_{2Eck}			
	44									n_{2th}			
	714									M_2			
	1.4									c	1.28	1205	79.407
	52									n_{2Eck}			
	39									n_{2th}			
										M_2			
										c	0.81	1330	92.563
										n_{2Eck}			
										n_{2th}			
										M_2			
										c	0.8	1215	104.296
										n_{2Eck}			
										n_{2th}			
										M_2			
										c	0.59	1330	112.338
										n_{2Eck}			
										n_{2th}			
										M_2			
										c	0.59	1215	126.578
										n_{2Eck}			
										n_{2th}			

M ... [Nm]
n ... [min⁻¹]
J ... [kgcm²]

P ... [kW]
I ... [A]
i [-]
c [-]

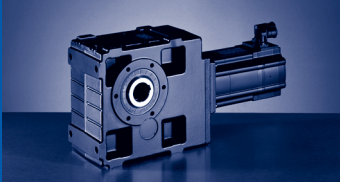

GKS [Nm]

GKS□□-□A (MCA)

$M_{2GN} \leq 1330 \text{ Nm}$

GKS07-3A				10IC40	13IC34	13IC41	14LC16	14LC20	14LC35	14LC41	17NC17	17NC23
				...S00	...F10	...S00	...F10	...S00	...F10	...S00	...F10	...S00
i	M_{2GN}	J_G	M_1	2	6.3	4	12	6.7	10.8	5.4	21.5	10.8
			n_1	3950	3410	4050	1635	2000	3455	4100	1680	2300
			I_{M400}	2.4	6	4.4	4.8	3.3	9.1	5.8	8.5	5.5
			P_N	0.8	2.2	1.7	2.1	1.4	3.9	2.3	3.8	2.6
			J_M	2.44	8.34	8.34	19.32	19.24	19.24	19.24	36.04	36.04
140.548	1330	1.11	M_2		836	527		890		716		
			c		1.5	2.3		1.5		1.7		
			$n_{2 \text{ Eck}}$		24	29		14		29		
			$n_{2 \text{ th}}$		24	29		14		26		
158.364	1215	1.11	M_2		945	596		1006		809		
			c		1.2	1.8		1.2		1.4		
			$n_{2 \text{ Eck}}$		22	26		13		26		
			$n_{2 \text{ th}}$		22	26		13		23		
184.6	1330	0.69	M_2	342	1103	696		1173		944		
			c	3.5	1.2	1.7		1.1		1.3		
			$n_{2 \text{ Eck}}$	21	19	22		11		22		
			$n_{2 \text{ th}}$	21	18	22		11		19		
208	1215	0.69	M_2	388		787				1067		
			c	2.8		1.4				1		
			$n_{2 \text{ Eck}}$	19		20				20		
			$n_{2 \text{ th}}$	19		19				17		
224.037	1330	0.51	M_2	417		848				1149		
			c	2.9		1.4				1		
			$n_{2 \text{ Eck}}$	18		18				18		
			$n_{2 \text{ th}}$	18		18				16		
252.436	1215	0.51	M_2	473		958						
			c	2.3		1.2						
			$n_{2 \text{ Eck}}$	16		16						
			$n_{2 \text{ th}}$	16		16						
283.193	1330	0.33	M_2	531		1075						
			c	2.3		1.1						
			$n_{2 \text{ Eck}}$	14		14						
			$n_{2 \text{ th}}$	14		14						
319.091	1215	0.33	M_2	601								
			c	1.8								
			$n_{2 \text{ Eck}}$	12								
			$n_{2 \text{ th}}$	12								

$M \dots$ [Nm]
 $n \dots$ [min^{-1}]
 $J \dots$ [kgcm^2]

$P \dots$ [kW]
 $I \dots$ [A]
 $i \dots$ [-]
 $c \dots$ [-]

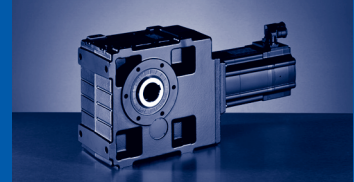

$M_{2GN} \leq 1330 \text{ Nm}$

17NC35	17NC41	19SC17	19SC23	19SC35	19SC42	21XC17	21XC25	21XC35	21XC42	GKS07-3A			
...F10	...S00	...F10	...S00	...F10	...S00	...F10	...S00	...F10	...S00	M_1	J_G	M_{2GN}	i
19	9.5	36.3	16.3	36	12	61.4	24.6	55	17	n_1			
3480	4110	1700	2340	3510	4150	1710	2490	3520	4160	I_{M400}			
15.8	10.2	13.9	8.2	28.7	14	22.5	13.5	42.5	19.8	P_N			
6.9	4.1	6.4	4	13.2	5.2	11	6.4	20.3	7.4	J_M			
36.04	36.04	72.12	72.12	72.04	72.12	180.04	180.04	180.04	180.04	M_2 c n_2 Eck n_2 th	1.11	1330	140.548
										M_2 c n_2 Eck n_2 th	1.11	1215	158.364
										M_2 c n_2 Eck n_2 th	0.69	1330	184.6
										M_2 c n_2 Eck n_2 th	0.69	1215	208
										M_2 c n_2 Eck n_2 th	0.51	1330	224.037
										M_2 c n_2 Eck n_2 th	0.51	1215	252.436
										M_2 c n_2 Eck n_2 th	0.33	1330	283.193
										M_2 c n_2 Eck n_2 th	0.33	1215	319.091

M ... [Nm]
n ... [min⁻¹]
J ... [kgcm²]

P ... [kW]
I ... [A]
i [-]
c [-]

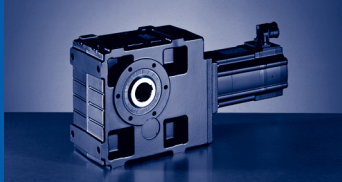

GKS [Nm]

GKS□□-□A (MCA)

$M_{2GN} \leq 1330 \text{ Nm}$

GKS07-4A				10IC40	13IC34	13IC41	14LC16	14LC20	14LC35	14LC41
				...500	...F10	...500	...F10	...500	...F10	...500
i	M_{2GN}	J_G	M_1							
			n_1	2	6.3	4	12	6.7	10.8	5.4
			I_{M400}	3950	3410	4050	1635	2000	3455	4100
			P_N	2.4	6	4.4	4.8	3.3	9.1	5.8
			J_M	0.8	2.2	1.7	2.1	1.4	3.9	2.3
			M_2	2.44	8.34	8.34	19.32	19.24	19.24	19.24
			c	183	601	378	1153	638	1038	514
103.039	1290	0.84	$n_2 \text{ Eck}$	5.5	1.8	2.7	1.1	2	1.1	2
			$n_2 \text{ th}$	38	33	39	16	19	34	40
				38	33	39	16	19	34	35
			M_2	202	657	414		699		563
			c	4.6	1.5	2.3		1.5		1.7
112.391	1053	0.63	$n_2 \text{ Eck}$	35	30	36		18		37
			$n_2 \text{ th}$	35	30	36		18		32
			M_2	226	737	464		784		631
			c	5	1.7	2.5		1.7		1.8
126.222	1300	0.73	$n_2 \text{ Eck}$	31	27	32		16		33
			$n_2 \text{ th}$	31	27	32		16		28
			M_2	250	808	510		860		692
			c	3.7	1.3	1.9		1.2		1.4
137.748	1053	0.57	$n_2 \text{ Eck}$	29	25	29		15		30
			$n_2 \text{ th}$	29	25	29		15		26
			M_2	279	906	571		964		775
			c	4.1	1.4	2		1.3		1.5
154.622	1300	0.53	$n_2 \text{ Eck}$	26	22	26		13		27
			$n_2 \text{ th}$	26	22	26		13		23
			M_2	328		666				
			c	2.9		1.4				
179.201	1053	0.28	$n_2 \text{ Eck}$	22		23				
			$n_2 \text{ th}$	22		23				
			M_2	367	1183	747		1258		1013
			c	3.2	1.1	1.6		1		1.2
201.254	1310	0.45	$n_2 \text{ Eck}$	20	17	20		10		20
			$n_2 \text{ th}$	20	17	20		10		18
			M_2	410		831				
			c	2.3		1.2				
222.909	1053	0.2	$n_2 \text{ Eck}$	18		18				
			$n_2 \text{ th}$	18		18				
			M_2	453		918				
			c	2.6		1.3				
246.659	1320	0.42	$n_2 \text{ Eck}$	16		16				
			$n_2 \text{ th}$	16		16				
			M_2	505						
			c	1.9						
273.199	1053	0.18	$n_2 \text{ Eck}$	15						
			$n_2 \text{ th}$	14						
			M_2	593						
			c	2						
321.049	1320	0.26	$n_2 \text{ Eck}$	12						
			$n_2 \text{ th}$	12						
			M_2	667						
			c	1.4						
358.829	1053	0.17	$n_2 \text{ Eck}$	11						
			$n_2 \text{ th}$	11						
			M_2	741						
			c	1.6						
399.353	1320	0.18	$n_2 \text{ Eck}$	10						
			$n_2 \text{ th}$	10						

M ... [Nm]
 n ... [min⁻¹]
 J ... [kgcm²]

P ... [kW]
 I ... [A]
 i [-]
 c [-]

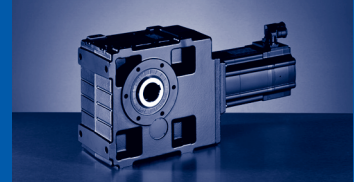

$M_{2GN} \leq 1330 \text{ Nm}$

GKS07-4A				10IC40	13IC34	13IC41	14LC16	14LC20	14LC35	14LC41
				...S00	...F10	...S00	...F10	...S00	...F10	...S00
i	M_{2GN}	J_G	M_1							
			n_1	2	6.3	4	12	6.7	10.8	5.4
			I_{M400}	3950	3410	4050	1635	2000	3455	4100
			P_N	2.4	6	4.4	4.8	3.3	9.1	5.8
			J_M	0.8	2.2	1.7	2.1	1.4	3.9	2.3
			M_2	2.44	8.34	8.34	19.32	19.24	19.24	19.24
			c	866						
464.367	1053	0.11	$n_{2 \text{ Eck}}$	1.1						
			$n_{2 \text{ th}}$	9						
			M_2	963						
			c	1.3						
516.81	1320	0.11	$n_{2 \text{ Eck}}$	8						
			$n_{2 \text{ th}}$	8						
			M_2	1189						
			c	1						
636.581	1330	0.16	$n_{2 \text{ Eck}}$	6						
			$n_{2 \text{ th}}$	6						

M ... [Nm]
n ... [min^{-1}]
J ... [kgcm^2]

P ... [kW]
I ... [A]
i [-]
c [-]

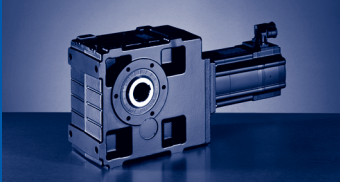

GKS [Nm]

GKS□□-□A (MCA)

$M_{2GN} \leq 3080 \text{ Nm}$

GKS09-3A				14LC16	14LC20	14LC35	14LC41	17NC17	17NC23	17NC35	17NC41
				...F10	...S00	...F10	...S00	...F10	...S00	...F10	...S00
i	M_{2GN}	J_G	M_1	12	6.7	10.8	5.4	21.5	10.8	19	9.5
			n_1	1635	2000	3455	4100	1680	2300	3480	4110
			I_{M400}	4.8	3.3	9.1	5.8	8.5	5.5	15.8	10.2
			P_N	2.1	1.4	3.9	2.3	3.8	2.6	6.9	4.1
			J_M	19.32	19.24	19.24	19.24	36.04	36.04	36.04	36.04
12.283	1615	34.2	M_2								
			c								
			n_2 Eck								
			n_2 th								
13.36	1757	33.4	M_2								
			c								
			n_2 Eck								
			n_2 th								
16.122	1801	22.6	M_2					314		280	
			c					5.3		4.7	
			n_2 Eck					104		216	
			n_2 th					104		141	
17.536	1958	22.2	M_2					342		304	
			c					5.3		4.7	
			n_2 Eck					96		199	
			n_2 th					96		129	
19.541	2570	30.6	M_2								
			c								
			n_2 Eck								
			n_2 th								
22.022	2672	29.9	M_2								
			c								
			n_2 Eck								
			n_2 th								
25.649	2862	20.5	M_2					500		445	
			c					5.3		4.7	
			n_2 Eck					66		136	
			n_2 th					66		88	
29.228	2914	15.9	M_2					574		510	
			c					4.7		4.2	
			n_2 Eck					58		119	
			n_2 th					57		83	
32.94	2984	15.6	M_2					650		577	
			c					4.3		3.8	
			n_2 Eck					51		106	
			n_2 th					51		72	
35.193	2670	12.2	M_2			344					
			c			5.6					
			n_2 Eck			98					
			n_2 th			83					
35.193	3029	12.2	M_2					696		618	
			c					4.1		3.6	
			n_2 Eck					48		99	
			n_2 th					48		75	
39.662	3002	12	M_2			387		788		699	339
			c			5.6		3.6		3.2	6
			n_2 Eck			87		42		88	104
			n_2 th			73		42		65	74
43.146	3024	9	M_2					859		760	
			c					3.4		3.3	
			n_2 Eck					39		81	
			n_2 th					39		66	

$M \dots$ [Nm]
 $n \dots$ [min^{-1}]
 $J \dots$ [kgcm^2]

$P \dots$ [kW]
 $I \dots$ [A]
 i [-]
 c [-]

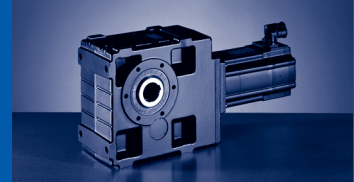

$M_{2GN} \leq 3080 \text{ Nm}$

195C17	195C23	195C35	195C42	21XC17	21XC25	21XC35	21XC42	GKS09-3A			
...F10	...S00	...F10	...S00	...F10	...S00	...F10	...S00	M_1	J_G	M_{2GN}	i
36.3	16.3	36	12	61.4	24.6	55	17	n_1			
1700	2340	3510	4150	1710	2490	3520	4160	I_{M400}			
13.9	8.2	28.7	14	22.5	13.5	42.5	19.8	P_N			
6.4	4	13.2	5.2	11	6.4	20.3	7.4	J_M			
72.12	72.12	72.04	72.12	180.04	180.04	180.04	180.04	M_2			
412		412		708	276	636	188	c			
3.7		2.9		2.2	4.8	1.9	5.8	$n_{2\text{Eck}}$	34.2	1615	12.283
138		286		139	203	287	339	$n_{2\text{th}}$			
138		146		135	163	129	164				
448		448		770	300	691	205	M_2			
3.7		2.9		2.2	4.8	1.9	5.8	c	33.4	1757	13.36
127		263		128	186	264	311	$n_{2\text{Eck}}$			
127		134		124	150	119	151	$n_{2\text{th}}$			
544		543		932	365	837	250	M_2			
3.1		2.5		1.8	4	1.6	4.9	c	22.6	1801	16.122
105		218		106	154	218	258	$n_{2\text{Eck}}$			
105		122		106	125	103	125	$n_{2\text{th}}$			
591		590		1014	397	910	271	M_2			
3.1		2.5		1.8	4	1.6	4.9	c	22.2	1958	17.536
97		200		98	142	201	237	$n_{2\text{Eck}}$			
97		112		98	115	95	115	$n_{2\text{th}}$			
655		655		1126	439	1011	300	M_2			
3.7		2.9		2.2	4.8	1.9	5.8	c	30.6	2570	19.541
87		180		88	127	180	213	$n_{2\text{Eck}}$			
87		91		85	102	81	103	$n_{2\text{th}}$			
740		740		1271	496	1141	339	M_2			
3.4		2.7		2	4.4	1.8	5.4	c	29.9	2672	22.022
77		159		78	113	160	189	$n_{2\text{Eck}}$			
77		80		74	89	69	91	$n_{2\text{th}}$			
865		864		1483	580	1331	397	M_2			
3.1		2.5		1.8	4	1.6	4.9	c	20.5	2862	25.649
66		137		67	97	137	162	$n_{2\text{Eck}}$			
66		77		67	79	65	79	$n_{2\text{th}}$			
989	431	987		1693	664	1520	455	M_2			
2.8	5.6	2.2		1.6	3.6	1.4	4.4	c	15.9	2914	29.228
58	80	120		59	85	120	142	$n_{2\text{Eck}}$			
58	80	72		59	69	58	69	$n_{2\text{th}}$			
1118	488	1115	357	1911	751	1715	515	M_2			
2.5	5.1	2	5.7	1.5	3.3	1.3	4	c	15.6	2984	32.94
52	71	107	126	52	76	107	126	$n_{2\text{Eck}}$			
52	71	62	74	52	61	49	61	$n_{2\text{th}}$			
								M_2			
								c	12.2	2670	35.193
								$n_{2\text{Eck}}$			
								$n_{2\text{th}}$			
1196	523	1192	383	2044	804	1834	552	M_2			
2.4	4.8	1.9	5.4	1.4	3.1	1.2	3.8	c	12.2	3029	35.193
48	67	100	118	49	71	100	118	$n_{2\text{Eck}}$			
48	66	64	70	49	57	50	57	$n_{2\text{th}}$			
1352	593	1347	434	2307	910	2070	625	M_2			
2.1	4.2	1.7	4.7	1.2	2.7	1.1	3.3	c	12	3002	39.662
43	59	89	105	43	63	89	105	$n_{2\text{Eck}}$			
43	59	53	62	43	51	42	51	$n_{2\text{th}}$			
1472	644	1464	471	2511	988	2251	678	M_2			
2	4.4	1.8	5	1.2	2.9	1.2	3.5	c	9	3024	43.146
39	54	81	96	40	58	82	96	$n_{2\text{Eck}}$			
39	54	55	57	40	47	45	47	$n_{2\text{th}}$			

$M \dots$ [Nm]
 $n \dots$ [min^{-1}]
 $J \dots$ [kgcm^2]

$P \dots$ [kW]
 $I \dots$ [A]
 i [-]
 c [-]

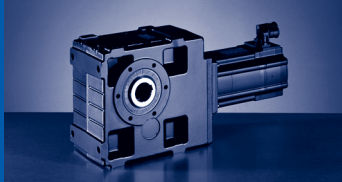

GKS [Nm]

GKS□□-□A (MCA)

$M_{2GN} \leq 3080 \text{ Nm}$

GKS09-3A				14LC16	14LC20	14LC35	14LC41	17NC17	17NC23	17NC35	17NC41
				...F10	...S00	...F10	...S00	...F10	...S00	...F10	...S00
i	M_{2GN}	J_G	M_1	12	6.7	10.8	5.4	21.5	10.8	19	9.5
			n_1	1635	2000	3455	4100	1680	2300	3480	4110
			I_{M400}	4.8	3.3	9.1	5.8	8.5	5.5	15.8	10.2
			P_N	2.1	1.4	3.9	2.3	3.8	2.6	6.9	4.1
			J_M	19.32	19.24	19.24	19.24	36.04	36.04	36.04	36.04
48.625	3017	8.87	M_2					972	473	860	418
			c				3	6	3	5.6	
			$n_{2 \text{ Eck}}$				35	47	72	85	
			$n_{2 \text{ th}}$				35	47	57	64	
58.456	2977	5.54	M_2	642		579					
			c	4.5		4.3					
			$n_{2 \text{ Eck}}$	28		59					
			$n_{2 \text{ th}}$	28		59					
58.456	3031	5.54	M_2					1174	575	1039	507
			c					2.5	5	2.5	4.7
			$n_{2 \text{ Eck}}$					29	39	60	70
			$n_{2 \text{ th}}$					29	39	53	53
65.879	3048	5.47	M_2	727		655		1327	651	1174	575
			c	4.1		3.9		2.3	4.4	2.2	4.2
			$n_{2 \text{ Eck}}$	25		52		26	35	53	62
			$n_{2 \text{ th}}$	25		52		26	35	47	47
70.982	3031	4.14	M_2	786		708		1433	704	1267	621
			c	3.8		3.6		2.1	4.1	2	3.8
			$n_{2 \text{ Eck}}$	23		49		24	32	49	58
			$n_{2 \text{ th}}$	23		49		24	32	44	44
79.996	3071	4.1	M_2	889		801		1619	797	1431	703
			c	3.4		3.2		1.9	3.7	1.8	3.5
			$n_{2 \text{ Eck}}$	20		43		21	29	44	51
			$n_{2 \text{ th}}$	20		43		21	29	39	39
91.86	3031	2.63	M_2	1026	559	925	450	1864	921	1648	812
			c	2.9	5.2	2.8	5.2	1.6	3.2	1.6	3
			$n_{2 \text{ Eck}}$	18	22	38	45	18	25	38	45
			$n_{2 \text{ th}}$	18	22	38	39	18	25	34	34
103.524	3080	2.61	M_2	1160	633	1045	510	2104	1041	1860	918
			c	2.6	4.7	2.5	4.7	1.5	2.9	1.4	2.7
			$n_{2 \text{ Eck}}$	16	19	33	40	16	22	34	40
			$n_{2 \text{ th}}$	16	19	33	35	16	22	30	30
111.484	3031	1.92	M_2	1252	685	1125	549	2269	1124	2003	988
			c	2.4	4.3	2.5	4.8	1.3	2.7	1.4	2.7
			$n_{2 \text{ Eck}}$	15	18	31	37	15	21	31	37
			$n_{2 \text{ th}}$	15	18	31	32	15	21	28	28
125.641	3080	1.9	M_2	1415	776	1272	622	2560	1270	2261	1116
			c	2.2	3.9	2.3	4.3	1.2	2.4	1.3	2.5
			$n_{2 \text{ Eck}}$	13	16	28	33	13	18	28	33
			$n_{2 \text{ th}}$	13	16	28	29	13	18	25	25
140.921	2973	1.26	M_2	1591	874	1430	702				
			c	1.9	3.4	2	3.8				
			$n_{2 \text{ Eck}}$	12	14	25	29				
			$n_{2 \text{ th}}$	12	14	25	25				
158.816	3080	1.25	M_2	1797	989	1615	794				
			c	1.7	3.1	1.8	3.4				
			$n_{2 \text{ Eck}}$	10	13	22	26				
			$n_{2 \text{ th}}$	10	13	22	23				
182	3031	2.25	M_2	2064	1139	1856	915		1855		1631
			c	1.5	2.6	1.6	2.9		1.6		1.7
			$n_{2 \text{ Eck}}$	9	11	19	23		13		23
			$n_{2 \text{ th}}$	9	11	19	20		13		17

$M \dots$ [Nm]
 $n \dots$ [min^{-1}]
 $J \dots$ [kgcm^2]

$P \dots$ [kW]
 $I \dots$ [A]
 i [-]
 c [-]

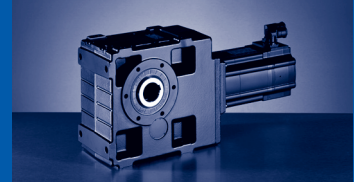

$M_{2GN} \leq 3080 \text{ Nm}$

195C17	195C23	195C35	195C42	21XC17	21XC25	21XC35	21XC42	GKS09-3A			
...F10	...S00	...F10	...S00	...F10	...S00	...F10	...S00	M_1	J_G	M_{2GN}	i
36.3	16.3	36	12	61.4	24.6	55	17	n_1			
1700	2340	3510	4150	1710	2490	3520	4160	I_{M400}			
13.9	8.2	28.7	14	22.5	13.5	42.5	19.8	P_N			
6.4	4	13.2	5.2	11	6.4	20.3	7.4	J_M			
72.12	72.12	72.04	72.12	180.04	180.04	180.04	180.04	M_2			
1662	730	1653	534	2834	1118	2540	768	c	8.87	3017	48.625
1.8	3.9	1.6	4.4	1.1	2.6	1	3.1	$n_{2 \text{ Eck}}$			
35	48	72	85	35	51	72	86	$n_{2 \text{ th}}$			
35	48	46	50	35	41	38	41	M_2			
								c	5.54	2977	58.456
								$n_{2 \text{ Eck}}$			
								$n_{2 \text{ th}}$			
2005	883	1993	647					M_2			
1.5	3.3	1.3	3.7					c	5.54	3031	58.456
29	40	60	71					$n_{2 \text{ Eck}}$			
29	40	42	42					$n_{2 \text{ th}}$			
2263	999	2249	733					M_2			
1.3	2.9	1.2	3.3					c	5.47	3048	65.879
26	36	53	63					$n_{2 \text{ Eck}}$			
26	36	36	37					$n_{2 \text{ th}}$			
2441	1079	2425	792					M_2			
1.2	2.7	1.1	3					c	4.14	3031	70.982
24	33	50	59					$n_{2 \text{ Eck}}$			
24	33	35	35					$n_{2 \text{ th}}$			
2755	1220		895					M_2			
1.1	2.4		2.7					c	4.1	3071	79.996
21	29		52					$n_{2 \text{ Eck}}$			
21	29		31					$n_{2 \text{ th}}$			
								M_2			
								c	2.63	3031	91.86
								$n_{2 \text{ Eck}}$			
								$n_{2 \text{ th}}$			
								M_2			
								c	2.61	3080	103.524
								$n_{2 \text{ Eck}}$			
								$n_{2 \text{ th}}$			
								M_2			
								c	1.92	3031	111.484
								$n_{2 \text{ Eck}}$			
								$n_{2 \text{ th}}$			
								M_2			
								c	1.9	3080	125.641
								$n_{2 \text{ Eck}}$			
								$n_{2 \text{ th}}$			
								M_2			
								c	1.26	2973	140.921
								$n_{2 \text{ Eck}}$			
								$n_{2 \text{ th}}$			
								M_2			
								c	1.25	3080	158.816
								$n_{2 \text{ Eck}}$			
								$n_{2 \text{ th}}$			
								M_2			
								c	2.25	3031	182
								$n_{2 \text{ Eck}}$			
								$n_{2 \text{ th}}$			

$M \dots$ [Nm]
 $n \dots$ [min^{-1}]
 $J \dots$ [kgcm^2]

$P \dots$ [kW]
 $I \dots$ [A]
 i [-]
 c [-]

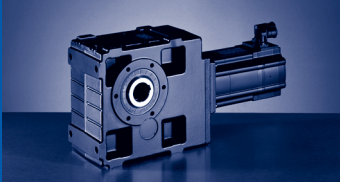

GKS [Nm]

GKS□□-□A (MCA)

$M_{2GN} \leq 3080 \text{ Nm}$

GKS09-3A				14LC16	14LC20	14LC35	14LC41	17NC17	17NC23	17NC35	17NC41
				...F10	...S00	...F10	...S00	...F10	...S00	...F10	...S00
i	M_{2GN}	J_G	M_1								
			n_1	12	6.7	10.8	5.4	21.5	10.8	19	9.5
			I_{M400}	1635	2000	3455	4100	1680	2300	3480	4110
			P_N	4.8	3.3	9.1	5.8	8.5	5.5	15.8	10.2
			J_M	2.1	1.4	3.9	2.3	3.8	2.6	6.9	4.1
			M_2	19.32	19.24	19.24	19.24	36.04	36.04	36.04	36.04
205.111	3080	2.24	c	2330	1287	2095	1034		2094		1841
			$n_{2 \text{ Eck}}$	1.3	2.4	1.4	2.6		1.5		1.5
			$n_{2 \text{ th}}$	8	10	17	20		11		20
				8	10	17	18		11		15
220.882	3031	1.66	M_2	2512	1389	2259	1116		2258		1985
			c	1.2	2.2	1.3	2.4		1.3		1.4
			$n_{2 \text{ Eck}}$	7	9	16	19		10		19
			$n_{2 \text{ th}}$	7	9	16	16		10		14
248.93	3080	1.65	M_2	2835	1568	2550	1261		2548		2241
			c	1.1	1.9	1.2	2.2		1.2		1.2
			$n_{2 \text{ Eck}}$	7	8	14	17		9		17
			$n_{2 \text{ th}}$	7	8	14	14		9		13
279.205	3031	1.1	M_2		1764	2864	1418				
			c		1.7	1	1.9				
			$n_{2 \text{ Eck}}$		7	12	15				
			$n_{2 \text{ th}}$		7	12	13				
314.659	3080	1.1	M_2		1991		1602				
			c		1.5		1.7				
			$n_{2 \text{ Eck}}$		6		13				
			$n_{2 \text{ th}}$		6		11				

M ... [Nm]
 n ... [min⁻¹]
 J ... [kgcm²]

P ... [kW]
 I ... [A]
 i [-]
 c [-]

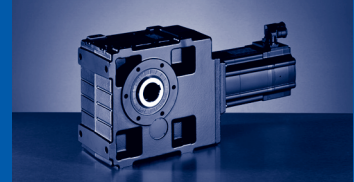

$M_{2GN} \leq 3080 \text{ Nm}$

195C17	195C23	195C35	195C42	21XC17	21XC25	21XC35	21XC42	GKS09-3A			
...F10	...S00	...F10	...S00	...F10	...S00	...F10	...S00	M_1	J_G	M_{2GN}	i
36.3	16.3	36	12	61.4	24.6	55	17	n_1			
1700	2340	3510	4150	1710	2490	3520	4160	I_{M400}			
13.9	8.2	28.7	14	22.5	13.5	42.5	19.8	P_N			
6.4	4	13.2	5.2	11	6.4	20.3	7.4	J_M			
72.12	72.12	72.04	72.12	180.04	180.04	180.04	180.04	M_2 c n_{2Eck} n_{2th}	2.24	3080	205.111
								M_2 c n_{2Eck} n_{2th}	1.66	3031	220.882
								M_2 c n_{2Eck} n_{2th}	1.65	3080	248.93
								M_2 c n_{2Eck} n_{2th}	1.1	3031	279.205
								M_2 c n_{2Eck} n_{2th}	1.1	3080	314.659

M ... [Nm]
n ... [min⁻¹]
J ... [kgcm²]

P ... [kW]
I ... [A]
i [-]
c [-]

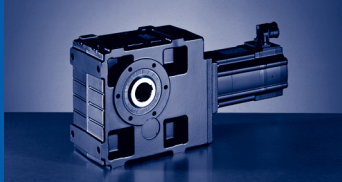

GKS [Nm]

GKS□□-□A (MCA)

$M_{2GN} \leq 3080 \text{ Nm}$

GKS09-4A				10IC40	13IC34	13IC41	14LC16	14LC20	14LC35	14LC41	17NC17	17NC23	17NC35	17NC41
				...S00	...F10	...S00	...F10	...S00	...F10	...S00	...F10	...S00	...F10	...S00
i	M_{2GN}	J_G	M_1	2	6.3	4	12	6.7	10.8	5.4	21.5	10.8	19	9.5
			n_1	3950	3410	4050	1635	2000	3455	4100	1680	2300	3480	4110
			I_{M400}	2.4	6	4.4	4.8	3.3	9.1	5.8	8.5	5.5	15.8	10.2
			P_N	0.8	2.2	1.7	2.1	1.4	3.9	2.3	3.8	2.6	6.9	4.1
			J_M	2.44	8.34	8.34	19.32	19.24	19.24	19.24	36.04	36.04	36.04	36.04
100.551	3029	2.48	M_2		570		1106	603	997	486	2008	993	1775	875
			c		4.4		2.7	4.8	2.6	4.9	1.5	2.9	1.5	2.8
			$n_{2 \text{ Eck}}$		34		16	20	34	41	17	23	35	41
			$n_{2 \text{ th}}$		34		16	20	34	36	17	23	31	31
113.32	3002	2.46	M_2		643		1251	684	1124	549	2267	1123	2001	987
			c		4.3		2.4	4.2	2.5	4.7	1.3	2.6	1.4	2.7
			$n_{2 \text{ Eck}}$		30		14	18	31	36	15	20	31	36
			$n_{2 \text{ th}}$		30		14	18	30	32	15	20	27	27
123.275	3024	2.11	M_2		702	436	1364	747	1226	599	2469	1224	2180	1076
			c		4	5.9	2.2	3.9	2.3	4.4	1.2	2.4	1.3	2.5
			$n_{2 \text{ Eck}}$		28	33	13	16	28	33	14	19	28	33
			$n_{2 \text{ th}}$		28	33	13	16	28	29	14	19	25	25
138.929	3017	2.09	M_2		795	495	1541	846	1385	679	2787	1384	2460	1216
			c		3.5	5.3	1.9	3.5	2.1	3.9	1.1	2.2	1.2	2.2
			$n_{2 \text{ Eck}}$		25	29	12	14	25	30	12	17	25	30
			$n_{2 \text{ th}}$		25	29	12	14	25	26	12	17	22	22
151.012	3024	1.52	M_2		867	541	1678	922	1508	740		1507	2677	1325
			c		3.3	4.9	1.8	3.2	1.9	3.6		2	1.1	2
			$n_{2 \text{ Eck}}$		23	27	11	13	23	27		15	23	27
			$n_{2 \text{ th}}$		23	27	11	13	23	24		15	21	21
170.188	3017	1.51	M_2		981	613	1895	1044	1704	838		1702		1497
			c		2.9	4.3	1.6	2.8	1.7	3.2		1.8		1.8
			$n_{2 \text{ Eck}}$		20	24	10	12	20	24		14		24
			$n_{2 \text{ th}}$		20	24	10	12	20	21		14		18
204.596	3031	1.24	M_2		1185	743	2285	1261	2054	1013		2053		1805
			c		2.4	3.6	1.3	2.4	1.4	2.7		1.5		1.5
			$n_{2 \text{ Eck}}$		17	20	8	10	17	20		11		20
			$n_{2 \text{ th}}$		17	20	8	10	17	18		11		15
230.577	3048	1.24	M_2		1340	841	2579	1425	2319	1146		2317		2038
			c		2.2	3.2	1.2	2.1	1.3	2.4		1.3		1.3
			$n_{2 \text{ Eck}}$		15	18	7	9	15	18		10		18
			$n_{2 \text{ th}}$		15	18	7	9	15	16		10		13
248.439	3031	1.13	M_2		1446	908	2781	1538	2501	1237		2500		2198
			c		2	3	1.1	2	1.2	2.2		1.2		1.2
			$n_{2 \text{ Eck}}$		14	16	7	8	14	17		9		17
			$n_{2 \text{ th}}$		14	16	7	8	14	14		9		13
279.986	3071	1.13	M_2		1633	1027		1737	2822	1397		2821		2481
			c		1.8	2.7		1.8	1	2		1.1		1.1
			$n_{2 \text{ Eck}}$		12	15		7	12	15		8		15
			$n_{2 \text{ th}}$		12	14		7	12	13		8		11
323.365	3031	0.71	M_2	581	1891	1191		2012		1619				
			c	4.6	1.5	2.3		1.5		1.7				
			$n_{2 \text{ Eck}}$	12	11	13		6		13				
			$n_{2 \text{ th}}$	12	11	13		6		11				
364.427	3071	0.71	M_2	658	2135	1346		2271		1828				
			c	4.1	1.4	2		1.4		1.5				
			$n_{2 \text{ Eck}}$	11	9	11		6		11				
			$n_{2 \text{ th}}$	11	9	11		5		10				
402.234	3031	0.51	M_2	730	2360	1489		2511		2021				
			c	3.7	1.2	1.8		1.2		1.4				
			$n_{2 \text{ Eck}}$	10	9	10		5		10				
			$n_{2 \text{ th}}$	10	8	10		5		9				

$M \dots$ [Nm]
 $n \dots$ [min^{-1}]
 $J \dots$ [kgcm^2]

$P \dots$ [kW]
 $I \dots$ [A]
 $i \dots$ [-]
 $c \dots$ [-]

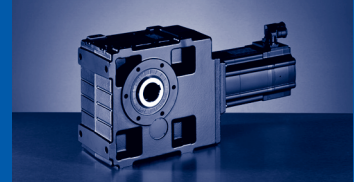

$M_{2GN} \leq 3080 \text{ Nm}$

GKS09-4A				10IC40	13IC34	13IC41	14LC16	14LC20	14LC35	14LC41	17NC17	17NC23	17NC35	17NC41
				...S00	...F10	...S00	...F10	...S00	...F10	...S00	...F10	...S00	...F10	...S00
i	M_{2GN}	J_G	M_1	2	6.3	4	12	6.7	10.8	5.4	21.5	10.8	19	9.5
			n_1	3950	3410	4050	1635	2000	3455	4100	1680	2300	3480	4110
			I_{M400}	2.4	6	4.4	4.8	3.3	9.1	5.8	8.5	5.5	15.8	10.2
			P_N	0.8	2.2	1.7	2.1	1.4	3.9	2.3	3.8	2.6	6.9	4.1
			J_M	2.44	8.34	8.34	19.32	19.24	19.24	19.24	36.04	36.04	36.04	36.04
453.311	3071	0.51	M_2	826	2664	1681		2833		2280				
			c	3.3	1.1	1.6		1.1		1.2				
			$n_{2 \text{ Eck}}$	9	8	9		4		9				
			$n_{2 \text{ th}}$	9	8	9		4		8				
520.538	3031	0.47	M_2	953		1936				2623				
			c	2.9		1.4				1				
			$n_{2 \text{ Eck}}$	8		8				8				
			$n_{2 \text{ th}}$	8		8				7				
586.638	3080	0.47	M_2	1077		2185								
			c	2.6		1.3								
			$n_{2 \text{ Eck}}$	7		7								
			$n_{2 \text{ th}}$	7		7								
631.744	3031	0.44	M_2	1163		2355								
			c	2.3		1.2								
			$n_{2 \text{ Eck}}$	6		6								
			$n_{2 \text{ th}}$	6		6								
711.965	3080	0.44	M_2	1314		2658								
			c	2.1		1.1								
			$n_{2 \text{ Eck}}$	6		6								
			$n_{2 \text{ th}}$	6		6								
817.551	3031	0.28	M_2	1513										
			c	1.8										
			$n_{2 \text{ Eck}}$	5										
			$n_{2 \text{ th}}$	5										
921.367	3080	0.28	M_2	1709										
			c	1.6										
			$n_{2 \text{ Eck}}$	4										
			$n_{2 \text{ th}}$	4										
992.209	3031	0.2	M_2	1843										
			c	1.5										
			$n_{2 \text{ Eck}}$	4										
			$n_{2 \text{ th}}$	4										
1118.204	3080	0.2	M_2	2080										
			c	1.4										
			$n_{2 \text{ Eck}}$	4										
			$n_{2 \text{ th}}$	4										
1254.197	3031	0.13	M_2	2338										
			c	1.2										
			$n_{2 \text{ Eck}}$	3										
			$n_{2 \text{ th}}$	3										
1413.461	3080	0.13	M_2	2638										
			c	1.1										
			$n_{2 \text{ Eck}}$	3										
			$n_{2 \text{ th}}$	3										

$M \dots$ [Nm]
 $n \dots$ [min^{-1}]
 $J \dots$ [kgcm^2]

$P \dots$ [kW]
 $I \dots$ [A]
 i [-]
 c [-]

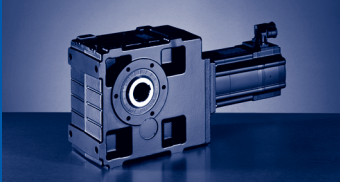

GKS [Nm]

GKS□□-□A (MCA)

$M_{2GN} \leq 6072 \text{ Nm}$

GKS11-3A				14LC16	14LC20	14LC35	14LC41	17NC17	17NC23	17NC35	17NC41
				...F10	...S00	...F10	...S00	...F10	...S00	...F10	...S00
i	M_{2GN}	J_G	M_1								
			n_1	12	6.7	10.8	5.4	21.5	10.8	19	9.5
			I_{M400}	1635	2000	3455	4100	1680	2300	3480	4110
			P_N	4.8	3.3	9.1	5.8	8.5	5.5	15.8	10.2
			J_M	2.1	1.4	3.9	2.3	3.8	2.6	6.9	4.1
			M_2	19.32	19.24	19.24	19.24	36.04	36.04	36.04	36.04
12.094	2770	104	c								
			n_2 Eck								
			n_2 th								
13.154	3013	101	M_2								
			c								
			n_2 Eck								
			n_2 th								
15.874	3090	68	M_2								
			c								
			n_2 Eck								
			n_2 th								
17.265	3360	66.5	M_2								
			c								
			n_2 Eck								
			n_2 th								
19.515	4470	90.3	M_2								
			c								
			n_2 Eck								
			n_2 th								
21.989	4884	90.4	M_2								
			c								
			n_2 Eck								
			n_2 th								
25.615	4985	61.2	M_2								
			c								
			n_2 Eck								
			n_2 th								
28.021	5163	52.2	M_2								
			c								
			n_2 Eck								
			n_2 th								
31.573	5521	51.3	M_2								
			c								
			n_2 Eck								
			n_2 th								
35.741	3935	36.8	M_2					698		621	
			c					5.2		4.6	
			n_2 Eck					47		97	
			n_2 th					47		63	
35.741	5655	36.8	M_2								
			c								
			n_2 Eck								
			n_2 th								
40.272	4434	36.2	M_2					786		699	
			c					5.2		4.6	
			n_2 Eck					42		86	
			n_2 th					42		56	
40.272	5869	36.2	M_2								
			c								
			n_2 Eck								
			n_2 th								

$M \dots$ [Nm]
 $n \dots$ [min^{-1}]
 $J \dots$ [kgcm^2]

$P \dots$ [kW]
 $I \dots$ [A]
 i [-]
 c [-]

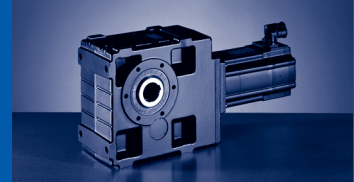

$M_{2GN} \leq 6072 \text{ Nm}$

195C17	195C23	195C35	195C42	21XC17	21XC25	21XC35	21XC42	GKS11-3A			
...F10	...S00	...F10	...S00	...F10	...S00	...F10	...S00	M_1	J_G	M_{2GN}	i
36.3	16.3	36	12	61.4	24.6	55	17	n_1			
1700	2340	3510	4150	1710	2490	3520	4160	I_{M400}			
13.9	8.2	28.7	14	22.5	13.5	42.5	19.8	P_N			
6.4	4	13.2	5.2	11	6.4	20.3	7.4	J_M			
72.12	72.12	72.04	72.12	180.04	180.04	180.04	180.04	M_2			
				685		617		c			
				3.8		3.3		n_{2Eck}	104	2770	12.094
				141		291		n_{2th}			
				131		127					
				745		671		M_2			
				3.8		3.3		c			
				130		268		n_{2Eck}	101	3013	13.154
				121		117		n_{2th}			
				904		814		M_2			
				3.2		2.8		c			
				108		222		n_{2Eck}	68	3090	15.874
				108		108		n_{2th}			
				984		885		M_2			
				3.2		2.8		c			
				99		204		n_{2Eck}	66.5	3360	17.265
				99		100		n_{2th}			
				1105		995		M_2			
				3.8		3.3		c			
				88		180		n_{2Eck}	90.3	4470	19.515
				81		79		n_{2th}			
				1247		1122		M_2			
				3.7		3.2		c			
				78		160		n_{2Eck}	90.4	4884	21.989
				72		69		n_{2th}			
				1459		1313		M_2			
				3.2		2.8		c			
				67		137		n_{2Eck}	61.2	4985	25.615
				67		67		n_{2th}			
924		927		1599		1438		M_2			
5.1		4.1		3		2.7		c			
61		125		61		126		n_{2Eck}	52.2	5163	28.021
61		69		61		63		n_{2th}			
1044		1047		1805		1623		M_2			
4.9		3.9		2.9		2.5		c			
54		111		54		112		n_{2Eck}	51.3	5521	31.573
54		61		54		55		n_{2th}			
								M_2			
								c	36.8	3935	35.741
								n_{2Eck}			
								n_{2th}			
1188		1190		2049	794	1842		M_2			
4.4		3.5		2.6	5.7	2.3		c			
48		98		48	70	99		n_{2Eck}	36.8	5655	35.741
48		60		48	56	54		n_{2th}			
								M_2			
								c	36.2	4434	40.272
								n_{2Eck}			
								n_{2th}			
1344		1345		2314	899	2080		M_2			
4.1		3.2		2.4	5.3	2.1		c			
42		87		43	62	87		n_{2Eck}	36.2	5869	40.272
42		52		42	50	47		n_{2th}			

$M \dots$ [Nm]
 $n \dots$ [min^{-1}]
 $J \dots$ [kgcm^2]

$P \dots$ [kW]
 $I \dots$ [A]
 i [-]
 c [-]

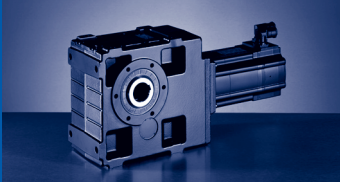

GKS [Nm]

GKS□□-□A (MCA)

$M_{2GN} \leq 6072 \text{ Nm}$

GKS11-3A				14LC16	14LC20	14LC35	14LC41	17NC17	17NC23	17NC35	17NC41
				...F10	...S00	...F10	...S00	...F10	...S00	...F10	...S00
i	M_{2GN}	J_G	M_1	12	6.7	10.8	5.4	21.5	10.8	19	9.5
			n_1	1635	2000	3455	4100	1680	2300	3480	4110
			I_{M400}	4.8	3.3	9.1	5.8	8.5	5.5	15.8	10.2
			P_N	2.1	1.4	3.9	2.3	3.8	2.6	6.9	4.1
			J_M	19.32	19.24	19.24	19.24	36.04	36.04	36.04	36.04
43.783	5800	27.9	M_2 c n_2 Eck n_2 th								
49.333	5923	27.5	M_2 c n_2 Eck n_2 th								
57.683	4370	17.7	M_2 c n_2 Eck n_2 th					1144 3.7 29 29		1012 3.6 60 50	
57.683	5972	17.7	M_2 c n_2 Eck n_2 th								
64.995	4924	17.5	M_2 c n_2 Eck n_2 th					1289 3.7 26 26		1141 3.6 54 45	
64.995	5992	17.5	M_2 c n_2 Eck n_2 th								
70.887	4497	13	M_2 c n_2 Eck n_2 th					1416 3.1 24 24		1252 3 49 44	608 5.7 58 44
70.887	5973	13	M_2 c n_2 Eck n_2 th								
79.873	5068	12.9	M_2 c n_2 Eck n_2 th					1595 3.1 21 21		1411 3 44 39	685 5.7 52 39
79.873	6032	12.9	M_2 c n_2 Eck n_2 th								
91.737	3979	8.3	M_2 c n_2 Eck n_2 th	1015 3.8 18 18		915 3.6 38 38					
91.737	4660	8.3	M_2 c n_2 Eck n_2 th					1844 2.5 18 18	903 4.9 25 25	1631 2.4 38 34	797 4.6 45 34
91.737	5975	8.3	M_2 c n_2 Eck n_2 th								

$M \dots$ [Nm]
 $n \dots$ [min^{-1}]
 $J \dots$ [kgcm^2]

$P \dots$ [kW]
 $I \dots$ [A]
 $i \dots$ [-]
 $c \dots$ [-]

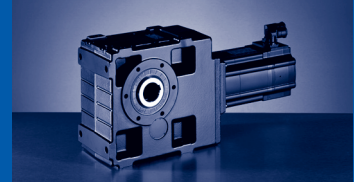

$M_{2GN} \leq 6072 \text{ Nm}$

195C17	195C23	195C35	195C42	21XC17	21XC25	21XC35	21XC42	GKS11-3A			
...F10	...S00	...F10	...S00	...F10	...S00	...F10	...S00	M_1	J_G	M_{2GN}	i
36.3	16.3	36	12	61.4	24.6	55	17	n_1			
1700	2340	3510	4150	1710	2490	3520	4160	I_{M400}			
13.9	8.2	28.7	14	22.5	13.5	42.5	19.8	P_N			
6.4	4	13.2	5.2	11	6.4	20.3	7.4	J_M			
72.12	72.12	72.04	72.12	180.04	180.04	180.04	180.04	M_2			
1464		1461		2519	975	2259		c			
3.8		3.3		2.3	5.4	2.2		$n_{2\text{ Eck}}$	27.9	5800	43.783
39		80		39	57	80		$n_{2\text{ th}}$			
39		55		39	46	46					
1657		1651		2845	1105	2551		M_2			
3.5		3		2.1	4.9	2		c	27.5	5923	49.333
35		71		35	51	71		$n_{2\text{ Eck}}$			
34		48		35	41	41		$n_{2\text{ th}}$			
								M_2			
								c	17.7	4370	57.683
								$n_{2\text{ Eck}}$			
								$n_{2\text{ th}}$			
1947		1939		3337	1302	2991	890	M_2			
3		2.6		1.8	4.3	1.7	5.2	c	17.7	5972	57.683
30		61		30	43	61	72	$n_{2\text{ Eck}}$			
29		42		30	35	35	35	$n_{2\text{ th}}$			
								M_2			
								c	17.5	4924	64.995
								$n_{2\text{ Eck}}$			
								$n_{2\text{ th}}$			
2202	955	2192		3767	1474	3377	1010	M_2			
2.7	5.8	2.3		1.6	3.8	1.5	4.6	c	17.5	5992	64.995
26	36	54		26	38	54	64	$n_{2\text{ Eck}}$			
26	36	38		26	31	31	31	$n_{2\text{ th}}$			
								M_2			
								c	13	4497	70.887
								$n_{2\text{ Eck}}$			
								$n_{2\text{ th}}$			
2407	1047	2396	766	4115	1613	3689	1106	M_2			
2.4	5.3	2.1	6	1.5	3.5	1.4	4.2	c	13	5973	70.887
24	33	50	59	24	35	50	59	$n_{2\text{ Eck}}$			
24	33	35	35	24	28	28	28	$n_{2\text{ th}}$			
								M_2			
								c	12.9	5068	79.873
								$n_{2\text{ Eck}}$			
								$n_{2\text{ th}}$			
2720	1187	2706	869	4644	1825	4162	1252	M_2			
2.2	4.8	1.9	5.4	1.3	3.1	1.2	3.8	c	12.9	6032	79.873
21	29	44	52	21	31	44	52	$n_{2\text{ Eck}}$			
21	29	31	31	21	25	25	25	$n_{2\text{ th}}$			
								M_2			
								c	8.3	3979	91.737
								$n_{2\text{ Eck}}$			
								$n_{2\text{ th}}$			
								M_2			
								c	8.3	4660	91.737
								$n_{2\text{ Eck}}$			
								$n_{2\text{ th}}$			
3133	1374	3116	1006					M_2			
1.9	4.1	1.6	4.6					c	8.3	5975	91.737
19	26	38	45					$n_{2\text{ Eck}}$			
19	26	27	27					$n_{2\text{ th}}$			

M ... [Nm]
n ... [min⁻¹]
J ... [kgcm²]

P ... [kW]
I ... [A]
i [-]
c [-]

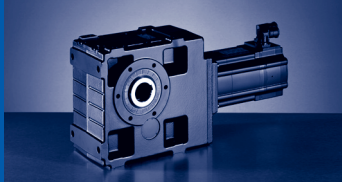

GKS [Nm]

GKS□□-□A (MCA)

$M_{2GN} \leq 6072 \text{ Nm}$

GKS11-3A				14LC16	14LC20	14LC35	14LC41	17NC17	17NC23	17NC35	17NC41
				...F10	...S00	...F10	...S00	...F10	...S00	...F10	...S00
i	M_{2GN}	J_G	M_1	12	6.7	10.8	5.4	21.5	10.8	19	9.5
			n_1	1635	2000	3455	4100	1680	2300	3480	4110
			I_{M400}	4.8	3.3	9.1	5.8	8.5	5.5	15.8	10.2
			P_N	2.1	1.4	3.9	2.3	3.8	2.6	6.9	4.1
			J_M	19.32	19.24	19.24	19.24	36.04	36.04	36.04	36.04
103.365	4483	8.21	M_2	1143		1031					
			c	3.8		3.6					
			$n_{2 \text{ Eck}}$	16		33					
			$n_{2 \text{ th}}$	16		33					
103.365	5250	8.21	M_2					2078	1017	1838	898
			c					2.5	4.9	2.4	4.6
			$n_{2 \text{ Eck}}$					16	22	34	40
			$n_{2 \text{ th}}$					16	22	30	30
103.365	6072	8.21	M_2								
			c								
			$n_{2 \text{ Eck}}$								
			$n_{2 \text{ th}}$								
111.335	4042	6.05	M_2	1240	673	1114					
			c	3.2	5.7	3.4					
			$n_{2 \text{ Eck}}$	15	18	31					
			$n_{2 \text{ th}}$	15	18	31					
111.335	4734	6.05	M_2					2248	1104	1983	970
			c					2.1	4.2	2.2	4.2
			$n_{2 \text{ Eck}}$					15	21	31	37
			$n_{2 \text{ th}}$					15	21	28	28
111.335	5975	6.05	M_2								
			c								
			$n_{2 \text{ Eck}}$								
			$n_{2 \text{ th}}$								
125.448	4555	5.99	M_2	1397	759	1255					
			c	3.2	5.7	3.4					
			$n_{2 \text{ Eck}}$	13	16	28					
			$n_{2 \text{ th}}$	13	16	28					
125.448	5335	5.99	M_2					2533	1244	2234	1093
			c					2.1	4.2	2.2	4.2
			$n_{2 \text{ Eck}}$					13	18	28	33
			$n_{2 \text{ th}}$					13	18	25	25
125.448	6072	5.99	M_2								
			c								
			$n_{2 \text{ Eck}}$								
			$n_{2 \text{ th}}$								
140.732	4107	3.96	M_2	1578	862	1418	690				
			c	2.6	4.6	2.7	5.1				
			$n_{2 \text{ Eck}}$	12	14	25	29				
			$n_{2 \text{ th}}$	12	14	25	26				
140.732	4811	3.96	M_2					2854	1408	2518	1238
			c					1.7	3.3	1.8	3.4
			$n_{2 \text{ Eck}}$					12	16	25	29
			$n_{2 \text{ th}}$					12	16	22	22
158.571	4628	3.93	M_2	1778	971	1597	778				
			c	2.6	4.6	2.7	5.1				
			$n_{2 \text{ Eck}}$	10	13	22	26				
			$n_{2 \text{ th}}$	10	13	22	23				
158.571	5421	3.93	M_2					3215	1587	2838	1395
			c					1.7	3.3	1.8	3.4
			$n_{2 \text{ Eck}}$					11	15	22	26
			$n_{2 \text{ th}}$					11	15	20	20

$M \dots$ [Nm]
 $n \dots$ [min^{-1}]
 $J \dots$ [kgcm^2]

$P \dots$ [kW]
 $I \dots$ [A]
 i [-]
 c [-]

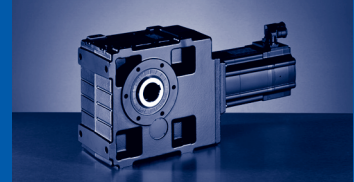

$M_{2GN} \leq 6072 \text{ Nm}$

195C17	195C23	195C35	195C42	21XC17	21XC25	21XC35	21XC42	GKS11-3A			
...F10	...S00	...F10	...S00	...F10	...S00	...F10	...S00	M_1	J_G	M_{2GN}	i
36.3	16.3	36	12	61.4	24.6	55	17	n_1			
1700	2340	3510	4150	1710	2490	3520	4160	I_{M400}			
13.9	8.2	28.7	14	22.5	13.5	42.5	19.8	P_N			
6.4	4	13.2	5.2	11	6.4	20.3	7.4	J_M			
72.12	72.12	72.04	72.12	180.04	180.04	180.04	180.04	M_2 c			
								n_2 Eck	8.21	4483	103.365
								n_2 th			
								M_2 c			
								n_2 Eck	8.21	5250	103.365
								n_2 th			
3538	1555	3517	1139					M_2 c			
1.7	3.7	1.5	4.2					n_2 Eck	8.21	6072	103.365
17	23	34	40					n_2 th			
16	23	24	24					M_2 c			
								n_2 Eck	6.05	4042	111.335
								n_2 th			
								M_2 c			
								n_2 Eck	6.05	4734	111.335
								n_2 th			
3816	1679	3787	1226					M_2 c			
1.6	3.5	1.5	4.2					n_2 Eck	6.05	5975	111.335
15	21	32	37					n_2 th			
15	21	22	22					M_2 c			
								n_2 Eck	5.99	4555	125.448
								n_2 th			
								M_2 c			
								n_2 Eck	5.99	5335	125.448
								n_2 th			
4307	1899	4274	1388					M_2 c			
1.4	3.1	1.3	3.8					n_2 Eck	5.99	6072	125.448
14	19	28	33					n_2 th			
14	19	20	20					M_2 c			
								n_2 Eck	3.96	4107	140.732
								n_2 th			
								M_2 c			
								n_2 Eck	3.96	4811	140.732
								n_2 th			
								M_2 c			
								n_2 Eck	3.93	4628	158.571
								n_2 th			
								M_2 c			
								n_2 Eck	3.93	5421	158.571
								n_2 th			

$M \dots$ [Nm]
 $n \dots$ [min^{-1}]
 $J \dots$ [kgcm^2]

$P \dots$ [kW]
 $I \dots$ [A]
 i [-]
 c [-]

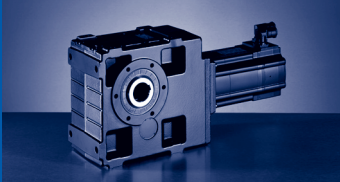

GKS [Nm]

GKS□□-□A (MCA)

$M_{2GN} \leq 6072 \text{ Nm}$

GKS11-3A				14LC16	14LC20	14LC35	14LC41	17NC17	17NC23	17NC35	17NC41
				...F10	...S00	...F10	...S00	...F10	...S00	...F10	...S00
i	M_{2GN}	J_G	M_1								
			n_1	12	6.7	10.8	5.4	21.5	10.8	19	9.5
			I_{M400}	1635	2000	3455	4100	1680	2300	3480	4110
			P_N	4.8	3.3	9.1	5.8	8.5	5.5	15.8	10.2
			J_M	2.1	1.4	3.9	2.3	3.8	2.6	6.9	4.1
			M_2	19.32	19.24	19.24	19.24	36.04	36.04	36.04	36.04
186.572	5975	7.07	c	2086	1137	1874	910	3787	1871	3343	1645
			$n_{2 \text{ Eck}}$	2.8	5	3	5.6	1.6	3.1	1.7	3.2
			$n_{2 \text{ th}}$	9	11	19	22	9	12	19	22
				9	11	19	19	9	12	17	17
210.222	5892	7.05	M_2	2359	1290	2120	1034	4276	2117	3775	1861
			c	2.5	4.4	2.6	4.9	1.4	2.7	1.5	2.8
			$n_{2 \text{ Eck}}$	8	10	16	20	8	11	17	20
			$n_{2 \text{ th}}$	8	10	16	17	8	11	15	15
226.431	5975	5.21	M_2	2545	1393	2287	1117	4610	2284	4070	2008
			c	2.3	4.2	2.5	4.6	1.3	2.6	1.4	2.6
			$n_{2 \text{ Eck}}$	7	9	15	18	7	10	15	18
			$n_{2 \text{ th}}$	7	9	15	16	7	10	14	14
255.133	5892	5.2	M_2	2877	1579	2586	1267	5203	2583	4594	2271
			c	2	3.6	2.2	4.1	1.1	2.3	1.2	2.3
			$n_{2 \text{ Eck}}$	6	8	14	16	7	9	14	16
			$n_{2 \text{ th}}$	6	8	14	14	7	9	12	12
286.219	5975	3.44	M_2	3234	1778	2907	1427	5844	2904	5160	2553
			c	1.8	3.3	1.9	3.7	1	2	1.1	2.1
			$n_{2 \text{ Eck}}$	6	7	12	14	6	8	12	14
			$n_{2 \text{ th}}$	6	7	12	13	6	8	11	11
322.5	5892	3.43	M_2	3653	2012	3284	1616		3281		2885
			c	1.6	2.9	1.7	3.2		1.8		1.8
			$n_{2 \text{ Eck}}$	5	6	11	13		7		13
			$n_{2 \text{ th}}$	5	6	11	11		7		10

$M \dots$ [Nm]
 $n \dots$ [min^{-1}]
 $J \dots$ [kgcm^2]

$P \dots$ [kW]
 $I \dots$ [A]
 $i \dots$ [-]
 $c \dots$ [-]

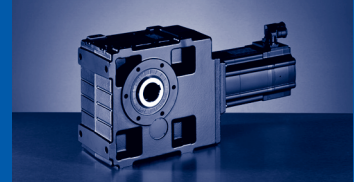

$M_{2GN} \leq 6072 \text{ Nm}$

195C17	195C23	195C35	195C42	21XC17	21XC25	21XC35	21XC42	GKS11-3A			
...F10	...S00	...F10	...S00	...F10	...S00	...F10	...S00	M_1	J_G	M_{2GN}	i
36.3	16.3	36	12	61.4	24.6	55	17	n_1			
1700	2340	3510	4150	1710	2490	3520	4160	I_{M400}			
13.9	8.2	28.7	14	22.5	13.5	42.5	19.8	P_N			
6.4	4	13.2	5.2	11	6.4	20.3	7.4	J_M			
72.12	72.12	72.04	72.12	180.04	180.04	180.04	180.04	M_2			
	2856		2093					c			
	2.1		2.5					$n_{2\text{ Eck}}$	7.07	5975	186.572
	13		22					$n_{2\text{ th}}$			
	13		13					M_2			
	3227		2366					c			
	1.8		2.2					$n_{2\text{ Eck}}$	7.05	5892	210.222
	11		20					$n_{2\text{ th}}$			
	11		12					M_2			
	3480		2552					c			
	1.7		2.1					$n_{2\text{ Eck}}$	5.21	5975	226.431
	10		18					$n_{2\text{ th}}$			
	10		11					M_2			
	3930		2883					c			
	1.5		1.8					$n_{2\text{ Eck}}$	5.2	5892	255.133
	9		16					$n_{2\text{ th}}$			
	9		10					M_2			
								c			
								$n_{2\text{ Eck}}$	3.44	5975	286.219
								$n_{2\text{ th}}$			
								M_2			
								c			
								$n_{2\text{ Eck}}$	3.43	5892	322.5
								$n_{2\text{ th}}$			

M ... [Nm]
n ... [min⁻¹]
J ... [kgcm²]

P ... [kW]
I ... [A]
i [-]
c [-]

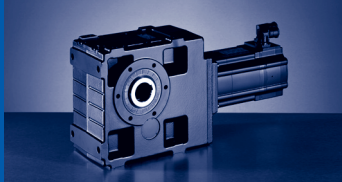

GKS [Nm]

GKS□□-□A (MCA)

$M_{2GN} \leq 6072 \text{ Nm}$

GKS11-4A				10IC40	13IC34	13IC41	14LC16	14LC20	14LC35	14LC41
				...S00	...F10	...S00	...F10	...S00	...F10	...S00
i	M_{2GN}	J_G	M_1							
			n_1	2	6.3	4	12	6.7	10.8	5.4
			I_{M400}	3950	3410	4050	1635	2000	3455	4100
			P_N	2.4	6	4.4	4.8	3.3	9.1	5.8
			J_M	0.8	2.2	1.7	2.1	1.4	3.9	2.3
			M_2	2.44	8.34	8.34	19.32	19.24	19.24	19.24
102.119	4012	7.28	c		570					
			$n_{2 \text{ Eck}}$		5.8					
			$n_{2 \text{ th}}$		33					
			$n_{2 \text{ th}}$		33					
102.119	5655	7.28	M_2				1096		989	
			c				4.9		4.7	
			$n_{2 \text{ Eck}}$				16		34	
			$n_{2 \text{ th}}$				16		34	
115.063	5869	7.21	M_2				1240		1113	
			c				4.6		4.8	
			$n_{2 \text{ Eck}}$				14		30	
			$n_{2 \text{ th}}$				14		30	
125.095	5800	6.23	M_2				1355		1216	
			c				4.1		4.4	
			$n_{2 \text{ Eck}}$				13		28	
			$n_{2 \text{ th}}$				13		28	
140.952	5923	6.19	M_2				1533		1376	
			c				3.8		4	
			$n_{2 \text{ Eck}}$				12		25	
			$n_{2 \text{ th}}$				12		25	
153.242	5800	4.5	M_2				1673		1503	
			c				3.4		3.6	
			$n_{2 \text{ Eck}}$				11		23	
			$n_{2 \text{ th}}$				11		23	
172.667	5923	4.47	M_2				1892	1028	1699	
			c				3.1	5.5	3.3	
			$n_{2 \text{ Eck}}$				10	12	20	
			$n_{2 \text{ th}}$				9	12	20	
201.89	5972	3.74	M_2				2222	1213	1997	971
			c				2.6	4.7	2.8	5.3
			$n_{2 \text{ Eck}}$				8	10	17	20
			$n_{2 \text{ th}}$				8	10	17	18
227.481	5992	3.72	M_2				2512	1374	2257	1101
			c				2.4	4.2	2.5	4.7
			$n_{2 \text{ Eck}}$				7	9	15	18
			$n_{2 \text{ th}}$				7	9	15	16
248.106	5973	3.36	M_2				2746	1505	2468	1207
			c				2.2	3.9	2.3	4.3
			$n_{2 \text{ Eck}}$				7	8	14	17
			$n_{2 \text{ th}}$				7	8	14	14
279.556	6032	3.34	M_2				3101	1703	2788	1366
			c				1.9	3.5	2	3.9
			$n_{2 \text{ Eck}}$				6	7	12	15
			$n_{2 \text{ th}}$				6	7	12	13
322.931	5973	2.09	M_2		1859	1161	3593	1978	3230	1588
			c		3	4.5	1.7	3	1.8	3.3
			$n_{2 \text{ Eck}}$		11	13	5	6	11	13
			$n_{2 \text{ th}}$		11	13	5	6	11	11
363.866	6032	2.08	M_2		2101	1315	4056	2236	3647	1796
			c		2.7	4	1.5	2.7	1.6	3
			$n_{2 \text{ Eck}}$		9	11	5	6	10	11
			$n_{2 \text{ th}}$		9	11	4	6	10	10

$M \dots$ [Nm]
 $n \dots$ [min^{-1}]
 $J \dots$ [kgcm^2]

$P \dots$ [kW]
 $I \dots$ [A]
 $i \dots$ [-]
 $c \dots$ [-]

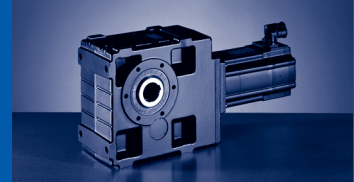

$M_{2GN} \leq 6072 \text{ Nm}$

17NC17	17NC23	17NC35	17NC41	19SC17	19SC23	19SC35	19SC42	GKS11-4A			
...F10	...S00	...F10	...S00	...F10	...S00	...F10	...S00	M_1	J_G	M_{2GN}	i
21.5	10.8	19	9.5	36.3	16.3	36	12	n_1			
1680	2300	3480	4110	1700	2340	3510	4150	I_{M400}			
8.5	5.5	15.8	10.2	13.9	8.2	28.7	14	P_N			
3.8	2.6	6.9	4.1	6.4	4	13.2	5.2	J_M			
36.04	36.04	36.04	36.04	72.12	72.12	72.04	72.12	M_2			
								c	7.28	4012	102.119
								n_2			
								Eck			
								n_2			
								th			
2011	981	1779	866	3438	1512	3418	1107	M_2			
2.8	5.4	2.7	5.1	1.6	3.6	1.4	4	c	7.28	5655	102.119
17	23	34	40	17	23	34	41	n_2			
16	23	30	30	17	23	24	24	Eck			
								n_2			
								th			
2272	1110	2003	975	3879	1707	3849	1247	M_2			
2.5	5.1	2.7	5.2	1.5	3.4	1.4	4.1	c	7.21	5869	115.063
15	20	30	36	15	20	31	36	n_2			
15	20	27	27	15	20	21	21	Eck			
								n_2			
								th			
2476	1213	2184	1066	4223	1862	4191	1361	M_2			
2.3	4.6	2.5	4.7	1.4	3.1	1.3	3.7	c	6.23	5800	125.095
13	18	28	33	14	19	28	33	n_2			
13	18	25	25	14	19	20	20	Eck			
								n_2			
								th			
2796	1373	2467	1207	4765	2105	4728	1539	M_2			
2.1	4.2	2.3	4.3	1.2	2.8	1.2	3.4	c	6.19	5923	140.952
12	16	25	29	12	17	25	29	n_2			
12	16	22	22	12	17	17	17	Eck			
								n_2			
								th			
3047	1500	2689	1318	5187	2295	5147	1680	M_2			
1.9	3.8	2	3.8	1.1	2.5	1.1	3	c	4.5	5800	153.242
11	15	23	27	11	15	23	27	n_2			
11	15	20	20	11	15	16	16	Eck			
								n_2			
								th			
3440	1696	3036	1491	5852	2593		1898	M_2			
1.7	3.4	1.8	3.5	1	2.3		2.8	c	4.47	5923	172.667
10	13	20	24	10	14		24	n_2			
10	13	18	18	10	14		14	Eck			
								n_2			
								th			
4032	1994	3559	1752		3042		2229	M_2			
1.5	2.9	1.6	3		1.9		2.4	c	3.74	5972	201.89
8	11	17	20		12		21	n_2			
8	11	15	15		12		12	Eck			
								n_2			
								th			
4551	2254	4018	1982		3435		2519	M_2			
1.3	2.6	1.4	2.7		1.7		2.1	c	3.72	5992	227.481
7	10	15	18		10		18	n_2			
7	10	14	14		10		11	Eck			
								n_2			
								th			
4970	2465	4388	2167		3753		2752	M_2			
1.2	2.4	1.3	2.4		1.6		1.9	c	3.36	5973	248.106
7	9	14	17		9		17	n_2			
7	9	13	13		9		10	Eck			
								n_2			
								th			
5608	2785	4951	2448		4236		3108	M_2			
1.1	2.1	1.2	2.2		1.4		1.7	c	3.34	6032	279.556
6	8	13	15		8		15	n_2			
6	8	11	11		8		9	Eck			
								n_2			
								th			
	3227		2838					M_2			
	1.8		1.9					c	2.09	5973	322.931
	7		13					n_2			
	7		10					Eck			
								n_2			
								th			
	3644		3204					M_2			
	1.6		1.7					c	2.08	6032	363.866
	6		11					n_2			
	6		9					Eck			
								n_2			
								th			

M ... [Nm]
n ... [min⁻¹]
J ... [kgcm²]

P ... [kW]
I ... [A]
i [-]
c [-]

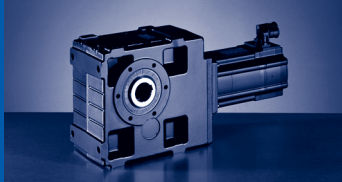

GKS [Nm]

GKS□□-□A (MCA)

$M_{2GN} \leq 6072 \text{ Nm}$

GKS11-4A				10IC40	13IC34	13IC41	14LC16	14LC20	14LC35	14LC41
				...500	...F10	...500	...F10	...500	...F10	...500
i	M_{2GN}	J_G	M_1							
			n_1	2	6.3	4	12	6.7	10.8	5.4
			I_{M400}	3950	3410	4050	1635	2000	3455	4100
			P_N	2.4	6	4.4	4.8	3.3	9.1	5.8
			J_M	0.8	2.2	1.7	2.1	1.4	3.9	2.3
			M_2	2.44	8.34	8.34	19.32	19.24	19.24	19.24
395.787	5973	1.52	c		2292	1436	4418	2439	3973	1959
			n_2 Eck		2.5	3.7	1.4	2.4	1.4	2.7
			n_2 th		9	10	4	5	9	10
					9	10	4	5	9	9
445.958	6032	1.52	M_2		2589	1625	4986	2755	4484	2214
			c		2.2	3.3	1.2	2.2	1.3	2.4
			n_2 Eck		8	9	4	5	8	9
			n_2 th		8	9	4	4	8	8
512.196	5975	1.39	M_2		2984	1876	5736	3175	5159	2553
			c		1.9	2.8	1	1.9	1.1	2.1
			n_2 Eck		7	8	3	4	7	8
			n_2 th		7	8	3	4	7	7
577.122	6072	1.38	M_2		3369	2120		3584		2882
			c		1.7	2.6		1.7		1.9
			n_2 Eck		6	7		4		7
			n_2 th		6	7		3		6
621.619	5975	1.31	M_2		3634	2289		3866		3110
			c		1.6	2.3		1.5		1.7
			n_2 Eck		6	7		3		7
			n_2 th		5	7		3		6
700.416	6072	1.31	M_2		4102	2585		4364		3511
			c		1.4	2.1		1.4		1.6
			n_2 Eck		5	6		3		6
			n_2 th		5	6		3		5
816.455	5975	0.82	M_2	1483	4793	3024		5098		4103
			c	3.6	1.2	1.8		1.2		1.3
			n_2 Eck	5	4	5		3		5
			n_2 th	5	4	5		2		4
919.949	6072	0.82	M_2	1677	5407	3414		5752		4630
			c	3.2	1.1	1.6		1.1		1.2
			n_2 Eck	4	4	4		2		5
			n_2 th	4	4	4		2		4
990.879	5975	0.6	M_2	1812		3683				4992
			c	3		1.5				1.1
			n_2 Eck	4		4				4
			n_2 th	4		4				4
1116.484	6072	0.6	M_2	2048		4156				
			c	2.7		1.3				
			n_2 Eck	4		4				
			n_2 th	4		4				
1252.516	5975	0.39	M_2	2306		4670				
			c	2.3		1.2				
			n_2 Eck	3		3				
			n_2 th	3		3				
1411.286	6072	0.39	M_2	2604		5269				
			c	2.1		1				
			n_2 Eck	3		3				
			n_2 th	3		3				

$M \dots$ [Nm]
 $n \dots$ [min^{-1}]
 $J \dots$ [kgcm^2]

$P \dots$ [kW]
 $I \dots$ [A]
 i [-]
 c [-]

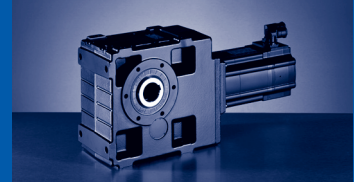

$M_{2GN} \leq 6072 \text{ Nm}$

17NC17	17NC23	17NC35	17NC41	19SC17	19SC23	19SC35	19SC42	GKS11-4A			
...F10	...S00	...F10	...S00	...F10	...S00	...F10	...S00	M_1	J_G	M_{2GN}	i
21.5	10.8	19	9.5	36.3	16.3	36	12	n_1			
1680	2300	3480	4110	1700	2340	3510	4150	I_{M400}			
8.5	5.5	15.8	10.2	13.9	8.2	28.7	14	P_N			
3.8	2.6	6.9	4.1	6.4	4	13.2	5.2	J_M			
36.04	36.04	36.04	36.04	72.12	72.12	72.04	72.12	M_2			
	3970		3491					c			
	1.5		1.5					$n_{2\text{ Eck}}$	1.52	5973	395.787
	6		10					$n_{2\text{ th}}$			
	6		8					M_2			
	4481		3940					c			
	1.3		1.4					$n_{2\text{ Eck}}$	1.52	6032	445.958
	5		9					$n_{2\text{ th}}$			
	5		7					M_2			
	5156		4534					c			
	1.2		1.2					$n_{2\text{ Eck}}$	1.39	5975	512.196
	5		8					$n_{2\text{ th}}$			
	4		6					M_2			
	5817		5116					c			
	1		1.1					$n_{2\text{ Eck}}$	1.38	6072	577.122
	4		7					$n_{2\text{ th}}$			
	4		5					M_2			
								c			
								$n_{2\text{ Eck}}$	1.31	5975	621.619
								$n_{2\text{ th}}$			
								M_2			
								c			
								$n_{2\text{ Eck}}$	1.31	6072	700.416
								$n_{2\text{ th}}$			
								M_2			
								c			
								$n_{2\text{ Eck}}$	0.82	5975	816.455
								$n_{2\text{ th}}$			
								M_2			
								c			
								$n_{2\text{ Eck}}$	0.82	6072	919.949
								$n_{2\text{ th}}$			
								M_2			
								c			
								$n_{2\text{ Eck}}$	0.6	5975	990.879
								$n_{2\text{ th}}$			
								M_2			
								c			
								$n_{2\text{ Eck}}$	0.6	6072	1116.484
								$n_{2\text{ th}}$			
								M_2			
								c			
								$n_{2\text{ Eck}}$	0.39	5975	1252.516
								$n_{2\text{ th}}$			
								M_2			
								c			
								$n_{2\text{ Eck}}$	0.39	6072	1411.286
								$n_{2\text{ th}}$			

M ... [Nm]
n ... [min⁻¹]
J ... [kgcm²]

P ... [kW]
I ... [A]
i [-]
c [-]

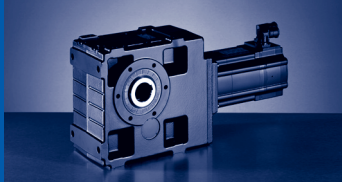

GKS [Nm]

GKS□□-□A (MCA)

$M_{2GN} \leq 11784 \text{ Nm}$

GKS14-3A				19SC17	19SC23	19SC35	19SC42	21XC17	21XC25	21XC35	21XC42
				...F10	...S00	...F10	...S00	...F10	...S00	...F10	...S00
i	M_{2GN}	J_G	M_1								
			n_1	1700	2340	3510	4150	1710	2490	3520	4160
			I_{M400}	13.9	8.2	28.7	14	22.5	13.5	42.5	19.8
			P_N	6.4	4	13.2	5.2	11	6.4	20.3	7.4
			J_M	72.12	72.12	72.04	72.12	180.04	180.04	180.04	180.04
16.646	5932	198	M_2					922		832	
			c				5.8		5.1		
			$n_{2 \text{ Eck}}$				103		212		
			$n_{2 \text{ th}}$				102		99		
18.311	6158	173	M_2					1017		918	
			c				5.5		4.8		
			$n_{2 \text{ Eck}}$				93		192		
			$n_{2 \text{ th}}$				93		92		
24.696	8801	183	M_2					1367		1234	
			c				5.8		5.1		
			$n_{2 \text{ Eck}}$				69		143		
			$n_{2 \text{ th}}$				69		67		
27.165	9135	159	M_2					1509		1362	
			c				5.5		4.8		
			$n_{2 \text{ Eck}}$				63		130		
			$n_{2 \text{ th}}$				63		62		
30.609	10132	156	M_2					1702		1536	
			c				5.4		4.8		
			$n_{2 \text{ Eck}}$				56		115		
			$n_{2 \text{ th}}$				56		55		
34.692	10019	111	M_2					1944		1752	
			c				4.7		4.1		
			$n_{2 \text{ Eck}}$				49		102		
			$n_{2 \text{ th}}$				49		55		
39.089	10937	109	M_2					2194		1977	
			c				4.6		4		
			$n_{2 \text{ Eck}}$				44		90		
			$n_{2 \text{ th}}$				44		48		
42.531	10787	82.4	M_2					2394		2149	
			c				4.3		4.1		
			$n_{2 \text{ Eck}}$				40		83		
			$n_{2 \text{ th}}$				40		47		
47.923	11261	81.1	M_2					2706		2429	
			c				4		3.9		
			$n_{2 \text{ Eck}}$				36		74		
			$n_{2 \text{ th}}$				36		42		
56.251	10874	54.2	M_2	1845		1846					
			c	5.6		4.8					
			$n_{2 \text{ Eck}}$	30		62					
			$n_{2 \text{ th}}$	30		44					
56.251	11522	54.2	M_2					3194		2866	
			c					3.5		3.4	
			$n_{2 \text{ Eck}}$					30		63	
			$n_{2 \text{ th}}$					30		36	
63.382	11477	53.5	M_2	2088		2087		3615		3243	
			c	5.3		4.5		3.1		3	
			$n_{2 \text{ Eck}}$	27		55		27		56	
			$n_{2 \text{ th}}$	27		39		27		32	
68.942	11454	38.9	M_2	2282		2279		3943		3537	
			c	4.8		4.2		2.9		2.7	
			$n_{2 \text{ Eck}}$	25		51		25		51	
			$n_{2 \text{ th}}$	25		36		25		29	

$M \dots$ [Nm]
 $n \dots$ [min^{-1}]
 $J \dots$ [kgcm^2]

$P \dots$ [kW]
 $I \dots$ [A]
 i [-]
 c [-]

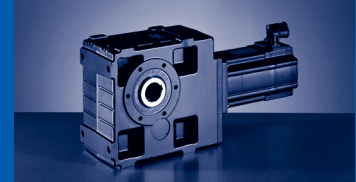

$M_{2GN} \leq 11784 \text{ Nm}$

GKS14-3A				195C17	195C23	195C35	195C42	21XC17	21XC25	21XC35	21XC42
				...F10	...500	...F10	...500	...F10	...500	...F10	...500
i	M_{2GN}	J_G	M_1	36.3	16.3	36	12	61.4	24.6	55	17
			n_1	1700	2340	3510	4150	1710	2490	3520	4160
			I_{M400}	13.9	8.2	28.7	14	22.5	13.5	42.5	19.8
			P_N	6.4	4	13.2	5.2	11	6.4	20.3	7.4
			J_M	72.12	72.12	72.04	72.12	180.04	180.04	180.04	180.04
77.681	11520	38.4	M_2	2585		2580		4457		3997	
			c	4.3		3.7		2.5		2.4	
			$n_{2 \text{ Eck}}$	22		45		22		45	
			$n_{2 \text{ th}}$	22		32		22		26	
90.551	11488	25.1	M_2	3034		3025		5216	2022	4677	
			c	3.7		3.2		2.2	5.2	2.1	
			$n_{2 \text{ Eck}}$	19		39		19	28	39	
			$n_{2 \text{ th}}$	19		27		19	22	22	
102.029	11639	24.9	M_2	3432		3421		5891	2292	5282	1566
			c	3.3		2.9		2	4.7	1.9	5.7
			$n_{2 \text{ Eck}}$	17		34		17	24	35	41
			$n_{2 \text{ th}}$	17		24		17	20	20	20
109.896	11784	18.3	M_2	3705		3691		6353	2476	5696	1693
			c	3.1		2.7		1.8	4.4	1.8	5.4
			$n_{2 \text{ Eck}}$	16		32		16	23	32	38
			$n_{2 \text{ th}}$	15		22		16	18	18	18
123.826	11639	18.1	M_2	4192		4163		7175	2801	6421	1911
			c	2.7		2.6		1.6	4	1.7	5.2
			$n_{2 \text{ Eck}}$	14		28		14	20	28	34
			$n_{2 \text{ th}}$	14		20		14	16	16	16
138.913	11784	12	M_2	4716	2049	4682					
			c	2.5	5.5	2.4					
			$n_{2 \text{ Eck}}$	12	17	25					
			$n_{2 \text{ th}}$	12	17	18					
156.522	11639	11.9	M_2	5331	2326	5292	1693				
			c	2.2	4.8	2.1	5.9				
			$n_{2 \text{ Eck}}$	11	15	22	27				
			$n_{2 \text{ th}}$	11	15	16	16				
186.572	11609	21.6	M_2	6379	2797	6331	2039	10874	4283	9734	2935
			c	1.8	4	1.7	4.9	1.1	2.7	1.1	3.5
			$n_{2 \text{ Eck}}$	9	13	19	22	9	13	19	22
			$n_{2 \text{ th}}$	9	13	13	13	9	11	11	11
210.222	11555	21.5	M_2	7203	3167	7149	2312		4842		3321
			c	1.6	3.6	1.5	4.3		2.4		3.1
			$n_{2 \text{ Eck}}$	8	11	17	20		12		20
			$n_{2 \text{ th}}$	8	11	12	12		10		10
226.431	11609	15.9	M_2	7767	3420	7708	2498		5224		3585
			c	1.5	3.3	1.4	4		2.2		2.9
			$n_{2 \text{ Eck}}$	8	10	16	18		11		18
			$n_{2 \text{ th}}$	8	10	11	11		9		9
255.133	11555	15.8	M_2	8768	3870	8701	2830		5903		4054
			c	1.3	2.9	1.3	3.6		1.9		2.5
			$n_{2 \text{ Eck}}$	7	9	14	16		10		16
			$n_{2 \text{ th}}$	7	9	10	10		8		8
286.219	11609	10.5	M_2	9850	4356	9774	3187				
			c	1.2	2.6	1.1	3.2				
			$n_{2 \text{ Eck}}$	6	8	12	15				
			$n_{2 \text{ th}}$	6	8	9	9				
322.5	11555	10.5	M_2	11115	4924		3605				
			c	1	2.3		2.8				
			$n_{2 \text{ Eck}}$	5	7		13				
			$n_{2 \text{ th}}$	5	7		8				

$M \dots$ [Nm]
 $n \dots$ [min^{-1}]
 $J \dots$ [kgcm^2]

$P \dots$ [kW]
 $I \dots$ [A]
 $i [-]$
 $c [-]$

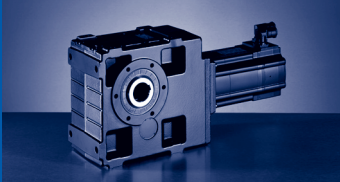

GKS [Nm]

GKS□□-□A (MCA)

$M_{2GN} \leq 11609 \text{ Nm}$

GKS14-4A				14LC16	14LC20	14LC35	14LC41	17NC17	17NC23	17NC35	17NC41
				...F10	...S00	...F10	...S00	...F10	...S00	...F10	...S00
i	M_{2GN}	J_G	M_1	12	6.7	10.8	5.4	21.5	10.8	19	9.5
			n_1	1635	2000	3455	4100	1680	2300	3480	4110
			I_{M400}	4.8	3.3	9.1	5.8	8.5	5.5	15.8	10.2
			P_N	2.1	1.4	3.9	2.3	3.8	2.6	6.9	4.1
			J_M	19.32	19.24	19.24	19.24	36.04	36.04	36.04	36.04
97.467	8508	23.47	M_2					1886		1669	
			c				4.4		4.2		
			$n_{2 \text{ Eck}}$				17		36		
			$n_{2 \text{ th}}$				17		32		
97.467	10019	23.47	M_2								
			c								
			$n_{2 \text{ Eck}}$								
			$n_{2 \text{ th}}$								
109.822	9586	23.23	M_2					2126		1881	
			c				4.4		4.2		
			$n_{2 \text{ Eck}}$				15		32		
			$n_{2 \text{ th}}$				15		28		
109.822	10937	23.23	M_2								
			c								
			$n_{2 \text{ Eck}}$								
			$n_{2 \text{ th}}$								
119.493	10431	19.94	M_2					2313		2036	
			c				4.4		4.7		
			$n_{2 \text{ Eck}}$				14		29		
			$n_{2 \text{ th}}$				14		26		
119.493	10787	19.94	M_2								
			c								
			$n_{2 \text{ Eck}}$								
			$n_{2 \text{ th}}$								
134.64	11261	19.78	M_2					2611		2299	
			c				4.2		4.5		
			$n_{2 \text{ Eck}}$				13		26		
			$n_{2 \text{ th}}$				12		23		
158.039	11522	16.44	M_2					3083		2716	
			c				3.6		3.9		
			$n_{2 \text{ Eck}}$				11		22		
			$n_{2 \text{ th}}$				11		20		
178.072	11477	16.35	M_2	1894				3490		3076	
			c	5.8			3.2		3.5		
			$n_{2 \text{ Eck}}$	9			9		20		
			$n_{2 \text{ th}}$	9			9		17		
193.754	11522	12.08	M_2					3808	1851	3357	
			c				3	5.9	3.2		
			$n_{2 \text{ Eck}}$				9	12	18		
			$n_{2 \text{ th}}$				9	12	16		
218.315	11477	12.02	M_2					4307	2102	3798	1847
			c				2.6	5.2	2.8	5.3	
			$n_{2 \text{ Eck}}$				8	11	16	19	
			$n_{2 \text{ th}}$				8	11	14	14	
237.467	11454	10.87	M_2					4696	2298	4141	2019
			c				2.4	4.8	2.6	4.9	
			$n_{2 \text{ Eck}}$				7	10	15	17	
			$n_{2 \text{ th}}$				7	10	13	13	
267.568	11520	10.83	M_2					5306	2604	4680	2288
			c				2.2	4.3	2.3	4.4	
			$n_{2 \text{ Eck}}$				6	9	13	15	
			$n_{2 \text{ th}}$				6	9	12	12	

$M \dots$ [Nm]
 $n \dots$ [min^{-1}]
 $J \dots$ [kgcm^2]

$P \dots$ [kW]
 $I \dots$ [A]
 i [-]
 c [-]

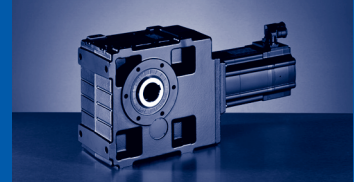

$M_{2GN} \leq 11609 \text{ Nm}$

195C17	195C23	195C35	195C42	21XC17	21XC25	21XC35	21XC42	GKS14-4A			
...F10	...S00	...F10	...S00	...F10	...S00	...F10	...S00	M_1	J_G	M_{2GN}	i
36.3	16.3	36	12	61.4	24.6	55	17	n_1			
1700	2340	3510	4150	1710	2490	3520	4160	I_{M400}			
13.9	8.2	28.7	14	22.5	13.5	42.5	19.8	P_N			
6.4	4	13.2	5.2	11	6.4	20.3	7.4	J_M			
72.12	72.12	72.04	72.12	180.04	180.04	180.04	180.04	M_2			
								c			
								$n_{2 \text{ Eck}}$	23.47	8508	97.467
								$n_{2 \text{ th}}$			
3232		3220		5541	2160	4968	1477	M_2			
3		2.6		1.8	4.3	1.7	5.2	c	23.47	10019	97.467
17		36		18	26	36	43	$n_{2 \text{ Eck}}$			
17		25		18	21	21	21	$n_{2 \text{ th}}$			
								M_2			
								c	23.23	9586	109.822
								$n_{2 \text{ Eck}}$			
								$n_{2 \text{ th}}$			
3645		3631		6246	2437	5600	1667	M_2			
2.9		2.5		1.7	4.2	1.7	5.1	c	23.23	10937	109.822
16		32		16	23	32	38	$n_{2 \text{ Eck}}$			
15		22		16	18	18	18	$n_{2 \text{ th}}$			
								M_2			
								c	19.94	10431	119.493
								$n_{2 \text{ Eck}}$			
								$n_{2 \text{ th}}$			
3978	1723	3950		6809	2659	6093	1814	M_2			
2.7	5.9	2.5		1.6	3.9	1.7	5.1	c	19.94	10787	119.493
14	20	29		14	21	30	35	$n_{2 \text{ Eck}}$			
14	20	20		14	17	17	17	$n_{2 \text{ th}}$			
4492	1951	4460		7681	3005	6874	2052	M_2			
2.5	5.5	2.4		1.5	3.6	1.5	4.7	c	19.78	11261	134.64
13	17	26		13	19	26	31	$n_{2 \text{ Eck}}$			
13	17	18		13	15	15	15	$n_{2 \text{ th}}$			
5291	2308	5252	1679	9034	3546	8086	2425	M_2			
2.2	4.8	2.1	5.8	1.3	3.2	1.4	4.1	c	16.44	11522	158.039
11	15	22	26	11	16	22	26	$n_{2 \text{ Eck}}$			
11	15	15	15	11	13	13	13	$n_{2 \text{ th}}$			
5977	2616	5933	1906	10195	4011	9126	2747	M_2			
1.9	4.2	1.8	5.2	1.1	2.8	1.2	3.6	c	16.35	11477	178.072
10	13	20	23	10	14	20	23	$n_{2 \text{ Eck}}$			
10	13	14	14	10	11	11	11	$n_{2 \text{ th}}$			
6514	2857	6465	2083	11104	4375	9940	2998	M_2			
1.8	3.9	1.7	4.8	1	2.6	1.1	3.4	c	12.08	11522	193.754
9	12	18	21	9	13	18	22	$n_{2 \text{ Eck}}$			
9	12	13	13	9	10	10	10	$n_{2 \text{ th}}$			
7356	3235	7300	2362		4945		3392	M_2			
1.6	3.5	1.5	4.2		2.3		3	c	12.02	11477	218.315
8	11	16	19		11		19	$n_{2 \text{ Eck}}$			
8	11	11	11		9		9	$n_{2 \text{ th}}$			
8012	3530	7951	2579		5390		3700	M_2			
1.4	3.2	1.4	3.9		2.1		2.7	c	10.87	11454	237.467
7	10	15	18		11		18	$n_{2 \text{ Eck}}$			
7	10	10	10		8		8	$n_{2 \text{ th}}$			
9043	3993	8973	2919		6088		4182	M_2			
1.3	2.8	1.2	3.5		1.9		2.4	c	10.83	11520	267.568
6	9	13	16		9		16	$n_{2 \text{ Eck}}$			
6	9	9	9		8		8	$n_{2 \text{ th}}$			

M ... [Nm]
n ... [min⁻¹]
J ... [kgcm²]

P ... [kW]
I ... [A]
i [-]
c [-]

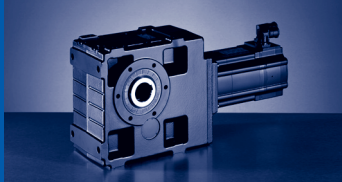

GKS [Nm]

GKS□□-□A (MCA)

$M_{2GN} \leq 11609 \text{ Nm}$

GKS14-4A				14LC16	14LC20	14LC35	14LC41	17NC17	17NC23	17NC35	17NC41
				...F10	...S00	...F10	...S00	...F10	...S00	...F10	...S00
i	M_{2GN}	J_G	M_1	12	6.7	10.8	5.4	21.5	10.8	19	9.5
			n_1	1635	2000	3455	4100	1680	2300	3480	4110
			I_{M400}	4.8	3.3	9.1	5.8	8.5	5.5	15.8	10.2
			P_N	2.1	1.4	3.9	2.3	3.8	2.6	6.9	4.1
			J_M	19.32	19.24	19.24	19.24	36.04	36.04	36.04	36.04
321.729	11454	6.42	M_2	3521	1912	3162		6405	3156	5652	2774
			c	3.2	5.7	3.4		1.8	3.5	1.9	3.6
			$n_{2 \text{ Eck}}$	5	6	11		5	7	11	13
			$n_{2 \text{ th}}$	5	6	11		5	7	10	10
362.512	11520	6.4	M_2	3982	2169	3577	1736	7232	3571	6383	3139
			c	2.8	5.1	3	5.7	1.6	3.2	1.7	3.2
			$n_{2 \text{ Eck}}$	5	6	10	11	5	6	10	11
			$n_{2 \text{ th}}$	5	6	10	10	5	6	9	9
390.671	11454	4.75	M_2	4302	2348	3865	1880	7804	3859	6888	3392
			c	2.6	4.7	2.8	5.2	1.5	2.9	1.6	3
			$n_{2 \text{ Eck}}$	4	5	9	11	4	6	9	11
			$n_{2 \text{ th}}$	4	5	9	9	4	6	8	8
440.193	11520	4.73	M_2	4862	2660	4369	2132	8808	4363	7775	3835
			c	2.3	4.2	2.5	4.7	1.3	2.6	1.4	2.7
			$n_{2 \text{ Eck}}$	4	5	8	9	4	5	8	9
			$n_{2 \text{ th}}$	4	5	8	8	4	5	7	7
513.121	11488	4.33	M_2	5688	3121	5112	2504	10288	5107	9083	4489
			c	2	3.6	2.1	4	1.1	2.2	1.2	2.3
			$n_{2 \text{ Eck}}$	3	4	7	8	3	5	7	8
			$n_{2 \text{ th}}$	3	4	7	7	3	4	6	6
578.164	11639	4.32	M_2	6423	3531	5774	2834	11606	5768	10248	5071
			c	1.8	3.2	1.9	3.6	1	2	1.1	2
			$n_{2 \text{ Eck}}$	3	4	6	7	3	4	6	7
			$n_{2 \text{ th}}$	3	3	6	6	3	4	5	5
622.742	11488	4.12	M_2	6929	3814	6230	3063		6224		5472
			c	1.7	3	1.8	3.3		1.8		1.9
			$n_{2 \text{ Eck}}$	3	3	6	7		4		7
			$n_{2 \text{ th}}$	3	3	6	6		4		5
701.681	11639	4.12	M_2	7822	4312	7033	3463		7027		6179
			c	1.5	2.7	1.6	3		1.7		1.7
			$n_{2 \text{ Eck}}$	2	3	5	6		3		6
			$n_{2 \text{ th}}$	2	3	5	5		3		4
805.901	11488	2.62	M_2	9003	4973	8096	3996		8091		7114
			c	1.3	2.3	1.4	2.6		1.4		1.5
			$n_{2 \text{ Eck}}$	2	3	4	5		3		5
			$n_{2 \text{ th}}$	2	2	4	4		3		4
908.058	11639	2.62	M_2	10159	5617	9136	4515		9130		8029
			c	1.1	2.1	1.2	2.3		1.3		1.3
			$n_{2 \text{ Eck}}$	2	2	4	5		3		5
			$n_{2 \text{ th}}$	2	2	4	4		3		3
978.071	11488	1.91	M_2	10953	6061	9851	4873		9846		8658
			c	1.1	1.9	1.1	2.1		1.2		1.2
			$n_{2 \text{ Eck}}$	2	2	4	4		2		4
			$n_{2 \text{ th}}$	2	2	4	4		2		3
1102.052	11639	1.91	M_2		6843		5504		11108		9768
			c		1.7		1.9		1.1		1.1
			$n_{2 \text{ Eck}}$		2		4		2		4
			$n_{2 \text{ th}}$		2		3		2		3
1236.326	11488	1.26	M_2		7694		6190				
			c		1.5		1.7				
			$n_{2 \text{ Eck}}$		2		3				
			$n_{2 \text{ th}}$		2		3				

$M \dots$ [Nm]
 $n \dots$ [min^{-1}]
 $J \dots$ [kgcm^2]

$P \dots$ [kW]
 $I \dots$ [A]
 $i \dots$ [-]
 $c \dots$ [-]

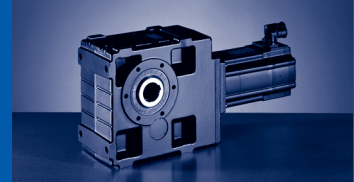

$M_{2GN} \leq 11609 \text{ Nm}$

195C17	195C23	195C35	195C42	21XC17	21XC25	21XC35	21XC42	GKS14-4A			
...F10	...S00	...F10	...S00	...F10	...S00	...F10	...S00	M_1	J_G	M_{2GN}	i
36.3	16.3	36	12	61.4	24.6	55	17	n_1			
1700	2340	3510	4150	1710	2490	3520	4160	I_{M400}			
13.9	8.2	28.7	14	22.5	13.5	42.5	19.8	P_N			
6.4	4	13.2	5.2	11	6.4	20.3	7.4	J_M			
72.12	72.12	72.04	72.12	180.04	180.04	180.04	180.04	M_2			
10899	4826	10814	3533					c	6.42	11454	321.729
1.1	2.3	1	2.9					$n_{2\text{Eck}}$			
5	7	11	13					$n_{2\text{th}}$			
5	7	8	8					M_2			
	5453		3995					c	6.4	11520	362.512
	2.1		2.6					$n_{2\text{Eck}}$			
	7		12					$n_{2\text{th}}$			
	6		7					M_2			
	5887		4314					c	4.75	11454	390.671
	1.9		2.4					$n_{2\text{Eck}}$			
	6		11					$n_{2\text{th}}$			
	6		6					M_2			
	6648		4874					c	4.73	11520	440.193
	1.7		2.1					$n_{2\text{Eck}}$			
	5		9					$n_{2\text{th}}$			
	5		6					M_2			
	7770		5700					c	4.33	11488	513.121
	1.5		1.8					$n_{2\text{Eck}}$			
	5		8					$n_{2\text{th}}$			
	5		5					M_2			
	8769		6436					c	4.32	11639	578.164
	1.3		1.6					$n_{2\text{Eck}}$			
	4		7					$n_{2\text{th}}$			
	4		4					M_2			
	9456		6942					c	4.12	11488	622.742
	1.2		1.5					$n_{2\text{Eck}}$			
	4		7					$n_{2\text{th}}$			
	4		4					M_2			
	10669		7834					c	4.12	11639	701.681
	1.1		1.3					$n_{2\text{Eck}}$			
	3		6					$n_{2\text{th}}$			
	3		3					M_2			
								c	2.62	11488	805.901
								$n_{2\text{Eck}}$			
								$n_{2\text{th}}$			
								M_2			
								c	2.62	11639	908.058
								$n_{2\text{Eck}}$			
								$n_{2\text{th}}$			
								M_2			
								c	1.91	11488	978.071
								$n_{2\text{Eck}}$			
								$n_{2\text{th}}$			
								M_2			
								c	1.91	11639	1102.052
								$n_{2\text{Eck}}$			
								$n_{2\text{th}}$			
								M_2			
								c	1.26	11488	1236.326
								$n_{2\text{Eck}}$			
								$n_{2\text{th}}$			

M ... [Nm]
n ... [min⁻¹]
J ... [kgcm²]

P ... [kW]
I ... [A]
i [-]
c [-]

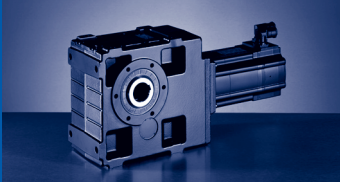

GKS [Nm]

GKS□□-□A (MCA)

$M_{2GN} \leq 11609 \text{ Nm}$

GKS14-4A				14LC16	14LC20	14LC35	14LC41	17NC17	17NC23	17NC35	17NC41
				...F10	...S00	...F10	...S00	...F10	...S00	...F10	...S00
i	M_{2GN}	J_G	M_1	12	6.7	10.8	5.4	21.5	10.8	19	9.5
			n_1	1635	2000	3455	4100	1680	2300	3480	4110
			I_{M400}	4.8	3.3	9.1	5.8	8.5	5.5	15.8	10.2
			P_N	2.1	1.4	3.9	2.3	3.8	2.6	6.9	4.1
			J_M	19.32	19.24	19.24	19.24	36.04	36.04	36.04	36.04
			M_2		8683		6987				
1393.043	11639	1.26	c		1.3		1.5				
			$n_{2 \text{ Eck}}$		1		3				
			$n_{2 \text{ th}}$		1		3				

M ... [Nm]
 n ... [min⁻¹]
 J ... [kgcm²]

P ... [kW]
 I ... [A]
 i [-]
 c [-]

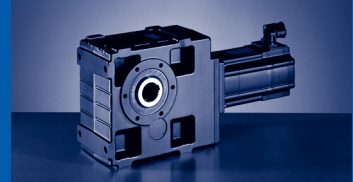

$M_{2GN} \leq 11609 \text{ Nm}$

195C17	195C23	195C35	195C42	21XC17	21XC25	21XC35	21XC42	GKS14-4A			
...F10	...S00	...F10	...S00	...F10	...S00	...F10	...S00	M_1	J_G	M_{2GN}	i
36.3	16.3	36	12	61.4	24.6	55	17	n_1			
1700	2340	3510	4150	1710	2490	3520	4160	I_{M400}			
13.9	8.2	28.7	14	22.5	13.5	42.5	19.8	P_N			
6.4	4	13.2	5.2	11	6.4	20.3	7.4	J_M			
72.12	72.12	72.04	72.12	180.04	180.04	180.04	180.04	M_2			
								c	1.26	11639	1393.043
								$n_{2 \text{ Eck}}$			
								$n_{2 \text{ th}}$			

M ... [Nm]
n ... [min^{-1}]
J ... [kgcm^2]

P ... [kW]
I ... [A]
i [-]
c [-]

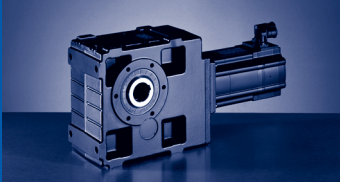

GKS [mm]

GKS□□-3S (MCS)

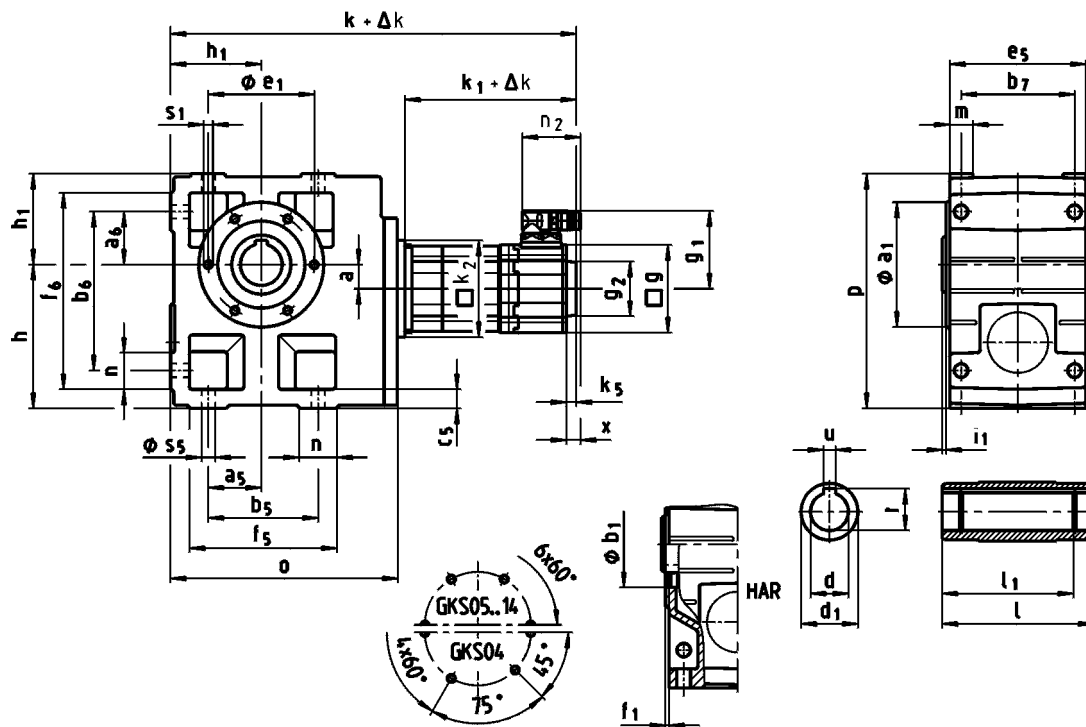

GKS□□-3S H□□ ... RSO

		06C C41	06F C41	06I C41	09D C41	09F C38	09H C41	09L C41	12D C20	12D C41	12H C15	12H C30	12H C35	12L C20	12L C41	
GKS04...	k	347	377	407	399	419	439	479								
GKS05...	k	367	397	427	419	439	459	499	436			476			516	
GKS06...	k	423	453	483	475	495	515	555	492			532			572	
GKS07...	k				531	551	571	611	548			588			628	
GKS09...	k								619			659			699	
...RSO B0 ¹⁾	Δk	0														
...RSO P□ ¹⁾	Δk	19				20										
	k ₁	132	162	192	183	203	223	263	188			228			268	
	k ₂	66			91								118			
	g	62			89								116			
...RSO	k ₅	0			13								14			
	g ₂	□ 62			Ø 67								Ø 72			
	g ₁	76			90								105			
	n ₂	64							78							
	x					21								18		

¹⁾ → 801 - SRS / SRM / ECN/ EQN / EQI / C20

²⁾ GKS05: 12DC20 ... 12LC41

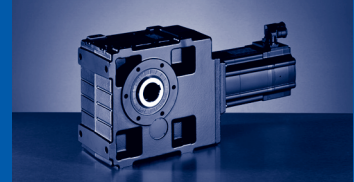

GKS□□-3S H□R ... RSO

		14D C15	14D C36	14H C15	14H C32	14L C15	14L C32	14P C14	14P C32	19F C14	19F C30	19J C14	19J C30	19P C14	19P C30	
GKS06...	k	508		548		588		628								
GKS07...	k	564		604		644		684		603		643		703		
GKS09...	k	635		675		715		755		674		714		774		
GKS11...	k	726		766		806		846		765		805		865		
GKS14...	k									864		904		964		
...RSO B0 ¹⁾	Δ k	0														
...RSO P□ ¹⁾	Δ k	28						34			44					
	k ₁	201		241		281		321		220		260		320		
	k ₂	145						195								
	g	143						192								
...RSO	k ₅	24						15								
	g ₂	Ø 78														
	g ₁	116				147		116	147	141	172	141	172	141	172	
	n ₂	78				94		78	94	78	94	78	94	78	94	
	x	16				38		16	38	16	36	16	36	16	36	

1) → 801 - SRS / SRM / ECN / EQN / EQI / C20

GKS□□-3S H□R

	o	p	h	h ₁	a	a ₅	a ₆	b ₅	b ₆	b ₇	c ₅	e ₅	f ₅	f ₆	m	n	s ₅
GKS04...	203	171	100	71	20	45	45	110	119	85	14	105	132	141	21	22	9
GKS05...	232	205	125	80	23	47.5	47.5	115	140	105	17	127	144	169		29	11
GKS06...	291	250	150	100	28	60	60	155	170	120	20	145	191	206	23	36	14
GKS07...	354	310	190	120	34	70	70	190	210	150	25	180	235	255	28	45	18
GKS09...	429	386	236	150	41	90	90	240	266	185	30	222	300	326	37	60	22
GKS11...	527	485	300	185	54	105	105	290	325	225	40	270	363	398	43	73	26
GKS14...	636	605	375	230	67	135	135	360	415	275	50	328	442	497	52	82	33

	d	l	d ₁	l ₁	u	t	a ₁	b ₁	e ₁	f ₁	i ₁	s ₁
	H7				JS9	+0,2		H7				
GKS04...	25	115	45	100	8	28.3	105	75	90	3	2.5	M6x12
	30					33.3						
GKS05...	35	140	50	124	10	38.3	118	80	100	4	4	M8x15
	40					43.3						
GKS06...	45	160	65	140	14	48.8	140	100	120	5	5	M10x16
	50					53.8						
GKS07...	55	200	75	175	16	59.3	165	115	140	6	6	M12x18
	60					64.4						
GKS09...	70	240	95	210	20	74.9	205	145	175	7	7	M16x24
	80					85.4						
GKS11...	80	290	105	250	22	85.4	240	140	205	6	6	M20x32
GKS14...	100	350	135	305	28	106.4	290	170	250	7	7	M24x35

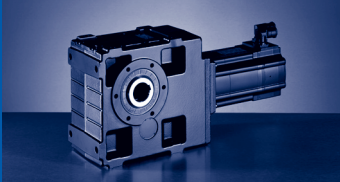

GKS [mm]

GKS□□-3S (MCS)

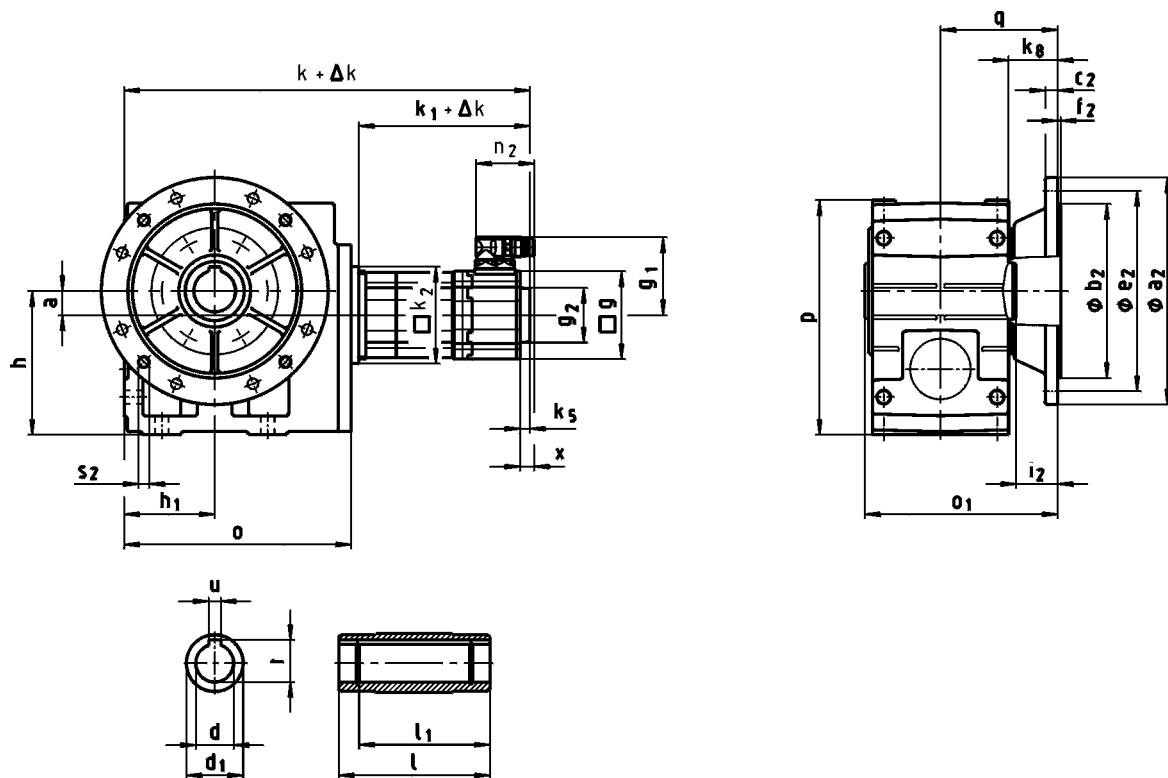

GKS□□-3S HAK ... RSO

		06C C41	06F C41	06I C41	09D C41	09F C38	09H C41	09L C41	12D C20	12D C41	12H C15	12H C30	12H C35	12L C20	12L C41
GKS04...	k	347	377	407	399	419	439	479							
GKS05...	k	367	397	427	419	439	459	499	436			476			516
GKS06...	k	423	453	483	475	495	515	555	492			532			572
GKS07...	k				531	551	571	611	548			588			628
GKS09...	k								619			659			699
...RSO B0 ¹⁾	Δk	0													
...RSO P□ ¹⁾	Δk	19			20										
...RSO	k_1	132	162	192	183	203	223	263	188		228		268		
	k_2	66			91				118						
	g	62			89				116						
	k_5	0			13				14						
	g_2	□ 62			Ø 67				Ø 72						
	g_1	76			90				105						
	n_2	64			78										
	x	21							18						

¹⁾ → 801 - SRS / SRM / ECN / EQN / EQI / C20

²⁾ GKS05: 12DC20 ... 12LC41

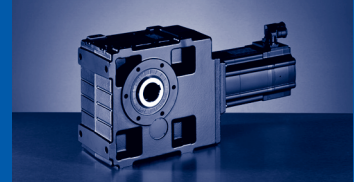

GKS□□-3S HAK ... RSO

		14D C15	14D C36	14H C15	14H C32	14L C15	14L C32	14P C14	14P C32	19F C14	19F C30	19J C14	19J C30	19P C14	19P C30				
GKS06...	k	508		548		588		628											
GKS07...	k	564		604		644		684		603		643		703					
GKS09...	k	635		675		715		755		674		714		774					
GKS11...	k	726		766		806		846		765		805		865					
GKS14...	k									864		904		964					
...RSO B0 ¹⁾	Δ k	0																	
...RSO P□ ¹⁾	Δ k	28						34			44								
	k ₁	201		241		281		321		220		260		320					
	k ₂	145						195											
	g	143						192											
...RSO	k ₅	24						15											
	g ₂	Ø 78																	
	g ₁	116				147		116		147		141		172		141		172	
	n ₂	78				94		78		94		78		94		78		94	
	x	16				38		16		38		16		36		16		36	

1) → 801 - SRS / SRM / ECN / EQN / EQI / C20

GKS□□-3S HAK

	o	o ₁	p	h	h ₁	a	q	k _g
GKS04...	203	149	171	100	71	20	91	39
GKS05...	232	174	205	125	80	23	103.5	40
GKS06...	291	203 ²⁾ 202 ³⁾	250	150	100	28	122.5 ²⁾ 121.5 ³⁾	50 ²⁾ 49 ³⁾
GKS07...	354	256	310	190	120	34	155.5	66
GKS09...	429	301	386	236	150	41	180.5	70
GKS11...	527	351	485	300	185	54	205.5	71
GKS14...	636	411	605	375	230	67	235.5	72

2) a₂ = 200

3) a₂ = 250

	d	l	d ₁	l ₁	u	t	a ₂	b ₂	c ₂	e ₂	f ₂	i ₂	s ₂
	H7				JS9	+0,2		j7					
GKS04...	25	115	45	100	8	28.3	160	110	10	130	3.5	33.5	4 x 9
	30					33.3							
GKS05...	35	140	50	124	10	38.3	200	130	12	165	4	42.5	4 x 11
	40					43.3							
GKS06...	45	160	65	140	14	48.8	250	180	15	215	5	41.5	4 x 14
	50					53.8							
GKS07...	55	200	75	175	16	59.3	300	230	17	265	4	55.5	4 x 17.5
	60					64.4							
GKS09...	70	240	95	210	20	74.9	350	250	18	300	5	60.5	4 x 17.5
	80					85.4							
GKS11...	80	290	105	250	22	85.4	400	300	20	350	5	60.5	4 x 17.5
	100					106.4							
GKS14...	100	350	135	305	28	106.4	450	350	22	400	5	60.5	8 x 17.5

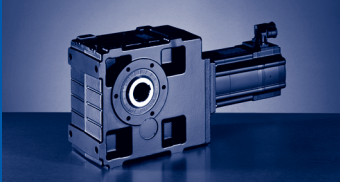

GKS [mm]

GKS□□-3S (MCS)

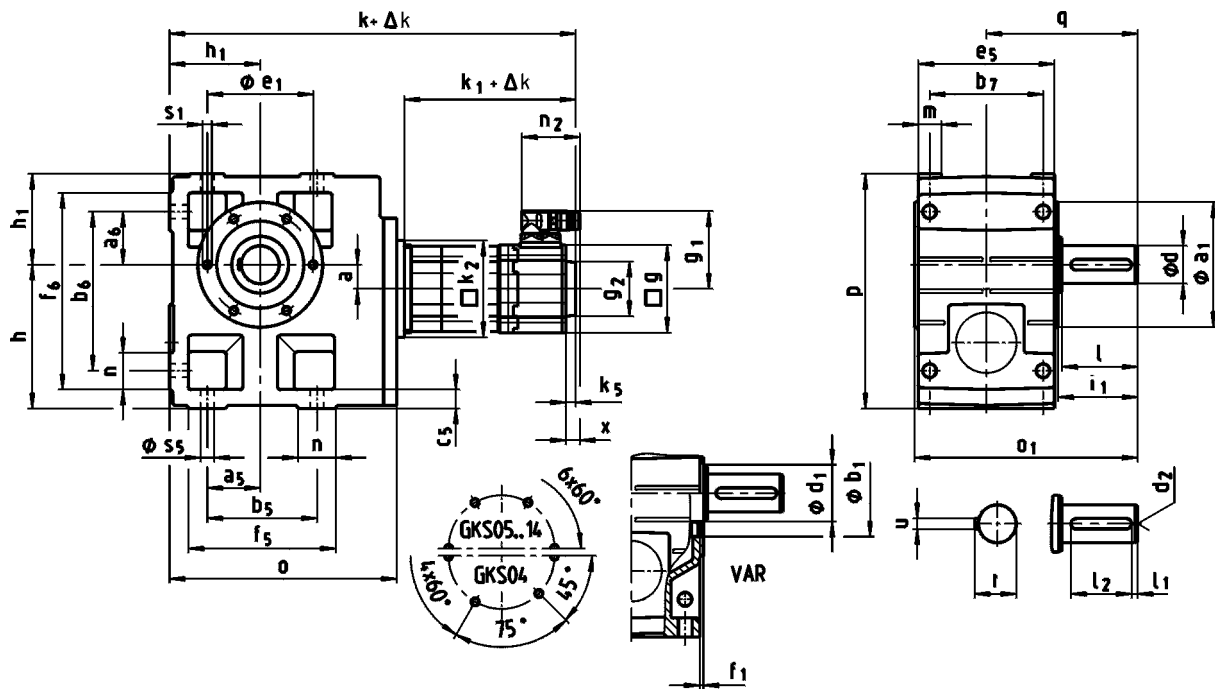

GKS□□-3S V□R ... RSO

		06C C41	06F C41	06I C41	09D C41	09F C38	09H C41	09L C41	12D C20	12D C41	12H C15	12H C30	12H C35	12L C20	12L C41	
GKS04...	k	347	377	407	399	419	439	479								
GKS05...	k	367	397	427	419	439	459	499	436		476			516		
GKS06...	k	423	453	483	475	495	515	555	492		532			572		
GKS07...	k				531	551	571	611	548		588			628		
GKS09...	k								619		659			699		
...RSO B0 ¹⁾	Δk	0														
...RSO P□ ¹⁾	Δk	19				20										
...RSO	k_1	132	162	192	183	203	223	263	188		228			268		
	k_2	66			91								118	145 ²⁾		
	g	62			89								116			
	k_5	0			13								14			
	g_2	□ 62			Ø 67								Ø 72			
	g_1	76			90								105			
	n_2	64							78							
	x					21								18		

¹⁾ → 801 - SRS / SRM / ECN / EQN / EQI / C20

²⁾ GKS05: 12DC20 ... 12LC41

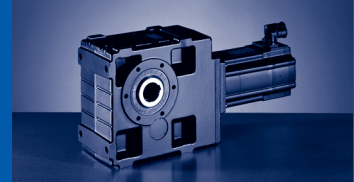

GKS□□-3S V□R ... RSO

		14D C15	14D C36	14H C15	14H C32	14L C15	14L C32	14P C14	14P C32	19F C14	19F C30	19J C14	19J C30	19P C14	19P C30				
GKS06...	k	508		548		588		628											
GKS07...	k	564		604		644		684		603		643		703					
GKS09...	k	635		675		715		755		674		714		774					
GKS11...	k	726		766		806		846		765		805		865					
GKS14...	k									864		904		964					
...RSO B0 ¹⁾	Δ k	0																	
...RSO P□ ¹⁾	Δ k	28						34						44					
	k ₁	201		241		281		321		220		260		320					
	k ₂	145						195											
	g	143						192											
...RSO	k ₅	24						15											
	g ₂	Ø 78																	
	g ₁	116				147		116		147		141		172		141		172	
	n ₂	78				94		78		94		78		94		78		94	
	x	16				38		16		38		16		36		16		36	

1) → 801 - SRS / SRM / ECN / EQN / EQI / C20

GKS□□-3S V□R

	o	o ₁	p	h	h ₁	a	q	a ₅	a ₆	b ₅	b ₆	b ₇	c ₅	e ₅	f ₅	f ₆	m	n	s ₅
GKS04...	203	163	171	100	71	20	107.5	45	45	110	119	85	14	105	132	141	21	22	9
GKS05...	232	197	205	125	80	23	130	47.5	47.5	115	140	105	17	127	144	169		29	11
GKS06...	291	236	250	150	100	28	160	60	60	155	170	120	20	145	191	206	23	36	14
GKS07...	354	296	310	190	120	34	200	70	70	190	210	150	25	180	235	255	28	45	18
GKS09...	429	356	386	236	150	41	240	90	90	240	266	185	30	222	300	326	37	60	22
GKS11...	527	445	485	300	185	54	305	105	105	290	325	225	40	270	363	398	43	73	26
GKS14...	636	544	605	375	230	67	375	135	135	360	415	275	50	328	442	497	52	82	33

	d	l	d ₁	l ₁	l ₂	d ₂	u	t	a ₁	b ₁	e ₁	f ₁	i ₁	s ₁
										H7				
GKS04...	25	50	45	4	40	M10	8	28	105	75	90	3	52.5	M6x12
GKS05...	30	60	50	6	45			33	118	80	100	4	64	M8x15
GKS06...	40	80	65	7	63	M16	12	43	140	100	120		85	M10x16
GKS07...	50	100	75	8	80			14	53.5	165	115	140	5	105
GKS09...	60	120	95		100	M20	18	64	205	145	175	6	125	M16x24
GKS11...	80	160	105	15	125			22	85	240	140		205	166
GKS14...	100	200	135	18	160	M24	28	106	290	170	250	207	M24x35	

d ≤ 50 mm: k6; d > 50 mm: m6

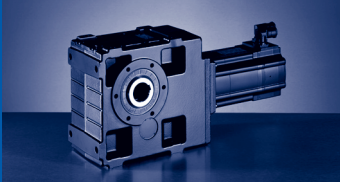

GKS [mm]

GKS□□-3S (MCS)

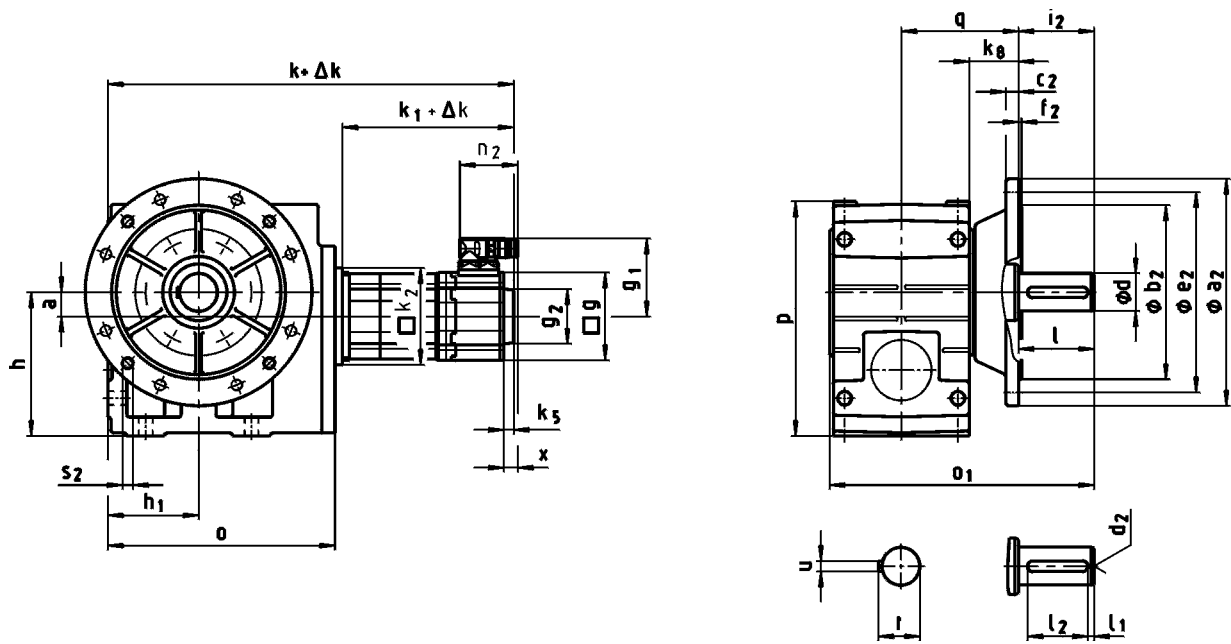

GKS□□-3S VAK ... RSO

		06C C41	06F C41	06I C41	09D C41	09F C38	09H C41	09L C41	12D C20	12D C41	12H C15	12H C30	12H C35	12L C20	12L C41
GKS04...	k	347	377	407	399	419	439	479							
GKS05...	k	367	397	427	419	439	459	499	436			476			516
GKS06...	k	423	453	483	475	495	515	555	492			532			572
GKS07...	k				531	551	571	611	548			588			628
GKS09...	k								619			659			699
...RSO B0 ¹⁾	Δk	0													
...RSO P□ ¹⁾	Δk	19				20									
	k_1	132	162	192	183	203	223	263	188		228		268		
	k_2	66			91						118		145 ²⁾		
	g	62			89						116				
...RSO	k_5	0			13						14				
	g_2	□ 62			Ø 67						Ø 72				
	g_1	76			90						105				
	n_2	64							78						
	x				21						18				

1) → 801 - SRS / SRM / ECN / EQN / EQI / C20

2) GKS05: 12DC20 ... 12LC41

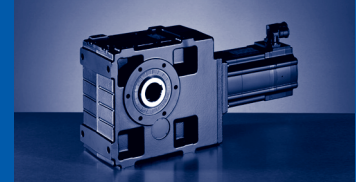

GKS□□-3S VAK ... RSO

		14D C15	14D C36	14H C15	14H C32	14L C15	14L C32	14P C14	14P C32	19F C14	19F C30	19J C14	19J C30	19P C14	19P C30	
GKS06...	k	508		548		588		628								
GKS07...	k	564		604		644		684		603		643		703		
GKS09...	k	635		675		715		755		674		714		774		
GKS11...	k	726		766		806		846		765		805		865		
GKS14...	k									864		904		964		
...RSO B0 ¹⁾	Δ k	0														
...RSO P□ ¹⁾	Δ k	28						34			44					
	k ₁	201		241		281		321		220		260		320		
	k ₂	145						195								
	g	143						192								
...RSO	k ₅	24						15								
	g ₂	Ø 78														
	g ₁	116				147		116	147	141	172	141	172	141	172	
	n ₂	78				94		78	94	78	94	78	94	78	94	
	x	16				38		16	38	16	36	16	36	16	36	

¹⁾ → 801 - SRS / SRM / ECN / EQN / EQI / C20

GKS□□-3S VAK

	o	o ₁	p	h	h ₁	a	q	k ₈
GKS04...	203	196	171	100	71	20	91	39
GKS05...	232	230	205	125	80	23	103.5	40
GKS06...	291	277	250	150	100	28	121.5	49
GKS07...	354	351	310	190	120	34	155.5	66
GKS09...	429	416	386	236	150	41	180.5	70
GKS11...	527	505	485	300	185	54	205.5	71
GKS14...	636	604	605	375	230	67	235.5	72

	d	l	l ₁	l ₂	d ₂	u	t	a ₂	b ₂	c ₂	e ₂	f ₂	i ₂	s ₂
GKS04...	25	50	4	40	M10	8	28	160	110	10	130	3.5	50	4 x 9
GKS05...	30	60	6	45			33	200	130	12	165		60	4 x 11
GKS06...	40	80	7	63	M16	14	43	250	180	15	215	4	80	4 x 14
GKS07...	50	100	8	80			53.5						300	
GKS09...	60	120		100	M20	22	64	350	250	18	300	5	120	4 x 17.5
GKS11...	80	160	15	125			85	400	300	20	350		160	
GKS14...	100	200	18	160	M24	28	106	450	350	22	400	5	200	8 x 17.5

d ≤ 50 mm: k6; d > 50 mm: m6

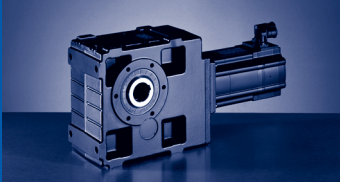

GKS [mm]

GKS□□-4S (MCS)

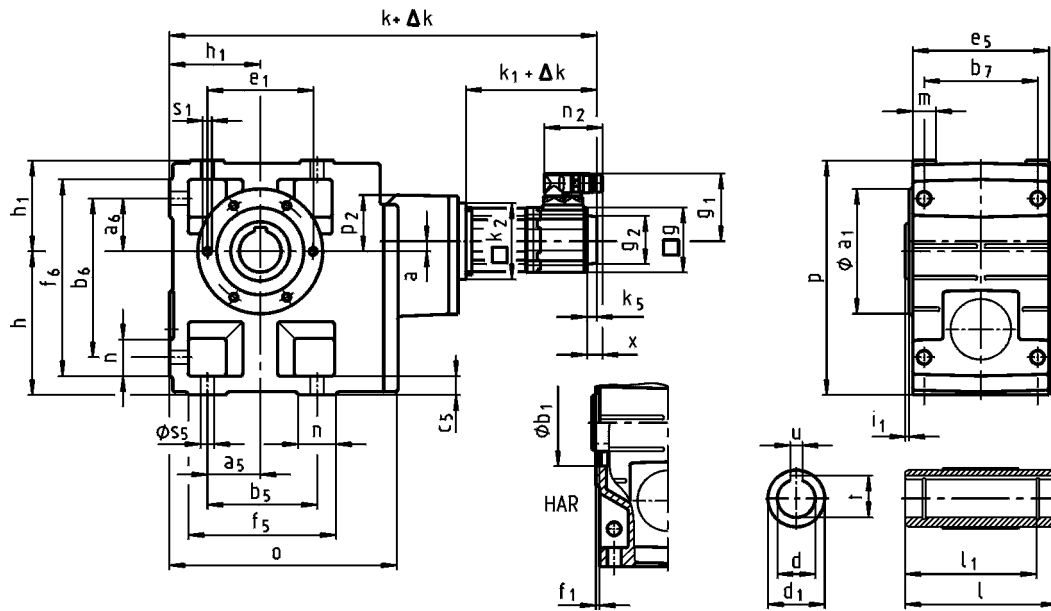

GKS□□-4S H□R ... RSO

		06C C41	06F C41	06I C41	09D C41	09F C38	09H C41	09L C41	12D C20	12D C41	12H C15	12H C30	12H C35	12L C20	12L C41		
GKS05...	k	443	473	503	496	516	536	576									
GKS06...	k	516	546	576	569	589	609	649									
GKS07...	k	583	613	643	636	656	676	716	653		693			733			
GKS09...	k	672	702	732	725	745	765	805	742		782			822			
GKS11...	k				835	855	875	915	852		892			932			
GKS14...	k								985		1025			1065			
...RSO B0 ¹⁾	Δk	0															
...RSO P□ ¹⁾	Δk	19				20											
	k_1	132	162	192	183	203	223	263	188		228			268			
	k_2	66			91						118	145 ²⁾					
	g	62			89						116						
...RSO	k_5	0			13						14						
	g_2	□ 62			Ø 67						Ø 72						
	g_1	76			90						105						
	n_2	64								78							
	x	21												18			

1) → 801 - SRS / SRM / ECN / EQN / EQI / C20

2) GKS07: 12DC20 ... 12LC41

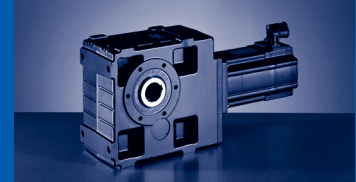

GKS□□-4S H□R ... RSO

		14D C15	14D C36	14H C15	14H C32	14L C15	14L C32	14P C14	14P C32	19F C14	19F C30	19J C14	19J C30	19P C14	19P C30				
GKS09...	k	757		797		837		877											
GKS11...	k	867		907		947		987		906		946		1006					
GKS14...	k	1000		1040		1080		1120		1039		1079		1139					
...RSO B0 ¹⁾	Δ k	0																	
...RSO P□ ¹⁾	Δ k	28						34			44								
	k ₁	201		241		281		321		220		260		320					
	k ₂	145						195											
	g	143						192											
...RSO	k ₅	24						15											
	g ₂	Ø 78																	
	g ₁	116				147		116		147		141		172		141		172	
	n ₂	78				94		78		94		78		94		78		94	
	x	16				38		16		38		16		36		16		36	

¹⁾ →  801 - SRS / SRM / ECN / EQN / EQI / C20

GKS□□-4S H□R

	o	p	p ₂	h	h ₁	a	a ₅	a ₆	b ₅	b ₆	b ₇	c ₅	e ₅	f ₅	f ₆	m	n	s ₅
GKS05...	226	205	65	125	80	13	47.5	47.5	115	140	105	17	127	144	169	21	29	11
GKS06...	288	250	61	150	100	8	60	60	155	170	120	20	145	191	206	23	36	14
GKS07...	351	310	72	190	120	11	70	70	190	210	150	25	180	235	255	28	45	18
GKS09...	426	386	92	236	150	15	90	90	240	266	185	30	222	300	326	37	60	22
GKS11...	523	485	112	300	185	16	105	105	290	325	225	40	270	363	398	43	73	26
GKS14...	632	605	139	375	230	22	135	135	360	415	275	50	328	442	497	52	82	33

	d	l	d ₁	l ₁	u	t	a ₁	b ₁	e ₁	f ₁	i ₁	s ₁	
	H7				JS9	+0,2		H7				6x60°	
GKS05...	30	140	50	124	8	33.3	118	80	100	4	4	M8x15	
	35				10	38.3							
GKS06...	40	160	65	140	12	43.3	140	100	120		5	5	M10x16
	45				14	48.8							
GKS07...	50	200	75	175	14	53.8	165	115	140	6	6	M12x18	
	55				16	59.3							
GKS09...	60	240	95	210	18	64.4	205	145	175	7	7	M16x24	
	70				20	74.9							
GKS11...	80	290	105	250	22	85.4	240	140	205	8	8	M20x32	
	80				22	85.4							
GKS14...	100	350	135	305	28	106.4	290	170	250	9	9	M24x35	

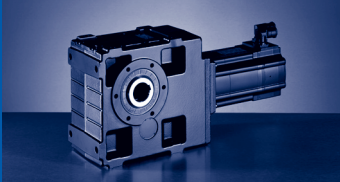

GKS [mm]

GKS□□-4S (MCS)

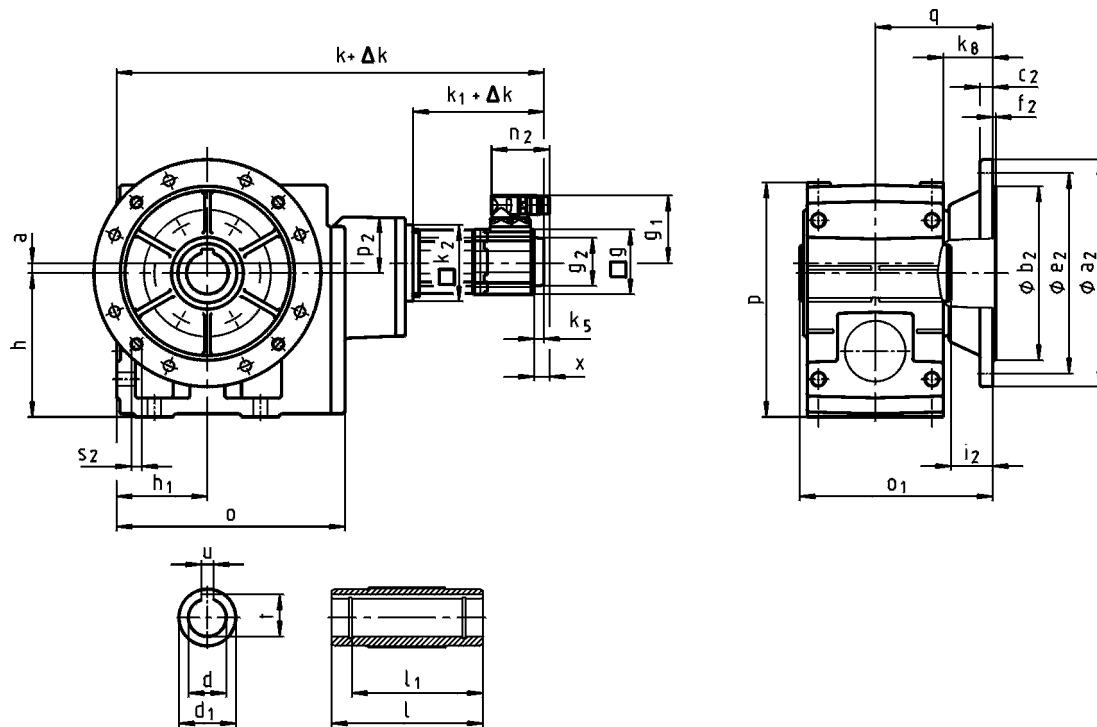

GKS□□-4S HAK ... RSO

		06C C41	06F C41	06I C41	09D C41	09F C38	09H C41	09L C41	12D C20	12D C41	12H C15	12H C30	12H C35	12L C20	12L C41	
GKS05...	k	443	473	503	496	516	536	576								
GKS06...	k	516	546	576	569	589	609	649								
GKS07...	k	583	613	643	636	656	676	716	653		693			733		
GKS09...	k	672	702	732	725	745	765	805	742		782			822		
GKS11...	k				835	855	875	915	852		892			932		
GKS14...	k								985		1025			1065		
...RSO B0 ¹⁾	Δk	0														
...RSO P□ ¹⁾	Δk	19				20										
	k_1	132	162	192	183	203	223	263	188		228			268		
	k_2	66			91						118	145 ²⁾				
...RSO	g	62			89						116					
	k_5	0			13						14					
	g_2	□ 62			Ø 67						Ø 72					
	g_1	76			90						105					
	n_2	64								78						
	x	21											18			

¹⁾ → 801 - SRS / SRM / ECN / EQN / EQI / C20

²⁾ GKS07: 12DC20 ... 12LC41

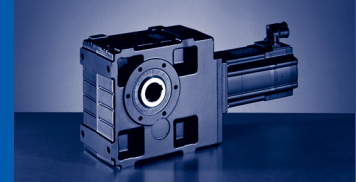

GKS□□-4S HAK ... RSO

		14D C15	14D C36	14H C15	14H C32	14L C15	14L C32	14P C14	14P C32	19F C14	19F C30	19J C14	19J C30	19P C14	19P C30				
GKS09...	k	757		797		837		877											
GKS11...	k	867		907		947		987		906		946		1006					
GKS14...	k	1000		1040		1080		1120		1039		1079		1139					
...RSO B0 ¹⁾	Δ k	0																	
...RSO P□ ¹⁾	Δ k	28						34			44								
	k ₁	201		241		281		321		220		260		320					
	k ₂	145						195											
	g	143						192											
...RSO	k ₅	24						15											
	g ₂	Ø 78																	
	g ₁	116				147		116		147		141		172		141		172	
	n ₂	78				94		78		94		78		94		78		94	
	x	16				38		16		38		16		36		16		36	

¹⁾ → 801 - SRS / SRM / ECN / EQN / EQI / C20

GKS□□-4S HAK

	o	o ₁	p	p ₂	h	h ₁	a	q	k _g
GKS05...	226	174	205	65	125	80	13	103.5	40
GKS06...	288	203 ²⁾ 202 ³⁾	250	61	150	100	8	122.5 ²⁾ 121.5 ³⁾	50 ²⁾ 49 ³⁾
GKS07...	351	256	310	72	190	120	11	155.5	66
GKS09...	426	301	386	92	236	150	15	180.5	70
GKS11...	523	351	485	112	300	185	16	205.5	71
GKS14...	632	411	605	139	375	230	22	235.5	72

²⁾ a₂ = 200

³⁾ a₂ = 250

	d	l	d ₁	l ₁	u	t	a ₂	b ₂	c ₂	e ₂	f ₂	i ₂	s ₂
	H7				JS9	+0,2		j7					
GKS05...	30	140	50	124	8	33.3	200	130	12	165	3.5	33.5	4 x 11
	35				10	38.3							
GKS06...	40	160	65	140	12	43.3	250	180	15	215	4	42.5	4 x 14
	45				14	48.8						41.5	
GKS07...	50	200	75	175	14	53.8	300	230	17	265	4	55.5	4 x 17.5
	55				16	59.3							
GKS09...	60	240	95	210	18	64.4	350	250	18	300	5	60.5	8 x 17.5
	70				20	74.9							
GKS11...	80	290	105	250	22	85.4	450	350	22	400	5	60.5	8 x 17.5
	80				22	85.4							
GKS14...	100	350	135	305	28	106.4							

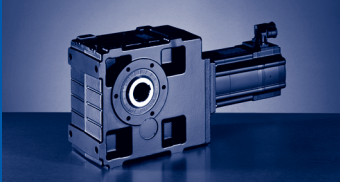

GKS [mm]

GKS□□-4S (MCS)

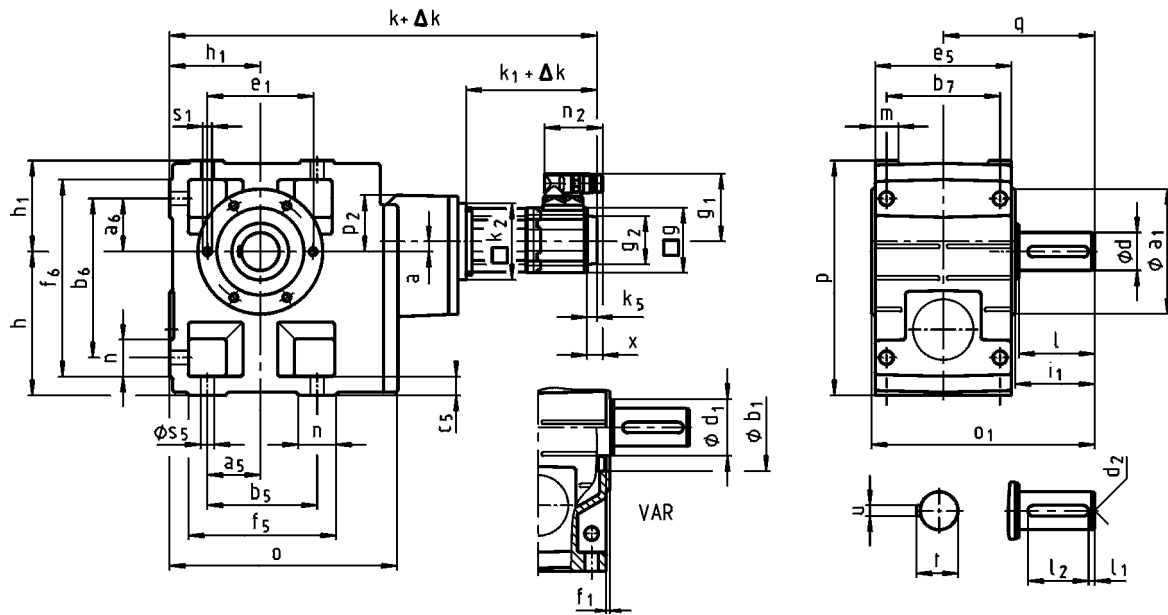

GKS□□-4S V□R ... RSO

		06C C41	06F C41	06I C41	09D C41	09F C38	09H C41	09L C41	12D C20	12D C41	12H C15	12H C30	12H C35	12L C20	12L C41		
GKS05...	k	443	473	503	496	516	536	576									
GKS06...	k	516	546	576	569	589	609	649									
GKS07...	k	583	613	643	636	656	676	716	653		693			733			
GKS09...	k	672	702	732	725	745	765	805	742		782			822			
GKS11...	k				835	855	875	915	852		892			932			
GKS14...	k								985		1025			1065			
...RSO B0 ¹⁾	Δk	0															
...RSO P□ ¹⁾	Δk	19								20							
	k_1	132	162	192	183	203	223	263	188		228			268			
	k_2	66			91								118 145 ²⁾				
	g	62			89								116				
...RSO	k_5	0			13								14				
	g_2	□ 62			Ø 67								Ø 72				
	g_1	76			90								105				
	n_2	64							78								
	x				21								18				

¹⁾ → 801 - SRS / SRM / ECN / EQN / EQI / C20

²⁾ GKS07: 12DC20 ... 12LC41

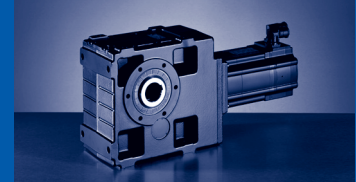

GKS□□-4S V□R ... RSO

		14D C15	14D C36	14H C15	14H C32	14L C15	14L C32	14P C14	14P C32	19F C14	19F C30	19J C14	19J C30	19P C14	19P C30				
GKS09...	k	757		797		837		877											
GKS11...	k	867		907		947		987		906		946		1006					
GKS14...	k	1000		1040		1080		1120		1039		1079		1139					
...RSO B0 ¹⁾	Δ k	0																	
...RSO P□ ¹⁾	Δ k	28						34			44								
	k ₁	201		241		281		321		220		260		320					
	k ₂	145						195											
	g	143						192											
...RSO	k ₅	24						15											
	g ₂	Ø 78																	
	g ₁	116				147		116		147		141		172		141		172	
	n ₂	78				94		78		94		78		94		78		94	
	x	16				38		16		38		16		36		16		36	

¹⁾ → 801 - SRS / SRM / ECN / EQN / EQI / C20

GKS□□-4S V□R

	o	o ₁	p	p ₂	h	h ₁	a	q	a ₅	a ₆	b ₅	b ₆	b ₇	c ₅	e ₅	f ₅	f ₆	m	n	s ₅
GKS05...	226	197	205	65	125	80	13	130	47.5	47.5	115	140	105	17	127	144	169	21	29	11
GKS06...	288	236	250	61	150	100	8	160	60	60	155	170	120	20	145	191	206	23	36	14
GKS07...	351	296	310	72	190	120	11	200	70	70	190	210	150	25	180	235	255	28	45	18
GKS09...	426	356	386	92	236	150	15	240	90	90	240	266	185	30	222	300	326	37	60	22
GKS11...	523	445	485	112	300	185	16	305	105	105	290	325	225	40	270	363	398	43	73	26
GKS14...	632	544	605	139	375	230	22	375	135	135	360	415	275	50	328	442	497	52	82	33

	d	l	d ₁	l ₁	l ₂	d ₂	u	t	a ₁	b ₁	e ₁	f ₁	i ₁	s ₁
										H7				6x60°
GKS05...	30	60	50	6	45	M10	8	33	118	80	100	4	64	M8x15
GKS06...	40	80	65	7	63	M16	12	43	140	100	120		85	M10x16
GKS07...	50	100	75	8	80		M20	14	53.5	165	115	140	5	105
GKS09...	60	120	95		100	18		64	205	145	175	6	125	M16x24
GKS11...	80	160	105	15	125	22	85	240	140	205	166		M20x32	
GKS14...	100	200	135	18	160	M24	28	106	290	170	250		207	M24x35

d ≤ 50 mm: k6; d > 50 mm: m6

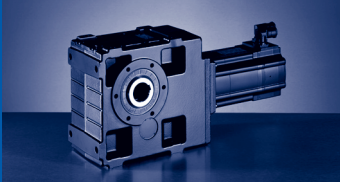

GKS [mm]

GKS□□-4S (MCS)

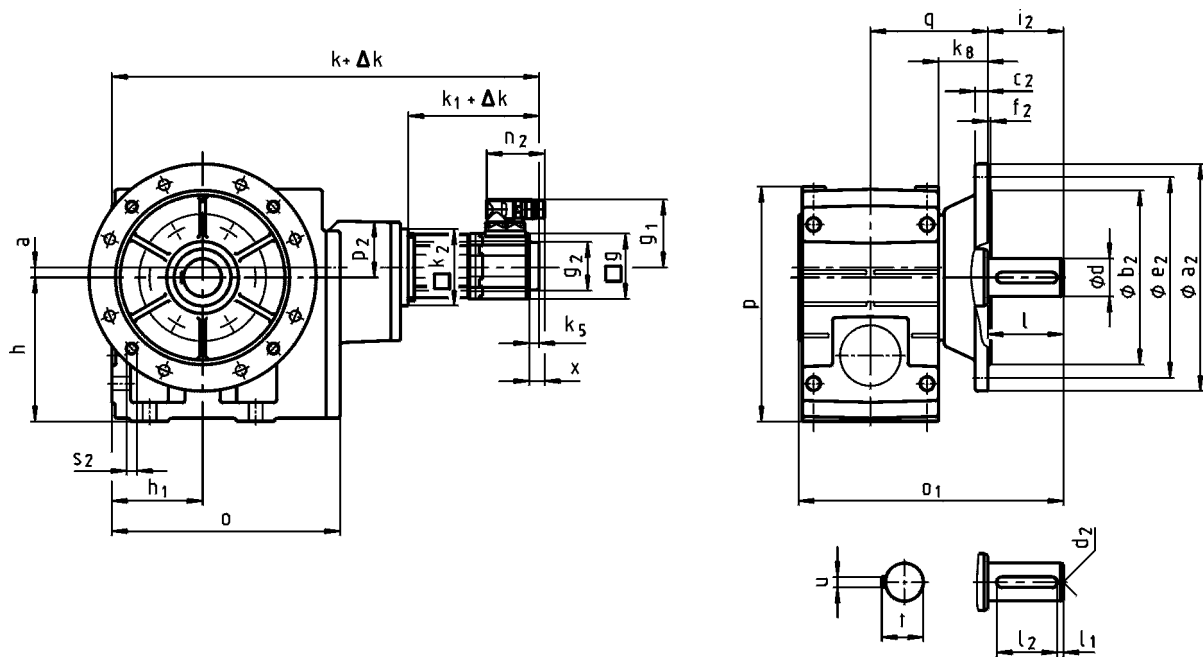

GKS□□-4S VAK ... RSO

		06C C41	06F C41	06I C41	09D C41	09F C38	09H C41	09L C41	12D C20	12D C41	12H C15	12H C30	12H C35	12L C20	12L C41	
GKS05...	k	443	473	503	496	516	536	576								
GKS06...	k	516	546	576	569	589	609	649								
GKS07...	k	583	613	643	636	656	676	716	653		693			733		
GKS09...	k	672	702	732	725	745	765	805	742		782			822		
GKS11...	k				835	855	875	915	852		892			932		
GKS14...	k								985		1025			1065		
...RSO B0 ¹⁾	Δk	0														
...RSO P□ ¹⁾	Δk	19				20										
	k_1	132	162	192	183	203	223	263	188		228			268		
	k_2	66			91						118		145 ²⁾			
	g	62			89						116					
...RSO	k_5	0			13						14					
	g_2	□ 62			Ø 67						Ø 72					
	g_1	76			90						105					
	n_2	64							78							
	x	21										18				

1) → 801 - SRS / SRM / ECN / EQN / EQI / C20

2) GKS07: 12DC20 ... 12LC41

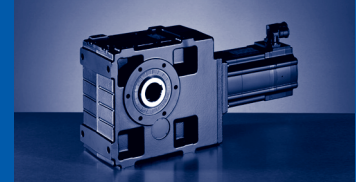

GKS□□-4S VAK ... RSO

		14D C15	14D C36	14H C15	14H C32	14L C15	14L C32	14P C14	14P C32	19F C14	19F C30	19J C14	19J C30	19P C14	19P C30	
GKS09...	k	757		797		837		877								
GKS11...	k	867		907		947		987		906		946		1006		
GKS14...	k	1000		1040		1080		1120		1039		1079		1139		
...RSO B0 ¹⁾	Δ k	0														
...RSO P□ ¹⁾	Δ k	28						34			44					
	k ₁	201		241		281		321		220		260		320		
	k ₂	145						195								
	g	143						192								
...RSO	k ₅	24						15								
	g ₂	Ø 78														
	g ₁	116				147	116	147	141	172	141	172	141	172	141	172
	n ₂	78				94	78	94	78	94	78	94	78	94	78	94
	x	16				38	16	38	16	36	16	36	16	36	16	36

1) → 801 - SRS / SRM / ECN / EQN / EQI / C20

GKS□□-4S VAK

	o	o ₁	p	p ₂	h	h ₁	a	q	k _g
GKS05...	226	230	205	65	125	80	13	103.5	40
GKS06...	288	277	250	61	150	100	8	121.5	49
GKS07...	351	351	310	72	190	120	11	155.5	66
GKS09...	426	416	386	92	236	150	15	180.5	70
GKS11...	523	505	485	112	300	185	16	205.5	71
GKS14...	632	604	605	139	375	230	22	235.5	72

	d	l	l ₁	l ₂	d ₂	u	t	a ₂	b ₂	c ₂	e ₂	f ₂	i ₂	s ₂
GKS05...	30	60	6	45	M10	8	33	200	130	12	165	3.5	60	4 x 11
GKS06...	40	80	7	63	M16	12	43	250	180	15	215	4	80	4 x 14
GKS07...	50	100	8	80		14	53.5	300	230	17	265		100	
GKS09...	60	120		100	M20	18	64	350	250	18	300	5	120	4 x 17.5
GKS11...	80	160	15	125		22	85	400	300	20	350		160	
GKS14...	100	200	18	160		M24	28	106	450	350	22		400	200

d ≤ 50 mm: k6; d > 50 mm: m6

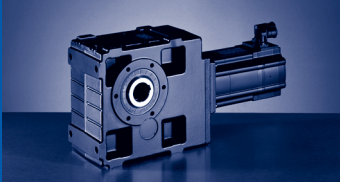

GKS [mm]

GKS□□-3A (MCA)

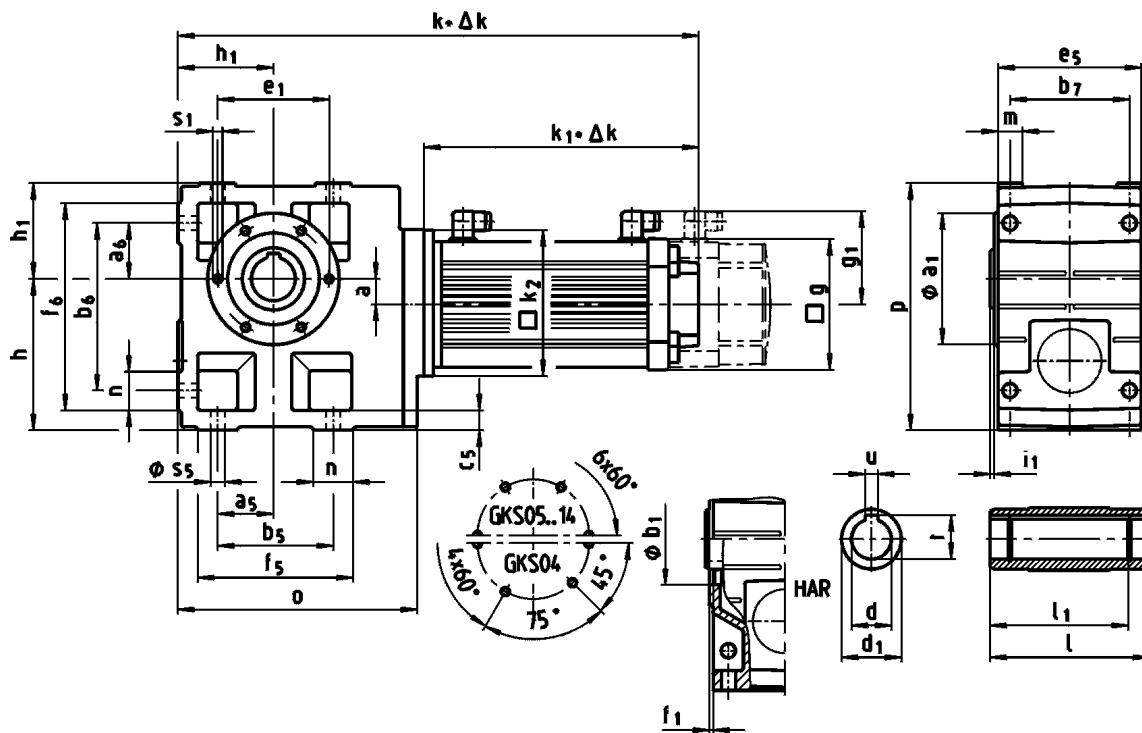

GKS□□-3A H□R ... RSO

		10I C40 ...S00	13I C41 ...S00	13I C34 ...F10	14L C20 ...S00	14L C41 ...S00	14L C16 ...F10	14L C35 ...F10	17N C23 ...S00	17N C41 ...S00
GKS04...	k	475	483	551						
GKS05...	k	495	503	571	553		615			
GKS06...	k	551	559	627	609		671		648	
GKS07...	k	607	615	683	665		727		704	
GKS09...	k				736		798		775	
GKS11...	k				827		889		866	
...RSO B0 ¹⁾	Δ k	0								
...RSO P□ ¹⁾	Δ k	25	35			33			35	
	k ₁	258	267	335	307		369		346	
	k ₂	145				180				
	g	102	131			142			165	
	g ₁	90	102			109			118	

¹⁾ → 803 - SRS / SRM / ECN / EQN / EQI / S20 / T20 / CDD

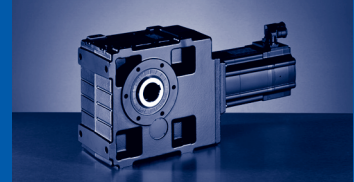

GKS□□-3A H□R ... RSO

		17N C17 ...F10	17N C35 ...F10	19S C23 ...S00	19S C42 ...S00	19S C17 ...F10	19S C35 ...F10	21X C25 ...S00	21X C42 ...S00	21X C17 ...F10	21X C35 ...F10		
GKS06...	k	737											
GKS07...	k	793		773		870		851		947			
GKS09...	k	864		844		941		922		1018			
GKS11...	k	955		935		1032		1013		1109			
GKS14...	k			1034		1131		1112		1208			
...RSO B0 ¹⁾	Δ k	0											
...RSO P□ ¹⁾	Δ k	35			38			42					
	k ₁	435		408		505		479		575			
	k ₂	180				222				265			
	g	165				192				214			
	g ₁	118				161				172			

¹⁾ → 803 - SRS / SRM / ECN / EQN / EQI / S20 / T20 / CDD

GKS□□-3A H□R

	o	p	h	h ₁	a	a ₅	a ₆	b ₅	b ₆	b ₇	c ₅	e ₅	f ₅	f ₆	m	n	s ₅
GKS04...	203	171	100	71	20	45	45	110	119	85	14	105	132	141	21	22	9
GKS05...	232	205	125	80	23	47.5	47.5	115	140	105	17	127	144	169		29	11
GKS06...	291	250	150	100	28	60	60	155	170	120	20	145	191	206	23	36	14
GKS07...	354	310	190	120	34	70	70	190	210	150	25	180	235	255	28	45	18
GKS09...	429	386	236	150	41	90	90	240	266	185	30	222	300	326	37	60	22
GKS11...	527	485	300	185	54	105	105	290	325	225	40	270	363	398	43	73	26
GKS14...	636	605	375	230	67	135	135	360	415	275	50	328	442	497	52	82	33

	d	l	d ₁	l ₁	u	t	a ₁	b ₁	e ₁	f ₁	i ₁	s ₁
	H7				JS9	+0,2		H7				
GKS04...	25	115	45	100	8	28.3	105	75	90	3	2.5	M6x12
	30					33.3						
GKS05...	35	140	50	124	10	38.3	118	80	100	4	4	M8x15
	40					43.3						
GKS06...	45	160	65	140	14	48.8	140	100	120	5	5	M10x16
	50					53.8						
GKS07...	55	200	75	175	16	59.3	165	115	140	6	6	M12x18
	60					64.4						
GKS09...	70	240	95	210	20	74.9	205	145	175	7	7	M16x24
	80					85.4						
GKS11...	80	290	105	250	22	85.4	240	140	205	8	8	M20x32
	100					106.4						
GKS14...	100	350	135	305	28	106.4	290	170	250	9	9	M24x35

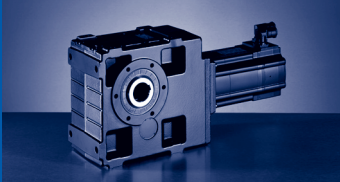

GKS [mm]

GKS□□-3A (MCA)

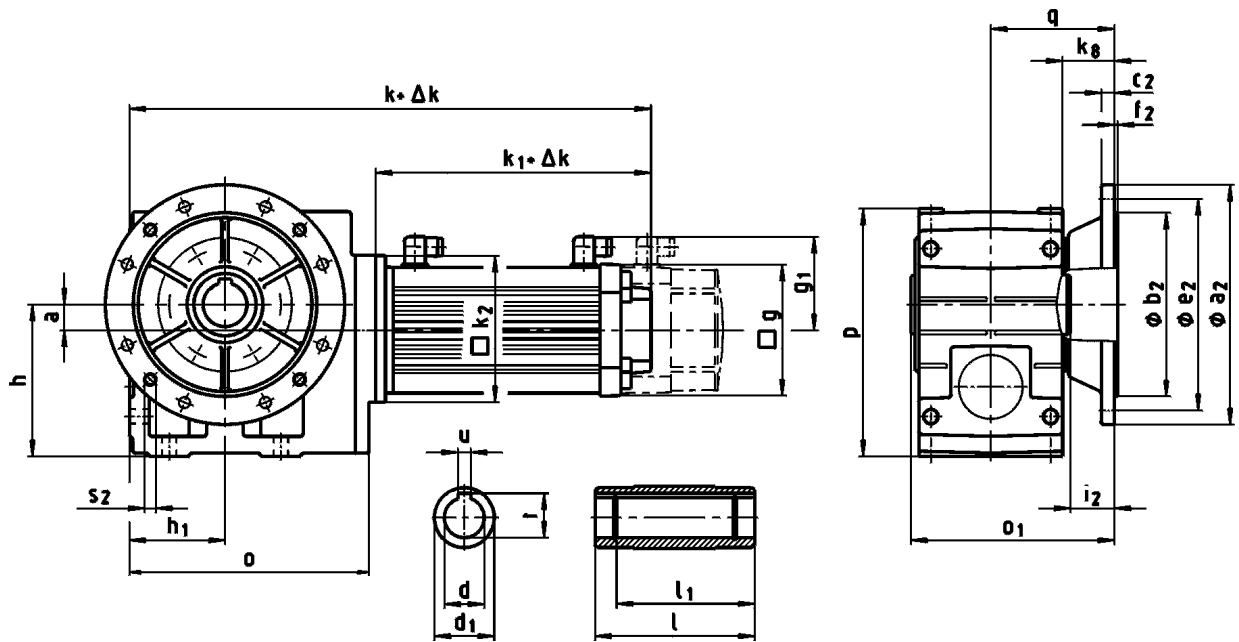

GKS□□-3A HAK ... RSO

		10L C40 ...S00	13L C41 ...S00	13L C34 ...F10	14L C20 ...S00	14L C41 ...S00	14L C16 ...F10	14L C35 ...F10	17N C23 ...S00	17N C41 ...S00
GKS04...	k	475	483	551						
GKS05...	k	495	503	571	553		615			
GKS06...	k	551	559	627	609		671		648	
GKS07...	k	607	615	683	665		727		704	
GKS09...	k				736		798		775	
GKS11...	k				827		889		866	
...RSO B0 ¹⁾	Δk	0								
...RSO P□ ¹⁾	Δk	25	35			33			35	
	k_1	258	267	335	307		369		346	
	k_2	145				180				
	g	102	131			142			165	
	g_1	90	102			109			118	

¹⁾ → 803 - SRS / SRM / ECN / EQN / EQI / S20 / T20 / CDD

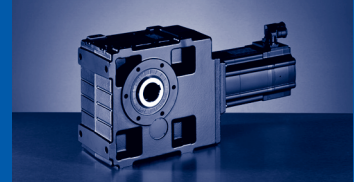

GKS□□-3A HAK ... RSO

		17N C17 ...F10	17N C35 ...F10	19S C23 ...S00	19S C42 ...S00	19S C17 ...F10	19S C35 ...F10	21X C25 ...S00	21X C42 ...S00	21X C17 ...F10	21X C35 ...F10		
GKS06...	k	737											
GKS07...	k	793		773		870		851		947			
GKS09...	k	864		844		941		922		1018			
GKS11...	k	955		935		1032		1013		1109			
GKS14...	k			1034		1131		1112		1208			
...RSO B0 ¹⁾	Δ k	0											
...RSO P□ ¹⁾	Δ k	35			38			42					
	k ₁	435		408		505		479		575			
	k ₂	180				222				265			
	g	165				192				214			
	g ₁	118				161				172			

¹⁾ → 803 - SRS / SRM / ECN / EQN / EQI / S20 / T20 / CDD

GKS□□-3A HAK

	o	o ₁	p	h	h ₁	a	q	k ₈
GKS04...	203	149	171	100	71	20	91	39
GKS05...	232	174	205	125	80	23	103.5	40
GKS06...	291	203 ²⁾ 202 ³⁾	250	150	100	28	122.5 ²⁾ 121.5 ³⁾	50 ²⁾ 49 ³⁾
GKS07...	354	256	310	190	120	34	155.5	66
GKS09...	429	301	386	236	150	41	180.5	70
GKS11...	527	351	485	300	185	54	205.5	71
GKS14...	636	411	605	375	230	67	235.5	72

²⁾ a₂ = 200

³⁾ a₂ = 250

	d	l	d ₁	l ₁	u	t	a ₂	b ₂	c ₂	e ₂	f ₂	i ₂	s ₂
	H7				JS9	+0,2		j7					
GKS04...	25	115	45	100	8	28.3	160	110	10	130	3.5	33.5	4 x 9
	30					33.3							
GKS05...	35	140	50	124	10	38.3	200	130	12	165	4	42.5	4 x 11
	40					43.3							
GKS06...	45	160	65	140	14	48.8	250	180	15	215	4	41.5	4 x 14
	50					53.8							
GKS07...	55	200	75	175	16	59.3	300	230	17	265	5	55.5	4 x 17.5
	60					64.4							
GKS09...	70	240	95	210	20	74.9	350	250	18	300	5	60.5	4 x 17.5
	80					85.4							
GKS11...	80	290	105	250	22	85.4	400	300	20	350	5	60.5	4 x 17.5
	100					106.4							
GKS14...	100	350	135	305	28	106.4	450	350	22	400	5	60.5	8 x 17.5

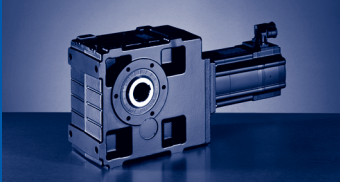

GKS [mm]

GKS□□-3A (MCA)

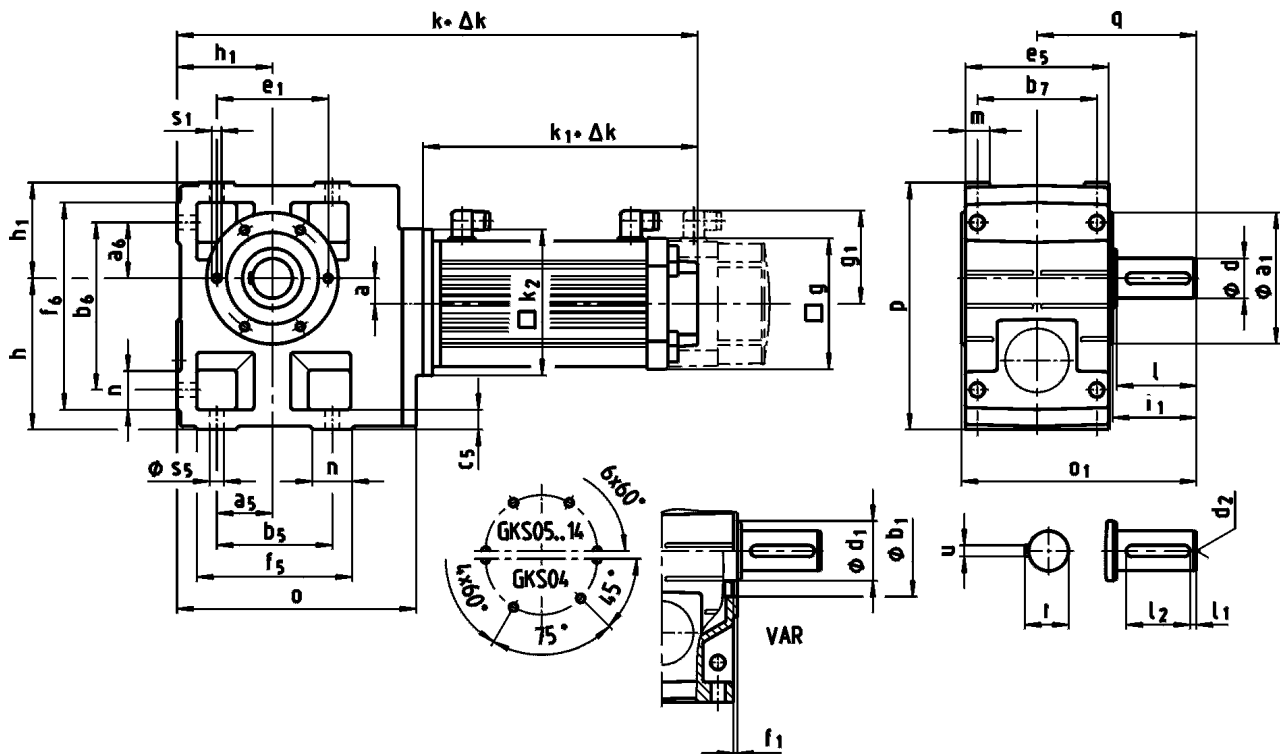

GKS□□-3A V□R ... RSO

		10I C40 ...S00	13I C41 ...S00	13I C34 ...F10	14L C20 ...S00	14L C41 ...S00	14L C16 ...F10	14L C35 ...F10	17N C23 ...S00	17N C41 ...S00
GKS04...	k	475	483	551						
GKS05...	k	495	503	571		553		615		
GKS06...	k	551	559	627		609		671		648
GKS07...	k	607	615	683		665		727		704
GKS09...	k					736		798		775
GKS11...	k					827		889		866
...RSO B0 ¹⁾	Δk					0				
...RSO P□ ¹⁾	Δk	25	35				33			35
	k ₁	258	267	335		307		369		346
	k ₂		145					180		
	g	102	131				142			165
	g ₁	90	102				109			118

¹⁾ → 803 - SRS / SRM / ECN / EQN / EQI / S20 / T20 / CDD

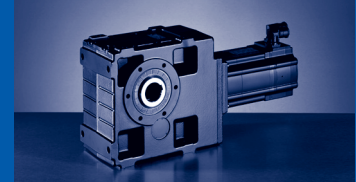

GKS□□-3A V□R ... RSO

		17N C17 ...F10	17N C35 ...F10	19S C23 ...S00	19S C42 ...S00	19S C17 ...F10	19S C35 ...F10	21X C25 ...S00	21X C42 ...S00	21X C17 ...F10	21X C35 ...F10		
GKS06...	k	737											
GKS07...	k	793		773		870		851		947			
GKS09...	k	864		844		941		922		1018			
GKS11...	k	955		935		1032		1013		1109			
GKS14...	k			1034		1131		1112		1208			
...RSO B0 ¹⁾	Δ k	0											
...RSO P□ ¹⁾	Δ k	35			38				42				
	k ₁	435		408		505		479		575			
	k ₂	180		222				265					
	g	165		192				214					
	g ₁	118		161				172					

¹⁾ → 803 - SRS / SRM / ECN / EQN / EQI / S20 / T20 / CDD

GKS□□-3A V□R

	o	o ₁	p	h	h ₁	a	q	a ₅	a ₆	b ₅	b ₆	b ₇	c ₅	e ₅	f ₅	f ₆	m	n	s ₅
GKS04...	203	163	171	100	71	20	107.5	45	45	110	119	85	14	105	132	141	21	22	9
GKS05...	232	197	205	125	80	23	130	47.5	47.5	115	140	105	17	127	144	169		29	11
GKS06...	291	236	250	150	100	28	160	60	60	155	170	120	20	145	191	206	23	36	14
GKS07...	354	296	310	190	120	34	200	70	70	190	210	150	25	180	235	255	28	45	18
GKS09...	429	356	386	236	150	41	240	90	90	240	266	185	30	222	300	326	37	60	22
GKS11...	527	445	485	300	185	54	305	105	105	290	325	225	40	270	363	398	43	73	26
GKS14...	636	544	605	375	230	67	375	135	135	360	415	275	50	328	442	497	52	82	33

	d	l	d ₁	l ₁	l ₂	d ₂	u	t	a ₁	b ₁	e ₁	f ₁	i ₁	s ₁
										H7				
GKS04...	25	50	45	4	40	M10	8	28	105	75	90	3	52.5	M6x12
GKS05...	30	60	50	6	45			33	118	80	100	4	64	M8x15
GKS06...	40	80	65	7	63	M16	14	43	140	100	120		85	M10x16
GKS07...	50	100	75	8	80			53.5	165	115	140	5	105	M12x18
GKS09...	60	120	95		100	M20	18	64	205	145	175	6	125	M16x24
GKS11...	80	160	105	125	22			85	240	140	205		166	M20x32
GKS14...	100	200	135	18	160	M24	28	106	290	170	250	207	M24x35	

d ≤ 50 mm: k6; d > 50 mm: m6

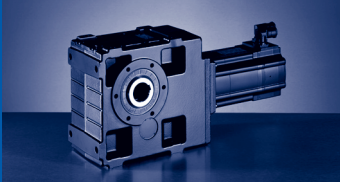

GKS [mm]

GKS□□-3A (MCA)

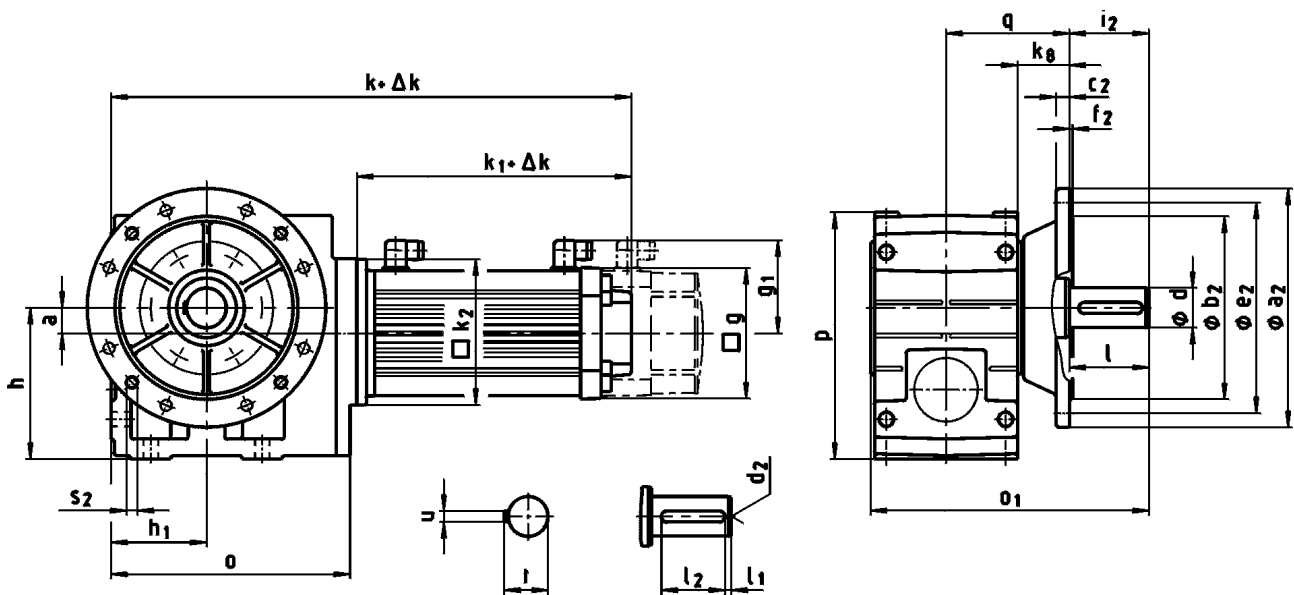

GKS□□-3A VAK ... RSO

		10I C40 ...S00	13I C41 ...S00	13I C34 ...F10	14L C20 ...S00	14L C41 ...S00	14L C16 ...F10	14L C35 ...F10	17N C23 ...S00	17N C41 ...S00
GKS04...	k	475	483	551				615		
GKS05...	k	495	503	571	553			615		
GKS06...	k	551	559	627	609			671	648	
GKS07...	k	607	615	683	665			727	704	
GKS09...	k				736			798	775	
GKS11...	k				827			889	866	
...RSO B0 ¹⁾	Δk	0								
...RSO P□ ¹⁾	Δk	25	35			33			35	
	k_1	258	267	335	307		369		346	
	k_2	145					180			
	g	102	131			142			165	
	g_1	90	102			109			118	

¹⁾ → 803 - SRS / SRM / ECN / EQN / EQI / S20 / T20 / CDD

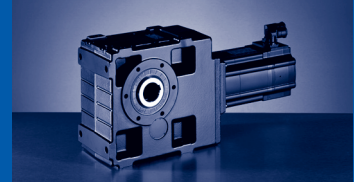

GKS□□-3A VAK ... RSO

		17N C17 ...F10	17N C35 ...F10	19S C23 ...S00	19S C42 ...S00	19S C17 ...F10	19S C35 ...F10	21X C25 ...S00	21X C42 ...S00	21X C17 ...F10	21X C35 ...F10		
GKS06...	k	737											
GKS07...	k	793		773		870		851		947			
GKS09...	k	864		844		941		922		1018			
GKS11...	k	955		935		1032		1013		1109			
GKS14...	k			1034		1131		1112		1208			
...RSO B0 ¹⁾	Δ k	0											
...RSO P□ ¹⁾	Δ k	35			38			42					
	k ₁	435		408		505		479		575			
	k ₂	180				222				265			
	g	165				192				214			
	g ₁	118				161				172			

¹⁾ → 803 - SRS / SRM / ECN / EQN / EQI / S20 / T20 / CDD

GKS□□-3A VAK

	o	o ₁	p	h	h ₁	a	q	k ₈
GKS04...	203	196	171	100	71	20	91	39
GKS05...	232	230	205	125	80	23	103.5	40
GKS06...	291	277	250	150	100	28	121.5	49
GKS07...	354	351	310	190	120	34	155.5	66
GKS09...	429	416	386	236	150	41	180.5	70
GKS11...	527	505	485	300	185	54	205.5	71
GKS14...	636	604	605	375	230	67	235.5	72

	d	l	l ₁	l ₂	d ₂	u	t	a ₂	b ₂	c ₂	e ₂	f ₂	i ₂	s ₂
									j7					
GKS04...	25	50	4	40	M10	8	28	160	110	10	130	3.5	50	4 x 9
GKS05...	30	60	6	45			33	200	130	12	165		60	4 x 11
GKS06...	40	80	7	63	M16	12	43	250	180	15	215	4	80	4 x 14
GKS07...	50	100	8	80			53.5	300	230	17	265		100	
GKS09...	60	120		100	M20	18	64	350	250	18	300	5	120	4 x 17.5
GKS11...	80	160	15	125			85	400	300	20	350		160	
GKS14...	100	200	18	160	M24	28	106	450	350	22	400		200	8 x 17.5

d ≤ 50 mm: k6; d > 50 mm: m6

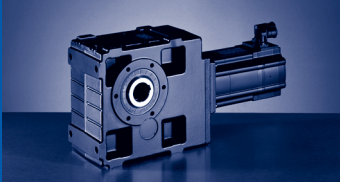

GKS [mm]

GKS□□-4A (MCA)

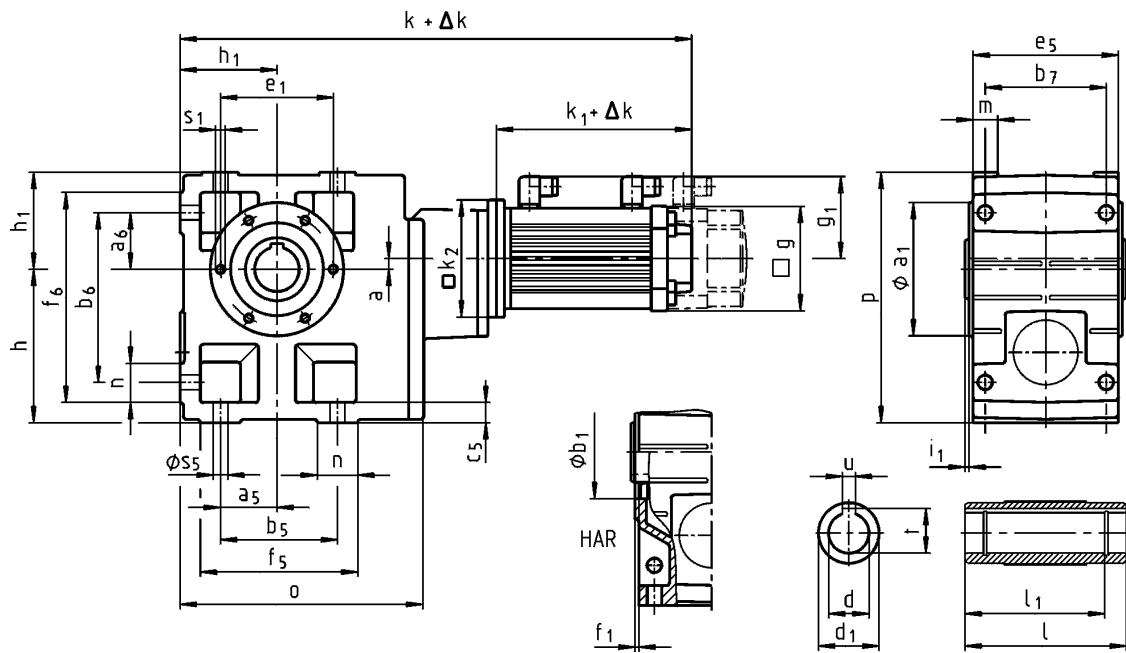

GKS□□-4A H□R ... RSO

		10I C40 ...S00	13I C41 ...S00	13I C34 ...F10	14L C20 ...S00	14L C41 ...S00	14L C16 ...F10	14L C35 ...F10	17N C23 ...S00	17N C41 ...S00
GKS05...	k	571	580	648						
GKS06...	k	644	653	721						
GKS07...	k	711	720	788	770		832			
GKS09...	k	800	809	877	859		921		898	
GKS11...	k	910	919	987	969		1031		1008	
GKS14...	k				1102		1164		1141	
...RSO B0 ¹⁾	Δk	0								
...RSO P□ ¹⁾	Δk	25	35			33			35	
	k_1	258	267	335	307		369		346	
	k_2	145					180			
	g	102	131			142			165	
	g_1	90	102			109			118	

¹⁾ → 803 - SRS / SRM / ECN / EQN / EQI / S20 / T20 / CDD

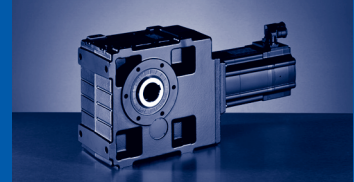

GKS□□-4A H□R ... RSO

		17N C17 ...F10	17N C35 ...F10	19S C23 ...S00	19S C42 ...S00	19S C17 ...F10	19S C35 ...F10	21X C25 ...S00	21X C42 ...S00	21X C17 ...F10	21X C35 ...F10		
GKS09...	k	987											
GKS11...	k	1097		1076		1173		1155		1251			
GKS14...	k	1230		1209		1306		1288		1384			
...RSO B0 ¹⁾	Δ k	0											
...RSO P□ ¹⁾	Δ k	35			38			42					
	k ₁	435		408		505		479		575			
	k ₂	180				222				265			
	g	165				192				214			
	g ₁	118				161				172			

1) → 803 - SRS / SRM / ECN / EQN / EQI / S20 / T20 / CDD

GKS□□-4A H□R

	o	p	h	h ₁	a	a ₅	a ₆	b ₅	b ₆	b ₇	c ₅	e ₅	f ₅	f ₆	m	n	s ₅
GKS05...	226	205	125	80	13	47.5	47.5	115	140	105	17	127	144	169	21	29	11
GKS06...	288	250	150	100	8	60	60	155	170	120	20	145	191	206	23	36	14
GKS07...	351	310	190	120	11	70	70	190	210	150	25	180	235	255	28	45	18
GKS09...	426	386	236	150	15	90	90	240	266	185	30	222	300	326	37	60	22
GKS11...	523	485	300	185	16	105	105	290	325	225	40	270	363	398	43	73	26
GKS14...	632	605	375	230	22	135	135	360	415	275	50	328	442	497	52	82	33

	d	l	d ₁	l ₁	u	t	a ₁	b ₁	e ₁	f ₁	i ₁	s ₁
	H7				JS9	+0,2		H7				6x60°
GKS05...	30	140	50	124	8	33.3	118	80	100	4	4	M8x15
	35				10	38.3						
GKS06...	40	160	65	140	12	43.3	140	100	120	5	5	M10x16
	45				14	48.8						
GKS07...	50	200	75	175	16	53.8	165	115	140	6	6	M12x18
	55				18	64.4						
GKS09...	60	240	95	210	20	74.9	205	145	175	7	7	M16x24
	70				22	85.4						
GKS11...	80	290	105	250	28	106.4	240	140	205	8	8	M20x32
	80				28	106.4						
GKS14...	100	350	135	305			290	170	250		7	M24x35

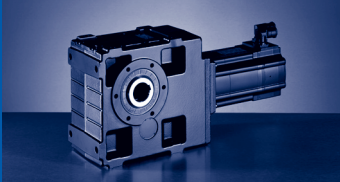

GKS [mm]

GKS□□-4A (MCA)

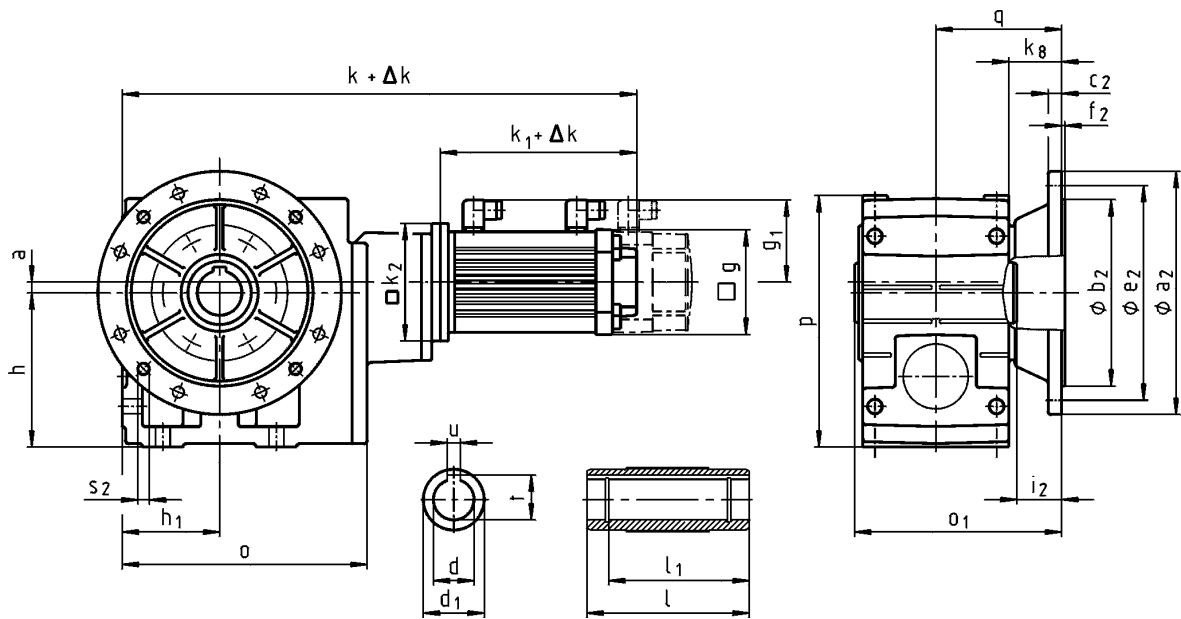

GKS□□-4A HAK ... RSO

		10I C40 ...S00	13I C41 ...S00	13I C34 ...F10	14L C20 ...S00	14L C41 ...S00	14L C16 ...F10	14L C35 ...F10	17N C23 ...S00	17N C41 ...S00
GKS05...	k	571	580	648						
GKS06...	k	644	653	721						
GKS07...	k	711	720	788		770		832		
GKS09...	k	800	809	877		859		921		898
GKS11...	k	910	919	987		969		1031		1008
GKS14...	k					1102		1164		1141
...RSO B0 ¹⁾	Δk	0								
...RSO P□ ¹⁾	Δk	25	35			33				35
	k_1	258	267	335		307		369		346
	k_2	145					180			
	g	102	131				142			165
	g_1	90	102				109			118

¹⁾ → 803 - SRS / SRM / ECN / EQN / EQI / S20 / T20 / CDD

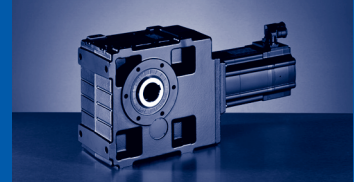

GKS□□-4A HAK ... RSO

		17N C17 ...F10	17N C35 ...F10	19S C23 ...S00	19S C42 ...S00	19S C17 ...F10	19S C35 ...F10	21X C25 ...S00	21X C42 ...S00	21X C17 ...F10	21X C35 ...F10
GKS09...	k	987									
GKS11...	k	1097		1076		1173		1155		1251	
GKS14...	k	1230		1209		1306		1288		1384	
...RSO B0 ¹⁾	Δ k	0									
...RSO P□ ¹⁾	Δ k	35		38				42			
	k ₁	435		408		505		479		575	
	k ₂	180		222				265			
	g	165		192				214			
	g ₁	118		161				172			

¹⁾ →  803 - SRS / SRM / ECN / EQN / EQI / S20 / T20 / CDD

GKS□□-4A HAK

	o	o ₁	p	h	h ₁	a	q	k _g
GKS05...	226	174	205	125	80	13	103.5	40
GKS06...	288	203 ²⁾ 202 ³⁾	250	150	100	8	122.5 ²⁾ 121.5 ³⁾	50 ²⁾ 49 ³⁾
GKS07...	351	256	310	190	120	11	155.5	66
GKS09...	426	301	386	236	150	15	180.5	70
GKS11...	523	351	485	300	185	16	205.5	71
GKS14...	632	411	605	375	230	22	235.5	72

²⁾ a₂ = 200

³⁾ a₂ = 250

	d	l	d ₁	l ₁	u	t	a ₂	b ₂	c ₂	e ₂	f ₂	i ₂	s ₂
	H7				JS9	+0,2		j7					
GKS05...	30	140	50	124	8	33.3	200	130	12	165	3.5	33.5	4 x 11
	35				10	38.3						42.5	
GKS06...	40	160	65	140	12	43.3	250	180	15	215	4	41.5	4 x 14
	45				14	48.8						55.5	
GKS07...	50	200	75	175	16	53.8	300	230	17	265	4	55.5	4 x 17.5
	55				18	64.4						60.5	
GKS09...	60	240	95	210	20	74.9	350	250	18	300	5	60.5	4 x 17.5
	70				22	85.4						8 x 17.5	
GKS11...	80	290	105	250	28	106.4	400	300	20	350	5	60.5	8 x 17.5
	80				22	85.4						8 x 17.5	
GKS14...	100	350	135	305	28	106.4	450	350	22	400	5	60.5	8 x 17.5

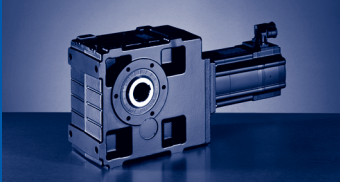

GKS [mm]

GKS□□-4A (MCA)

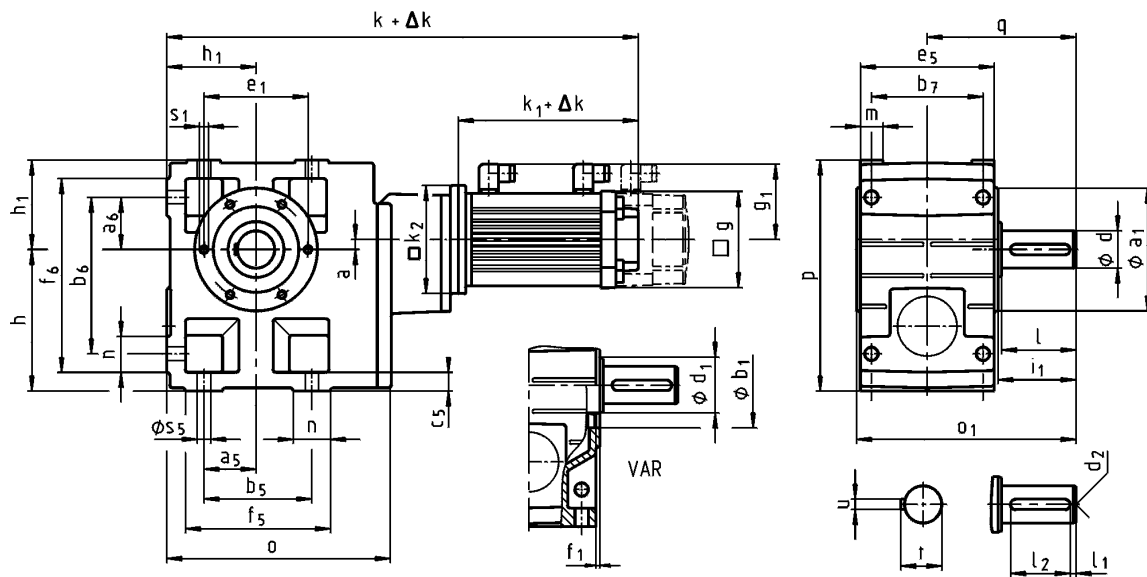

GKS□□-4A V□R ... RSO

		10I C40 ...S00	13I C41 ...S00	13I C34 ...F10	14L C20 ...S00	14L C41 ...S00	14L C16 ...F10	14L C35 ...F10	17N C23 ...S00	17N C41 ...S00
GKS05...	k	571	580	648						
GKS06...	k	644	653	721						
GKS07...	k	711	720	788	770		832			
GKS09...	k	800	809	877	859		921		898	
GKS11...	k	910	919	987	969		1031		1008	
GKS14...	k				1102		1164		1141	
...RSO B0 ¹⁾	Δk				0					
...RSO P□ ¹⁾	Δk	25	35			33			35	
	k_1	258	267	335	307		369		346	
	k_2		145				180			
	g	102	131			142			165	
	g_1	90	102			109			118	

¹⁾ → 803 - SRS / SRM / ECN / EQN / EQI / S20 / T20 / CDD

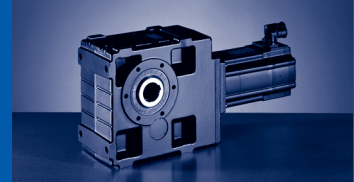

GKS□□-4A V□R ... RSO

		17N C17 ...F10	17N C35 ...F10	19S C23 ...S00	19S C42 ...S00	19S C17 ...F10	19S C35 ...F10	21X C25 ...S00	21X C42 ...S00	21X C17 ...F10	21X C35 ...F10		
GKS09...	k	987											
GKS11...	k	1097		1076		1173		1155		1251			
GKS14...	k	1230		1209		1306		1288		1384			
...RSO B0 ¹⁾	Δ k	0											
...RSO P□ ¹⁾	Δ k	35			38			42					
	k ₁	435		408		505		479		575			
	k ₂	180				222				265			
	g	165				192				214			
	g ₁	118				161				172			

¹⁾ → 803 - SRS / SRM / ECN / EQN / EQI / S20 / T20 / CDD

GKS□□-4A V□R

	o	o ₁	p	h	h ₁	a	q	a ₅	a ₆	b ₅	b ₆	b ₇	c ₅	e ₅	f ₅	f ₆	m	n	s ₅
GKS05...	226	197	205	125	80	13	130	47.5	47.5	115	140	105	17	127	144	169	21	29	11
GKS06...	288	236	250	150	100	8	160	60	60	155	170	120	20	145	191	206	23	36	14
GKS07...	351	296	310	190	120	11	200	70	70	190	210	150	25	180	235	255	28	45	18
GKS09...	426	356	386	236	150	15	240	90	90	240	266	185	30	222	300	326	37	60	22
GKS11...	523	445	485	300	185	16	305	105	105	290	325	225	40	270	363	398	43	73	26
GKS14...	632	544	605	375	230	22	375	135	135	360	415	275	50	328	442	497	52	82	33

	d	l	d ₁	l ₁	l ₂	d ₂	u	t	a ₁	b ₁	e ₁	f ₁	i ₁	s ₁
										H7				6x60°
GKS05...	30	60	50	6	45	M10	8	33	118	80	100	4	64	M8x15
GKS06...	40	80	65	7	63	M16	12	43	140	100	120		85	M10x16
GKS07...	50	100	75	8	80		14	53.5	165	115	140	5	105	M12x18
GKS09...	60	120	95		100	M20	18	64	205	145	175		125	M16x24
GKS11...	80	160	105	15	125		22	85	240	140	205	6	166	M20x32
GKS14...	100	200	135	18	160	M24	28	106	290	170	250		207	M24x35

d ≤ 50 mm: k6; d > 50 mm: m6

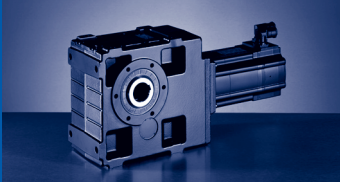

GKS [mm]

GKS□□-4A (MCA)

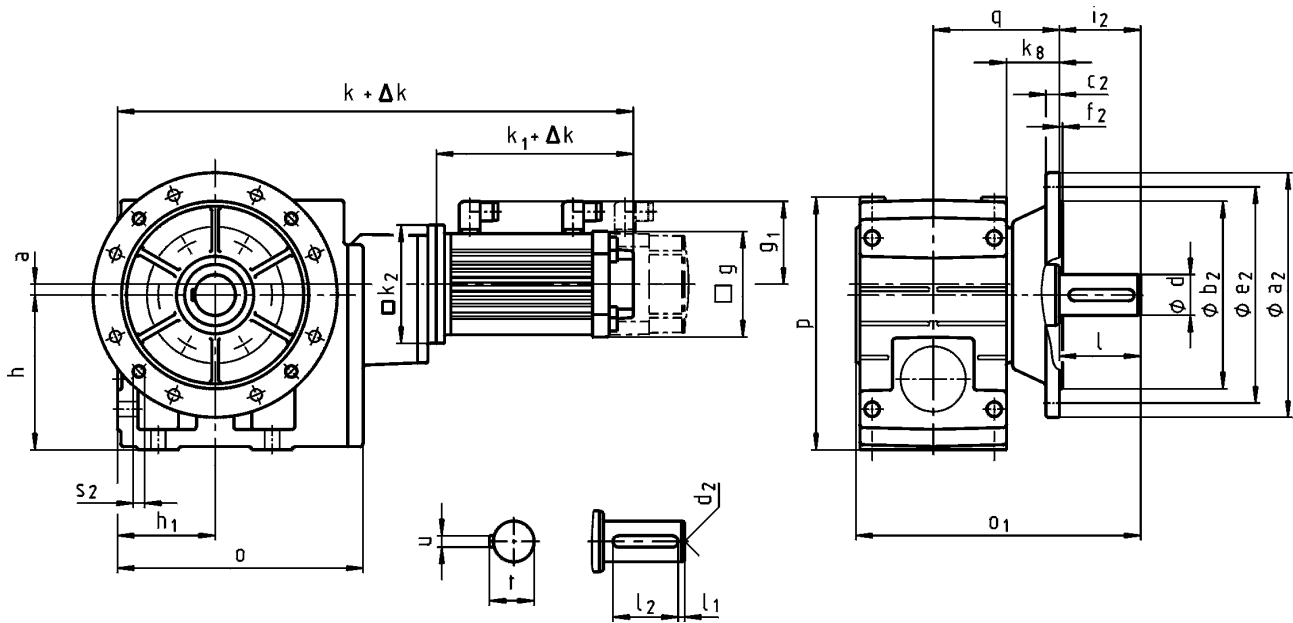

GKS□□-4A VAK ... RSO

		10I C40 ...S00	13I C41 ...S00	13I C34 ...F10	14L C20 ...S00	14L C41 ...S00	14L C16 ...F10	14L C35 ...F10	17N C23 ...S00	17N C41 ...S00
GKS05...	k	571	580	648						
GKS06...	k	644	653	721						
GKS07...	k	711	720	788	770		832			
GKS09...	k	800	809	877	859		921		898	
GKS11...	k	910	919	987	969		1031		1008	
GKS14...	k				1102		1164		1141	
...RSO B0 ¹⁾	Δk	0								
...RSO P□ ¹⁾	Δk	25	35		33				35	
	k_1	258	267	335	307		369		346	
	k_2	145			180					
	g	102	131		142			165		
	g_1	90	102		109			118		

¹⁾ → 803 - SRS / SRM / ECN / EQN / EQI / S20 / T20 / CDD

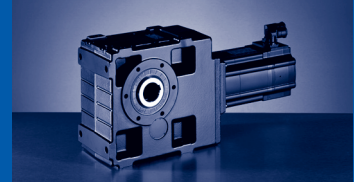

GKS□□-4A VAK ... RSO

		17N C17 ...F10	17N C35 ...F10	19S C23 ...S00	19S C42 ...S00	19S C17 ...F10	19S C35 ...F10	21X C25 ...S00	21X C42 ...S00	21X C17 ...F10	21X C35 ...F10
GKS09...	k	987									
GKS11...	k	1097		1076		1173		1155		1251	
GKS14...	k	1230		1209		1306		1288		1384	
...RSO B0 ¹⁾	Δ k	0									
...RSO P□ ¹⁾	Δ k	35		38				42			
	k ₁	435		408		505		479		575	
	k ₂	180				222				265	
	g	165				192				214	
	g ₁	118				161				172	

¹⁾ → 803 - SRS / SRM / ECN / EQN / EQI / S20 / T20 / CDD

GKS□□-4A VAK

	o	o ₁	p	h	h ₁	a	q	k _g
GKS05...	226	230	205	125	80	13	103.5	40
GKS06...	288	277	250	150	100	8	121.5	49
GKS07...	351	351	310	190	120	11	155.5	66
GKS09...	426	416	386	236	150	15	180.5	70
GKS11...	523	505	485	300	185	16	205.5	71
GKS14...	632	604	605	375	230	22	235.5	72

	d	l	l ₁	l ₂	d ₂	u	t	a ₂	b ₂	c ₂	e ₂	f ₂	i ₂	s ₂
									j7					
GKS05...	30	60	6	45	M10	8	33	200	130	12	165	3.5	60	4 x 11
GKS06...	40	80	7	63	M16	12	43	250	180	15	215	4	80	4 x 14
GKS07...	50	100	8	80		14	53.5						300	
GKS09...	60	120		100	M20	18	64	350	250	18	300		120	4 x 17.5
GKS11...	80	160	15	125		22	85	400	300	20	350	160		
GKS14...	100	200	18	160	M24	28	106	450	350	22	400	5	200	8 x 17.5

d ≤ 50 mm: k6; d > 50 mm: m6

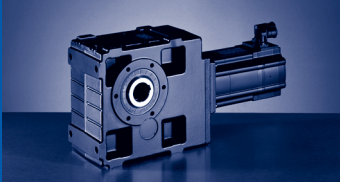

Hollow shaft with shrink disc

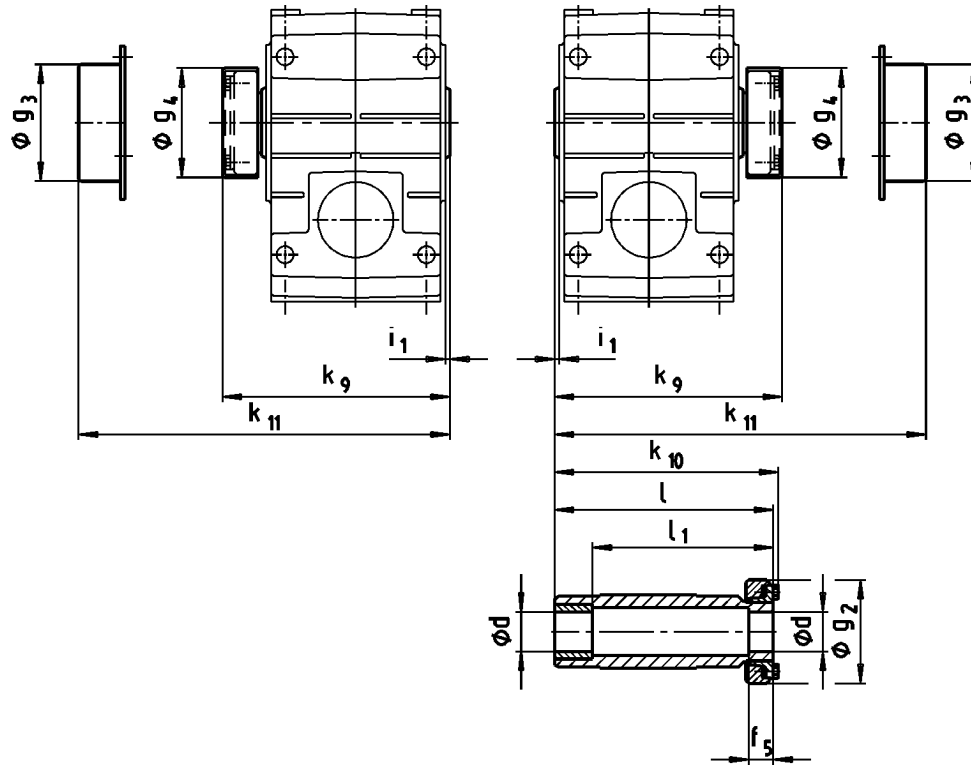

	Machine shaft	Hollow shaft with shrink disc						Protective cap		Cover	
	d	i ₁	k ₁₀	g ₂	l	l ₁	f ₅	k ₉	g ₄	k ₁₁	g ₃
	h6										
GKS04...	25 30	2.5	147.5	72	142	122	26	149.5	76	154	79
GKS05...	35	4	173.5	80	168	148	28	175.5	84	179	90
GKS06...	40	5	199.5	90	194	164	30	201.5	94	204	100
GKS07...	50		237.5	110	232	192	26	240.5	116	244	124
GKS09...	65		285	141	278	228	30	288	147	287	159
GKS11...	80	6	344	170	338	238	42	347	176	349	191
GKS14...	100	7	415	215	407	307	55	418	221	421	253

- ▶ Ensure that the strength of the shaft material is adequate in shrink disc designs. When using typical steels (e.g. C45, 42CrMo4), the torques listed in the selection tables can be used without restriction. When using material that is considerably weaker, please consult us. Medium surface roughness Rz must not exceed 15 µm (turning operation is sufficient).

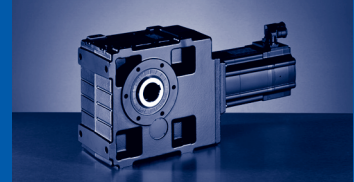

Hoseproof hollow shaft cover

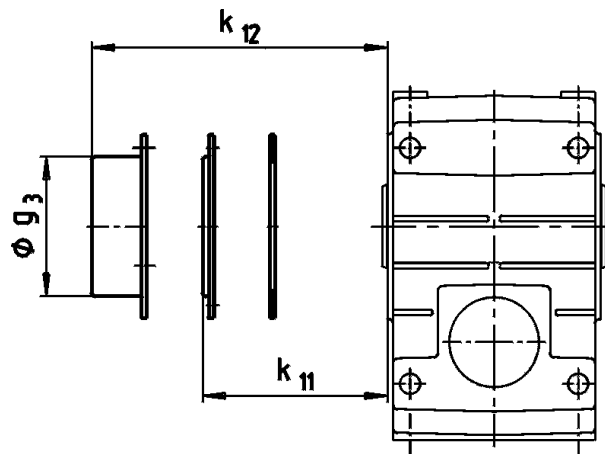

	Cover including seal		
	k_{11}	k_{12}	g_3
GKS04...	9		
GKS05...	10		
GKS06...	11		
GKS07...			
GKS09...		54	159
GKS11...		67	191
GKS14...		80	253

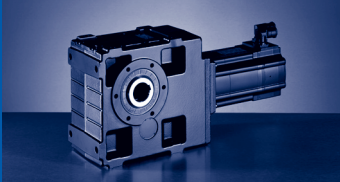

GKS & [mm]

Gearbox with 2nd output shaft end

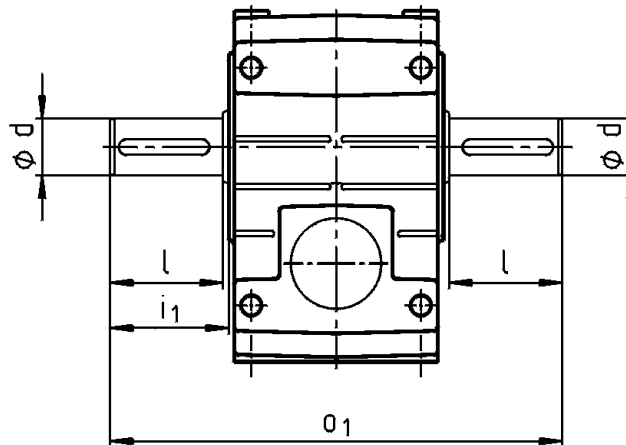

	d	l	i ₁	o ₁
GKS04...	25	50	52.5	215
GKS05...	30	60	64	260
GKS06...	40	80	85	320
GKS07...	50	100	105	400
GKS09...	60	120	125	480
GKS11...	80	160	166	610
GKS14...	100	200	207	750

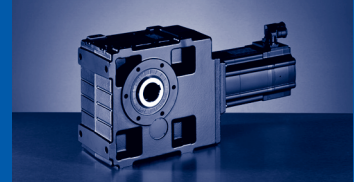

Torque plate at threaded pitch circle in position 3

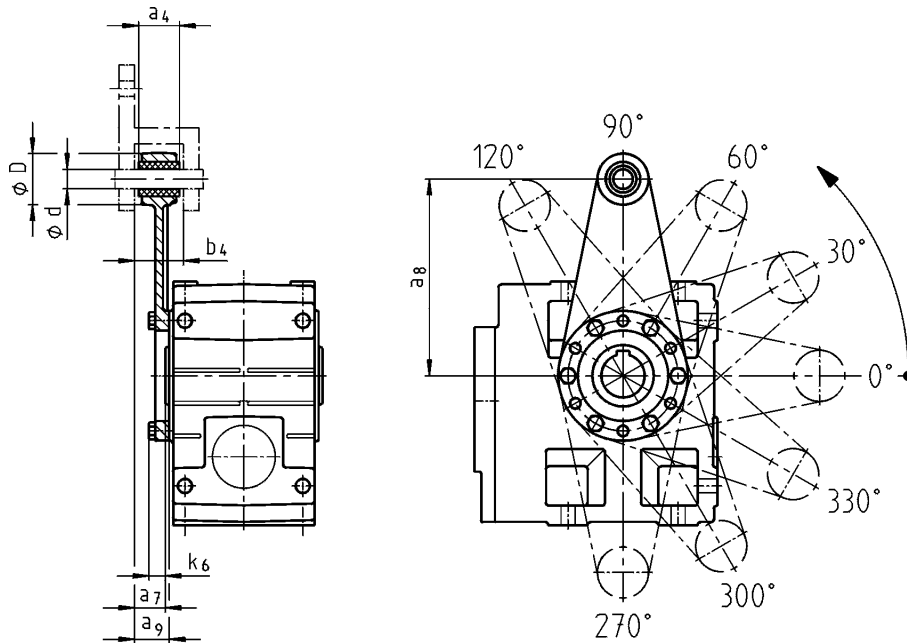

Torque plate at threaded pitch circle in position 5

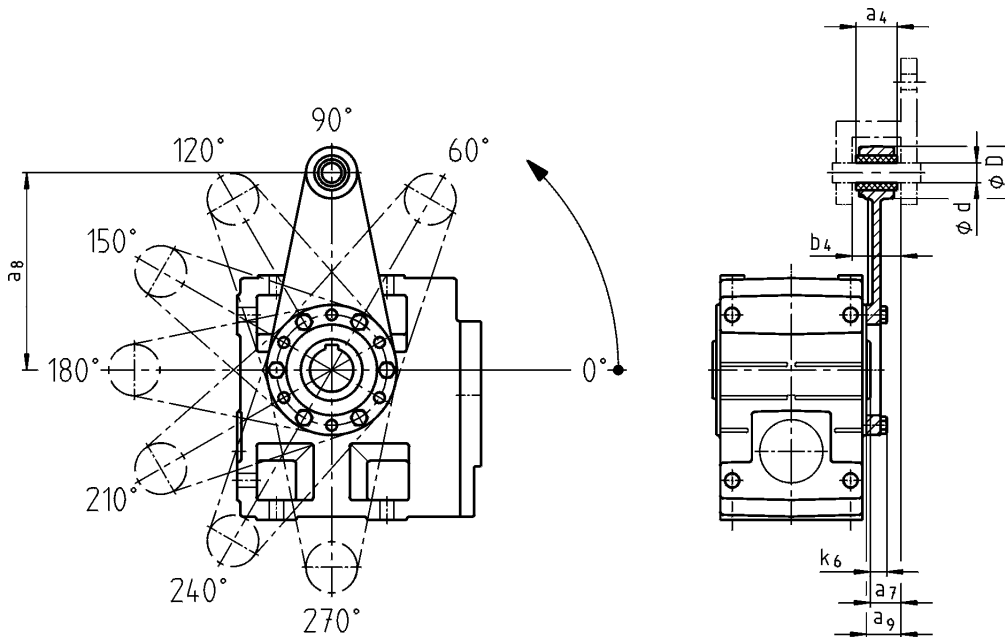

	Installation space							
	a ₇	b ₄	a ₄	a ₈	a ₉	d	D	k ₆
GKS04...	24	34.5	30	130	26.5	12	35	16
GKS05...	23.5	38.5	34	160	27.5	16	45	15
GKS06...	28	44.5	40	200	33	20	50	18
GKS07...	32.5	50.5	46	250	37.5	25	65	21

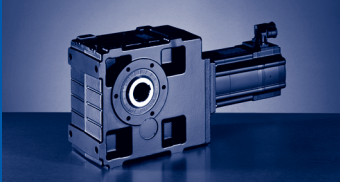

GKS & [mm]

Torque plate at casing foot in position 2, 4 or 6

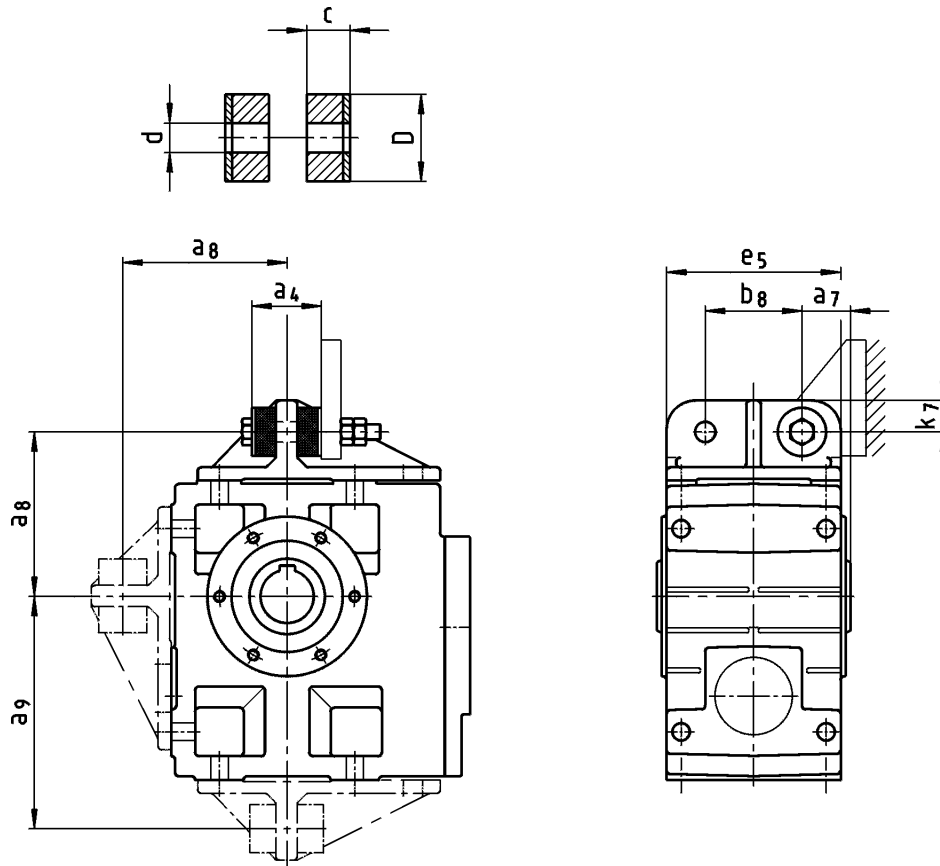

	a ₄	a ₇	a ₈	a ₉	b ₈	c	d	D	e ₅	k ₇
GKS04...	41	27.5	106	135	60	14.5	11	30	100	20
GKS05...	45	35	115	160	70	15	13	40	127	25
GKS06...	72	40	145	195	80	27	17	50	145	28
GKS07...	78	50	170	240	100	28	21	60	180	35
GKS09...	86	60	214	300	120	29	26	72	222	46
GKS11...	94	72.5	260	375	145	30	33	92	270	55
GKS14...	100	85	320	465	180		39	110	328	70

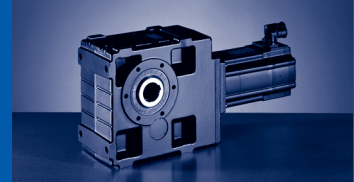

**Mounting set for hollow shaft circlip
Proposed design for auxiliary tools**

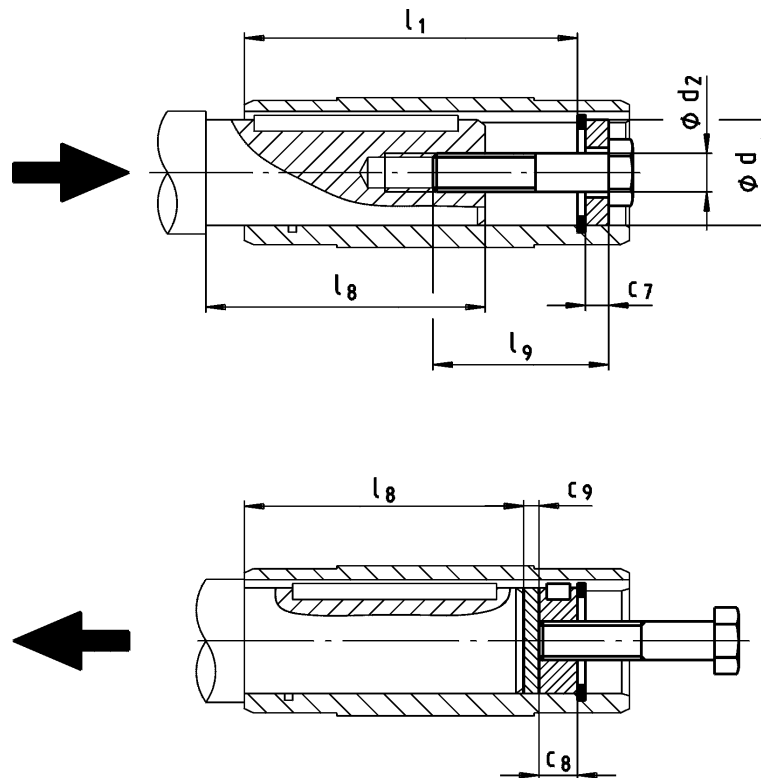

	Hollow shaft		Hollow shaft circlip mounting set (Assembly auxiliaries)			Auxiliary tools Disassembly		Machine shaft
	d	l ₁	d ₂	l ₉	c ₇	c ₈	c ₉	max l ₈
	H7							
GKS04...	25	100	M10	40	5	10	3	85
GKS05...	30				6			
	35	124	M12	50	7	12		107
GKS06...	40	140	M16	60	8	16	4	118
	45				9			
GKS07...	50	175			10			148
	55				11			
GKS09...	60	210	M20	80	13	20	5	182
	70	14						
GKS11...	80	250			16		6	221
GKS14...	100	305	M24	100	20	24	8	270

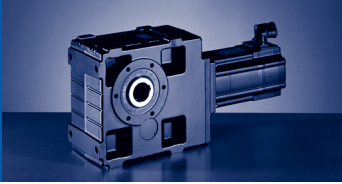

GKS & [mm]

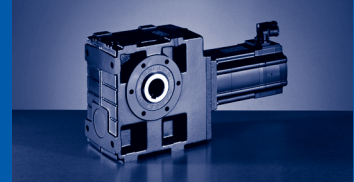

Permissible radial force

$$Fr_{zul} = \min(f_w \times f_{\alpha} \times Fr_{Tab}; f_w \times Fr_{max})$$

Permissible axial force

$$Fa_{zul} = Fa_{Tab} \text{ at } Fr = 0$$

At Fr and $Fa \neq 0$ please contact your Lenze sales office.

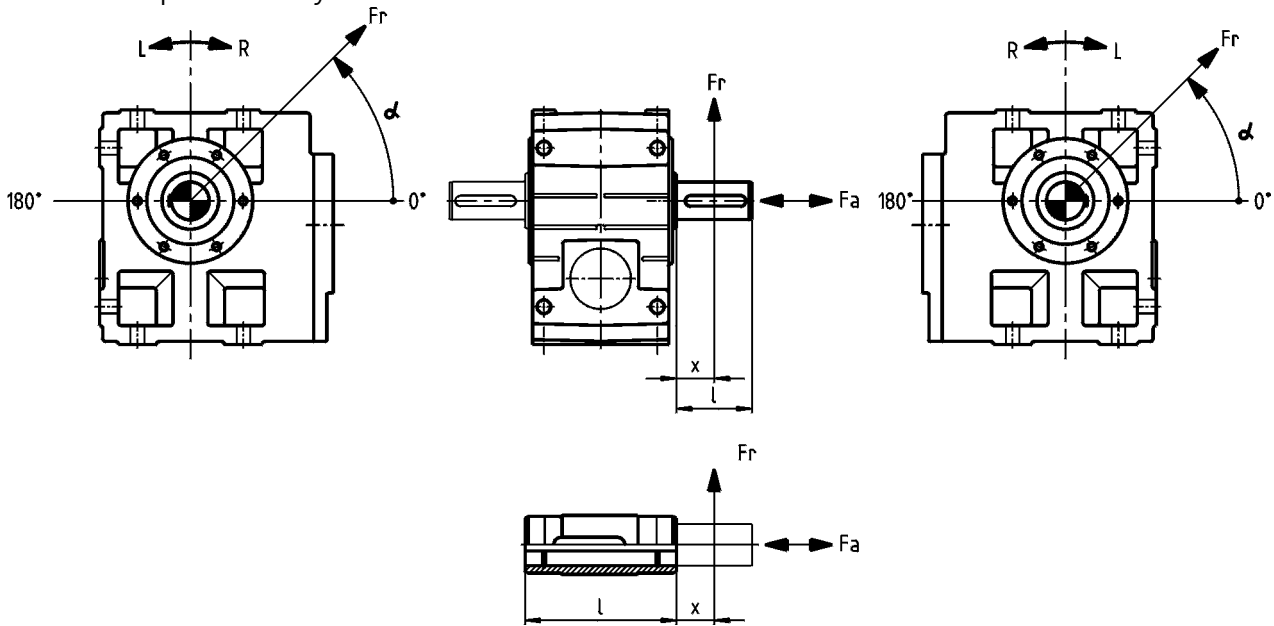

Effective direction factor f_{α} at output shaft

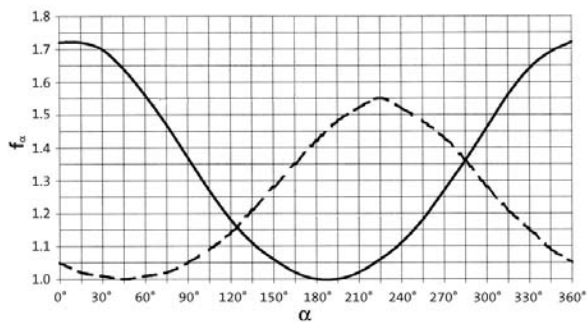

Additional load factor f_w at output shaft

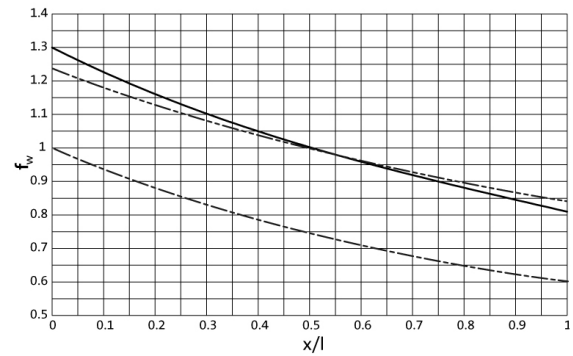

—— Direction of rotation R
 - - - Direction of rotation L

—— Solid shaft (V□R)
 - - - Solid shaft with flange (V□K)
 - · - Hollow shaft (H□□)

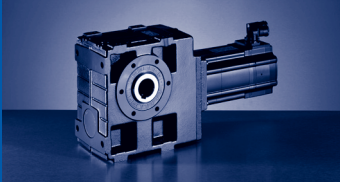

GSS [N]

Solid shaft without flange (V□R) Application of force Fr: centre of shaft journal (x = l/2) Fa _{Tab} only valid for Fr = 0								
	GSS04-2		GSS05-2/3		GSS06-2/3		GSS07-2/3	
n ₂ [min ⁻¹]	Fr _{Tab} [N]	Fa _{Tab} [N]	Fr _{Tab} [N]	Fa _{Tab} [N]	Fr _{Tab} [N]	Fa _{Tab} [N]	Fr _{Tab} [N]	Fa _{Tab} [N]
630	2200	2200	2300	1600	3400	1900	3700	1800
400	2400	2900	2500	2200	3500	2500	4000	2400
250	3000	3700	2900	2800	3600	3200	4200	3100
160	3500	4200	3400	3500	4200	4100	5100	4100
100	4100	4900	4000	4400	5000	5200	6300	5500
63	4200	5500	4300	5500	5900	6500	7700	7200
40	4200	5500	4300	6000	6900	8200	9300	9500
25	4200	5500	4300	6000	8200	9000	11300	12500
≤ 16	4200	5500	4300	6000	8500	9000	12000	12500
Fr _{max}	4200	-	4300	-	8500	-	12000	-

Solid shaft with flange (V□K) Application of force Fr: centre of shaft journal (x = l/2) Fa _{Tab} only valid for Fr = 0								
	GSS04-2		GSS05-2/3		GSS06-2/3		GSS07-2/3	
n ₂ [min ⁻¹]	Fr _{Tab} [N]	Fa _{Tab} [N]	Fr _{Tab} [N]	Fa _{Tab} [N]	Fr _{Tab} [N]	Fa _{Tab} [N]	Fr _{Tab} [N]	Fa _{Tab} [N]
630	2750	2100	3450	1500	5100	1600	5500	1400
400	3000	2800	3750	2000	5250	2200	6000	1900
250	4100	3500	4900	2500	7000	2800	7900	2400
160	4400	4000	4900	3100	8100	3500	9100	3200
100	4700	4200	4900	4000	9400	4500	10600	4300
63	4700	4200	4900	4900	9400	5700	12400	5900
40	4700	4200	4900	5500	9400	7300	14000	8000
25	4700	4200	4900	5500	9400	8800	14000	10000
≤ 16	4700	4200	4900	5500	9400	8800	14000	10000
Fr _{max}	4700	-	4900	-	9400	-	14000	-

Hollow shaft (H□□) Application of force Fr: on hollow shaft end face (x = 0) Fa _{Tab} only valid for Fr = 0								
	GSS04-2		GSS05-2/3		GSS06-2/3		GSS07-2/3	
n ₂ [min ⁻¹]	Fr _{Tab} [N]	Fa _{Tab} [N]	Fr _{Tab} [N]	Fa _{Tab} [N]	Fr _{Tab} [N]	Fa _{Tab} [N]	Fr _{Tab} [N]	Fa _{Tab} [N]
630	2800	2200	3000	1600	4400	1900	4600	1800
400	3000	2900	3200	2200	4600	2500	5100	2400
250	3800	3700	3600	2800	4800	3200	5600	3100
160	4500	4200	4300	3500	5600	4100	6700	4100
100	5300	4900	5100	4400	6600	5200	8200	5500
63	6000	5500	6000	5500	7700	6500	10000	7200
40	6000	5500	7000	6000	9100	8200	12100	9500
25	6000	5500	7500	6000	10700	9000	14800	12500
≤ 16	6000	5500	7500	6000	11500	9000	16000	12500
Fr _{max}	6000	-	7500	-	11500	-	16000	-

- ▶ Neither radial nor axial forces are permissible for the hollow shaft with shrink disc (S□□).

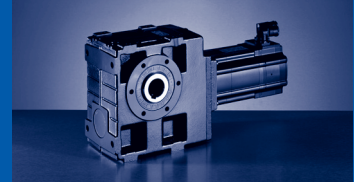

Position of ventilation, sealing elements and oil control

GSS05...07-2

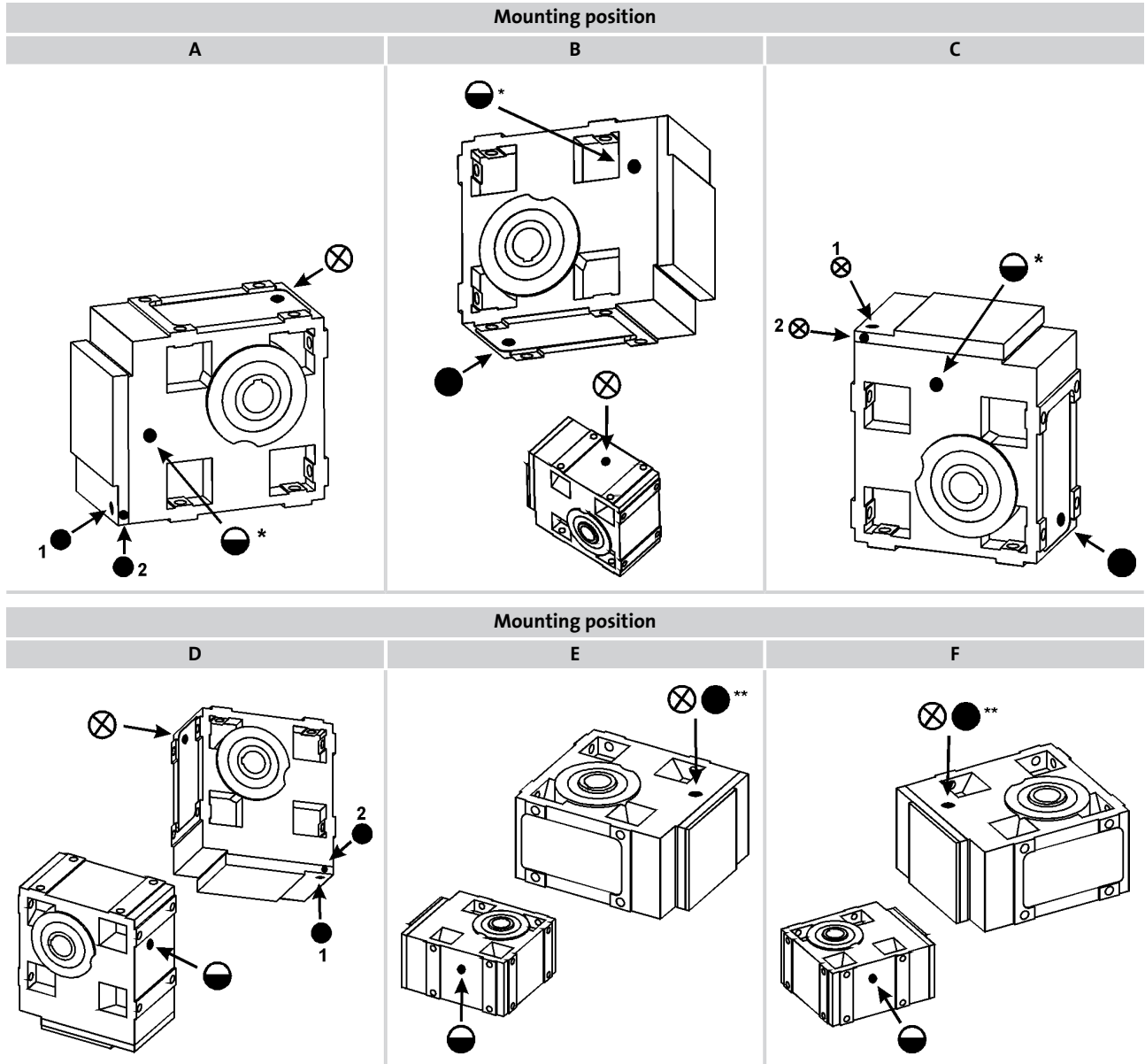

- ⊗ Ventilation/oil filler plug
- Oil drain plug
- ◐ Oil control plug
- * On both sides
- ** Opposite

Pos.1 standard
 Pos.2 only on GSS05-2A □□□ 14LC□□

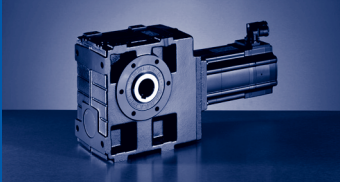

Position of ventilation, sealing elements and oil control

GSS05...07-3

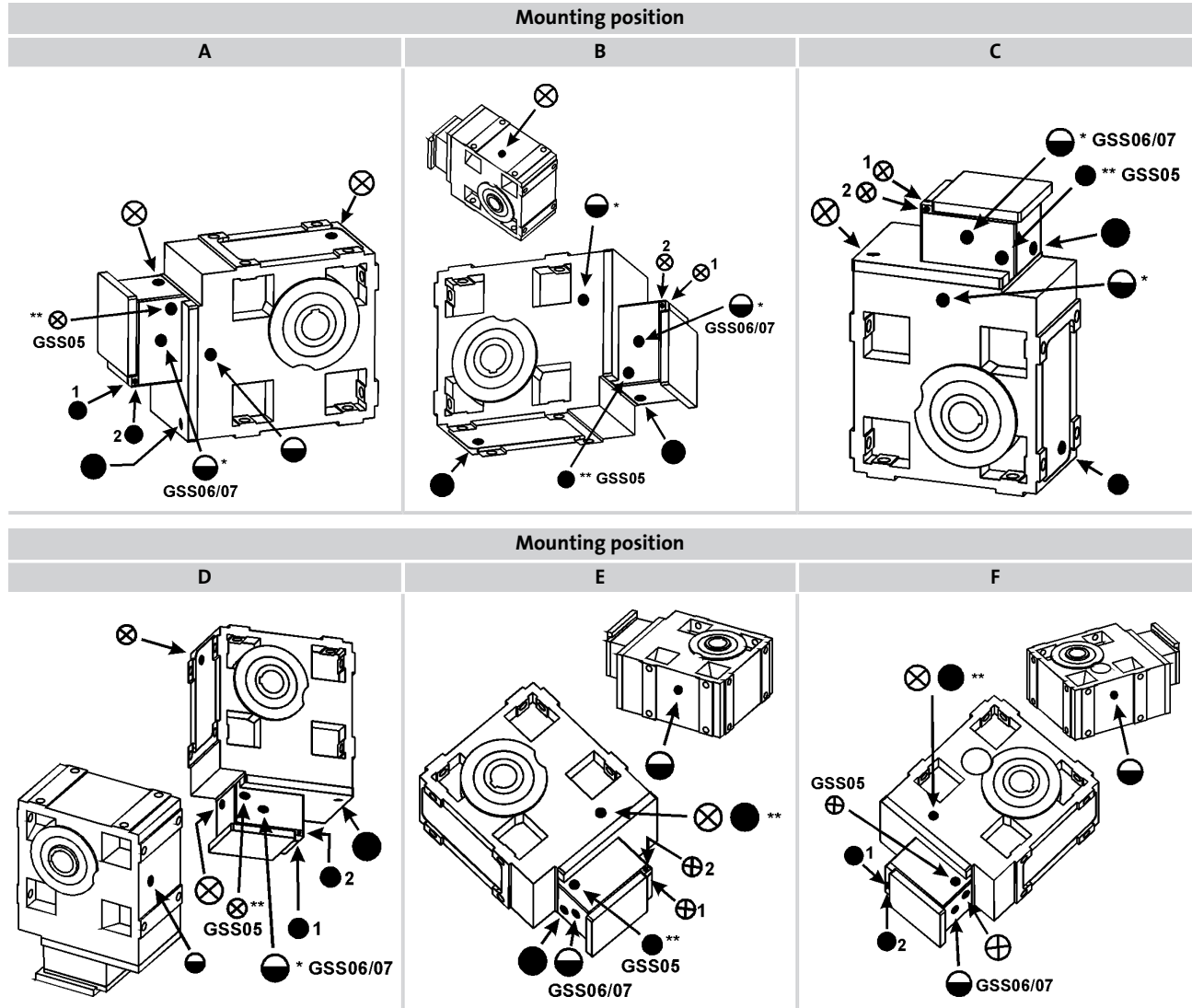

- ⊗ Ventilation/oil filler plug
- Oil drain plug
- ◐ Oil control plug
- * On both sides
- ** Opposite

Pos.1 standard
 Pos.2 only on GSS07-3A □□□ 14LC□□

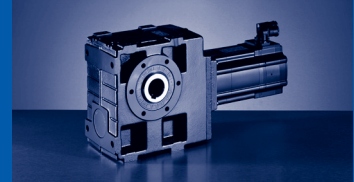

GSS□□-2S HAR/HBR...RSO B0

	06C C41	06F C41	06I C41	09D C41	09F C38	09H C41	09L C41	12D C20	12D C41	12H C15	12H C30	12H C35	12L C20	12L C41
GSS04...	14	15		17	18	19	21							
GSS05...	22	23		25	26	27	29	28			32			35
GSS06...	35	36		38	39	40	42	41			44			47
GSS07...				63	64	65	67	66			69			72

	14D C15	14D C36	14H C15	14H C32	14L C15	14L C32	14P C14	14P C32	19F C14	19F C30	19J C14	19J C30	19P C14	19P C30
GSS06...	46		51		55		60							
GSS07...	71		76		81		86		88		95			105

GSS□□-3S HAR/HBR...RSO B0

	06C C41	06F C41	06I C41	09D C41	09F C38	09H C41	09L C41	12D C20	12D C41	12H C15	12H C30	12H C35	12L C20	12L C41
GSS05...	25		26	28		29	31							
GSS06...	40		41	43		44	46							
GSS07...	67	68	69	70	71	72		74			77			80

Note additional weights.

Weights in [kg] with oil capacity for mounting position A, all given as approximate values

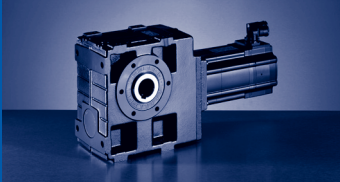

GSS [kg]

GSS□□-2A HAR/HBR...RSO B0

	10I C40 ...S00	13I C41 ...S00	13I C34 ...F10	14L C20 ...S00	14L C41 ...S00	14L C16 ...F10	14L C35 ...F10	17N C23 ...S00	17N C41 ...S00
GSS04...	18	23	24						
GSS05...	28	32	33		37		39		
GSS06...	40	44	45		50		52		58
GSS07...	65	69	70		75		77		82

	17N C17 ...F10	17N C35 ...F10	19S C23 ...S00	19S C42 ...S00	19S C17 ...F10	19S C35 ...F10	21X C25 ...S00	21X C42 ...S00	21X C17 ...F10	21X C35 ...F10
GSS06...	60									
GSS07...	85		106		109		123		126	

GSS□□-3A HAR/HBR...RSO B0

	10I C40 ...S00	13I C41 ...S00	13I C34 ...F10	14L C20 ...S00	14L C41 ...S00	14L C16 ...F10	14L C35 ...F10
GSS05...	28	33	35				
GSS06...	44	48	50				
GSS07...	73	77	78		82		84

Note additional weights.

Weights in [kg] with oil capacity for mounting position A, all given as approximate values

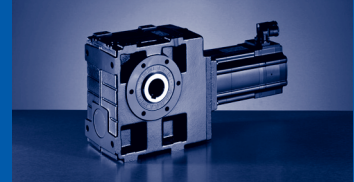

Additional weights MCS servo motors

	06C C41	06F C41	06I C41	09D C41	09F C38	09H C41	09L C41	12D C20	12D C41	12H C15	12H C30	12H C35	12L C20	12L C41
...P1	0.3			0.8			0.9							
...P2				0.5			1.2							
...SCS/SCM/SRM/SRS ...ECN/EQN	0.4			0.2			0.3							

	14D C15	14D C36	14H C15	14H C32	14L C15	14L C32	14P C14	14P C32	19F C14	19F C30	19J C14	19J C30	19P C14	19P C30
...P1	1.9						1.5							
...P2	3.1									4.3				
...SCS/SCM/SRM/SRS ...ECN/EQN	0.3													

Additional weights MCA servo motors

	10I C40 ...S00	13I C41 ...S00	13I C34 ...F10	14L C20 ...S00	14L C41 ...S00	14L C16 ...F10	14L C35 ...F10	17N C23 ...S00	17N C41 ...S00
...P1/P5								2.4	
...P2/P6	0.8	1.4		1.5					
...CDD ...ECN/EQN/EQI ...SCS/SCM/SRM/SRS/S20 ...T20	0.3	0.5		0.6			0.7		

	17N C17 ...F10	17N C35 ...F10	19S C23 ...S00	19S C42 ...S00	19S C17 ...F10	19S C35 ...F10	21X C25 ...S00	21X C42 ...S00	21X C17 ...F10	21X C35 ...F10
...P1/P5	2.4		4.8			5				
...P2/P6										
...CDD ...ECN/EQN/EQI ...SCS/SCM/SRM/SRS/S20 ...T20	0.7		1			1.1				

Additional weights gearbox

	Solid shaft	2nd output shaft end	Hollow shaft with shrink disc	Flange	Casing foot torque plate	Threaded hole circle torque plate
	V□□	V□□	S□□	□□K		
GSS04...	0.6	0.2	0.6	2.5	1.3	0.9
GSS05...	1	0.3	0.8	4	2.2	1.3
GSS06...	2.5	0.8	1	7	3.7	2.1
GSS07...	5	1.5	1.5	11	6.6	3.7

Weights in [kg]

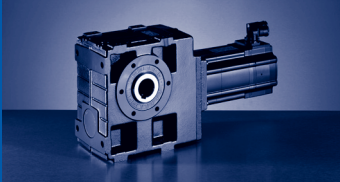

GSS [i]

► $i_g = z_g / z_t$

	i	z_g	z_t
GSS04-2	5.639	1015	180
	7.733	1160	150
	9.042	1085	120
	9.897	1247	126
	10.827	1624	150
	12.4	1240	100
	13.81	1740	126
	15.869	1333	84
	17.36	1736	100
	20.417	1225	60
	22.143	1860	84
	24.8	1240	50
	27.125	1953	72
	31.738	1333	42
	34.1	2046	60
	39.2	1960	50
	43.917	2108	48
	50	2100	42
	54.25	1953	36
	61.25	2205	
	68.2	2046	30
	77	2310	
	87.833	2108	24
	99.167	2380	
	111.318	2449	22
	125.682	2765	
139.5	2511	18	
157.5	2835		
183.786	2573	14	
207.5	2905		
GSS05-2	5.639	1015	180
	7.733	1160	150
	9.042	1085	120
	9.897	1247	126
	10.827	1624	150
	12.4	1240	100
	13.81	1740	126
	15.869	1333	84
	17.36	1736	100
	20.417	1225	60
	22.143	1860	84
	24.8	1240	50
	27.125	1953	72
	31.738	1333	42
	35.306	2542	72
	39.2	1960	50

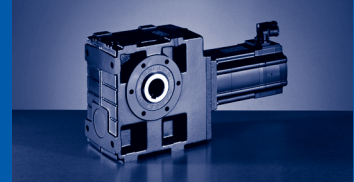

► $i_g = z_g / z_t$

	i	z_g	z_t
GSS05-2	43.917	2108	48
	50	2100	42
	54.25	1953	
	61.25	2205	36
	70.611	2542	
	79.722	2870	
	87.833	2108	
	99.167	2380	
	113.667	2728	24
	128.333	3080	
	137.95	2759	
	155.75	3115	20
	176.313	2821	
	199.063	3185	16
	GSS05-3	125.476	126480
153.708		132804	864
193.233		139128	720
222.133		133280	600
250.952		126480	
283.333		142800	504
307.417		132804	
347.083		149940	432
386.467		139128	
436.333		157080	360
497.722		143344	
561.944		161840	288
630.803		166532	
712.197		188020	264
790.5		170748	
892.5		192780	216
1041.452		174964	
1175.833		197540	168
GSS06-2	5.833	1050	180
	8	1200	150
	9.042	1085	120
	10.238	1290	126
	11.2	1680	150
	12.4	1240	100
	14.286	1800	126
	15.869	1333	84
	17.36	1736	100
	20.417	1225	60
	22.143	1860	84
	24.8	1240	50
	27.125	1953	72
	31.738	1333	42

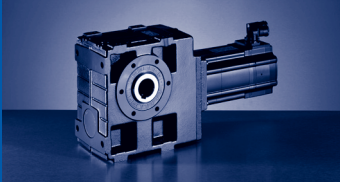

GSS [i]

► $i_g = z_g / z_t$

	i	z_g	z_t	
GSS06-2	35.306	2542	72	
	39.2	1960	50	
	43.917	2108	48	
	50	2100	42	
	54.25	1953	36	
	61.25	2205		
	70.611	2542		
	79.722	2870	24	
	87.833	2108		
	99.167	2380		
	113.667	2728	20	
	128.333	3080		
	137.95	2759		
	155.75	3115	16	
	174.375	2790		
	196.875	3150		
	GSS06-3	126.531	111600	882
		142.857	126000	
155		117180	756	
175		132300		
194.857		122760	630	
220		138600		
238.7		128898	540	
269.5		145530		
310.689		167772		
350.778		189420	360	
386.467		139128		
436.333		157080		
497.722		143344	288	
561.944		161840		
630.803		166532	264	
712.197		188020		
816.333		215512		
921.667		243320	216	
1023		220968		
1155		249480		
1241.55	223479	180		
1401.75	252315			
1635.693	228997	140		
1846.75	258545			
GSS07-2	5.862	1020	174	
	8.125	1170	144	
	9.086	1054	116	
	10	1260	126	
	11.2	1680	150	
	12.594	1209	96	
	14.286	1800	126	

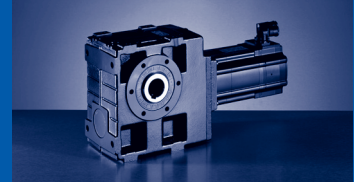

► $i_g = z_g / z_t$

	i	z_g	z_t
GSS07-2	15.5	1302	84
	17.36	1736	100
	20.517	1190	58
	22.143	1860	84
	25.188	1209	48
	27.125	1953	72
	31	1302	42
	35.306	2542	72
	39.2	1960	50
	43.271	2077	48
	50	2100	42
	54.25	1953	
	61.25	2205	36
	70.611	2542	
	79.722	2870	
	86.542	2077	
	97.708	2345	
	113.667	2728	24
	128.333	3080	
	137.95	2759	
155.75	3115	20	
174.375	2790		
196.875	3150	16	
GSS07-3	126.531	111600	
	142.857	126000	882
	155	117180	
	175	132300	
	201.746	152520	756
	227.778	172200	
	247.139	160146	
	279.028	180810	
	321.673	208444	648
	363.179	235340	
	394.245	170314	
	445.116	192290	432
	490.403	141236	
	553.681	159460	
	634.639	182776	
	716.528	206360	288
	833.556	240064	
	941.111	271040	
	1011.633	242792	240
	1142.167	274120	
1227.755	245551		
1386.175	277235	200	
1569.181	251069		
1771.656	283465	160	

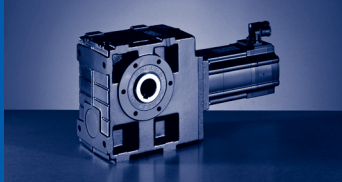

GSS [Nm]

GSS□□-□S (MCS)

$M_{2GN} \leq 180 \text{ Nm}$

GSS04-2S				06CC41	06FC41	06IC41	09DC41	09FC38	09HC41	09LC41	
				...S00	...S00	...S00	...S00	...S00	...S00	...S00	
i	M_{2GN}	J_G	M_1	0.6	1.2	1.5	2.3	3.1	3.8	4.5	
			n_1	4050	4050	4050	4050	3750	4050	4050	
			I_{M230}	2.6	2.9	3.2	4.6	5	6.8	8.4	
			I_{M400}	1.3	1.5	1.6	2.3	2.5	3.4	4.2	
			P_N	0.25	0.51	0.64	1	1.2	1.6	1.9	
			J_M	0.17	0.25	0.33	1.13	1.53	1.93	2.83	
5.639	86	1.12	M_2			7					
			c			5.8					
			$n_{2 \text{ Eck}}$			718					
			$n_{2 \text{ th}}$			718					
5.639	144	1.12	M_2				11	15	19	22	
			c				3.8	2.8	2.3	2	
			$n_{2 \text{ Eck}}$				718	665	718	718	
			$n_{2 \text{ th}}$				718	665	718	718	
7.733	158	0.65	M_2				15	21	26	31	
			c				4.7	3.5	2.8	2.4	
			$n_{2 \text{ Eck}}$				524	485	524	524	
			$n_{2 \text{ th}}$				524	485	524	524	
9.042	154	0.81	M_2				18	24	30	35	
			c				5.3	3.9	3.2	2.7	
			$n_{2 \text{ Eck}}$				448	415	448	448	
			$n_{2 \text{ th}}$				448	415	448	448	
9.897	161	0.43	M_2				20	27	33	39	
			c				5	3.7	3	2.5	
			$n_{2 \text{ Eck}}$				409	379	409	409	
			$n_{2 \text{ th}}$				409	379	409	409	
10.827	161	0.37	M_2				21	29	36	43	
			c				5	3.7	3	2.6	
			$n_{2 \text{ Eck}}$				374	346	374	374	
			$n_{2 \text{ th}}$				374	346	374	374	
12.4	170	0.49	M_2				24	33	41	49	
			c				4.8	3.5	2.9	2.4	
			$n_{2 \text{ Eck}}$				327	302	327	327	
			$n_{2 \text{ th}}$				327	302	327	327	
13.81	163	0.25	M_2				27	38	46	55	
			c				5	3.7	3	2.6	
			$n_{2 \text{ Eck}}$				293	272	293	293	
			$n_{2 \text{ th}}$				293	272	293	293	
15.869	180	0.33	M_2				31	43	53	63	
			c				4.1	3	2.5	2.1	
			$n_{2 \text{ Eck}}$				255	236	255	255	
			$n_{2 \text{ th}}$				255	236	255	255	
17.36	180	0.28	M_2			22	34	47	58	69	
			c				5.9	3.8	2.9	2	
			$n_{2 \text{ Eck}}$				233	233	233	233	
			$n_{2 \text{ th}}$				233	233	233	233	
20.417	153	0.67	M_2		19	24	37	50	62	73	
			c				5.4	4.3	2.8	2.1	1.7
			$n_{2 \text{ Eck}}$				198	198	198	198	
			$n_{2 \text{ th}}$				198	198	198	198	
22.143	180	0.2	M_2			28	44	60	74	87	
			c				5	3.3	2.4	2	1.7
			$n_{2 \text{ Eck}}$				183	183	169	183	
			$n_{2 \text{ th}}$				183	183	169	183	
24.8	171	0.42	M_2		23	30	46	63	77	91	
			c				4.9	3.9	2.6	1.9	1.3
			$n_{2 \text{ Eck}}$				163	163	163	163	
			$n_{2 \text{ th}}$				163	163	163	163	

$M \dots [\text{Nm}]$
 $n \dots [\text{min}^{-1}]$
 $J \dots [\text{kgcm}^2]$

$P \dots [\text{kW}]$
 $I \dots [\text{A}]$
 $i \dots [-]$
 $c \dots [-]$

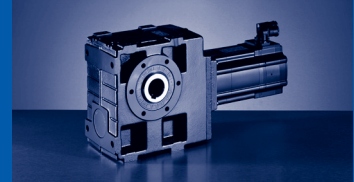

$M_{2GN} \leq 180 \text{ Nm}$

GSS04-2S				06CC41	06FC41	06IC41	09DC41	09FC38	09HC41	09LC41
				...500	...500	...500	...500	...500	...500	...500
i	M_{2GN}	J_G	M_1	0.6	1.2	1.5	2.3	3.1	3.8	4.5
			n_1	4050	4050	4050	4050	3750	4050	4050
			I_{M230}	2.6	2.9	3.2	4.6	5	6.8	8.4
			I_{M400}	1.3	1.5	1.6	2.3	2.5	3.4	4.2
			P_N	0.25	0.51	0.64	1	1.2	1.6	1.9
			J_M	0.17	0.25	0.33	1.13	1.53	1.93	2.83
27.125	180	0.14	M_2		27	35	54	73	90	107
			c		5.5	4.4	2.9	2.1	1.7	1.5
			$n_{2 \text{ Eck}}$		149	149	149	138	149	149
			$n_{2 \text{ th}}$		149	149	149	138	149	149
31.738	180	0.29	M_2		30	38	59	80	99	117
			c		4.2	3.3	2.2	1.6	1.3	1.1
			$n_{2 \text{ Eck}}$		128	128	128	118	128	128
			$n_{2 \text{ th}}$		128	128	128	118	128	128
34.1	180	0.1	M_2		34	44				
			c		4.7	3.8				
			$n_{2 \text{ Eck}}$		119	119				
			$n_{2 \text{ th}}$		119	119				
39.2	180	0.25	M_2		37	46	72	97	119	
			c		3.6	2.9	1.9	1.4	1.1	
			$n_{2 \text{ Eck}}$		103	103	103	96	103	
			$n_{2 \text{ th}}$		103	103	103	96	103	
43.917	180	0.06	M_2		45	56				
			c		3.9	3.1				
			$n_{2 \text{ Eck}}$		92	92				
			$n_{2 \text{ th}}$		92	92				
50	180	0.17	M_2		47	59	91	123		
			c		3.1	2.4	1.6	1.2		
			$n_{2 \text{ Eck}}$		81	81	81	75		
			$n_{2 \text{ th}}$		81	81	81	75		
54.25	180	0.13	M_2	25	52	65	101	136		
			c	5.9	3	2.4	1.6	1.2		
			$n_{2 \text{ Eck}}$	75	75	75	75	69		
			$n_{2 \text{ th}}$	75	75	75	75	69		
61.25	180	0.13	M_2	28	57	72	111	150		
			c	5.4	2.7	2.2	1.4	1		
			$n_{2 \text{ Eck}}$	66	66	66	66	61		
			$n_{2 \text{ th}}$	66	66	66	66	61		
68.2	180	0.09	M_2	31	65	81				
			c	5.1	2.6	2.1				
			$n_{2 \text{ Eck}}$	59	59	59				
			$n_{2 \text{ th}}$	59	59	59				
77	180	0.09	M_2	35	71	90				
			c	4.7	2.3	1.9				
			$n_{2 \text{ Eck}}$	53	53	53				
			$n_{2 \text{ th}}$	53	53	53				
87.833	180	0.06	M_2	40	83	104				
			c	4.3	2.1	1.7				
			$n_{2 \text{ Eck}}$	46	46	46				
			$n_{2 \text{ th}}$	46	46	46				
99.167	180	0.06	M_2	45	92	115				
			c	3.9	1.9	1.6				
			$n_{2 \text{ Eck}}$	41	41	41				
			$n_{2 \text{ th}}$	41	41	41				

$M \dots$ [Nm]
 $n \dots$ [min^{-1}]
 $J \dots$ [kgcm^2]

$P \dots$ [kW]
 $I \dots$ [A]
 $i \dots$ [-]
 $c \dots$ [-]

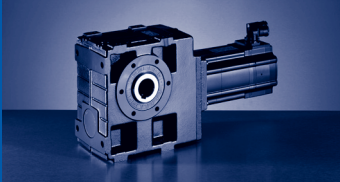

GSS [Nm]

GSS□□-□S (MCS)

$M_{2GN} \leq 360 \text{ Nm}$

GSS05-2S				06CC41	06FC41	06IC41	09DC41	09FC38	09HC41	09LC41	
				...S00	...S00	...S00	...S00	...S00	...S00	...S00	
i	M_{2GN}	J_G	M_1	0.6	1.2	1.5	2.3	3.1	3.8	4.5	
			n_1	4050	4050	4050	4050	3750	4050	4050	
			I_{M230}	2.6	2.9	3.2	4.6	5	6.8	8.4	
			I_{M400}	1.3	1.5	1.6	2.3	2.5	3.4	4.2	
			P_N	0.25	0.51	0.64	1	1.2	1.6	1.9	
			J_M	0.17	0.25	0.33	1.13	1.53	1.93	2.83	
5.639	175	2.82	M_2						18	22	
			c						5.7	4.8	
			$n_{2 \text{ Eck}}$							718	718
			$n_{2 \text{ th}}$							718	718
5.639	223	2.82	M_2								
			c								
			$n_{2 \text{ Eck}}$								
			$n_{2 \text{ th}}$								
7.733	212	1.66	M_2						25	30	
			c						5.2	4.4	
			$n_{2 \text{ Eck}}$						524	524	
			$n_{2 \text{ th}}$						524	524	
7.733	267	1.66	M_2								
			c								
			$n_{2 \text{ Eck}}$								
			$n_{2 \text{ th}}$								
9.042	251	2.01	M_2				17	23	29	34	
			c				5.8	4.3	3.5	3	
			$n_{2 \text{ Eck}}$				448	415	448	448	
			$n_{2 \text{ th}}$				448	415	448	448	
9.897	228	1.1	M_2					26	33	39	
			c					5.9	4.8	4.1	
			$n_{2 \text{ Eck}}$					379	409	409	
			$n_{2 \text{ th}}$					379	409	409	
9.897	271	1.1	M_2								
			c								
			$n_{2 \text{ Eck}}$								
			$n_{2 \text{ th}}$								
10.827	238	0.94	M_2					29	36	43	
			c					5.7	4.7	4	
			$n_{2 \text{ Eck}}$					346	374	374	
			$n_{2 \text{ th}}$					346	374	374	
10.827	272	0.94	M_2								
			c								
			$n_{2 \text{ Eck}}$								
			$n_{2 \text{ th}}$								
12.4	279	1.24	M_2					32	40	48	
			c					4.9	4	3.4	
			$n_{2 \text{ Eck}}$					302	327	327	
			$n_{2 \text{ th}}$					302	327	327	
13.81	256	0.64	M_2					37	46	55	
			c					5.3	4.4	3.7	
			$n_{2 \text{ Eck}}$					272	293	293	
			$n_{2 \text{ th}}$					272	293	293	
13.81	275	0.64	M_2								
			c								
			$n_{2 \text{ Eck}}$								
			$n_{2 \text{ th}}$								
15.869	301	0.84	M_2					42	51	61	
			c					4.9	4	3.4	
			$n_{2 \text{ Eck}}$					236	255	255	
			$n_{2 \text{ th}}$					236	255	255	

$M \dots$ [Nm]
 $n \dots$ [min^{-1}]
 $J \dots$ [kgcm^2]

$P \dots$ [kW]
 $I \dots$ [A]
 $i \dots$ [-]
 $c \dots$ [-]

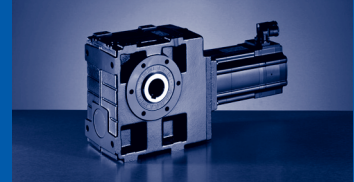

$M_{2GN} \leq 360 \text{ Nm}$

12DC20	12DC41	12HC15	12HC30	12HC35	12LC20	12LC41	GSS05-2S			
...500	...500	...500	...500	...500	...500	...500	M_1	J_G	M_{2GN}	i
5.5	4.3	10	8	7.5	13.5	11	n_1			
1950	4050	1500	3000	3525	1950	4050	I_{M230}			
5.2	8.8	7.6	10.5		11.8		I_{M400}			
2.6	4.5	3.8		5.7	5.9	10.2	P_N			
1.1	1.8	1.6	2.5	2.8	2.8	4.7	J_M			
4.12	4.12	7.42	7.42	7.42	10.72	10.72	M_2 c			
							$n_{2 \text{ Eck}}$ $n_{2 \text{ th}}$	2.82	175	5.639
	21	50	40	37	68	55	M_2 c			
	5.1	4.4	3.4	2.9	2.5	2	$n_{2 \text{ Eck}}$ $n_{2 \text{ th}}$	2.82	223	5.639
	718	266	532	625	346	718				
	718	266	532	625	346	718	M_2 c			
							$n_{2 \text{ Eck}}$ $n_{2 \text{ th}}$	1.66	212	7.733
37	29	69	55	51	94	76	M_2 c			
5.7	4.6	3.8	3	2.6	2.3	1.8	$n_{2 \text{ Eck}}$ $n_{2 \text{ th}}$	1.66	267	7.733
252	524	194	388	456	252	524				
252	524	194	388	456	252	524				
42	33	78	62	58	106	86	M_2 c			
5.1	3.1	3.1	2.6	1.8	2.1	1.2	$n_{2 \text{ Eck}}$ $n_{2 \text{ th}}$	2.01	251	9.042
216	448	166	332	390	216	448				
216	448	166	332	390	216	448				
							M_2 c			
							$n_{2 \text{ Eck}}$ $n_{2 \text{ th}}$	1.1	228	9.897
47	37	89	71	66	120	98	M_2 c			
5.2	4.2	3	2.8	2.4	2.1	1.7	$n_{2 \text{ Eck}}$ $n_{2 \text{ th}}$	1.1	271	9.897
197	409	152	303	356	197	409				
197	409	152	303	356	197	409				
							M_2 c			
							$n_{2 \text{ Eck}}$ $n_{2 \text{ th}}$	0.94	238	10.827
52	41	97	77	73	132	107	M_2 c			
4.9	4.1	2.8	2.8	2.4	2	1.6	$n_{2 \text{ Eck}}$ $n_{2 \text{ th}}$	0.94	272	10.827
180	374	139	277	326	180	374				
180	374	139	277	326	180	374				
58	45	108	86	81	147	119	M_2 c			
4.1	3.5	2.5	2.5	2	1.7	1.4	$n_{2 \text{ Eck}}$ $n_{2 \text{ th}}$	1.24	279	12.4
157	327	121	242	284	157	327				
157	327	121	242	284	157	327				
							M_2 c			
							$n_{2 \text{ Eck}}$ $n_{2 \text{ th}}$	0.64	256	13.81
67	52	125	99	93	170	138	M_2 c			
3.9	3.8	2.2	2.6	2.2	1.6	1.5	$n_{2 \text{ Eck}}$ $n_{2 \text{ th}}$	0.64	275	13.81
141	293	109	217	255	141	293				
141	293	109	217	255	141	293				
75	58	139	111	104	189	153	M_2 c			
3.5	3.5	2.1	2.1	2	1.4	1.4	$n_{2 \text{ Eck}}$ $n_{2 \text{ th}}$	0.84	301	15.869
123	255	95	189	222	123	255				
123	255	95	189	222	123	255				

M ... [Nm]
n ... [min⁻¹]
J ... [kgcm²]

P ... [kW]
I ... [A]
i [-]
c [-]

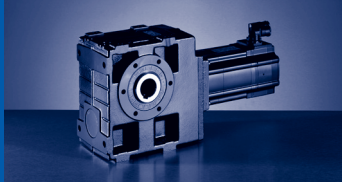

GSS [Nm]

GSS□□-□S (MCS)

$M_{2GN} \leq 360 \text{ Nm}$

GSS05-2S				06CC41	06FC41	06IC41	09DC41	09FC38	09HC41	09LC41
				...S00	...S00	...S00	...S00	...S00	...S00	...S00
i	M_{2GN}	J_G	M_1	0.6	1.2	1.5	2.3	3.1	3.8	4.5
			n_1	4050	4050	4050	4050	3750	4050	4050
			I_{M230}	2.6	2.9	3.2	4.6	5	6.8	8.4
			I_{M400}	1.3	1.5	1.6	2.3	2.5	3.4	4.2
			P_N	0.25	0.51	0.64	1	1.2	1.6	1.9
			J_M	0.17	0.25	0.33	1.13	1.53	1.93	2.83
17.36	311	0.72	M_2					46	56	67
			c				4.6	3.8	3.2	
			$n_{2 \text{ Eck}}$				216	233	233	
			$n_{2 \text{ th}}$				216	233	233	
20.417	253	1.6	M_2				35	48	59	70
			c				3.6	2.6	2.2	1.8
			$n_{2 \text{ Eck}}$				198	184	198	198
			$n_{2 \text{ th}}$				198	184	198	198
22.143	337	0.5	M_2				43	59	73	87
			c				5.3	3.9	3.2	2.7
			$n_{2 \text{ Eck}}$				183	169	183	183
			$n_{2 \text{ th}}$				183	169	183	183
24.8	280	1.06	M_2				44	61	75	89
			c				3.8	2.9	2.3	2
			$n_{2 \text{ Eck}}$				163	151	163	163
			$n_{2 \text{ th}}$				163	151	163	163
27.125	360	0.38	M_2				53	73	90	107
			c				4.6	3.4	2.8	2.4
			$n_{2 \text{ Eck}}$				149	138	149	149
			$n_{2 \text{ th}}$				149	138	149	149
31.738	306	0.73	M_2			37	58	79	97	115
			c			5.4	3.5	2.6	2.1	1.8
			$n_{2 \text{ Eck}}$			128	128	118	128	128
			$n_{2 \text{ th}}$			128	128	118	128	128
35.306	296	0.23	M_2			44				
			c			5.9				
			$n_{2 \text{ Eck}}$			115				
			$n_{2 \text{ th}}$			115				
35.306	360	0.23	M_2				70	95	117	139
			c				3.9	2.9	2.4	2
			$n_{2 \text{ Eck}}$				115	106	115	115
			$n_{2 \text{ th}}$				115	106	115	115
39.2	323	0.61	M_2		35	45	70	96	118	140
			c		5.9	4.7	3.1	2.3	1.9	1.6
			$n_{2 \text{ Eck}}$		103	103	103	96	103	103
			$n_{2 \text{ th}}$		103	103	103	96	103	103
43.917	306	0.17	M_2			56				
			c			5.1				
			$n_{2 \text{ Eck}}$			92				
			$n_{2 \text{ th}}$			92				
43.917	360	0.17	M_2				87	119	146	174
			c				3.4	2.5	2	1.7
			$n_{2 \text{ Eck}}$				92	85	92	92
			$n_{2 \text{ th}}$				92	85	92	92
50	353	0.44	M_2		46	58	91	123	152	181
			c		5	4	2.6	1.9	1.6	1.3
			$n_{2 \text{ Eck}}$		81	81	81	75	81	81
			$n_{2 \text{ th}}$		81	81	81	75	81	81
54.25	360	0.34	M_2		51	65	101	137	169	200
			c		4.8	3.8	2.5	1.9	1.5	1.3
			$n_{2 \text{ Eck}}$		75	75	75	69	75	75
			$n_{2 \text{ th}}$		75	75	75	69	75	75

$M \dots$ [Nm]
 $n \dots$ [min^{-1}]
 $J \dots$ [kgcm^2]

$P \dots$ [kW]
 $I \dots$ [A]
 $i \dots$ [-]
 $c \dots$ [-]

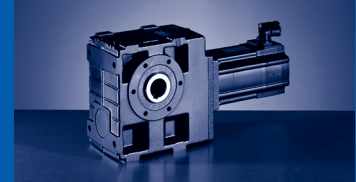

$M_{2GN} \leq 360 \text{ Nm}$

12DC20	12DC41	12HC15	12HC30	12HC35	12LC20	12LC41	GSS05-2S			
...500	...500	...500	...500	...500	...500	...500	M_1	J_G	M_{2GN}	i
5.5	4.3	10	8	7.5	13.5	11	n_1			
1950	4050	1500	3000	3525	1950	4050	I_{M230}			
5.2	8.8	7.6	10.5		11.8		I_{M400}			
2.6	4.5	3.8		5.7	5.9	10.2	P_N			
1.1	1.8	1.6	2.5	2.8	2.8	4.7	J_M			
4.12	4.12	7.42	7.42	7.42	10.72	10.72	M_2			
83	64	152	122	114	207	168	c	0.72	311	17.36
3.3	3.3	2	2	1.9	1.3		$n_{2\text{Eck}}$			
112	233	86	173	203	112	233	$n_{2\text{th}}$			
112	233	86	173	203	112	233	M_2			
88	67	163	128	118	220		c	1.6	253	20.417
2.5	1.9	1.5	1.4	1.1	1		$n_{2\text{Eck}}$			
96	198	74	147	173	96		$n_{2\text{th}}$			
96	198	73	147	173	96		M_2			
106	83	195	156	146	265	215	c	0.5	337	22.143
2.8	2.8	1.7	1.7	1.6	1.1	1.1	$n_{2\text{Eck}}$			
88	183	68	136	159	88	183	$n_{2\text{th}}$			
88	183	68	135	159	88	183	M_2			
110	85	203	161	150			c	1.06	280	24.8
2.2	2.1	1.4	1.3	1.2			$n_{2\text{Eck}}$			
79	163	61	121	142			$n_{2\text{th}}$			
79	163	60	121	142			M_2			
130	102	240	192	180			c	0.38	360	27.125
2.4	2.5	1.5	1.5	1.4			$n_{2\text{Eck}}$			
72	149	55	111	130			$n_{2\text{th}}$			
72	149	55	111	130			M_2			
142	110	261	208	194			c	0.73	306	31.738
1.9	1.9	1.2	1.1	1.1			$n_{2\text{Eck}}$			
61	128	47	95	111			$n_{2\text{th}}$			
61	128	47	95	111			M_2			
							c	0.23	296	35.306
							$n_{2\text{Eck}}$			
							$n_{2\text{th}}$			
							M_2			
							c	0.23	360	35.306
							$n_{2\text{Eck}}$			
							$n_{2\text{th}}$			
173	134	317					M_2			
1.6	1.6	1					c	0.61	323	39.2
50	103	38					$n_{2\text{Eck}}$			
50	103	38					$n_{2\text{th}}$			
							M_2			
							c	0.17	306	43.917
							$n_{2\text{Eck}}$			
							$n_{2\text{th}}$			
							M_2			
							c	0.17	360	43.917
							$n_{2\text{Eck}}$			
							$n_{2\text{th}}$			
221	172						M_2			
1.4	1.4						c	0.44	353	50
39	81						$n_{2\text{Eck}}$			
39	81						$n_{2\text{th}}$			
245	191						M_2			
1.3	1.3						c	0.34	360	54.25
36	75						$n_{2\text{Eck}}$			
36	75						$n_{2\text{th}}$			

M ... [Nm]
n ... [min⁻¹]
J ... [kgcm²]

P ... [kW]
I ... [A]
i [-]
c [-]

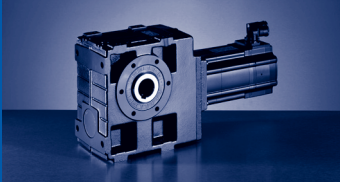

GSS [Nm]

GSS□□-□S (MCS)

$M_{2GN} \leq 360 \text{ Nm}$

GSS05-2S				06CC41	06FC41	06IC41	09DC41	09FC38	09HC41	09LC41
				...S00	...S00	...S00	...S00	...S00	...S00	...S00
i	M_{2GN}	J_G	M_1	0.6	1.2	1.5	2.3	3.1	3.8	4.5
			n_1	4050	4050	4050	4050	3750	4050	4050
			I_{M230}	2.6	2.9	3.2	4.6	5	6.8	8.4
			I_{M400}	1.3	1.5	1.6	2.3	2.5	3.4	4.2
			P_N	0.25	0.51	0.64	1	1.2	1.6	1.9
			J_M	0.17	0.25	0.33	1.13	1.53	1.93	2.83
61.25	360	0.33	M_2		57	72	112	152	187	222
			c		4.4	3.5	2.3	1.7	1.4	1.2
			n_2 Eck		66	66	66	61	66	66
			n_2 th		66	66	66	61	66	66
70.611	360	0.21	M_2		67	85	132	179	220	262
			c		4.1	3.2	2.1	1.6	1.3	1.1
			n_2 Eck		57	57	57	53	57	57
			n_2 th		57	57	57	53	57	57
79.722	360	0.21	M_2		75	94	147	199	245	
			c		3.7	3	1.9	1.4	1.2	
			n_2 Eck		51	51	51	47	51	
			n_2 th		51	51	51	47	51	
87.833	360	0.15	M_2		84	106	165	223	275	
			c		3.5	2.8	1.8	1.4	1.1	
			n_2 Eck		46	46	46	43	46	
			n_2 th		46	46	46	43	46	
99.167	360	0.15	M_2		94	118	183	248	305	
			c		3.2	2.6	1.7	1.3	1	
			n_2 Eck		41	41	41	38	41	
			n_2 th		41	41	41	38	41	
113.667	360	0.1	M_2	53	110	138				
			c	6	3	2.4				
			n_2 Eck	36	36	36				
			n_2 th	36	36	36				
128.333	360	0.09	M_2	59	122	154				
			c	5.5	2.8	2.2				
			n_2 Eck	32	32	32				
			n_2 th	32	32	32				
137.95	360	0.07	M_2	65	134	168				
			c	5.3	2.6	2.1				
			n_2 Eck	29	29	29				
			n_2 th	29	29	29				
155.75	360	0.07	M_2	72	149	187				
			c	4.8	2.4	1.9				
			n_2 Eck	26	26	26				
			n_2 th	26	26	26				

$M \dots$ [Nm]
 $n \dots$ [min^{-1}]
 $J \dots$ [kgcm^2]

$P \dots$ [kW]
 $I \dots$ [A]
 $i \dots$ [-]
 $c \dots$ [-]

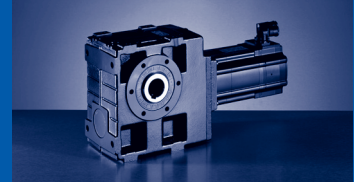

$M_{2GN} \leq 360 \text{ Nm}$

12DC20	12DC41	12HC15	12HC30	12HC35	12LC20	12LC41	GSS05-2S			
...500	...500	...500	...500	...500	...500	...500	M_1	J_G	M_{2GN}	i
5.5	4.3	10	8	7.5	13.5	11	n_1			
1950	4050	1500	3000	3525	1950	4050	I_{M230}			
5.2	8.8	7.6	10.5		11.8		I_{M400}			
2.6	4.5	3.8		5.7	5.9	10.2	P_N			
1.1	1.8	1.6	2.5	2.8	2.8	4.7	J_M			
4.12	4.12	7.42	7.42	7.42	10.72	10.72	M_2			
272	212						c	0.33	360	61.25
1.2	1.2						$n_{2 \text{ Eck}}$			
32	66						$n_{2 \text{ th}}$			
32	66						M_2			
							c	0.21	360	70.611
							$n_{2 \text{ Eck}}$			
							$n_{2 \text{ th}}$			
							M_2			
							c	0.21	360	79.722
							$n_{2 \text{ Eck}}$			
							$n_{2 \text{ th}}$			
							M_2			
							c	0.15	360	87.833
							$n_{2 \text{ Eck}}$			
							$n_{2 \text{ th}}$			
							M_2			
							c	0.15	360	99.167
							$n_{2 \text{ Eck}}$			
							$n_{2 \text{ th}}$			
							M_2			
							c	0.1	360	113.667
							$n_{2 \text{ Eck}}$			
							$n_{2 \text{ th}}$			
							M_2			
							c	0.09	360	128.333
							$n_{2 \text{ Eck}}$			
							$n_{2 \text{ th}}$			
							M_2			
							c	0.07	360	137.95
							$n_{2 \text{ Eck}}$			
							$n_{2 \text{ th}}$			
							M_2			
							c	0.07	360	155.75
							$n_{2 \text{ Eck}}$			
							$n_{2 \text{ th}}$			

M ... [Nm]
n ... [min⁻¹]
J ... [kgcm²]

P ... [kW]
I ... [A]
i [-]
c [-]

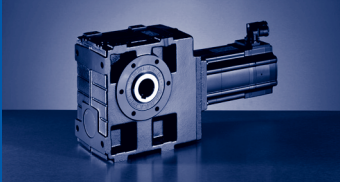

GSS [Nm]

GSS□□-□S (MCS)

$M_{2GN} \leq 360 \text{ Nm}$

GSS05-3S				06CC41	06FC41	06IC41	09DC41
				...500	...500	...500	...500
i	M_{2GN}	J_G	M_1				
			n_1	4050	4050	4050	4050
			I_{M230}	2.6	2.9	3.2	4.6
			I_{M400}	1.3	1.5	1.6	2.3
			P_N	0.25	0.51	0.64	1
			J_M	0.17	0.25	0.33	1.13
125.476	339	0.15	M_2	63	129	163	251
			c	4	2	1.6	1
			$n_{2 \text{ Eck}}$	32	32	32	32
			$n_{2 \text{ th}}$	32	32	32	32
153.708	356	0.12	M_2	77	158	198	
			c	3.5	1.7	1.4	
			$n_{2 \text{ Eck}}$	26	26	26	
			$n_{2 \text{ th}}$	26	26	26	
193.233	360	0.08	M_2	97	197	247	
			c	3	1.5	1.2	
			$n_{2 \text{ Eck}}$	21	21	21	
			$n_{2 \text{ th}}$	21	21	21	
222.133	360	0.21	M_2	103	210	263	
			c	3.4	1.7	1.4	
			$n_{2 \text{ Eck}}$	18	18	18	
			$n_{2 \text{ th}}$	18	18	18	
250.952	360	0.15	M_2	118	240	301	
			c	3	1.5	1.2	
			$n_{2 \text{ Eck}}$	16	16	16	
			$n_{2 \text{ th}}$	16	16	16	
283.333	360	0.15	M_2	130	265	332	
			c	2.7	1.3	1.1	
			$n_{2 \text{ Eck}}$	14	14	14	
			$n_{2 \text{ th}}$	14	14	14	
307.417	360	0.12	M_2	143	291		
			c	2.5	1.2		
			$n_{2 \text{ Eck}}$	13	13		
			$n_{2 \text{ th}}$	13	13		
347.083	360	0.11	M_2	158	321		
			c	2.2	1.1		
			$n_{2 \text{ Eck}}$	12	12		
			$n_{2 \text{ th}}$	12	12		
386.467	360	0.08	M_2	178			
			c	2			
			$n_{2 \text{ Eck}}$	11			
			$n_{2 \text{ th}}$	10			
436.333	360	0.08	M_2	197			
			c	1.8			
			$n_{2 \text{ Eck}}$	9			
			$n_{2 \text{ th}}$	9			
497.722	360	0.05	M_2	226			
			c	1.6			
			$n_{2 \text{ Eck}}$	8			
			$n_{2 \text{ th}}$	8			
561.944	360	0.05	M_2	249			
			c	1.4			
			$n_{2 \text{ Eck}}$	7			
			$n_{2 \text{ th}}$	7			

$M \dots$ [Nm]
 $n \dots$ [min^{-1}]
 $J \dots$ [kgcm^2]

$P \dots$ [kW]
 $I \dots$ [A]
 $i \dots$ [-]
 $c \dots$ [-]

GSS [Nm]
GSS□□-□S (MCS)

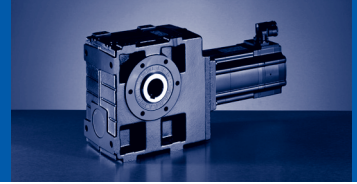

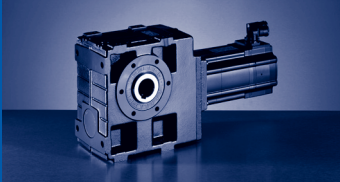

GSS [Nm]

GSS□□-□S (MCS)

$M_{2GN} \leq 720 \text{ Nm}$

GSS06-2S				06FC41	06IC41	09DC41	09FC38	09HC41	09LC41	12DC20	12DC41	12HC15	12HC30	
				...500	...500	...500	...500	...500	...500	...500	...500	...500	...500	
i	M_{2GN}	J_G	M_1	1.2	1.5	2.3	3.1	3.8	4.5	5.5	4.3	10	8	
			n_1	4050	4050	4050	3750	4050	4050	1950	4050	1500	3000	
			I_{M230}	2.9	3.2	4.6	5	6.8	8.4	5.2	8.8	7.6	10.5	
			I_{M400}	1.5	1.6	2.3	2.5	3.4	4.2	2.6	4.5	3.8		
			P_N	0.51	0.64	1	1.2	1.6	1.9	1.1	1.8	1.6	2.5	
			J_M	0.25	0.33	1.13	1.53	1.93	2.83	4.12	4.12	7.42	7.42	
5.833	308	6.97	M_2								22	51	41	
			c								5.4	5.8	4.5	
			$n_{2 \text{ Eck}}$									694	257	514
			$n_{2 \text{ th}}$									694	257	514
5.833	356	6.97	M_2											
			c											
			$n_{2 \text{ Eck}}$											
			$n_{2 \text{ th}}$											
8	353	4.22	M_2									71	56	
			c									4.8	4.6	
			$n_{2 \text{ Eck}}$									188	375	
			$n_{2 \text{ th}}$									188	375	
8	489	4.22	M_2											
			c											
			$n_{2 \text{ Eck}}$											
			$n_{2 \text{ th}}$											
9.042	417	5.54	M_2								33	77	63	
			c									5.9	5.1	3.9
			$n_{2 \text{ Eck}}$									448	166	332
			$n_{2 \text{ th}}$									448	166	332
10.238	380	2.81	M_2									91	72	
			c									4	4.4	
			$n_{2 \text{ Eck}}$									147	293	
			$n_{2 \text{ th}}$									147	293	
10.238	522	2.81	M_2											
			c											
			$n_{2 \text{ Eck}}$											
			$n_{2 \text{ th}}$											
11.2	308	2.39	M_2						44					
			c						6					
			$n_{2 \text{ Eck}}$						362					
			$n_{2 \text{ th}}$						362					
11.2	398	2.39	M_2									100	79	
			c									3.9	4.2	
			$n_{2 \text{ Eck}}$									134	268	
			$n_{2 \text{ th}}$									134	268	
11.2	524	2.39	M_2											
			c											
			$n_{2 \text{ Eck}}$											
			$n_{2 \text{ th}}$											
12.4	523	3.46	M_2								46	107	87	
			c									5.3	4.7	3.6
			$n_{2 \text{ Eck}}$									327	121	242
			$n_{2 \text{ th}}$									327	121	242
14.286	331	1.63	M_2						56					
			c						5.6					
			$n_{2 \text{ Eck}}$						284					
			$n_{2 \text{ th}}$						284					
14.286	428	1.63	M_2							69	53	129	102	
			c							5.9	5.9	3.3	4.1	
			$n_{2 \text{ Eck}}$							137	284	105	210	
			$n_{2 \text{ th}}$							137	284	105	210	

$M \dots [\text{Nm}]$
 $n \dots [\text{min}^{-1}]$
 $J \dots [\text{kgcm}^2]$

$P \dots [\text{kW}]$
 $I \dots [\text{A}]$
 $i [-]$
 $c [-]$

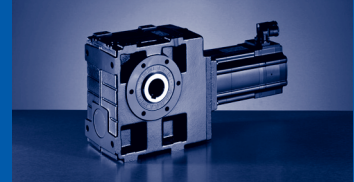

$M_{2GN} \leq 720 \text{ Nm}$

12HC35	12LC20	12LC41	14DC15	14DC36	14HC15	14HC32	14LC15	14LC32	14PC14	14PC32	GSS06-2S			
...S00	...S00	...S00	...S00	...S00	...S00	...S00	...S00	...S00	...S00	...S00	M_1	J_G	M_{2GN}	i
7.5	13.5	11	9.2	7.5	16	14	23	17.2	30	21	n_1			
3525	1950	4050	1500	3600	1500	3225	1500	3225	1350	3225	I_{M230}			
	11.8										I_{M400}			
5.7	5.9	10.2	4.5	7.5	6.6	11.9	9.7	15	10.8	15.6	P_N			
2.8	2.8	4.7	1.45	2.8	2.5	4.7	3.6	5.8	4.2	7.1	J_M			
7.42	10.72	10.72	8.22	8.22	14.32	14.32	23.44	23.44	34.74	34.82	M_2			
38	70	57									c	6.97	308	5.833
3.7	3.9	2.1									$n_{2 \text{ Eck}}$			
604	334	694									$n_{2 \text{ th}}$			
604	334	694												
				39	83	73	121	90	158	110	M_2			
				3.1	4.2	2	2.9	1.6	2.2	1.3	c	6.97	356	5.833
				617	257	553	257	553	231	553	$n_{2 \text{ Eck}}$			
				615	257	553	257	553	231	553	$n_{2 \text{ th}}$			
53	96	79									M_2			
4.1	3.6	2.4									c	4.22	353	8
441	244	506									$n_{2 \text{ Eck}}$			
441	244	506									$n_{2 \text{ th}}$			
				53	114	101	166	124	218	152	M_2			
				3.5	4.2	2.2	2.9	1.8	2.2	1.5	c	4.22	489	8
				450	188	403	188	403	169	403	$n_{2 \text{ Eck}}$			
				449	188	403	188	403	169	403	$n_{2 \text{ th}}$			
59	107	88	71	59	127	112	184	139	242	170	M_2			
3.7	3	2.3	5.6	3.4	3.2	2	2.2	1.6	1.7	1.3	c	5.54	417	9.042
390	216	448	166	398	166	357	166	357	149	357	$n_{2 \text{ Eck}}$			
390	216	448	166	397	166	357	166	357	149	357	$n_{2 \text{ th}}$			
68	124	101									M_2			
4	3	2.5									c	2.81	380	10.238
344	191	396									$n_{2 \text{ Eck}}$			
344	190	396									$n_{2 \text{ th}}$			
				68	147	129	214	160	280	195	M_2			
				3.6	3.5	2.2	2.4	1.8	1.9	1.4	c	2.81	522	10.238
				352	147	315	147	315	132	315	$n_{2 \text{ Eck}}$			
				351	147	315	147	315	132	315	$n_{2 \text{ th}}$			
											M_2			
											c	2.39	308	11.2
											$n_{2 \text{ Eck}}$			
											$n_{2 \text{ th}}$			
74	136	111									M_2			
4	2.9	2.4									c	2.39	398	11.2
315	174	362									$n_{2 \text{ Eck}}$			
315	174	362									$n_{2 \text{ th}}$			
			90	75	161	142	234	175	307	214	M_2			
			5.5	3.6	3.2	2.1	2.2	1.7	1.7	1.4	c	2.39	524	11.2
			134	321	134	288	134	288	121	288	$n_{2 \text{ Eck}}$			
			134	321	134	288	134	288	121	288	$n_{2 \text{ th}}$			
81	147	121	98	82	174	155	252	191	331	234	M_2			
3.3	2.7	2.1	5.1	3.1	2.9	1.8	2.1	1.5	1.6	1.2	c	3.46	523	12.4
284	157	327	121	290	121	260	121	260	109	260	$n_{2 \text{ Eck}}$			
284	157	327	121	290	121	260	121	260	109	260	$n_{2 \text{ th}}$			
											M_2			
											c	1.63	331	14.286
											$n_{2 \text{ Eck}}$			
											$n_{2 \text{ th}}$			
95	175	142									M_2			
3.7	2.4	2.3									c	1.63	428	14.286
247	137	284									$n_{2 \text{ Eck}}$			
247	137	284									$n_{2 \text{ th}}$			

$M \dots$ [Nm]
 $n \dots$ [min^{-1}]
 $J \dots$ [kgcm^2]

$P \dots$ [kW]
 $I \dots$ [A]
 $i [-]$
 $c [-]$

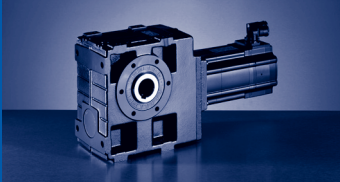

GSS [Nm]

GSS□□-□S (MCS)

$M_{2GN} \leq 720 \text{ Nm}$

GSS06-2S				06FC41	06IC41	09DC41	09FC38	09HC41	09LC41	12DC20	12DC41	12HC15	12HC30
				...500	...500	...500	...500	...500	...500	...500	...500	...500	...500
i	M_{2GN}	J_G	M_1	1.2	1.5	2.3	3.1	3.8	4.5	5.5	4.3	10	8
			n_1	4050	4050	4050	3750	4050	4050	1950	4050	1500	3000
			I_{M230}	2.9	3.2	4.6	5	6.8	8.4	5.2	8.8	7.6	10.5
			I_{M400}	1.5	1.6	2.3	2.5	3.4	4.2	2.6	4.5	3.8	
			P_N	0.51	0.64	1	1.2	1.6	1.9	1.1	1.8	1.6	2.5
			J_M	0.25	0.33	1.13	1.53	1.93	2.83	4.12	4.12	7.42	7.42
14.286	528	1.63	M_2 c $n_{2 \text{ Eck}}$ $n_{2 \text{ th}}$										
15.869	443	2.35	M_2 c $n_{2 \text{ Eck}}$ $n_{2 \text{ th}}$					51 5.6 255 255	62 4.8 255 255				
15.869	572	2.35	M_2 c $n_{2 \text{ Eck}}$ $n_{2 \text{ th}}$							59 5 255 255	137 4 95 95	111 3.3 189 189	
15.869	605	2.35	M_2 c $n_{2 \text{ Eck}}$ $n_{2 \text{ th}}$										
17.36	462	2.01	M_2 c $n_{2 \text{ Eck}}$ $n_{2 \text{ th}}$					56 5.5 233 233	67 4.6 233 233				
17.36	597	2.01	M_2 c $n_{2 \text{ Eck}}$ $n_{2 \text{ th}}$							64 4.9 233 233	150 3.9 86 86	122 3.3 173 173	
17.36	624	2.01	M_2 c $n_{2 \text{ Eck}}$ $n_{2 \text{ th}}$										
20.417	488	4.17	M_2 c $n_{2 \text{ Eck}}$ $n_{2 \text{ th}}$							90 4.1 96 96	71 3.3 198 198	166 2.9 147 147	134 2.2 147 147
22.143	494	1.39	M_2 c $n_{2 \text{ Eck}}$ $n_{2 \text{ th}}$					72 5.1 183 183	86 4.3 183 183				
22.143	638	1.39	M_2 c $n_{2 \text{ Eck}}$ $n_{2 \text{ th}}$							103 5.6 88 88	82 4.5 183 183	192 3.3 68 68	155 3 136 135
22.143	673	1.39	M_2 c $n_{2 \text{ Eck}}$ $n_{2 \text{ th}}$										
24.8	561	3.06	M_2 c $n_{2 \text{ Eck}}$ $n_{2 \text{ th}}$							110 4 79 79	88 3.1 163 163	202 2.7 61 60	165 2.1 121 121
27.125	518	1.04	M_2 c $n_{2 \text{ Eck}}$ $n_{2 \text{ th}}$				71 5.9 138 138	88 4.9 149 149	106 4.1 149 149				

$M \dots [\text{Nm}]$
 $n \dots [\text{min}^{-1}]$
 $J \dots [\text{kgcm}^2]$

$P \dots [\text{kW}]$
 $I \dots [\text{A}]$
 $i \dots [-]$
 $c \dots [-]$

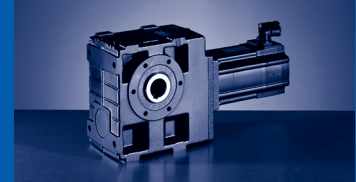

$M_{2GN} \leq 720 \text{ Nm}$

12HC35	12LC20	12LC41	14DC15	14DC36	14HC15	14HC32	14LC15	14LC32	14PC14	14PC32	GSS06-2S			
...S00	...S00	...S00	...S00	...S00	...S00	...S00	...S00	...S00	...S00	...S00	M_1	J_G	M_{2GN}	i
7.5	13.5	11	9.2	7.5	16	14	23	17.2	30	21	n_1			
3525	1950	4050	1500	3600	1500	3225	1500	3225	1350	3225	I_{M230}			
	11.8										I_{M400}			
5.7	5.9	10.2	4.5	7.5	6.6	11.9	9.7	15	10.8	15.6	P_N			
2.8	2.8	4.7	1.45	2.8	2.5	4.7	3.6	5.8	4.2	7.1	J_M			
7.42	10.72	10.72	8.22	8.22	14.32	14.32	23.44	23.44	34.74	34.82	M_2			
			117	96	208	182	301	224	394	274	c	1.63	528	14.286
			4.4	3.4	2.5	2	1.7	1.6	1.3	1.3	$n_{2 \text{ Eck}}$			
			105	252	105	226	105	226	95	226	$n_{2 \text{ th}}$			
			105	251	105	226	105	226	95	226	M_2			
											c	2.35	443	15.869
											$n_{2 \text{ Eck}}$			
											$n_{2 \text{ th}}$			
105	189	155									M_2			
3.1	2.6	2									c	2.35	572	15.869
222	123	255									$n_{2 \text{ Eck}}$			
222	123	255									$n_{2 \text{ th}}$			
			125	105	223	198	323	244	423	299	M_2			
			4.6	2.9	2.7	1.7	1.9	1.4	1.4	1.1	c	2.35	605	15.869
			95	227	95	203	95	203	85	203	$n_{2 \text{ Eck}}$			
			95	226	95	203	95	203	85	203	$n_{2 \text{ th}}$			
											M_2			
											c	2.01	462	17.36
											$n_{2 \text{ Eck}}$			
											$n_{2 \text{ th}}$			
114	206	170									M_2			
3	2.5	1.9									c	2.01	597	17.36
203	112	233									$n_{2 \text{ Eck}}$			
203	112	233									$n_{2 \text{ th}}$			
			137	115	244	217	353	267	463	327	M_2			
			4.4	2.8	2.5	1.6	1.8	1.3	1.3	1.1	c	2.01	624	17.36
			86	207	86	186	86	186	78	186	$n_{2 \text{ Eck}}$			
			86	207	86	186	86	186	78	186	$n_{2 \text{ th}}$			
125	227	185	152	125	268	236	388				M_2			
2.1	1.7	1.3	3.1	1.9	1.8	1.1	1.3				c	4.17	488	20.417
173	96	198	74	176	74	158	74				$n_{2 \text{ Eck}}$			
173	96	198	73	176	73	158	73				$n_{2 \text{ th}}$			
											M_2			
											c	1.39	494	22.143
											$n_{2 \text{ Eck}}$			
											$n_{2 \text{ th}}$			
146	263	217									M_2			
2.8	2.3	1.8									c	1.39	638	22.143
159	88	183									$n_{2 \text{ Eck}}$			
159	88	183									$n_{2 \text{ th}}$			
			175	146	310	277	450	341	589	417	M_2			
			3.7	2.6	2.1	1.5	1.5	1.2	1.1	1	c	1.39	673	22.143
			68	163	68	146	68	146	61	146	$n_{2 \text{ Eck}}$			
			68	162	68	146	68	146	61	146	$n_{2 \text{ th}}$			
155	279	229	186	155	328	292	474				M_2			
2	1.6	1.2	3	1.8	1.7	1.1	1.2				c	3.06	561	24.8
142	79	163	61	145	61	130	61				$n_{2 \text{ Eck}}$			
142	79	163	60	145	60	130	60				$n_{2 \text{ th}}$			
											M_2			
											c	1.04	518	27.125
											$n_{2 \text{ Eck}}$			
											$n_{2 \text{ th}}$			

$M \dots$ [Nm]
 $n \dots$ [min^{-1}]
 $J \dots$ [kgcm^2]

$P \dots$ [kW]
 $I \dots$ [A]
 i [-]
 c [-]

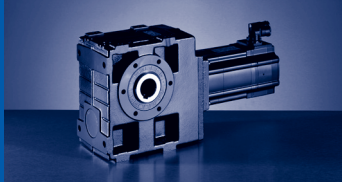

GSS [Nm]

GSS□□-□S (MCS)

$M_{2GN} \leq 720 \text{ Nm}$

GSS06-2S				06FC41	06IC41	09DC41	09FC38	09HC41	09LC41	12DC20	12DC41	12HC15	12HC30	
				...500	...500	...500	...500	...500	...500	...500	...500	...500	...500	
i	M_{2GN}	J_G	M_1	1.2	1.5	2.3	3.1	3.8	4.5	5.5	4.3	10	8	
			n_1	4050	4050	4050	3750	4050	4050	1950	4050	1500	3000	
			I_{M230}	2.9	3.2	4.6	5	6.8	8.4	5.2	8.8	7.6	10.5	
			I_{M400}	1.5	1.6	2.3	2.5	3.4	4.2	2.6	4.5	3.8		
			P_N	0.51	0.64	1	1.2	1.6	1.9	1.1	1.8	1.6	2.5	
			J_M	0.25	0.33	1.13	1.53	1.93	2.83	4.12	4.12	7.42	7.42	
27.125	669	1.04	M_2							127	101	235	190	
			c								4.8	4.3	2.8	2.9
			$n_{2 \text{ Eck}}$								72	149	55	111
			$n_{2 \text{ th}}$								72	149	55	111
27.125	718	1.04	M_2											
			c											
			$n_{2 \text{ Eck}}$											
			$n_{2 \text{ th}}$											
31.738	609	2.1	M_2			58	80	99	118	141	112	259	211	
			c			5.5	4.1	3.3	2.8	3.7	2.9	2.3	2	
			$n_{2 \text{ Eck}}$			128	118	128	128	61	128	47	95	
			$n_{2 \text{ th}}$			128	118	128	128	61	128	47	95	
35.306	537	0.66	M_2				93	115	138					
			c				5.5	4.5	3.8					
			$n_{2 \text{ Eck}}$				106	115	115					
			$n_{2 \text{ th}}$				106	115	115					
35.306	693	0.66	M_2							166	131	306	248	
			c								4.1	4	2.2	2.5
			$n_{2 \text{ Eck}}$								55	115	43	85
			$n_{2 \text{ th}}$								55	115	42	85
39.2	637	1.64	M_2			71	98	121	144	173	137	317	258	
			c			5.1	3.8	3.1	2.6	3.2	2.7	2	1.8	
			$n_{2 \text{ Eck}}$			103	96	103	103	50	103	38	77	
			$n_{2 \text{ th}}$			103	96	103	103	50	103	38	77	
43.917	554	0.48	M_2				116	144	172					
			c				4.7	3.8	3.2					
			$n_{2 \text{ Eck}}$				85	92	92					
			$n_{2 \text{ th}}$				85	92	92					
43.917	715	0.48	M_2							207	163	380	308	
			c								3.4	3.6	1.9	2.1
			$n_{2 \text{ Eck}}$								44	92	34	68
			$n_{2 \text{ th}}$								44	92	34	68
50	693	1.16	M_2			91	125	154	183	221	175	403	328	
			c			4.8	3.5	2.9	2.4	2.7	2.5	1.7	1.7	
			$n_{2 \text{ Eck}}$			81	75	81	81	39	81	30	60	
			$n_{2 \text{ th}}$			81	75	81	81	39	81	30	60	
54.25	720	0.96	M_2			100	136	168	200	241	191	440	359	
			c			4.7	3.5	2.9	2.4	2.7	2.5	1.6	1.6	
			$n_{2 \text{ Eck}}$			75	69	75	75	36	75	28	55	
			$n_{2 \text{ th}}$			75	69	75	75	36	75	28	55	
61.25	720	0.89	M_2			112	153	188	224	270	214	492	402	
			c			4.5	3.3	2.7	2.3	2.4	2.4	1.5	1.5	
			$n_{2 \text{ Eck}}$			66	61	66	66	32	66	25	49	
			$n_{2 \text{ th}}$			66	61	66	66	32	66	24	49	
70.611	720	0.61	M_2			130	177	218	260	314	248	569	465	
			c			4.2	3.1	2.5	2.1	2.2	2.2	1.3	1.4	
			$n_{2 \text{ Eck}}$			57	53	57	57	28	57	21	43	
			$n_{2 \text{ th}}$			57	53	57	57	28	57	21	42	
79.722	720	0.57	M_2		93	146	199	245	291	351	278	635	520	
			c		5.8	3.8	2.8	2.3	1.9	2	2	1.1	1.2	
			$n_{2 \text{ Eck}}$		51	51	47	51	51	25	51	19	38	
			$n_{2 \text{ th}}$		51	51	47	51	51	24	51	19	38	

M ... [Nm]
 n ... [min⁻¹]
 J ... [kgcm²]

P ... [kW]
 I ... [A]
 i [-]
 c [-]

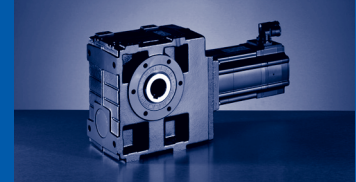

$M_{2GN} \leq 720 \text{ Nm}$

12HC35	12LC20	12LC41	14DC15	14DC36	14HC15	14HC32	14LC15	14LC32	14PC14	14PC32	GSS06-2S			
...S00	...S00	...S00	...S00	...S00	...S00	...S00	...S00	...S00	...S00	...S00	M_1	J_G	M_{2GN}	i
7.5	13.5	11	9.2	7.5	16	14	23	17.2	30	21	n_1			
3525	1950	4050	1500	3600	1500	3225	1500	3225	1350	3225	I_{M230}			
	11.8										I_{M400}			
5.7	5.9	10.2	4.5	7.5	6.6	11.9	9.7	15	10.8	15.6	P_N			
2.8	2.8	4.7	1.45	2.8	2.5	4.7	3.6	5.8	4.2	7.1	J_M			
7.42	10.72	10.72	8.22	8.22	14.32	14.32	23.44	23.44	34.74	34.82	M_2			
179	322	265									c	1.04	669	27.125
2.7	2	1.7									$n_{2 \text{ Eck}}$			
130	72	149									$n_{2 \text{ th}}$			
130	72	149									M_2			
			215	179	380	339	550	417			c	1.04	718	27.125
			3.3	2.5	1.9	1.4	1.3	1.2			$n_{2 \text{ Eck}}$			
			55	133	55	119	55	119			$n_{2 \text{ th}}$			
			55	132	55	119	55	119			M_2			
198	355	293	237	199	418		604				c	2.1	609	31.738
1.8	1.5	1.1	2.5	1.7	1.5		1				$n_{2 \text{ Eck}}$			
111	61	128	47	113	47		47				$n_{2 \text{ th}}$			
111	61	128	47	113	47		47				M_2			
											c	0.66	537	35.306
											$n_{2 \text{ Eck}}$			
											$n_{2 \text{ th}}$			
233	419	345									M_2			
2.5	1.7	1.6									c	0.66	693	35.306
100	55	115									$n_{2 \text{ Eck}}$			
100	55	115									$n_{2 \text{ th}}$			
242	435	358	291	243	512						M_2			
1.7	1.3	1.1	2.2	1.6	1.2						c	1.64	637	39.2
90	50	103	38	92	38						$n_{2 \text{ Eck}}$			
90	50	103	38	92	38						$n_{2 \text{ th}}$			
											M_2			
											c	0.48	554	43.917
											$n_{2 \text{ Eck}}$			
											$n_{2 \text{ th}}$			
290	521	428									M_2			
2.1	1.4	1.4									c	0.48	715	43.917
80	44	92									$n_{2 \text{ Eck}}$			
80	44	92									$n_{2 \text{ th}}$			
309	553		370	309	650						M_2			
1.6	1.1		1.9	1.5	1.1						c	1.16	693	50
71	39		30	72	30						$n_{2 \text{ Eck}}$			
71	39		30	72	30						$n_{2 \text{ th}}$			
337	604		404	338	710						M_2			
1.6	1.1		1.8	1.5	1						c	0.96	720	54.25
65	36		28	66	28						$n_{2 \text{ Eck}}$			
65	36		28	66	28						$n_{2 \text{ th}}$			
378			452	378							M_2			
1.4			1.6	1.4							c	0.89	720	61.25
58			25	59							$n_{2 \text{ Eck}}$			
58			24	59							$n_{2 \text{ th}}$			
437											M_2			
1.3											c	0.61	720	70.611
50											$n_{2 \text{ Eck}}$			
50											$n_{2 \text{ th}}$			
490											M_2			
1.2											c	0.57	720	79.722
44											$n_{2 \text{ Eck}}$			
44											$n_{2 \text{ th}}$			

M ... [Nm]
n ... [min⁻¹]
J ... [kgcm²]

P ... [kW]
I ... [A]
i [-]
c [-]

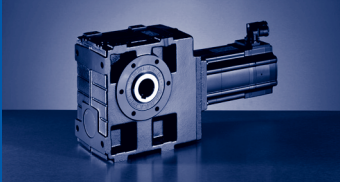

GSS [Nm]

GSS□□-□S (MCS)

$M_{2GN} \leq 720 \text{ Nm}$

GSS06-2S				06FC41	06IC41	09DC41	09FC38	09HC41	09LC41	12DC20	12DC41	12HC15	12HC30
				...500	...500	...500	...500	...500	...500	...500	...500	...500	...500
i	M_{2GN}	J_G	M_1	1.2	1.5	2.3	3.1	3.8	4.5	5.5	4.3	10	8
			n_1	4050	4050	4050	3750	4050	4050	1950	4050	1500	3000
			I_{M230}	2.9	3.2	4.6	5	6.8	8.4	5.2	8.8	7.6	10.5
			I_{M400}	1.5	1.6	2.3	2.5	3.4	4.2	2.6	4.5	3.8	
			P_N	0.51	0.64	1	1.2	1.6	1.9	1.1	1.8	1.6	2.5
			J_M	0.25	0.33	1.13	1.53	1.93	2.83	4.12	4.12	7.42	7.42
87.833	684	0.44	M_2 c n_2 Eck n_2 th		103 5.6 46 46								
87.833	720	0.44	M_2 c n_2 Eck n_2 th			162 3.7 46 46	220 2.7 43 43	272 2.2 46 46	323 1.9 46 46	389 1.8 22 22	308 2 46 46	702 1 17 17	577 1.2 34 34
99.167	720	0.42	M_2 c n_2 Eck n_2 th		116 5.1 41 41	181 3.3 41 41	247 2.5 38 38	304 2 41 41	362 1.7 41 41	434 1.7 20 20	345 1.8 41 41		645 1.1 30 30
113.667	699	0.28	M_2 c n_2 Eck n_2 th	105 5.9 36 36	134 4.8 36 36								
113.667	720	0.28	M_2 c n_2 Eck n_2 th			209 3.1 36 36	285 2.3 33 33	351 1.9 36 36	417 1.6 36 36				
128.333	720	0.26	M_2 c n_2 Eck n_2 th	118 5.4 32 32	150 4.3 32 32	234 2.8 32 32	319 2.1 29 29	393 1.7 32 32	466 1.4 32 32				
137.95	700	0.2	M_2 c n_2 Eck n_2 th	128 5.3 29 29	162 4.2 29 29								
137.95	720	0.2	M_2 c n_2 Eck n_2 th			253 2.7 29 29	345 2 27 27	424 1.7 29 29	504 1.4 29 29				
155.75	720	0.19	M_2 c n_2 Eck n_2 th	144 4.8 26 26	182 3.8 26 26	283 2.5 26 26	385 1.8 24 24	474 1.5 26 26	563 1.3 26 26				
174.375	681	0.13	M_2 c n_2 Eck n_2 th	162 4.2 23 23	205 3.4 23 23								
196.875	720	0.12	M_2 c n_2 Eck n_2 th	182 3.8 21 21	229 3 21 21								

$M \dots$ [Nm]
 $n \dots$ [min^{-1}]
 $J \dots$ [kgcm^2]

$P \dots$ [kW]
 $I \dots$ [A]
 $i \dots$ [-]
 $c \dots$ [-]

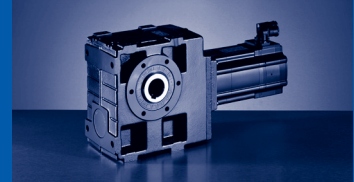

$M_{2GN} \leq 720 \text{ Nm}$

12HC35	12LC20	12LC41	14DC15	14DC36	14HC15	14HC32	14LC15	14LC32	14PC14	14PC32	GSS06-2S			
...S00	...S00	...S00	...S00	...S00	...S00	...S00	...S00	...S00	...S00	...S00	M_1	J_G	M_{2GN}	i
7.5	13.5	11	9.2	7.5	16	14	23	17.2	30	21	n_1			
3525	1950	4050	1500	3600	1500	3225	1500	3225	1350	3225	I_{M230}			
	11.8										I_{M400}			
5.7	5.9	10.2	4.5	7.5	6.6	11.9	9.7	15	10.8	15.6	P_N			
2.8	2.8	4.7	1.45	2.8	2.5	4.7	3.6	5.8	4.2	7.1	J_M			
7.42	10.72	10.72	8.22	8.22	14.32	14.32	23.44	23.44	34.74	34.82	M_2			
											c	0.44	684	87.833
											n_2 Eck			
											n_2 th			
543											M_2			
1.2											c	0.44	720	87.833
40											n_2 Eck			
40											n_2 th			
607											M_2			
1.1											c	0.42	720	99.167
36											n_2 Eck			
36											n_2 th			
											M_2			
											c	0.28	699	113.667
											n_2 Eck			
											n_2 th			
											M_2			
											c	0.28	720	113.667
											n_2 Eck			
											n_2 th			
											M_2			
											c	0.26	720	128.333
											n_2 Eck			
											n_2 th			
											M_2			
											c	0.2	700	137.95
											n_2 Eck			
											n_2 th			
											M_2			
											c	0.2	720	137.95
											n_2 Eck			
											n_2 th			
											M_2			
											c	0.19	720	155.75
											n_2 Eck			
											n_2 th			
											M_2			
											c	0.13	681	174.375
											n_2 Eck			
											n_2 th			
											M_2			
											c	0.12	720	196.875
											n_2 Eck			
											n_2 th			

M ... [Nm]
n ... [min⁻¹]
J ... [kgcm²]

P ... [kW]
I ... [A]
i [-]
c [-]

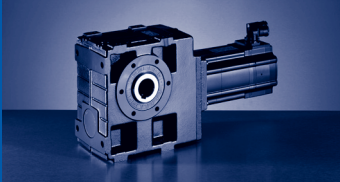

GSS [Nm]

GSS□□-□S (MCS)

$M_{2GN} \leq 720 \text{ Nm}$

GSS06-3S				06CC41	06FC41	06IC41	09DC41	09FC38	09HC41
				...500	...500	...500	...500	...500	...500
i	M_{2GN}	J_G	M_1	0.6	1.2	1.5	2.3	3.1	3.8
			n_1	4050	4050	4050	4050	3750	4050
			I_{M230}	2.6	2.9	3.2	4.6	5	6.8
			I_{M400}	1.3	1.5	1.6	2.3	2.5	3.4
			P_N	0.25	0.51	0.64	1	1.2	1.6
			J_M	0.17	0.25	0.33	1.13	1.53	1.93
126.531	720	0.31	M_2		116	146	226	306	376
			c		3.2	2.5	1.7	1.2	1
			$n_{2 \text{ Eck}}$		32	32	32	30	32
			$n_{2 \text{ th}}$		32	32	32	30	32
142.857	720	0.3	M_2		129	162	252	341	419
			c		3.2	2.5	1.7	1.2	1
			$n_{2 \text{ Eck}}$		28	28	28	26	28
			$n_{2 \text{ th}}$		28	28	28	26	28
155	720	0.27	M_2	68	141	178	275	372	
			c	5.6	2.8	2.3	1.5	1.1	
			$n_{2 \text{ Eck}}$	26	26	26	26	24	
			$n_{2 \text{ th}}$	26	26	26	26	24	
175	720	0.26	M_2	76	157	197	306	414	
			c	5.6	2.8	2.3	1.5	1.1	
			$n_{2 \text{ Eck}}$	23	23	23	23	21	
			$n_{2 \text{ th}}$	23	23	23	23	21	
194.857	720	0.14	M_2	85	176	222			
			c	4.7	2.4	1.9			
			$n_{2 \text{ Eck}}$	21	21	21			
			$n_{2 \text{ th}}$	21	21	21			
220	720	0.14	M_2	95	196	246			
			c	4.7	2.4	1.9			
			$n_{2 \text{ Eck}}$	18	18	18			
			$n_{2 \text{ th}}$	18	18	18			
238.7	720	0.13	M_2	104	214	269			
			c	4.2	2.1	1.7			
			$n_{2 \text{ Eck}}$	17	17	17			
			$n_{2 \text{ th}}$	17	17	17			
269.5	720	0.12	M_2	116	238	299			
			c	4.2	2.1	1.7			
			$n_{2 \text{ Eck}}$	15	15	15			
			$n_{2 \text{ th}}$	15	15	15			
310.689	720	0.11	M_2	136	277	348			
			c	2.8	1.4	1.1			
			$n_{2 \text{ Eck}}$	13	13	13			
			$n_{2 \text{ th}}$	13	13	13			
350.778	720	0.11	M_2	151	307	385			
			c	2.8	1.4	1.1			
			$n_{2 \text{ Eck}}$	12	12	12			
			$n_{2 \text{ th}}$	12	12	12			
386.467	720	0.1	M_2	168	341				
			c	2.4	1.2				
			$n_{2 \text{ Eck}}$	11	11				
			$n_{2 \text{ th}}$	10	10				
436.333	720	0.1	M_2	186	379				
			c	2.4	1.2				
			$n_{2 \text{ Eck}}$	9	9				
			$n_{2 \text{ th}}$	9	9				
497.722	720	0.07	M_2	214	434				
			c	2	1				
			$n_{2 \text{ Eck}}$	8	8				
			$n_{2 \text{ th}}$	8	8				

$M \dots [\text{Nm}]$
 $n \dots [\text{min}^{-1}]$
 $J \dots [\text{kgcm}^2]$

$P \dots [\text{kW}]$
 $I \dots [\text{A}]$
 $i \dots [-]$
 $c \dots [-]$

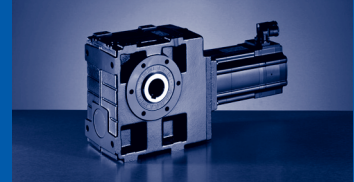

$M_{2GN} \leq 720 \text{ Nm}$

GSS06-3S				06CC41	06FC41	06IC41	09DC41	09FC38	09HC41
				...S00	...S00	...S00	...S00	...S00	...S00
i	M_{2GN}	J_G	M_1	0.6	1.2	1.5	2.3	3.1	3.8
			n_1	4050	4050	4050	4050	3750	4050
			I_{M230}	2.6	2.9	3.2	4.6	5	6.8
			I_{M400}	1.3	1.5	1.6	2.3	2.5	3.4
			P_N	0.25	0.51	0.64	1	1.2	1.6
			J_M	0.17	0.25	0.33	1.13	1.53	1.93
561.944	720	0.07	M_2	238	482				
			c	2	1				
			$n_{2 \text{ Eck}}$	7	7				
			$n_{2 \text{ th}}$	7	7				

M ... [Nm]
n ... [min^{-1}]
J ... [kgcm^2]

P ... [kW]
I ... [A]
i [-]
c [-]

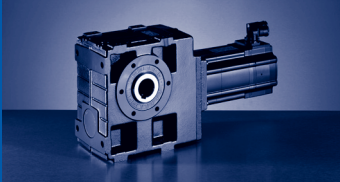

GSS [Nm]

GSS□□-□S (MCS)

$M_{2GN} \leq 1250 \text{ Nm}$

GSS07-2S				09DC41	09FC38	09HC41	09LC41	12DC20	12DC41	12HC15	12HC30	12HC35	12LC20	12LC41	14DC15
				...500	...500	...500	...500	...500	...500	...500	...500	...500	...500	...500	...500
i	M_{2GN}	J_G	M_1	2.3	3.1	3.8	4.5	5.5	4.3	10	8	7.5	13.5	11	9.2
			n_1	4050	3750	4050	4050	1950	4050	1500	3000	3525	1950	4050	1500
			I_{M230}	4.6	5	6.8	8.4	5.2	8.8	7.6	10.5		11.8		
			I_{M400}	2.3	2.5	3.4	4.2	2.6	4.5	3.8		5.7	5.9	10.2	4.5
			P_N	1	1.2	1.6	1.9	1.1	1.8	1.6	2.5	2.8	2.8	4.7	1.45
			J_M	1.13	1.53	1.93	2.83	4.12	4.12	7.42	7.42	7.42	10.72	10.72	8.22
5.862	539	21.36	M_2 c $n_{2 \text{ Eck}}$ $n_{2 \text{ th}}$												
8.125	685	12.75	M_2 c $n_{2 \text{ Eck}}$ $n_{2 \text{ th}}$												
9.086	628	17.44	M_2 c $n_{2 \text{ Eck}}$ $n_{2 \text{ th}}$												
10	468	9.14	M_2 c $n_{2 \text{ Eck}}$ $n_{2 \text{ th}}$							89 5 150 150			122 3.7 195 195	99 3.8 405 405	
10	734	9.14	M_2 c $n_{2 \text{ Eck}}$ $n_{2 \text{ th}}$												
10	797	9.14	M_2 c $n_{2 \text{ Eck}}$ $n_{2 \text{ th}}$												
11.2	496	7.5	M_2 c $n_{2 \text{ Eck}}$ $n_{2 \text{ th}}$							100 4.8 134 134	79 6 268 268	74 5.9 315 315	137 3.5 174 174	111 3.7 362 362	
11.2	771	7.5	M_2 c $n_{2 \text{ Eck}}$ $n_{2 \text{ th}}$												
11.2	866	7.5	M_2 c $n_{2 \text{ Eck}}$ $n_{2 \text{ th}}$												
12.594	799	10.71	M_2 c $n_{2 \text{ Eck}}$ $n_{2 \text{ th}}$												
14.286	533	4.84	M_2 c $n_{2 \text{ Eck}}$ $n_{2 \text{ th}}$							129 4 105 105	101 5 210 210	95 5.4 247 247	175 3 137 137	142 3.4 284 284	
14.286	737	4.84	M_2 c $n_{2 \text{ Eck}}$ $n_{2 \text{ th}}$												
15.5	704	7.79	M_2 c $n_{2 \text{ Eck}}$ $n_{2 \text{ th}}$							134 5 97 97	107 5 194 194	101 4.7 227 227	183 3.7 126 126	151 3 261 261	

$M \dots$ [Nm]
 $n \dots$ [min^{-1}]
 $J \dots$ [kgcm^2]

$P \dots$ [kW]
 $I \dots$ [A]
 $i \dots$ [-]
 $c \dots$ [-]

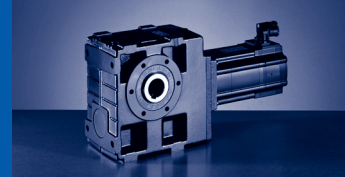

$M_{2GN} \leq 1250 \text{ Nm}$

14DC36	14HC15	14HC32	14LC15	14LC32	14PC14	14PC32	19FC14	19FC30	19JC14	19JC30	19PC14	19PC30	GSS07-2S			
...S00	...S00	...S00	...S00	...S00	...S00	...S00	...S00	...S00	...S00	...S00	...S00	...S00	M_1	J_G	M_{2GN}	i
7.5	16	14	23	17.2	30	21	27	21	40	29	51	32	n_1			
3600	1500	3225	1500	3225	1350	3225	1425	3000	1425	3000	1350	3000	I_{M230}			
													I_{M400}			
7.5	6.6	11.9	9.7	15	10.8	15.6	8.6	14	12.3	18.5	14.3	19	P_N			
2.8	2.5	4.7	3.6	5.8	4.2	7.1	4	6.6	6	9.1	7.2	10	J_M			
8.22	14.32	14.32	23.44	23.44	34.74	34.82	65.12	65.04	105.04	105.12	160.12	160.04	M_2			
		73	120	91	159	111	142	111	214	155	274	171	c	21.36	539	5.862
		3.8	4.3	3.1	3.3	2.5	3.7	2.9	2.5	2.1	2	1.9	$n_{2 \text{ Eck}}$			
		550	256	550	230	550	243	512	243	512	230	512	$n_{2 \text{ th}}$			
		550	256	550	230	550	243	377	243	377	230	377				
53	115	102	168	126	221	155	198	155	298	216	381	238	M_2	12.75	685	8.125
5.9	5.7	3.4	4	2.8	3	2.3	3.4	2.6	2.3	1.9	1.8	1.7	c			
443	185	397	185	397	166	397	175	369	175	369	166	369	$n_{2 \text{ Eck}}$			
442	185	397	185	397	166	397	175	272	175	272	166	272	$n_{2 \text{ th}}$			
58	126	112	184	139	242	170	217	170	325	236	417	261	M_2	17.44	628	9.086
5.7	4.8	3.3	3.3	2.7	2.6	2.2	2.8	2.4	1.9	1.7	1.5	1.6	c			
396	165	355	165	355	149	355	157	330	157	330	149	330	$n_{2 \text{ Eck}}$			
395	165	355	165	355	149	355	157	243	157	243	149	243	$n_{2 \text{ th}}$			
													M_2	9.14	468	10
													c			
													$n_{2 \text{ Eck}}$			
													$n_{2 \text{ th}}$			
66	142	126	208	156	274	192							M_2	9.14	734	10
5.5	4.9	3.3	3.4	2.6	2.6	2.2							c			
360	150	323	150	323	135	323							$n_{2 \text{ Eck}}$			
359	150	323	150	323	135	323							$n_{2 \text{ th}}$			
							245	191	367	266	470	294	M_2	9.14	797	10
							3.2	2.5	2.2	1.8	1.7	1.6	c			
							143	300	143	300	135	300	$n_{2 \text{ Eck}}$			
							143	221	143	221	135	221	$n_{2 \text{ th}}$			
													M_2	7.5	496	11.2
													c			
													$n_{2 \text{ Eck}}$			
													$n_{2 \text{ th}}$			
74	160	142	234	175	307	215							M_2	7.5	771	11.2
5.4	4.6	3.2	3.2	2.6	2.5	2.1							c			
321	134	288	134	288	121	288							$n_{2 \text{ Eck}}$			
321	134	288	134	288	121	288							$n_{2 \text{ th}}$			
							275	215	411	298	527	330	M_2	7.5	866	11.2
							3.1	2.4	2.1	1.7	1.6	1.6	c			
							127	268	127	268	121	268	$n_{2 \text{ Eck}}$			
							127	197	127	197	121	197	$n_{2 \text{ th}}$			
82	175	156	256	193	336	237	302	237	451	329	578	363	M_2	10.71	799	12.594
4.9	4.4	2.8	3.1	2.3	2.3	1.9	2.6	2.1	1.8	1.5	1.4	1.4	c			
286	119	256	119	256	107	256	113	238	113	238	107	238	$n_{2 \text{ Eck}}$			
285	119	256	119	256	107	256	113	176	113	176	107	176	$n_{2 \text{ th}}$			
													M_2	4.84	533	14.286
													c			
													$n_{2 \text{ Eck}}$			
													$n_{2 \text{ th}}$			
95	207	181	301	224	395	275							M_2	4.84	737	14.286
5	3.5	2.9	2.4	2.4	1.9	2							c			
252	105	226	105	226	95	226							$n_{2 \text{ Eck}}$			
251	105	226	105	226	95	226							$n_{2 \text{ th}}$			
													M_2	7.79	704	15.5
													c			
													$n_{2 \text{ Eck}}$			
													$n_{2 \text{ th}}$			

$M \dots$ [Nm]
 $n \dots$ [min^{-1}]
 $J \dots$ [kgcm^2]

$P \dots$ [kW]
 $I \dots$ [A]
 i [-]
 c [-]

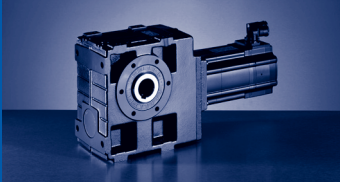

GSS [Nm]

GSS□□-□S (MCS)

$M_{2GN} \leq 1250 \text{ Nm}$

GSS07-2S				09DC41	09FC38	09HC41	09LC41	12DC20	12DC41	12HC15	12HC30	12HC35	12LC20	12LC41	14DC15
				...500	...500	...500	...500	...500	...500	...500	...500	...500	...500	...500	...500
i	M_{2GN}	J_G	M_1	2.3	3.1	3.8	4.5	5.5	4.3	10	8	7.5	13.5	11	9.2
			n_1	4050	3750	4050	4050	1950	4050	1500	3000	3525	1950	4050	1500
			I_{M230}	4.6	5	6.8	8.4	5.2	8.8	7.6	10.5		11.8		
			I_{M400}	2.3	2.5	3.4	4.2	2.6	4.5	3.8		5.7	5.9	10.2	4.5
			P_N	1	1.2	1.6	1.9	1.1	1.8	1.6	2.5	2.8	2.8	4.7	1.45
			J_M	1.13	1.53	1.93	2.83	4.12	4.12	7.42	7.42	7.42	10.72	10.72	8.22
15.5	931	7.79	M_2 c $n_{2 \text{ Eck}}$ $n_{2 \text{ th}}$												
17.36	746	6.42	M_2 c $n_{2 \text{ Eck}}$ $n_{2 \text{ th}}$							150 4.8 86 86	120 4.8 173 173	113 4.5 203 203	206 3.5 112 112	169 2.9 233 233	
17.36	1012	6.42	M_2 c $n_{2 \text{ Eck}}$ $n_{2 \text{ th}}$												
20.517	764	13.58	M_2 c $n_{2 \text{ Eck}}$ $n_{2 \text{ th}}$												152 4.8 73 73
22.143	797	4.18	M_2 c $n_{2 \text{ Eck}}$ $n_{2 \text{ th}}$							192 4 68 68	154 4.5 136 135	145 4.2 159 159	264 3 88 88	216 2.6 183 183	
22.143	1103	4.18	M_2 c $n_{2 \text{ Eck}}$ $n_{2 \text{ th}}$												
25.188	913	9.59	M_2 c $n_{2 \text{ Eck}}$ $n_{2 \text{ th}}$												189 4.6 60 60
27.125	837	3.13	M_2 c $n_{2 \text{ Eck}}$ $n_{2 \text{ th}}$							236 3.5 55 55	189 4.3 111 111	178 4 130 130	324 2.6 72 72	265 2.5 149 149	
27.125	1250	3.13	M_2 c $n_{2 \text{ Eck}}$ $n_{2 \text{ th}}$												212 5.6 55 55
31	1065	7.05	M_2 c $n_{2 \text{ Eck}}$ $n_{2 \text{ th}}$					137 5.7 63 63	109 4.7 131 131	254 4.1 48 48	206 3 97 97	194 2.9 114 114	351 2.3 63 63	288 1.8 131 131	233 4.4 48 48
35.306	676	1.96	M_2 c $n_{2 \text{ Eck}}$ $n_{2 \text{ th}}$			115 5.7 115 115	137 4.8 115 115								
35.306	870	1.96	M_2 c $n_{2 \text{ Eck}}$ $n_{2 \text{ th}}$					166 5 55 55	130 6 115 115	309 2.8 43 42	248 3.5 85 85	232 3.7 100 100	422 2.1 55 55	345 2.3 115 115	
35.306	1250	1.96	M_2 c $n_{2 \text{ Eck}}$ $n_{2 \text{ th}}$												279 4.3 43 42

$M \dots$ [Nm]
 $n \dots$ [min^{-1}]
 $J \dots$ [kgcm^2]

$P \dots$ [kW]
 $I \dots$ [A]
 $i \dots$ [-]
 $c \dots$ [-]

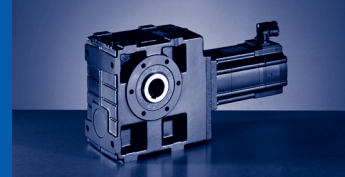

$M_{2GN} \leq 1250 \text{ Nm}$

14DC36	14HC15	14HC32	14LC15	14LC32	14PC14	14PC32	19FC14	19FC30	19JC14	19JC30	19PC14	19PC30	GSS07-2S			
...500	...500	...500	...500	...500	...500	...500	...500	...500	...500	...500	...500	...500				
7.5	16	14	23	17.2	30	21	27	21	40	29	51	32	M_1	J_G	M_{2GN}	i
3600	1500	3225	1500	3225	1350	3225	1425	3000	1425	3000	1350	3000	n_1			
													I_{M230}			
7.5	6.6	11.9	9.7	15	10.8	15.6	8.6	14	12.3	18.5	14.3	19	I_{M400}			
2.8	2.5	4.7	3.6	5.8	4.2	7.1	4	6.6	6	9.1	7.2	10	P_N			
8.22	14.32	14.32	23.44	23.44	34.74	34.82	65.12	65.04	105.04	105.12	160.12	160.04	J_M			
101	216	193	315	238	414	292	372	292	555	405	711	447	M_2			
4.4	4.2	2.5	2.9	2.1	2.2	1.7	2.5	1.9	1.7	1.4	1.3	1.3	c	7.79	931	15.5
232	97	208	97	208	87	208	92	194	92	194	87	194	n_{2Eck}			
232	97	208	97	208	87	208	92	143	92	143	87	143	n_{2th}			
													M_2			
													c	6.42	746	17.36
													n_{2Eck}			
													n_{2th}			
114	242	216	353	267	463	328	416	327	622	454	796	501	M_2			
4.2	4	2.4	2.8	2	2.2	1.6	2.4	1.8	1.6	1.3	1.3	1.2	c	6.42	1012	17.36
207	86	186	86	186	78	186	82	173	82	173	78	173	n_{2Eck}			
207	86	186	86	186	78	186	82	127	82	127	78	127	n_{2th}			
126	272	240	394	296	517	362	465	362	693				M_2			
3.3	2.8	1.9	1.9	1.5	1.5	1.3	1.6	1.4	1.1				c	13.58	764	20.517
176	73	157	73	157	66	157	70	146	70				n_{2Eck}			
175	73	157	73	157	66	157	69	108	69				n_{2th}			
													M_2			
													c	4.18	797	22.143
													n_{2Eck}			
													n_{2th}			
145	309	276	450	341	591	418							M_2			
3.9	3.5	2.3	2.4	1.8	1.9	1.5							c	4.18	1103	22.143
163	68	146	68	146	61	146							n_{2Eck}			
162	68	146	68	146	61	146							n_{2th}			
157	336	298	488	367	639	450	574	449	856				M_2			
3	2.7	1.7	1.9	1.4	1.4	1.1	1.6	1.2	1.1				c	9.59	913	25.188
143	60	128	60	128	54	128	57	119	57				n_{2Eck}			
143	60	128	60	128	54	128	57	88	57				n_{2th}			
													M_2			
													c	3.13	837	27.125
													n_{2Eck}			
													n_{2th}			
178	379	339	551	418	723	512							M_2			
3.7	3.2	2.2	2.2	1.8	1.7	1.4							c	3.13	1250	27.125
133	55	119	55	119	50	119							n_{2Eck}			
132	55	119	55	119	50	119							n_{2th}			
194	414	367	600	453	786	555	706	554	1052				M_2			
2.7	2.5	1.5	1.8	1.3	1.4	1	1.5	1.2	1				c	7.05	1065	31
116	48	104	48	104	44	104	46	97	46				n_{2Eck}			
116	48	104	48	104	44	104	46	71	46				n_{2th}			
													M_2			
													c	1.96	676	35.306
													n_{2Eck}			
													n_{2th}			
													M_2			
													c	1.96	870	35.306
													n_{2Eck}			
													n_{2th}			
233	495	441	718	544	941	667							M_2			
3.4	2.5	2	1.7	1.6	1.3	1.3							c	1.96	1250	35.306
102	43	91	43	91	38	91							n_{2Eck}			
102	42	91	42	91	38	91							n_{2th}			

M ... [Nm]
n ... [min⁻¹]
J ... [kgcm²]

P ... [kW]
I ... [A]
i [-]
c [-]

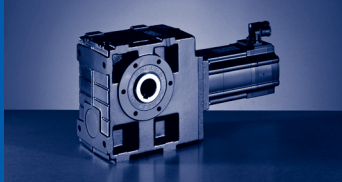

GSS [Nm]

GSS□□-□S (MCS)

$M_{2GN} \leq 1250 \text{ Nm}$

GSS07-2S				09DC41	09FC38	09HC41	09LC41	12DC20	12DC41	12HC15	12HC30	12HC35	12LC20	12LC41	14DC15
				...500	...500	...500	...500	...500	...500	...500	...500	...500	...500	...500	...500
i	M_{2GN}	J_G	M_1	2.3	3.1	3.8	4.5	5.5	4.3	10	8	7.5	13.5	11	9.2
			n_1	4050	3750	4050	4050	1950	4050	1500	3000	3525	1950	4050	1500
			I_{M230}	4.6	5	6.8	8.4	5.2	8.8	7.6	10.5		11.8		
			I_{M400}	2.3	2.5	3.4	4.2	2.6	4.5	3.8		5.7	5.9	10.2	4.5
			P_N	1	1.2	1.6	1.9	1.1	1.8	1.6	2.5	2.8	2.8	4.7	1.45
			J_M	1.13	1.53	1.93	2.83	4.12	4.12	7.42	7.42	7.42	10.72	10.72	8.22
39.2	1175	5.37	M_2					172	137	319	260	244	440	362	292
			c				5.3	4.2	3.6	2.8	2.6	2.2	1.6	3.9	
			$n_{2 \text{ Eck}}$				50	103	38	77	90	50	103	38	
			$n_{2 \text{ th}}$				50	103	38	77	90	50	103	38	
43.271	706	1.43	M_2		114	142	169								
			c		5.9	4.8	4.1								
			$n_{2 \text{ Eck}}$		87	94	94								
			$n_{2 \text{ th}}$		87	94	94								
43.271	908	1.43	M_2					205	159	378	304	285	518	423	
			c					4.3	5.5	2.4	3	3.2	1.8	2.2	
			$n_{2 \text{ Eck}}$					45	94	35	69	82	45	94	
			$n_{2 \text{ th}}$					45	94	35	69	81	45	94	
43.271	1250	1.43	M_2												343
			c												3.5
			$n_{2 \text{ Eck}}$												35
			$n_{2 \text{ th}}$												35
50	1250	3.53	M_2		124	154	184	220	176	407	331	311	560	462	374
			c		5.4	4.4	3.7	4.9	3.9	3	2.6	2.4	2	1.5	3.3
			$n_{2 \text{ Eck}}$		75	81	81	39	81	30	60	71	39	81	30
			$n_{2 \text{ th}}$		75	81	81	39	81	30	60	71	39	81	30
54.25	1250	2.89	M_2					241	192	446	362	341	613	505	409
			c					4.8	3.9	2.8	2.6	2.4	1.9	1.5	3
			$n_{2 \text{ Eck}}$					36	75	28	55	65	36	75	28
			$n_{2 \text{ th}}$					36	75	28	55	65	36	75	28
61.25	1250	2.7	M_2					271	215	500	405	381	686	565	459
			c					4.3	3.7	2.5	2.5	2.3	1.8	1.4	2.7
			$n_{2 \text{ Eck}}$					32	66	25	49	58	32	66	25
			$n_{2 \text{ th}}$					32	66	24	49	58	32	66	24
70.611	1250	1.81	M_2		177	220	262	316	250	579	471	443	796	656	531
			c		5	4.1	3.5	3.8	3.6	2.1	2.4	2.3	1.6	1.4	2.3
			$n_{2 \text{ Eck}}$		53	57	57	28	57	21	43	50	28	57	21
			$n_{2 \text{ th}}$		53	57	57	28	57	21	42	50	28	57	21
79.722	1250	1.7	M_2		199	246	293	354	280	649	527	496	891	734	596
			c		4.8	3.9	3.3	3.4	3.4	1.9	2.2	2.2	1.4	1.3	2.1
			$n_{2 \text{ Eck}}$		47	51	51	25	51	19	38	44	25	51	19
			$n_{2 \text{ th}}$		47	51	51	24	51	19	38	44	24	51	19
86.542	1250	1.34	M_2		217	269	321	387	306	707	577	543	972	803	649
			c		4.8	3.9	3.3	3.2	3.5	1.8	2.1	2.1	1.3	1.4	1.9
			$n_{2 \text{ Eck}}$		43	47	47	23	47	17	35	41	23	47	17
			$n_{2 \text{ th}}$		43	47	47	23	47	17	35	41	23	47	17
97.708	1250	1.26	M_2		244	302	360	435	343	791	646	608	1089	898	727
			c		4.5	3.6	3.1	2.8	3.2	1.6	1.9	1.9	1.2	1.3	1.7
			$n_{2 \text{ Eck}}$		38	42	42	20	42	15	31	36	20	42	15
			$n_{2 \text{ th}}$		38	41	41	20	41	15	31	36	20	41	15
113.667	1250	0.83	M_2	208	286	354	422	508	402	924	756	712		1051	
			c	5.6	4.1	3.4	2.9	2.4	3	1.4	1.6	1.7		1.2	
			$n_{2 \text{ Eck}}$	36	33	36	36	17	36	13	26	31		36	
			$n_{2 \text{ th}}$	36	33	36	36	17	36	13	26	31		36	
128.333	1250	0.79	M_2	234	321	397	472	569	451	1030	847	797		1176	
			c	5.1	3.8	3.1	2.6	2.2	2.7	1.2	1.5	1.6		1.1	
			$n_{2 \text{ Eck}}$	32	29	32	32	15	32	12	23	28		32	
			$n_{2 \text{ th}}$	32	29	32	32	15	32	12	23	27		32	

$M \dots$ [Nm]
 $n \dots$ [min^{-1}]
 $J \dots$ [kgcm^2]

$P \dots$ [kW]
 $I \dots$ [A]
 $i \dots$ [-]
 $c \dots$ [-]

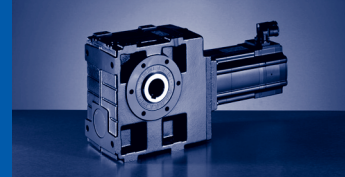

$M_{2GN} \leq 1250 \text{ Nm}$

14DC36	14HC15	14HC32	14LC15	14LC32	14PC14	14PC32	19FC14	19FC30	19JC14	19JC30	19PC14	19PC30	GSS07-2S			
...500	...500	...500	...500	...500	...500	...500	...500	...500	...500	...500	...500	...500	M_1	J_G	M_{2GN}	i
7.5	16	14	23	17.2	30	21	27	21	40	29	51	32	n_1			
3600	1500	3225	1500	3225	1350	3225	1425	3000	1425	3000	1350	3000	I_{M230}			
7.5	6.6	11.9	9.7	15	10.8	15.6	8.6	14	12.3	18.5	14.3	19	I_{M400}			
2.8	2.5	4.7	3.6	5.8	4.2	7.1	4	6.6	6	9.1	7.2	10	P_N			
8.22	14.32	14.32	23.44	23.44	34.74	34.82	65.12	65.04	105.04	105.12	160.12	160.04	J_M			
245	518	462	751	569	984		884	695					M_2			
2.4	2.2	1.4	1.6	1.1	1.2		1.3	1.1					c	5.37	1175	39.2
92	38	82	38	82	34		36	77					$n_{2\text{ Eck}}$			
92	38	82	38	82	34		36	56					$n_{2\text{ th}}$			
													M_2			
													c	1.43	706	43.271
													$n_{2\text{ Eck}}$			
													$n_{2\text{ th}}$			
													M_2			
													c	1.43	908	43.271
													$n_{2\text{ Eck}}$			
													$n_{2\text{ th}}$			
285	607	540	879	666	1150	816							M_2			
3.3	2	1.9	1.4	1.6	1.1	1.3							c	1.43	1250	43.271
83	35	75	35	75	31	75							$n_{2\text{ Eck}}$			
83	35	75	35	75	31	75							$n_{2\text{ th}}$			
312	661	589	956	726									M_2			
2.2	1.9	1.3	1.3	1.1									c	3.53	1250	50
72	30	65	30	65									$n_{2\text{ Eck}}$			
72	30	65	30	65									$n_{2\text{ th}}$			
342	722	645	1044	794									M_2			
2.2	1.7	1.3	1.2	1.1									c	2.89	1250	54.25
66	28	60	28	60									$n_{2\text{ Eck}}$			
66	28	59	28	59									$n_{2\text{ th}}$			
382	809	721	1169	888									M_2			
2.1	1.5	1.2	1.1	1									c	2.7	1250	61.25
59	25	53	25	53									$n_{2\text{ Eck}}$			
59	24	53	24	53									$n_{2\text{ th}}$			
444	935	837											M_2			
2.1	1.3	1.2											c	1.81	1250	70.611
51	21	46											$n_{2\text{ Eck}}$			
51	21	46											$n_{2\text{ th}}$			
497	1047	936											M_2			
2	1.2	1.2											c	1.7	1250	79.722
45	19	41											$n_{2\text{ Eck}}$			
45	19	40											$n_{2\text{ th}}$			
544	1140	1025											M_2			
2	1.1	1.1											c	1.34	1250	86.542
42	17	37											$n_{2\text{ Eck}}$			
41	17	37											$n_{2\text{ th}}$			
608		1146											M_2			
1.9		1											c	1.26	1250	97.708
37		33											$n_{2\text{ Eck}}$			
37		33											$n_{2\text{ th}}$			
													M_2			
													c	0.83	1250	113.667
													$n_{2\text{ Eck}}$			
													$n_{2\text{ th}}$			
													M_2			
													c	0.79	1250	128.333
													$n_{2\text{ Eck}}$			
													$n_{2\text{ th}}$			

$M \dots$ [Nm]
 $n \dots$ [min^{-1}]
 $J \dots$ [kgcm^2]

$P \dots$ [kW]
 $I \dots$ [A]
 i [-]
 c [-]

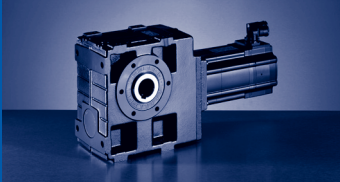

GSS [Nm]

GSS□□-□S (MCS)

$M_{2GN} \leq 1250 \text{ Nm}$

GSS07-2S				09DC41	09FC38	09HC41	09LC41	12DC20	12DC41	12HC15	12HC30	12HC35	12LC20	12LC41	14DC15
				...S00	...S00	...S00	...S00	...S00	...S00	...S00	...S00	...S00	...S00	...S00	...S00
i	M_{2GN}	J_G	M_1	2.3	3.1	3.8	4.5	5.5	4.3	10	8	7.5	13.5	11	9.2
			n_1	4050	3750	4050	4050	1950	4050	1500	3000	3525	1950	4050	1500
			I_{M230}	4.6	5	6.8	8.4	5.2	8.8	7.6	10.5		11.8		
			I_{M400}	2.3	2.5	3.4	4.2	2.6	4.5	3.8		5.7	5.9	10.2	4.5
			P_N	1	1.2	1.6	1.9	1.1	1.8	1.6	2.5	2.8	2.8	4.7	1.45
			J_M	1.13	1.53	1.93	2.83	4.12	4.12	7.42	7.42	7.42	10.72	10.72	8.22
137.95	1250	0.61	M_2	254	348	429	511	615	488	1116	914	862			
			c	4.7	3.5	2.8	2.4	2	2.5	1.1	1.4	1.4			
			$n_{2 \text{ Eck}}$	29	27	29	29	14	29	11	22	26			
			$n_{2 \text{ th}}$	29	27	29	29	14	29	11	22	26			
155.75	1250	0.58	M_2	286	390	482	573	687	547	1241	1024	965			
			c	4.2	3.1	2.5	2.1	1.8	2.2	1	1.2	1.3			
			$n_{2 \text{ Eck}}$	26	24	26	26	13	26	10	19	23			
			$n_{2 \text{ th}}$	26	24	26	26	13	26	10	19	23			
174.375	1250	0.39	M_2	322	439	542	644								
			c	3.7	2.8	2.3	1.9								
			$n_{2 \text{ Eck}}$	23	22	23	23								
			$n_{2 \text{ th}}$	23	22	23	23								
196.875	1250	0.37	M_2	362	493	607	722								
			c	3.3	2.5	2	1.7								
			$n_{2 \text{ Eck}}$	21	19	21	21								
			$n_{2 \text{ th}}$	21	19	21	21								

M ... [Nm]
 n ... [min⁻¹]
 J ... [kgcm²]

P ... [kW]
 I ... [A]
 i [-]
 c [-]

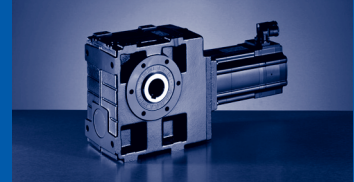

$M_{2GN} \leq 1250 \text{ Nm}$

14DC36	14HC15	14HC32	14LC15	14LC32	14PC14	14PC32	19FC14	19FC30	19JC14	19JC30	19PC14	19PC30	GSS07-2S			
...S00	...S00	...S00	...S00	...S00	...S00	...S00	...S00	...S00	...S00	...S00	...S00	...S00	M_1	J_G	M_{2GN}	i
7.5	16	14	23	17.2	30	21	27	21	40	29	51	32	n_1			
3600	1500	3225	1500	3225	1350	3225	1425	3000	1425	3000	1350	3000	I_{M230}			
7.5	6.6	11.9	9.7	15	10.8	15.6	8.6	14	12.3	18.5	14.3	19	I_{M400}			
2.8	2.5	4.7	3.6	5.8	4.2	7.1	4	6.6	6	9.1	7.2	10	P_N			
8.22	14.32	14.32	23.44	23.44	34.74	34.82	65.12	65.04	105.04	105.12	160.12	160.04	J_M			
													M_2 c	0.61	1250	137.95
													n_2 Eck			
													n_2 th			
													M_2 c	0.58	1250	155.75
													n_2 Eck			
													n_2 th			
													M_2 c	0.39	1250	174.375
													n_2 Eck			
													n_2 th			
													M_2 c	0.37	1250	196.875
													n_2 Eck			
													n_2 th			

M ... [Nm]
n ... [min⁻¹]
J ... [kgcm²]

P ... [kW]
I ... [A]
i [-]
c [-]

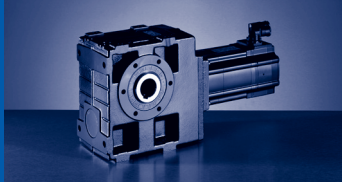

GSS [Nm]

GSS□□-□S (MCS)

$M_{2GN} \leq 1250 \text{ Nm}$

GSS07-3S				06CC41	06FC41	06IC41	09DC41	09FC38	09HC41	09LC41	12DC20	12DC41	12HC15	12HC30	12HC35	
				...S00	...S00	...S00	...S00	...S00	...S00	...S00	...S00	...S00	...S00	...S00	...S00	
i	M_{2GN}	J_G	M_1	0.6	1.2	1.5	2.3	3.1	3.8	4.5	5.5	4.3	10	8	7.5	
			n_1	4050	4050	4050	4050	3750	4050	4050	1950	4050	1500	3000	3525	
			I_{M230}	2.6	2.9	3.2	4.6	5	6.8	8.4	5.2	8.8	7.6	10.5		
			I_{M400}	1.3	1.5	1.6	2.3	2.5	3.4	4.2	2.6	4.5	3.8		5.7	
			P_N	0.25	0.51	0.64	1	1.2	1.6	1.9	1.1	1.8	1.6	2.5	2.8	
			J_M	0.17	0.25	0.33	1.13	1.53	1.93	2.83	4.12	4.12	7.42	7.42	7.42	
126.531	1250	0.86	M_2			145	227	309	381	453	539	432	979	802	761	
			c			5.1	3.3	2.5	2	1.7	2.3	1.8	1.3	1.6	1	
			$n_{2 \text{ Eck}}$			32	32	30	32	32	32	15	32	12	24	28
			$n_{2 \text{ th}}$			32	32	30	32	32	32	15	32	12	24	28
142.857	1250	0.82	M_2			162	254	346	426	507	603	484	1090	899		
			c			4.9	3.2	2.4	1.9	1.6	2.1	1.7	1.2	1.4		
			$n_{2 \text{ Eck}}$			28	28	26	28	28	14	28	11	21		
			$n_{2 \text{ th}}$			28	28	26	28	28	14	28	11	21		
155	1250	0.74	M_2			176	276	376	464	552	658	527	1195	978		
			c			4.9	3.2	2.4	1.9	1.6	1.9	1.7	1.1	1.3		
			$n_{2 \text{ Eck}}$			26	26	24	26	26	13	26	10	19		
			$n_{2 \text{ th}}$			26	26	24	26	26	13	26	10	19		
175	1250	0.72	M_2		156	198	310	422	520	618	734	590		1095		
			c		5.8	4.6	3	2.2	1.8	1.5	1.7	1.6		1.1		
			$n_{2 \text{ Eck}}$		23	23	23	21	23	23	11	23		17		
			$n_{2 \text{ th}}$		23	23	23	21	23	23	11	23		17		
201.746	1250	0.37	M_2		181	229	358	487	600	712						
			c		5.3	4.2	2.8	2.1	1.7	1.4						
			$n_{2 \text{ Eck}}$		20	20	20	19	20	20						
			$n_{2 \text{ th}}$		20	20	20	19	20	20						
227.778	1250	0.36	M_2		203	257	401	545	671	797						
			c		5	4	2.6	2	1.6	1.3						
			$n_{2 \text{ Eck}}$		18	18	18	17	18	18						
			$n_{2 \text{ th}}$		18	18	18	16	18	18						
247.139	1250	0.33	M_2		222	280	437	594	731	868						
			c		4.6	3.7	2.4	1.8	1.5	1.2						
			$n_{2 \text{ Eck}}$		16	16	16	15	16	16						
			$n_{2 \text{ th}}$		16	16	16	15	16	16						
279.028	1250	0.32	M_2		248	313	488	662	815	968						
			c		4.4	3.5	2.3	1.7	1.4	1.2						
			$n_{2 \text{ Eck}}$		15	15	15	13	15	15						
			$n_{2 \text{ th}}$		15	15	15	13	15	15						
321.673	1250	0.28	M_2		291	367	569	771	947							
			c		3.2	2.6	1.7	1.2	1							
			$n_{2 \text{ Eck}}$		13	13	13	12	13							
			$n_{2 \text{ th}}$		13	13	13	12	13							
363.179	1250	0.28	M_2		323	407	631	855	1051							
			c		3.2	2.6	1.7	1.2	1							
			$n_{2 \text{ Eck}}$		11	11	11	10	11							
			$n_{2 \text{ th}}$		11	11	11	10	11							
394.245	1250	0.26	M_2	171	355	447	693	939								
			c	5.7	2.9	2.3	1.5	1.1								
			$n_{2 \text{ Eck}}$	10	10	10	10	10								
			$n_{2 \text{ th}}$	10	10	10	10	10								
445.116	1250	0.26	M_2	189	393	495	767	1038								
			c	5.7	2.9	2.3	1.5	1.1								
			$n_{2 \text{ Eck}}$	9	9	9	9	8								
			$n_{2 \text{ th}}$	9	9	9	9	8								
490.403	1250	0.18	M_2	211	436	548	848									
			c	5	2.5	2	1.3									
			$n_{2 \text{ Eck}}$	8	8	8	8									
			$n_{2 \text{ th}}$	8	8	8	8									

$M \dots$ [Nm]
 $n \dots$ [min^{-1}]
 $J \dots$ [kgcm^2]

$P \dots$ [kW]
 $I \dots$ [A]
 $i \dots$ [-]
 $c \dots$ [-]

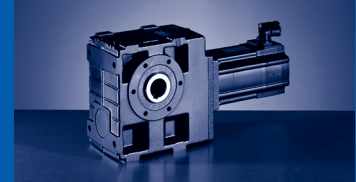

$M_{2GN} \leq 1250 \text{ Nm}$

GSS07-3S				06CC41	06FC41	06IC41	09DC41	09FC38	09HC41	09LC41	12DC20	12DC41	12HC15	12HC30	12HC35
				...500	...500	...500	...500	...500	...500	...500	...500	...500	...500	...500	...500
i	M_{2GN}	J_G	M_1	0.6	1.2	1.5	2.3	3.1	3.8	4.5	5.5	4.3	10	8	7.5
			n_1	4050	4050	4050	4050	3750	4050	4050	1950	4050	1500	3000	3525
			I_{M230}	2.6	2.9	3.2	4.6	5	6.8	8.4	5.2	8.8	7.6	10.5	
			I_{M400}	1.3	1.5	1.6	2.3	2.5	3.4	4.2	2.6	4.5	3.8		5.7
			P_N	0.25	0.51	0.64	1	1.2	1.6	1.9	1.1	1.8	1.6	2.5	2.8
			J_M	0.17	0.25	0.33	1.13	1.53	1.93	2.83	4.12	4.12	7.42	7.42	7.42
553.681	1250	0.18	M_2	235	485	610	943								
			c	4.8	2.4	1.9	1.3								
			$n_{2 \text{ Eck}}$	7	7	7	7								
			$n_{2 \text{ th}}$	7	7	7	7								
634.639	1250	0.11	M_2	272	559	703									
			c	4.2	2.1	1.7									
			$n_{2 \text{ Eck}}$	6	6	6									
			$n_{2 \text{ th}}$	6	6	6									
716.528	1250	0.11	M_2	303	622	782									
			c	3.7	1.9	1.5									
			$n_{2 \text{ Eck}}$	6	6	6									
			$n_{2 \text{ th}}$	6	6	6									
833.556	1250	0.11	M_2	357	728	914									
			c	3	1.5	1.2									
			$n_{2 \text{ Eck}}$	5	5	5									
			$n_{2 \text{ th}}$	5	5	5									
941.111	1250	0.11	M_2	396	807	1013									
			c	2.9	1.4	1.2									
			$n_{2 \text{ Eck}}$	4	4	4									
			$n_{2 \text{ th}}$	4	4	4									
1011.633	1250	0.08	M_2	428	872	1093									
			c	2.6	1.3	1.1									
			$n_{2 \text{ Eck}}$	4	4	4									
			$n_{2 \text{ th}}$	4	4	4									
1142.167	1250	0.08	M_2	475	966										
			c	2.4	1.2										
			$n_{2 \text{ Eck}}$	4	4										
			$n_{2 \text{ th}}$	4	4										
1227.755	1250	0.07	M_2	513	1042										
			c	2.2	1.1										
			$n_{2 \text{ Eck}}$	3	3										
			$n_{2 \text{ th}}$	3	3										
1386.175	1250	0.07	M_2	569	1154										
			c	2	1										
			$n_{2 \text{ Eck}}$	3	3										
			$n_{2 \text{ th}}$	3	3										

M ... [Nm]
n ... [min⁻¹]
J ... [kgcm²]

P ... [kW]
I ... [A]
i [-]
c [-]

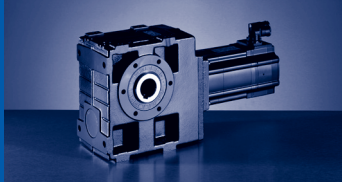

GSS [Nm]

GSS□□-□A (MCA)

$M_{2GN} \leq 180 \text{ Nm}$

GSS04-2A				10IC40	13IC34	13IC41
				...500	...F10	...500
i	M_{2GN}	J_G	M_1			
			n_1	2	6.3	4
			I_{M400}	3950	3410	4050
			P_N	2.4	6	4.4
			J_M	0.8	2.2	1.7
			M_2	2.44	8.34	8.34
5.639	108	1.12	c	10		
			$n_2 \text{ Eck}$	4.4		
			$n_2 \text{ th}$	701		
				700		
5.639	149	1.12	M_2		31	20
			c		1.7	2.2
			$n_2 \text{ Eck}$		605	718
			$n_2 \text{ th}$		605	718
7.733	149	0.65	M_2	13		
			c	5.4		
			$n_2 \text{ Eck}$	511		
			$n_2 \text{ th}$	511		
7.733	158	0.65	M_2		43	27
			c		2	2.7
			$n_2 \text{ Eck}$		441	524
			$n_2 \text{ th}$		441	524
9.042	154	0.81	M_2		50	31
			c		2.1	3.1
			$n_2 \text{ Eck}$		377	448
			$n_2 \text{ th}$		377	448
9.897	161	0.43	M_2	17	55	35
			c	5.7	2.1	2.9
			$n_2 \text{ Eck}$	399	345	409
			$n_2 \text{ th}$	399	345	409
10.827	161	0.37	M_2	18	61	38
			c	5.7	2.1	2.9
			$n_2 \text{ Eck}$	365	315	374
			$n_2 \text{ th}$	365	315	374
12.4	170	0.49	M_2	21	69	43
			c	5.5	1.8	2.7
			$n_2 \text{ Eck}$	319	275	327
			$n_2 \text{ th}$	319	275	327
13.81	163	0.25	M_2	24	78	49
			c	5.8	1.9	2.9
			$n_2 \text{ Eck}$	286	247	293
			$n_2 \text{ th}$	286	247	293
15.869	180	0.33	M_2	27	88	55
			c	4.7	1.6	2.3
			$n_2 \text{ Eck}$	249	215	255
			$n_2 \text{ th}$	249	215	255
17.36	180	0.28	M_2	30	96	61
			c	4.4	1.5	2.2
			$n_2 \text{ Eck}$	228	196	233
			$n_2 \text{ th}$	228	196	233
20.417	153	0.67	M_2	32	103	65
			c	3.2	1.1	1.6
			$n_2 \text{ Eck}$	194	167	198
			$n_2 \text{ th}$	193	167	198
22.143	180	0.2	M_2	38	123	78
			c	3.8	1.2	1.9
			$n_2 \text{ Eck}$	178	154	183
			$n_2 \text{ th}$	178	154	183

$M \dots$ [Nm]
 $n \dots$ [min^{-1}]
 $J \dots$ [kgcm^2]

$P \dots$ [kW]
 $I \dots$ [A]
 i [-]
 c [-]

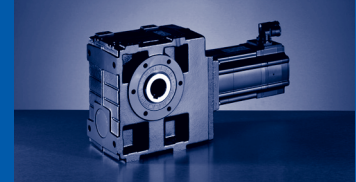

$M_{2GN} \leq 180 \text{ Nm}$

GSS04-2A				10IC40	13IC34	13IC41
				...500	...F10	...500
i	M_{2GN}	J_G	M_1			
			n_1	2	6.3	4
			I_{M400}	3950	3410	4050
			P_N	2.4	6	4.4
			J_M	0.8	2.2	1.7
			M_2	2.44	8.34	8.34
24.8	171	0.42	c	40		81
			$n_2 \text{ Eck}$	2.9		1.5
			$n_2 \text{ th}$	159		163
				159		163
27.125	180	0.14	M_2	47	150	95
			c	3.3	1.1	1.6
			$n_2 \text{ Eck}$	146	126	149
			$n_2 \text{ th}$	146	126	149
31.738	180	0.29	M_2	51		104
			c	2.5		1.3
			$n_2 \text{ Eck}$	125		128
			$n_2 \text{ th}$	124		128
34.1	180	0.1	M_2	59		
			c	2.8		
			$n_2 \text{ Eck}$	116		
			$n_2 \text{ th}$	116		
39.2	180	0.25	M_2	62		126
			c	2.1		1.1
			$n_2 \text{ Eck}$	101		103
			$n_2 \text{ th}$	101		103
43.917	180	0.06	M_2	76		
			c	2.3		
			$n_2 \text{ Eck}$	90		
			$n_2 \text{ th}$	90		
50	180	0.17	M_2	79		
			c	1.8		
			$n_2 \text{ Eck}$	79		
			$n_2 \text{ th}$	79		
54.25	180	0.13	M_2	87		
			c	1.8		
			$n_2 \text{ Eck}$	73		
			$n_2 \text{ th}$	73		
61.25	180	0.13	M_2	96		
			c	1.6		
			$n_2 \text{ Eck}$	65		
			$n_2 \text{ th}$	64		
68.2	180	0.09	M_2	109		
			c	1.5		
			$n_2 \text{ Eck}$	58		
			$n_2 \text{ th}$	58		
77	180	0.09	M_2	120		
			c	1.4		
			$n_2 \text{ Eck}$	51		
			$n_2 \text{ th}$	51		
87.833	180	0.06	M_2	140		
			c	1.3		
			$n_2 \text{ Eck}$	45		
			$n_2 \text{ th}$	45		
99.167	180	0.06	M_2	154		
			c	1.2		
			$n_2 \text{ Eck}$	40		
			$n_2 \text{ th}$	40		

$M \dots$ [Nm]
 $n \dots$ [min^{-1}]
 $J \dots$ [kgcm^2]

$P \dots$ [kW]
 $I \dots$ [A]
 i [-]
 c [-]

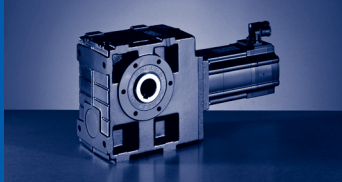

GSS [Nm]

GSS□□-□A (MCA)

$M_{2GN} \leq 360 \text{ Nm}$

GSS05-2A				10IC40	13IC34	13IC41	14LC16	14LC20	14LC35	14LC41
				...500	...F10	...500	...F10	...500	...F10	...500
i	M_{2GN}	J_G	M_1	2	6.3	4	12	6.7	10.8	5.4
			n_1	3950	3410	4050	1635	2000	3455	4100
			I_{M400}	2.4	6	4.4	4.8	3.3	9.1	5.8
			P_N	0.8	2.2	1.7	2.1	1.4	3.9	2.3
			J_M	2.44	8.34	8.34	19.32	19.24	19.24	19.24
5.639	219	2.82	M_2		31	19				
			c		3.8	5.4				
			$n_{2 \text{ Eck}}$		605	718				
			$n_{2 \text{ th}}$		605	718				
5.639	223	2.82	M_2				60	33	54	26
			c				3.2	5.1	2.2	4
			$n_{2 \text{ Eck}}$				290	355	613	727
			$n_{2 \text{ th}}$				290	355	613	637
7.733	267	1.66	M_2		43	27	83	45	75	37
			c		3.4	4.9	2.9	4.7	2	3.6
			$n_{2 \text{ Eck}}$		441	524	211	259	447	530
			$n_{2 \text{ th}}$		441	524	211	259	447	464
9.042	251	2.01	M_2		48	30	94	52	84	41
			c		2.6	3.3	2.5	4.2	1.5	2.5
			$n_{2 \text{ Eck}}$		377	448	181	221	382	454
			$n_{2 \text{ th}}$		377	448	181	221	382	397
9.897	271	1.1	M_2		55	35	107	58	96	47
			c		3.2	4.6	2.5	4.3	1.8	3.4
			$n_{2 \text{ Eck}}$		345	409	165	202	349	414
			$n_{2 \text{ th}}$		345	409	165	202	349	363
10.827	272	0.94	M_2		61	38	117	64	105	52
			c		3.1	4.4	2.3	4	1.8	3.3
			$n_{2 \text{ Eck}}$		315	374	151	185	319	379
			$n_{2 \text{ th}}$		315	374	151	185	319	332
12.4	279	1.24	M_2		67	42	130	72	117	57
			c		2.7	3.8	2	3.4	1.6	2.8
			$n_{2 \text{ Eck}}$		275	327	132	161	279	331
			$n_{2 \text{ th}}$		275	327	132	161	279	290
13.81	275	0.64	M_2		78	49	151	83	135	66
			c		2.9	4.1	1.8	3.2	1.7	3.1
			$n_{2 \text{ Eck}}$		247	293	118	145	250	297
			$n_{2 \text{ th}}$		247	293	118	145	250	260
15.869	301	0.84	M_2		87	54	168	92	150	74
			c		2.5	3.8	1.7	2.9	1.5	2.8
			$n_{2 \text{ Eck}}$		215	255	103	126	218	258
			$n_{2 \text{ th}}$		215	255	103	126	218	226
17.36	311	0.72	M_2		95	60	184	101	165	81
			c		2.4	3.6	1.6	2.7	1.4	2.7
			$n_{2 \text{ Eck}}$		196	233	94	115	199	236
			$n_{2 \text{ th}}$		196	233	94	115	199	207
20.417	253	1.6	M_2		99	62	196	108		85
			c		1.4	2.1	1.2	2		1.5
			$n_{2 \text{ Eck}}$		167	198	80	98		201
			$n_{2 \text{ th}}$		167	198	80	98		176
22.143	337	0.5	M_2		122	77	235	130	211	104
			c		2	3.1	1.3	2.3	1.2	2.3
			$n_{2 \text{ Eck}}$		154	183	74	90	156	185
			$n_{2 \text{ th}}$		154	183	74	90	156	162
24.8	280	1.06	M_2		125	79	245	135		107
			c		1.6	2.2	1.1	1.8		1.6
			$n_{2 \text{ Eck}}$		138	163	66	81		165
			$n_{2 \text{ th}}$		138	163	66	81		145

$M \dots$ [Nm]
 $n \dots$ [min^{-1}]
 $J \dots$ [kgcm^2]

$P \dots$ [kW]
 $I \dots$ [A]
 $i \dots$ [-]
 $c \dots$ [-]

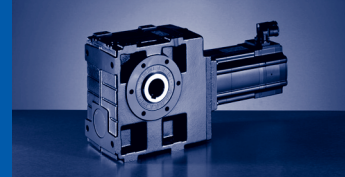

$M_{2GN} \leq 360 \text{ Nm}$

GSS05-2A				10IC40	13IC34	13IC41	14LC16	14LC20	14LC35	14LC41
				...S00	...F10	...S00	...F10	...S00	...F10	...S00
i	M_{2GN}	J_G	M_1	2	6.3	4	12	6.7	10.8	5.4
			n_1	3950	3410	4050	1635	2000	3455	4100
			I_{M400}	2.4	6	4.4	4.8	3.3	9.1	5.8
			P_N	0.8	2.2	1.7	2.1	1.4	3.9	2.3
			J_M	2.44	8.34	8.34	19.32	19.24	19.24	19.24
27.125	360	0.38	M_2	46	150	94	288	160	260	128
			c	5.3	1.8	2.7	1.2	2	1	2
			$n_{2 \text{ Eck}}$	146	126	149	60	74	127	151
			$n_{2 \text{ th}}$	146	126	149	60	74	127	132
31.738	306	0.73	M_2	50	162	102		174		139
			c	4.1	1.3	2		1.5		1.5
			$n_{2 \text{ Eck}}$	125	107	128		63		129
			$n_{2 \text{ th}}$	124	107	128		63		113
35.306	360	0.23	M_2	60	196	124				
			c	4.5	1.5	2.2				
			$n_{2 \text{ Eck}}$	112	97	115				
			$n_{2 \text{ th}}$	112	97	115				
39.2	323	0.61	M_2	61	198	125		211		169
			c	3.5	1.2	1.8		1.3		1.3
			$n_{2 \text{ Eck}}$	101	87	103		51		105
			$n_{2 \text{ th}}$	101	87	103		51		92
43.917	360	0.17	M_2	76	245	154				
			c	3.9	1.3	1.9				
			$n_{2 \text{ Eck}}$	90	78	92				
			$n_{2 \text{ th}}$	90	78	92				
50	353	0.44	M_2	79		160		271		217
			c	3		1.5		1.2		1.1
			$n_{2 \text{ Eck}}$	79		81		40		82
			$n_{2 \text{ th}}$	79		81		40		72
54.25	360	0.34	M_2	87		178		299		241
			c	2.9		1.4		1.1		1.1
			$n_{2 \text{ Eck}}$	73		75		37		76
			$n_{2 \text{ th}}$	73		75		37		66
61.25	360	0.33	M_2	97		197		332		
			c	2.6		1.3		1		
			$n_{2 \text{ Eck}}$	65		66		33		
			$n_{2 \text{ th}}$	64		66		33		
70.611	360	0.21	M_2	114		232				
			c	2.4		1.2				
			$n_{2 \text{ Eck}}$	56		57				
			$n_{2 \text{ th}}$	56		57				
79.722	360	0.21	M_2	127		258				
			c	2.2		1.1				
			$n_{2 \text{ Eck}}$	50		51				
			$n_{2 \text{ th}}$	50		51				
87.833	360	0.15	M_2	143		289				
			c	2.1		1.1				
			$n_{2 \text{ Eck}}$	45		46				
			$n_{2 \text{ th}}$	45		46				
99.167	360	0.15	M_2	159						
			c	2						
			$n_{2 \text{ Eck}}$	40						
			$n_{2 \text{ th}}$	40						
113.667	360	0.1	M_2	186						
			c	1.8						
			$n_{2 \text{ Eck}}$	35						
			$n_{2 \text{ th}}$	35						

M ... [Nm]
n ... [min⁻¹]
J ... [kgcm²]

P ... [kW]
I ... [A]
i [-]
c [-]

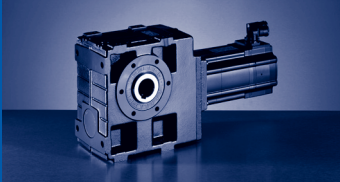

GSS [Nm]

GSS□□-□A (MCA)

$M_{2GN} \leq 360 \text{ Nm}$

GSS05-2A				10IC40	13IC34	13IC41	14LC16	14LC20	14LC35	14LC41
				...S00	...F10	...S00	...F10	...S00	...F10	...S00
i	M_{2GN}	J_G	M_1							
			n_1	2	6.3	4	12	6.7	10.8	5.4
			I_{M400}	3950	3410	4050	1635	2000	3455	4100
			P_N	2.4	6	4.4	4.8	3.3	9.1	5.8
			J_M	0.8	2.2	1.7	2.1	1.4	3.9	2.3
			M_2	2.44	8.34	8.34	19.32	19.24	19.24	19.24
128.333	360	0.09	c	206						
			$n_{2 \text{ Eck}}$	1.7						
			$n_{2 \text{ th}}$	31						
			$n_{2 \text{ th}}$	31						
137.95	360	0.07	M_2	226						
			c	1.6						
			$n_{2 \text{ Eck}}$	29						
			$n_{2 \text{ th}}$	29						
155.75	360	0.07	M_2	251						
			c	1.4						
			$n_{2 \text{ Eck}}$	25						
			$n_{2 \text{ th}}$	25						

$M \dots$ [Nm]
 $n \dots$ [min^{-1}]
 $J \dots$ [kgcm^2]

$P \dots$ [kW]
 $I \dots$ [A]
 i [-]
 c [-]

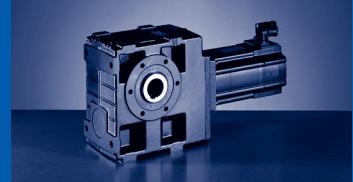

$M_{2GN} \leq 360 \text{ Nm}$

GSS05-3A				10IC40
				...500
i	M_{2GN}	J_G	M_1	
			n_1	2
			I_{M400}	3950
			P_N	2.4
			J_M	0.8
			M_2	2.44
			c	218
125.476	339	0.15	$n_{2 \text{ Eck}}$	1.2
			$n_{2 \text{ th}}$	32
			M_2	31
			c	265
153.708	356	0.12	$n_{2 \text{ Eck}}$	1
			$n_{2 \text{ th}}$	26
			M_2	26
			c	353
222.133	360	0.21	$n_{2 \text{ Eck}}$	1
			$n_{2 \text{ th}}$	18
				18

M ... [Nm]
n ... [min^{-1}]
J ... [kgcm^2]

P ... [kW]
I ... [A]
i [-]
c [-]

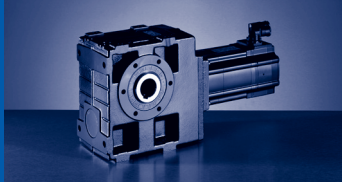

GSS [Nm]

GSS□□-□A (MCA)

$M_{2GN} \leq 720 \text{ Nm}$

GSS06-2A				10IC40	13IC34	13IC41	14LC16	14LC20	14LC35	14LC41	17NC17	17NC23	17NC35	17NC41	
				...S00	...F10	...S00	...F10	...S00	...F10	...S00	...F10	...S00	...F10	...S00	...F10
i	M_{2GN}	J_G	M_1	2	6.3	4	12	6.7	10.8	5.4	21.5	10.8	19	9.5	
			n_1	3950	3410	4050	1635	2000	3455	4100	1680	2300	3480	4110	
			I_{M400}	2.4	6	4.4	4.8	3.3	9.1	5.8	8.5	5.5	15.8	10.2	
			P_N	0.8	2.2	1.7	2.1	1.4	3.9	2.3	3.8	2.6	6.9	4.1	
			J_M	2.44	8.34	8.34	19.32	19.24	19.24	19.24	36.04	36.04	36.04	36.04	
5.833	356	6.97	M_2				61		56	27	113	56	100	49	
			c				4.9		2.6	4.3	2.7	3.9	1.5	2.4	
			n_2 Eck				280		592	703	288	394	597	705	705
			n_2 th				280		592	615	288	394	533	533	533
8	489	4.22	M_2				85		77	38	155	77	137	68	
			c				4.4		2.8	4.9	2.4	3.8	1.6	2.8	
			n_2 Eck				204		432	513	210	288	435	514	
			n_2 th				204		432	449	210	288	389	389	
9.042	417	5.54	M_2				95		86	42	173	86	153	76	
			c				3.8		2.6	4.7	2.1	3.2	1.5	2.7	
			n_2 Eck				181		382	454	186	254	385	455	
			n_2 th				181		382	397	186	254	344	344	
10.238	397	2.81	M_2		57										
			c		4.8										
			n_2 Eck		333										
			n_2 th		333										
10.238	522	2.81	M_2				109		99	48	199	99	177	87	
			c				4.5		2.8	5	2.5	3.5	1.6	2.9	
			n_2 Eck				160		338	401	164	225	340	401	
			n_2 th				160		337	351	164	225	304	304	
11.2	440	2.39	M_2		62										
			c		4.7										
			n_2 Eck		305										
			n_2 th		304										
11.2	524	2.39	M_2				119		109	53	218	108	193	95	
			c				4.2		2.8	5	2.4	3.4	1.6	2.8	
			n_2 Eck				146		309	366	150	205	311	367	
			n_2 th				146		308	321	150	205	278	278	
12.4	523	3.46	M_2				130	71	119	58	237	118	211	104	
			c				3.4	5.5	2.3	4.3	1.9	2.9	1.3	2.4	
			n_2 Eck				132	161	279	331	136	186	281	332	
			n_2 th				132	161	279	290	135	185	251	251	
14.286	513	1.63	M_2		80										
			c		4.4										
			n_2 Eck		239										
			n_2 th		239										
14.286	528	1.63	M_2				154	83	139	68	281	138	248	122	
			c				3.3	6	2.6	4.7	1.9	3.5	1.5	2.7	
			n_2 Eck				115	140	242	287	118	161	244	288	
			n_2 th				114	140	242	251	118	161	218	218	
15.869	597	2.35	M_2		87	54									
			c		3.7	5.4									
			n_2 Eck		215	255									
			n_2 th		215	255									
15.869	605	2.35	M_2				166	91	152	75	303	151	270	134	
			c				3.2	5.2	2.2	4	1.8	2.7	1.2	2.3	
			n_2 Eck				103	126	218	258	106	145	219	259	
			n_2 th				103	126	218	226	106	145	196	196	
17.36	624	2.01	M_2		95	60	182	100	166	82	331	165	296	146	
			c		3.6	5.2	3.1	5	2.1	3.9	1.8	2.7	1.2	2.2	
			n_2 Eck		196	233	94	115	199	236	97	133	201	237	
			n_2 th		196	233	94	115	199	207	97	132	179	179	

$M \dots$ [Nm]
 $n \dots$ [min^{-1}]
 $J \dots$ [kgcm^2]

$P \dots$ [kW]
 $I \dots$ [A]
 i [-]
 c [-]

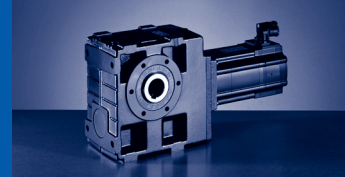

$M_{2GN} \leq 720 \text{ Nm}$

GSS06-2A				10IC40	13IC34	13IC41	14LC16	14LC20	14LC35	14LC41	17NC17	17NC23	17NC35	17NC41
				...S00	...F10	...S00	...F10	...S00	...F10	...S00	...F10	...S00	...F10	...S00
i	M_{2GN}	J_G	M_1	2	6.3	4	12	6.7	10.8	5.4	21.5	10.8	19	9.5
			n_1	3950	3410	4050	1635	2000	3455	4100	1680	2300	3480	4110
			I_{M400}	2.4	6	4.4	4.8	3.3	9.1	5.8	8.5	5.5	15.8	10.2
			P_N	0.8	2.2	1.7	2.1	1.4	3.9	2.3	3.8	2.6	6.9	4.1
			J_M	2.44	8.34	8.34	19.32	19.24	19.24	19.24	36.04	36.04	36.04	36.04
20.417	488	4.17	M_2				201	111	182	89	364	182		160
			c				2.1	3.4	1.4	2.6	1.2	1.8		1.5
			n_2 Eck				80	98	169	201	82	113		201
			n_2 th				80	98	169	176	82	113		152
22.143	673	1.39	M_2		122	76	232	127	212	104	422	211	377	187
			c		3.4	4.9	2.7	4.6	2	3.6	1.5	2.5	1.1	2.1
			n_2 Eck		154	183	74	90	156	185	76	104	157	186
			n_2 th		154	183	74	90	156	162	76	104	141	141
24.8	561	3.06	M_2				246	136	225	111	445	223		197
			c				2	3.3	1.4	2.5	1.1	1.7		1.4
			n_2 Eck				66	81	139	165	68	93		166
			n_2 th				66	81	139	145	68	93		125
27.125	718	1.04	M_2		149	93	285	156	260	128	516	258	462	229
			c		3.2	4.6	2.3	4	1.9	3.4	1.3	2.3	1.1	1.9
			n_2 Eck		126	149	60	74	127	151	62	85	128	152
			n_2 th		126	149	60	74	127	132	62	85	115	115
31.738	609	2.1	M_2		166	104	314	173	287	142	568	285		253
			c		2.2	3.1	1.8	3	1.3	2.3	1	1.6		1.3
			n_2 Eck		107	128	52	63	109	129	53	73		130
			n_2 th		107	128	52	63	109	113	53	72		98
35.306	720	0.66	M_2		195	122	371	204	338	166				
			c		2.9	4.3	1.9	3.3	1.7	3.2				
			n_2 Eck		97	115	46	57	98	116				
			n_2 th		97	115	46	57	98	102				
39.2	637	1.64	M_2		203	127	385	213	351	174		349		309
			c		2	2.9	1.6	2.6	1.2	2.2		1.5		1.2
			n_2 Eck		87	103	42	51	88	105		59		105
			n_2 th		87	103	42	51	88	92		59		79
43.917	720	0.48	M_2		242	152	460	255	420	207				
			c		2.6	3.8	1.6	2.8	1.5	2.9				
			n_2 Eck		78	92	37	46	79	93				
			n_2 th		78	92	37	46	79	82				
50	693	1.16	M_2	79	258	162	488	271	447	221		444		393
			c	5.5	1.9	2.7	1.3	2.2	1.1	2		1.3		1.2
			n_2 Eck	79	68	81	33	40	69	82		46		82
			n_2 th	79	68	81	33	40	69	72		46		62
54.25	720	0.96	M_2		282	177	534	296	488	242		484		429
			c		1.9	2.7	1.3	2.2	1.1	2		1.2		1.1
			n_2 Eck		63	75	30	37	64	76		42		76
			n_2 th		63	75	30	37	64	66		42		57
61.25	720	0.89	M_2		316	199	596	331	547	270		542		480
			c		1.7	2.6	1.2	2	1	1.9		1.1		1.1
			n_2 Eck		56	66	27	33	56	67		38		67
			n_2 th		56	66	27	33	56	59		38		51
70.611	720	0.61	M_2	112	366	230	690	384		313				
			c	4.8	1.6	2.4	1	1.8		1.8				
			n_2 Eck	56	48	57	23	28		58				
			n_2 th	56	48	57	23	28		51				
79.722	720	0.57	M_2	126	410	258		429		351				
			c	4.4	1.5	2.2		1.7		1.6				
			n_2 Eck	50	43	51		25		51				
			n_2 th	50	43	51		25		45				

$M \dots$ [Nm]
 $n \dots$ [min^{-1}]
 $J \dots$ [kgcm^2]

$P \dots$ [kW]
 $I \dots$ [A]
 i [-]
 c [-]

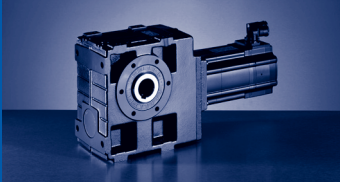

GSS [Nm]

GSS□□-□A (MCA)

$M_{2GN} \leq 720 \text{ Nm}$

GSS06-2A				10IC40	13IC34	13IC41	14LC16	14LC20	14LC35	14LC41	17NC17	17NC23	17NC35	17NC41
				...S00	...F10	...S00	...F10	...S00	...F10	...S00	...F10	...S00	...F10	...S00
i	M_{2GN}	J_G	M_1	2	6.3	4	12	6.7	10.8	5.4	21.5	10.8	19	9.5
			n_1	3950	3410	4050	1635	2000	3455	4100	1680	2300	3480	4110
			I_{M400}	2.4	6	4.4	4.8	3.3	9.1	5.8	8.5	5.5	15.8	10.2
			P_N	0.8	2.2	1.7	2.1	1.4	3.9	2.3	3.8	2.6	6.9	4.1
			J_M	2.44	8.34	8.34	19.32	19.24	19.24	19.24	36.04	36.04	36.04	36.04
87.833	720	0.44	M_2	140	455	286		475		389				
			c	4.2	1.4	2.1		1.5		1.6				
			$n_{2 \text{ Eck}}$	45	39	46		23		47				
			$n_{2 \text{ th}}$	45	39	46		23		41				
99.167	720	0.42	M_2	157	509	321		531		436				
			c	3.8	1.3	1.9		1.4		1.4				
			$n_{2 \text{ Eck}}$	40	34	41		20		41				
			$n_{2 \text{ th}}$	40	34	41		20		36				
113.667	720	0.28	M_2	181	587	370								
			c	3.6	1.2	1.8								
			$n_{2 \text{ Eck}}$	35	30	36								
			$n_{2 \text{ th}}$	35	30	36								
128.333	720	0.26	M_2	203	656	414								
			c	3.2	1.1	1.6								
			$n_{2 \text{ Eck}}$	31	27	32								
			$n_{2 \text{ th}}$	31	27	32								
137.95	720	0.2	M_2	219	709	447								
			c	3.2	1	1.6								
			$n_{2 \text{ Eck}}$	29	25	29								
			$n_{2 \text{ th}}$	29	25	29								
155.75	720	0.19	M_2	245		499								
			c	2.9		1.4								
			$n_{2 \text{ Eck}}$	25		26								
			$n_{2 \text{ th}}$	25		26								
174.375	720	0.13	M_2	276										
			c	2.5										
			$n_{2 \text{ Eck}}$	23										
			$n_{2 \text{ th}}$	23										
196.875	720	0.12	M_2	309										
			c	2.3										
			$n_{2 \text{ Eck}}$	20										
			$n_{2 \text{ th}}$	20										

$M \dots$ [Nm]
 $n \dots$ [min^{-1}]
 $J \dots$ [kgcm^2]

$P \dots$ [kW]
 $I \dots$ [A]
 i [-]
 c [-]

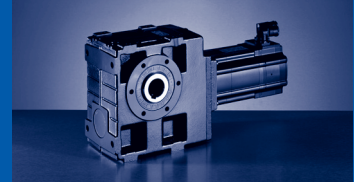

$M_{2GN} \leq 720 \text{ Nm}$

GSS06-3A				10IC40	13IC34
				...S00	...F10
i	M_{2GN}	J_G	M_1		
			n_1	2	6.3
			I_{M400}	3950	3410
			P_N	2.4	6
			J_M	0.8	2.2
			M_2	2.44	8.34
126.531	720	0.31	c	196	623
			$n_{2 \text{ Eck}}$	1.9	1.1
			$n_{2 \text{ th}}$	31	27
			M_2	31	27
142.857	720	0.3	c	218	695
			$n_{2 \text{ Eck}}$	1.9	1
			$n_{2 \text{ th}}$	28	24
			M_2	28	24
155	720	0.27	c	238	
			$n_{2 \text{ Eck}}$	1.7	
			$n_{2 \text{ th}}$	26	
			M_2	25	
175	720	0.26	c	265	
			$n_{2 \text{ Eck}}$	1.7	
			$n_{2 \text{ th}}$	23	
			M_2	23	
194.857	720	0.14	c	297	
			$n_{2 \text{ Eck}}$	1.4	
			$n_{2 \text{ th}}$	20	
			M_2	20	
220	720	0.14	c	331	
			$n_{2 \text{ Eck}}$	1.4	
			$n_{2 \text{ th}}$	18	
			M_2	18	
238.7	720	0.13	c	361	
			$n_{2 \text{ Eck}}$	1.3	
			$n_{2 \text{ th}}$	17	
			M_2	17	
269.5	720	0.12	c	401	
			$n_{2 \text{ Eck}}$	1.3	
			$n_{2 \text{ th}}$	15	
			M_2	15	

M ... [Nm]
n ... [min⁻¹]
J ... [kgcm²]

P ... [kW]
I ... [A]
i [-]
c [-]

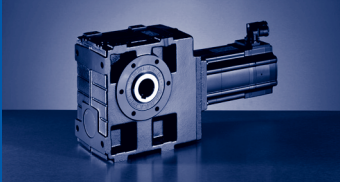

GSS [Nm]

GSS□□-□A (MCA)

$M_{2GN} \leq 1250 \text{ Nm}$

GSS07-2A				10IC40	13IC34	13IC41	14LC16	14LC20	14LC35	14LC41	17NC17	17NC23	
				...S00	...F10	...S00	...F10	...S00	...F10	...S00	...F10	...S00	
i	M_{2GN}	J_G	M_1	2	6.3	4	12	6.7	10.8	5.4	21.5	10.8	
			n_1	3950	3410	4050	1635	2000	3455	4100	1680	2300	
			I_{M400}	2.4	6	4.4	4.8	3.3	9.1	5.8	8.5	5.5	
			P_N	0.8	2.2	1.7	2.1	1.4	3.9	2.3	3.8	2.6	
			J_M	2.44	8.34	8.34	19.32	19.24	19.24	19.24	36.04	36.04	
5.862	539	21.36	M_2								113		
			c								4.1		
			n_2 Eck									287	
			n_2 th									287	
8.125	685	12.75	M_2								157	77	
			c								3.7	5.6	
			n_2 Eck								207	283	
			n_2 th								207	283	
9.086	628	17.44	M_2								173	85	
			c								3.1	5	
			n_2 Eck								185	253	
			n_2 th								185	253	
10	746	9.14	M_2						96				
			c						4.2				
			n_2 Eck						346				
			n_2 th						346				
10	797	9.14	M_2								194	95	
			c								3.5	5.3	
			n_2 Eck								168	230	
			n_2 th								168	230	
11.2	775	7.5	M_2						108				
			c						4.1				
			n_2 Eck						309				
			n_2 th						308				
11.2	866	7.5	M_2								218	107	
			c								3.4	5.1	
			n_2 Eck								150	205	
			n_2 th								150	205	
12.594	799	10.71	M_2								240	119	
			c								2.9	4.3	
			n_2 Eck								133	183	
			n_2 th								133	183	
14.286	832	4.84	M_2				152		139				
			c				5.2		3.8				
			n_2 Eck				115		242				
			n_2 th				114		242				
14.286	973	4.84	M_2								279	137	
			c								3.2	4.8	
			n_2 Eck								118	161	
			n_2 th								118	161	
14.286	1036	4.84	M_2										
			c										
			n_2 Eck										
			n_2 th										
15.5	931	7.79	M_2				161		148		295	146	
			c				4.9		3.3		2.7	4.1	
			n_2 Eck				106		223		108	148	
			n_2 th				105		223		108	148	
17.36	1012	6.42	M_2				180		166	80	331	164	
			c				4.7		3.1	5.8	2.6	4	
			n_2 Eck				94		199	236	97	133	
			n_2 th				94		199	207	97	132	

M ... [Nm]
 n ... [min⁻¹]
 J ... [kgcm²]

P ... [kW]
 I ... [A]
 i [-]
 c [-]

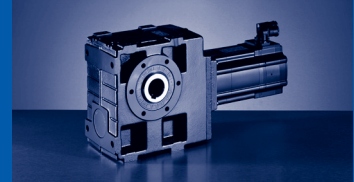

$M_{2GN} \leq 1250 \text{ Nm}$

17NC35	17NC41	19SC17	19SC23	19SC35	19SC42	21XC17	21XC25	21XC42	GSS07-2A			
...F10	...S00	...F10	...S00	...F10	...S00	...F10	...S00	...S00				
19	9.5	36.3	16.3	36	12	61.4	24.6	17	M_1	J_G	M_{2GN}	i
3480	4110	1700	2340	3510	4150	1710	2490	4160	n_1			
15.8	10.2	13.9	8.2	28.7	14	22.5	13.5	19.8	I_{M400}			
6.9	4.1	6.4	4	13.2	5.2	11	6.4	7.4	P_N			
36.04	36.04	72.12	72.12	72.04	72.12	180.04	180.04	180.04	J_M			
100	49	194	85	193	63	332	131	90	M_2			
2.8	5.1	2.4	4.1	1.5	4	1.4	2.7	2.8	c	21.36	539	5.862
594	701	290	399	599	708	292	425	710	$n_{2\text{Eck}}$			
531	531	290	399	418	418	292	343	343	$n_{2\text{th}}$			
140	68	270	119	269	87	461	182	125	M_2			
2.5	4.6	2.2	3.7	1.3	3.7	1.3	2.5	2.6	c	12.75	685	8.125
428	506	209	288	432	511	211	307	512	$n_{2\text{Eck}}$			
383	383	209	288	301	301	210	248	248	$n_{2\text{th}}$			
154	75	296	131	295	96	504	199	137	M_2			
2.4	4.5	1.8	3.3	1.3	3.6	1.1	2.2	2.5	c	17.44	628	9.086
383	452	187	258	386	457	188	274	458	$n_{2\text{Eck}}$			
342	342	187	258	269	269	188	222	222	$n_{2\text{th}}$			
									M_2			
									c	9.14	746	10
									$n_{2\text{Eck}}$			
									$n_{2\text{th}}$			
173	85	333	147	332	108	568	225	155	M_2			
2.4	4.4	2.1	3.5	1.3	3.5	1.2	2.3	2.5	c	9.14	797	10
348	411	170	234	351	415	171	249	416	$n_{2\text{Eck}}$			
311	311	170	234	245	245	171	201	201	$n_{2\text{th}}$			
									M_2			
									c	7.5	775	11.2
									$n_{2\text{Eck}}$			
									$n_{2\text{th}}$			
194	95	373	165	372	121	637	252	174	M_2			
2.3	4.2	2	3.4	1.2	3.4	1.2	2.3	2.4	c	7.5	866	11.2
311	367	152	209	313	371	153	222	371	$n_{2\text{Eck}}$			
278	278	152	209	219	219	153	180	180	$n_{2\text{th}}$			
214	105	410	182	410	134		278	191	M_2			
2.1	3.9	1.7	2.9	1.1	3.1		1.9	2.2	c	10.71	799	12.594
276	326	135	186	279	330		198	330	$n_{2\text{Eck}}$			
247	247	135	186	194	194		160	160	$n_{2\text{th}}$			
									M_2			
									c	4.84	832	14.286
									$n_{2\text{Eck}}$			
									$n_{2\text{th}}$			
248	122								M_2			
2.2	4								c	4.84	973	14.286
244	288								$n_{2\text{Eck}}$			
218	218								$n_{2\text{th}}$			
		477	211	476	155				M_2			
		1.9	3.2	1.1	3.1				c	4.84	1036	14.286
		119	164	246	291				$n_{2\text{Eck}}$			
		119	164	171	171				$n_{2\text{th}}$			
264	130	505	224		165		342	236	M_2			
1.9	3.5	1.6	2.7		2.8		1.8	2	c	7.79	931	15.5
225	265	110	151		268		161	268	$n_{2\text{Eck}}$			
201	201	110	151		158		130	130	$n_{2\text{th}}$			
296	145	565	251		185		383	265	M_2			
1.8	3.3	1.6	2.6		2.6		1.7	1.9	c	6.42	1012	17.36
201	237	98	135		239		143	240	$n_{2\text{Eck}}$			
179	179	98	135		141		116	116	$n_{2\text{th}}$			

M ... [Nm]
n ... [min⁻¹]
J ... [kgcm²]

P ... [kW]
I ... [A]
i [-]
c [-]

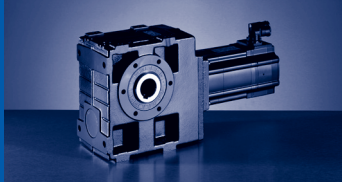

GSS [Nm]

GSS□□-□A (MCA)

$M_{2GN} \leq 1250 \text{ Nm}$

GSS07-2A				10IC40	13IC34	13IC41	14LC16	14LC20	14LC35	14LC41	17NC17	17NC23	
				...S00	...F10	...S00	...F10	...S00	...F10	...S00	...F10	...S00	
i	M_{2GN}	J_G	M_1	2	6.3	4	12	6.7	10.8	5.4	21.5	10.8	
			n_1	3950	3410	4050	1635	2000	3455	4100	1680	2300	
			I_{M400}	2.4	6	4.4	4.8	3.3	9.1	5.8	8.5	5.5	
			P_N	0.8	2.2	1.7	2.1	1.4	3.9	2.3	3.8	2.6	
			J_M	2.44	8.34	8.34	19.32	19.24	19.24	19.24	36.04	36.04	
20.517	764	13.58	M_2								370	183	
			c								1.8	2.9	
			$n_{2 \text{ Eck}}$									82	112
			$n_{2 \text{ th}}$									82	112
22.143	836	4.18	M_2		121								
			c		5								
			$n_{2 \text{ Eck}}$		154								
			$n_{2 \text{ th}}$		154								
22.143	1211	4.18	M_2				230		212	103	421	210	
			c				4.4		2.9	5.4	2.5	3.7	
			$n_{2 \text{ Eck}}$				74		156	185	76	104	
			$n_{2 \text{ th}}$				74		156	162	76	104	
25.188	913	9.59	M_2								458	228	
			c								1.7	2.6	
			$n_{2 \text{ Eck}}$								67	91	
			$n_{2 \text{ th}}$								67	91	
27.125	1250	3.13	M_2				282		260	126	516	257	
			c				4.2		2.8	5.1	2.4	3.5	
			$n_{2 \text{ Eck}}$				60		127	151	62	85	
			$n_{2 \text{ th}}$				60		127	132	62	85	
31	1065	7.05	M_2				309	169	282	138	562	280	
			c				2.9	4.7	2	3.7	1.6	2.5	
			$n_{2 \text{ Eck}}$				53	65	112	132	54	74	
			$n_{2 \text{ th}}$				53	65	111	116	54	74	
35.306	1052	1.96	M_2		193								
			c		4.5								
			$n_{2 \text{ Eck}}$		97								
			$n_{2 \text{ th}}$		97								
35.306	1250	1.96	M_2				369	201	338	165	673	334	
			c				3.3	5.9	2.6	4.8	1.8	3.3	
			$n_{2 \text{ Eck}}$				46	57	98	116	48	65	
			$n_{2 \text{ th}}$				46	57	98	102	48	65	
39.2	1175	5.37	M_2				388	213	355	174	704	352	
			c				2.7	4.3	1.8	3.3	1.5	2.3	
			$n_{2 \text{ Eck}}$				42	51	88	105	43	59	
			$n_{2 \text{ th}}$				42	51	88	92	43	59	
43.271	1090	1.43	M_2		237								
			c		4.2								
			$n_{2 \text{ Eck}}$		79								
			$n_{2 \text{ th}}$		79								
43.271	1250	1.43	M_2				454	248	414	202	824	410	
			c				2.7	4.8	2.5	4.5	1.5	3	
			$n_{2 \text{ Eck}}$				38	46	80	95	39	53	
			$n_{2 \text{ th}}$				38	46	80	83	39	53	
50	1250	3.53	M_2		260	163	495	271	452	223	897	449	
			c		2.9	4.2	2.4	4	1.7	3.1	1.3	2.1	
			$n_{2 \text{ Eck}}$		68	81	33	40	69	82	34	46	
			$n_{2 \text{ th}}$		68	81	33	40	69	72	34	46	
54.25	1250	2.89	M_2				541	297	495	244	981	491	
			c				2.3	3.9	1.7	3.1	1.3	2.1	
			$n_{2 \text{ Eck}}$				30	37	64	76	31	42	
			$n_{2 \text{ th}}$				30	37	64	66	31	42	

$M \dots$ [Nm]
 $n \dots$ [min^{-1}]
 $J \dots$ [kgcm^2]

$P \dots$ [kW]
 $I \dots$ [A]
 $i \dots$ [-]
 $c \dots$ [-]

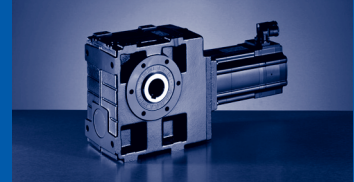

$M_{2GN} \leq 1250 \text{ Nm}$

17NC35	17NC41	19SC17	19SC23	19SC35	19SC42	21XC17	21XC25	21XC42	GSS07-2A			
...F10	...S00	...F10	...S00	...F10	...S00	...F10	...S00	...S00	M_1	J_G	M_{2GN}	i
19	9.5	36.3	16.3	36	12	61.4	24.6	17	n_1			
3480	4110	1700	2340	3510	4150	1710	2490	4160	I_{M400}			
15.8	10.2	13.9	8.2	28.7	14	22.5	13.5	19.8	P_N			
6.9	4.1	6.4	4	13.2	5.2	11	6.4	7.4	J_M			
36.04	36.04	72.12	72.12	72.04	72.12	180.04	180.04	180.04	M_2			
327	161	629	280		205		425	292	c	13.58	764	20.517
1.4	2.6	1.1	1.9		2.1		1.3	1.5	$n_{2\text{ Eck}}$			
170	200	83	114		202		121	203	$n_{2\text{ th}}$			
152	152	83	114		119		98	98	M_2			
									c	4.18	836	22.143
									$n_{2\text{ Eck}}$			
									$n_{2\text{ th}}$			
378	186	720	321		237				M_2			
1.7	3.1	1.5	2.5		2.4				c	4.18	1211	22.143
157	186	77	106		187				$n_{2\text{ Eck}}$			
141	141	77	106		111				$n_{2\text{ th}}$			
406	201	779	347		255		527	363	M_2			
1.2	2.3	1	1.7		1.9		1.1	1.3	c	9.59	913	25.188
138	163	68	93		165		99	165	$n_{2\text{ Eck}}$			
124	124	67	93		97		80	80	$n_{2\text{ th}}$			
463	228	880	393		290				M_2			
1.6	2.9	1.4	2.3		2.3				c	3.13	1250	27.125
128	152	63	86		153				$n_{2\text{ Eck}}$			
115	115	63	86		90				$n_{2\text{ th}}$			
501	248		427		314		649	448	M_2			
1.1	2.1		1.6		1.7		1.1	1.2	c	7.05	1065	31
112	133		76		134		80	134	$n_{2\text{ Eck}}$			
100	100		75		79		65	65	$n_{2\text{ th}}$			
									M_2			
									c	1.96	1052	35.306
									$n_{2\text{ Eck}}$			
									$n_{2\text{ th}}$			
602	297								M_2			
1.5	2.7								c	1.96	1250	35.306
99	116								$n_{2\text{ Eck}}$			
88	88								$n_{2\text{ th}}$			
630	312		536		396		814	563	M_2			
1	1.9		1.5		1.5		1	1.1	c	5.37	1175	39.2
89	105		60		106		64	106	$n_{2\text{ Eck}}$			
79	79		60		62		51	51	$n_{2\text{ th}}$			
									M_2			
									c	1.43	1090	43.271
									$n_{2\text{ Eck}}$			
									$n_{2\text{ th}}$			
737	364								M_2			
1.4	2.6								c	1.43	1250	43.271
80	95								$n_{2\text{ Eck}}$			
72	72								$n_{2\text{ th}}$			
	398		683		505				M_2			
	1.8		1.4		1.4				c	3.53	1250	50
	82		47		83				$n_{2\text{ Eck}}$			
	62		47		49				$n_{2\text{ th}}$			
	435		747		552				M_2			
	1.8		1.4		1.4				c	2.89	1250	54.25
	76		43		77				$n_{2\text{ Eck}}$			
	57		43		45				$n_{2\text{ th}}$			

M ... [Nm]
n ... [min⁻¹]
J ... [kgcm²]

P ... [kW]
I ... [A]
i [-]
c [-]

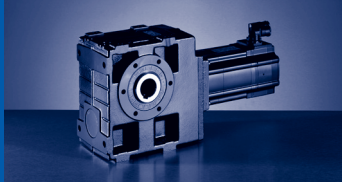

GSS [Nm]

GSS□□-□A (MCA)

$M_{2GN} \leq 1250 \text{ Nm}$

GSS07-2A				10IC40	13IC34	13IC41	14LC16	14LC20	14LC35	14LC41	17NC17	17NC23
				...500	...F10	...S00	...F10	...S00	...F10	...S00	...F10	...S00
i	M_{2GN}	J_G	M_1	2	6.3	4	12	6.7	10.8	5.4	21.5	10.8
			n_1	3950	3410	4050	1635	2000	3455	4100	1680	2300
			I_{M400}	2.4	6	4.4	4.8	3.3	9.1	5.8	8.5	5.5
			P_N	0.8	2.2	1.7	2.1	1.4	3.9	2.3	3.8	2.6
			J_M	2.44	8.34	8.34	19.32	19.24	19.24	19.24	36.04	36.04
61.25	1250	2.7	M_2				606	333	554	273	1097	549
			c				2	3.6	1.6	2.9	1.1	2
			$n_{2 \text{ Eck}}$				27	33	56	67	27	38
			$n_{2 \text{ th}}$				27	33	56	59	27	38
70.611	1250	1.81	M_2		370	232	703	388	643	317		638
			c		2.7	3.9	1.8	3.1	1.6	2.9		1.9
			$n_{2 \text{ Eck}}$		48	57	23	28	49	58		33
			$n_{2 \text{ th}}$		48	57	23	28	49	51		33
79.722	1250	1.7	M_2		414	260	787	435	719	354		714
			c		2.6	3.7	1.6	2.8	1.5	2.7		1.7
			$n_{2 \text{ Eck}}$		43	51	21	25	43	51		29
			$n_{2 \text{ th}}$		43	51	21	25	43	45		29
86.542	1250	1.34	M_2		454	284	858	475	788	388		781
			c		2.5	3.7	1.5	2.6	1.5	2.7		1.6
			$n_{2 \text{ Eck}}$		39	47	19	23	40	47		27
			$n_{2 \text{ th}}$		39	47	19	23	40	41		27
97.708	1250	1.26	M_2		508	318	961	533	881	434		874
			c		2.3	3.5	1.3	2.3	1.3	2.6		1.4
			$n_{2 \text{ Eck}}$		35	42	17	21	35	42		24
			$n_{2 \text{ th}}$		35	41	17	20	35	37		24
113.667	1250	0.83	M_2		596	373	1119	622	1032	509		
			c		2.1	3.2	1.1	2	1.2	2.4		
			$n_{2 \text{ Eck}}$		30	36	14	18	30	36		
			$n_{2 \text{ th}}$		30	36	14	18	30	32		
128.333	1250	0.79	M_2	202	667	418		697	1154	570		
			c	5.8	1.9	2.9		1.8	1.1	2.2		
			$n_{2 \text{ Eck}}$	31	27	32		16	27	32		
			$n_{2 \text{ th}}$	31	27	32		16	27	28		
137.95	1250	0.61	M_2	219	722	453		752	1247	616		
			c	5.4	1.7	2.7		1.7	1	2		
			$n_{2 \text{ Eck}}$	29	25	29		15	25	30		
			$n_{2 \text{ th}}$	29	25	29		15	25	26		
155.75	1250	0.58	M_2	247	808	508		841		691		
			c	4.8	1.5	2.4		1.5		1.8		
			$n_{2 \text{ Eck}}$	25	22	26		13		26		
			$n_{2 \text{ th}}$	25	22	26		13		23		
174.375	1250	0.39	M_2	278	908	571						
			c	4.3	1.4	2.2						
			$n_{2 \text{ Eck}}$	23	20	23						
			$n_{2 \text{ th}}$	23	20	23						
196.875	1250	0.37	M_2	313	1017	640						
			c	3.8	1.2	1.9						
			$n_{2 \text{ Eck}}$	20	17	21						
			$n_{2 \text{ th}}$	20	17	21						

$M \dots [\text{Nm}]$
 $n \dots [\text{min}^{-1}]$
 $J \dots [\text{kgcm}^2]$

$P \dots [\text{kW}]$
 $I \dots [\text{A}]$
 $i [-]$
 $c [-]$

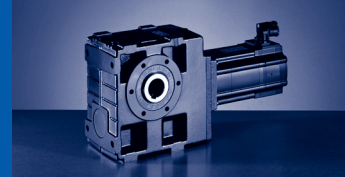

$M_{2GN} \leq 1250 \text{ Nm}$

17NC35	17NC41	19SC17	19SC23	19SC35	19SC42	21XC17	21XC25	21XC42	GSS07-2A			
...F10	...S00	...F10	...S00	...F10	...S00	...F10	...S00	...S00	M_1	J_G	M_{2GN}	i
19	9.5	36.3	16.3	36	12	61.4	24.6	17	n_1			
3480	4110	1700	2340	3510	4150	1710	2490	4160	I_{M400}			
15.8	10.2	13.9	8.2	28.7	14	22.5	13.5	19.8	P_N			
6.9	4.1	6.4	4	13.2	5.2	11	6.4	7.4	J_M			
36.04	36.04	72.12	72.12	72.04	72.12	180.04	180.04	180.04	M_2			
	487		835		617				c	2.7	1250	61.25
	1.7		1.3		1.3				n_2 Eck			
	67		38		68				n_2 th			
	51		38		40				M_2			
	565								c	1.81	1250	70.611
	1.6								n_2 Eck			
	58								n_2 th			
	44								M_2			
	632								c	1.7	1250	79.722
	1.6								n_2 Eck			
	52								n_2 th			
	39								M_2			
	692								c	1.34	1250	86.542
	1.6								n_2 Eck			
	48								n_2 th			
	36								M_2			
	774								c	1.26	1250	97.708
	1.5								n_2 Eck			
	42								n_2 th			
	32								M_2			
									c	0.83	1250	113.667
									n_2 Eck			
									n_2 th			
									M_2			
									c	0.79	1250	128.333
									n_2 Eck			
									n_2 th			
									M_2			
									c	0.61	1250	137.95
									n_2 Eck			
									n_2 th			
									M_2			
									c	0.58	1250	155.75
									n_2 Eck			
									n_2 th			
									M_2			
									c	0.39	1250	174.375
									n_2 Eck			
									n_2 th			
									M_2			
									c	0.37	1250	196.875
									n_2 Eck			
									n_2 th			

M ... [Nm]
n ... [min⁻¹]
J ... [kgcm²]

P ... [kW]
I ... [A]
i [-]
c [-]

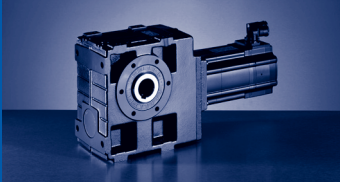

GSS [Nm]

GSS□□-□A (MCA)

$M_{2GN} \leq 1250 \text{ Nm}$

GSS07-3A				10IC40	13IC34	13IC41	14LC16	14LC20	14LC35	14LC41
				...500	...F10	...500	...F10	...500	...F10	...500
i	M_{2GN}	J_G	M_1							
			n_1	2	6.3	4	12	6.7	10.8	5.4
			I_{M400}	3950	3410	4050	1635	2000	3455	4100
			P_N	2.4	6	4.4	4.8	3.3	9.1	5.8
			J_M	0.8	2.2	1.7	2.1	1.4	3.9	2.3
			M_2	2.44	8.34	8.34	19.32	19.24	19.24	19.24
			c	196	632	402	1186	660	1095	545
126.531	1250	0.86	n_2 Eck	3.8	2	1.9	1.1	1.9	1.1	1.4
			n_2 th	31	27	32	13	16	27	32
				31	27	32	13	16	27	28
			M_2	220	708	449		738	1225	610
142.857	1250	0.82	c	3.7	1.8	1.8		1.7	1	1.4
			n_2 Eck	28	24	28		14	24	29
			n_2 th	28	24	28		14	24	25
			M_2	239	772	489		805		664
155	1250	0.74	c	3.7	1.6	1.8		1.5		1.4
			n_2 Eck	26	22	26		13		27
			n_2 th	25	22	26		13		23
			M_2	268	866	548		898		743
175	1250	0.72	c	3.5	1.4	1.7		1.4		1.3
			n_2 Eck	23	20	23		11		23
			n_2 th	23	19	23		11		21
			M_2	310	999	632				
201.746	1250	0.37	c	3.2	1.3	1.6				
			n_2 Eck	20	17	20				
			n_2 th	20	17	20				
			M_2	347	1119	707				
227.778	1250	0.36	c	3	1.1	1.5				
			n_2 Eck	17	15	18				
			n_2 th	17	15	18				
			M_2	378	1218	770				
247.139	1250	0.33	c	2.8	1	1.4				
			n_2 Eck	16	14	16				
			n_2 th	16	14	16				
			M_2	422		859				
279.028	1250	0.32	c	2.7		1.3				
			n_2 Eck	14		15				
			n_2 th	14		15				
			M_2	493						
321.673	1250	0.28	c	1.9						
			n_2 Eck	12						
			n_2 th	12						
			M_2	547						
363.179	1250	0.28	c	1.9						
			n_2 Eck	11						
			n_2 th	11						
			M_2	601						
394.245	1250	0.26	c	1.7						
			n_2 Eck	10						
			n_2 th	10						
			M_2	665						
445.116	1250	0.26	c	1.7						
			n_2 Eck	9						
			n_2 th	9						
			M_2	735						
490.403	1250	0.18	c	1.5						
			n_2 Eck	8						
			n_2 th	8						

M ... [Nm]
 n ... [min⁻¹]
 J ... [kgcm²]

P ... [kW]
 I ... [A]
 i [-]
 c [-]

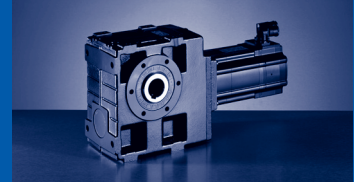

$M_{2GN} \leq 1250 \text{ Nm}$

GSS07-3A				10IC40	13IC34	13IC41	14LC16	14LC20	14LC35	14LC41
				...S00	...F10	...S00	...F10	...S00	...F10	...S00
i	M_{2GN}	J_G	M_1							
			n_1	2	6.3	4	12	6.7	10.8	5.4
			I_{M400}	3950	3410	4050	1635	2000	3455	4100
			P_N	2.4	6	4.4	4.8	3.3	9.1	5.8
			J_M	0.8	2.2	1.7	2.1	1.4	3.9	2.3
			M_2	2.44	8.34	8.34	19.32	19.24	19.24	19.24
553.681	1250	0.18	c	818						
			$n_{2 \text{ Eck}}$	1.4						
			$n_{2 \text{ th}}$	7						
			$n_{2 \text{ th}}$	7						
634.639	1250	0.11	M_2	943						
			c	1.3						
			$n_{2 \text{ Eck}}$	6						
			$n_{2 \text{ th}}$	6						
716.528	1250	0.11	M_2	1048						
			c	1.1						
			$n_{2 \text{ Eck}}$	6						
			$n_{2 \text{ th}}$	6						

M ... [Nm]
n ... [min⁻¹]
J ... [kgcm²]

P ... [kW]
I ... [A]
i [-]
c [-]

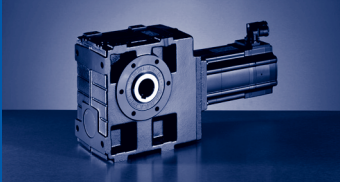

GSS [mm]

GSS□□-2S (MCS)

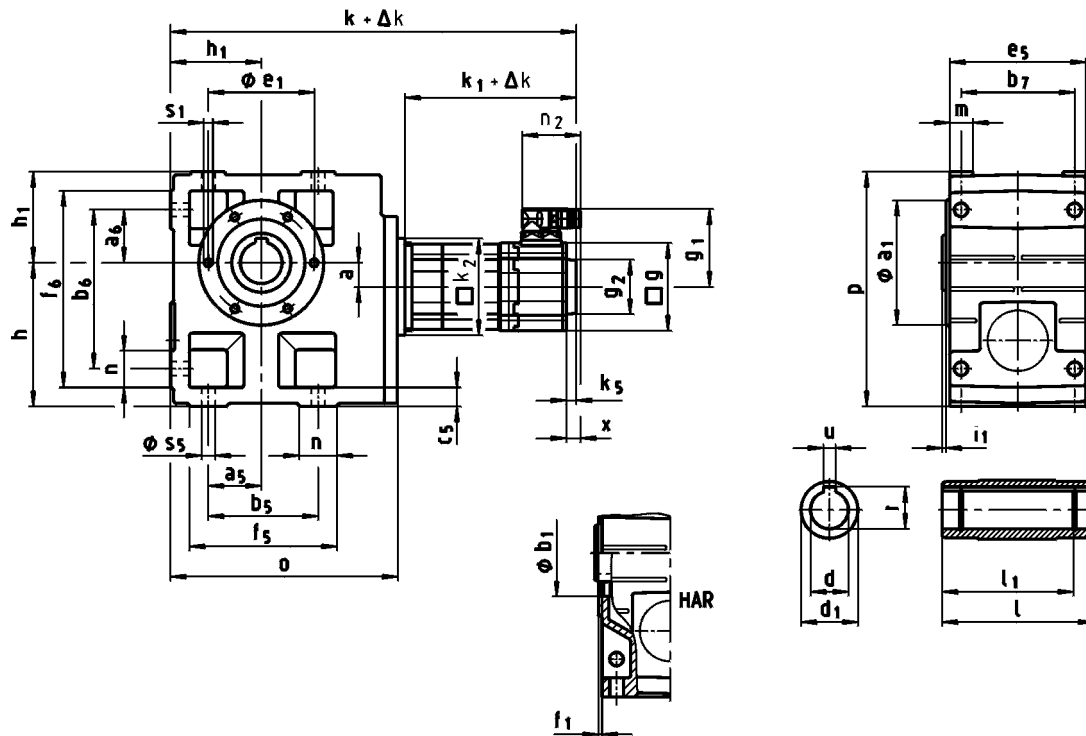

GSS□□-2S H□R ... RSO

		06C C41	06F C41	06I C41	09D C41	09F C38	09H C41	09L C41	12D C20	12D C41	12H C15	12H C30	12H C35	12L C20	12L C41	
GSS04...	k	325	355	385	378	398	418	458								
GSS05...	k	347	377	407	399	419	439	479	416			456			496	
GSS06...	k	387	417	447	439	459	479	519	456			496			536	
GSS07...	k				482	502	522	562	499			539			579	
...RSO B0 ¹⁾	Δk	0														
...RSO P□ ¹⁾	Δk	19				20										
	k_1	132	162	192	183	203	223	263	188			228			268	
	k_2	66			91							118	145 ²⁾			
	g	62				89						116				
...RSO	k_5	0				13						14				
	g_2	□ 62			Ø 67						Ø 72					
	g_1	76				90						105				
	n_2	64								78						
	x					21						18				

¹⁾ → 801 - SRS / SRM / ECN / EQN / EQI / C20

²⁾ GSS05: 12DC20 ... 12LC41

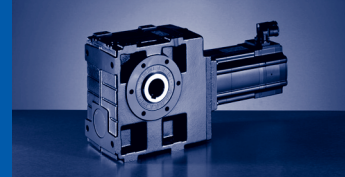

GSS□□-2S H□R ... RSO

		14D C15	14D C36	14H C15	14H C32	14L C15	14L C32	14P C14	14P C32	19F C14	19F C30	19J C14	19J C30	19P C14	19P C30				
GSS06...	k	472		512		552		592											
GSS07...	k	515		555		595		635		554		594		654					
...RSO B0 ¹⁾	Δ k	0																	
...RSO P□ ¹⁾	Δ k	28						34			44								
	k ₁	201		241		281		321		220		260		320					
	k ₂	145						195											
	g	143						192											
...RSO	k ₅	24						15											
	g ₂	Ø 78																	
	g ₁	116				147		116		147		141		172		141		172	
	n ₂	78				94		78		94		78		94		78		94	
	x	16				38		16		38		16		36		16		36	

¹⁾ →  801 - SRS / SRM / ECN / EQN / EQI / C20

GSS□□-2S H□R

	o	p	h	h ₁	a	a ₅	a ₆	b ₅	b ₆	b ₇	c ₅	e ₅	f ₅	f ₆	m	n	s ₅
GSS04...	181	171	100	71	20	45	45	90	119	85	14	100	112	141	20	22	9
GSS05...	212	205	125	80	23	47.5	47.5	95	140	105	17	127	124	169	21	29	11
GSS06...	255	250	150	100	26	60	60	120	170	120	20	145	156	206	23	36	14
GSS07...	305	310	190	120	33	70	70	140	210	150	25	180	185	255	28	45	18

	d	l	d ₁	l ₁	u	t	a ₁	b ₁	e ₁	f ₁	i ₁	s ₁
	H7				JS9	+0,2		H7				6x60°
GSS04...	25	115	45	100	8	28.3	105	75	90	3	2.5	M6x12
	30					33.3						
GSS05...	35	140	50	124	10	38.3	118	80	100	4	4	M8x15
	40					43.3						
GSS06...	45	160	65	140	14	48.8	140	100	120	5	5	M10x16
	50					53.8						
GSS07...	55	200	75	175	16	59.3	165	115	140	5	5	M12x18

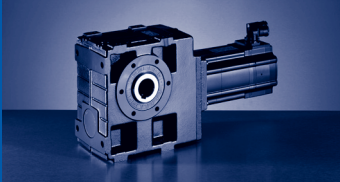

GSS [mm]

GSS□□-2S (MCS)

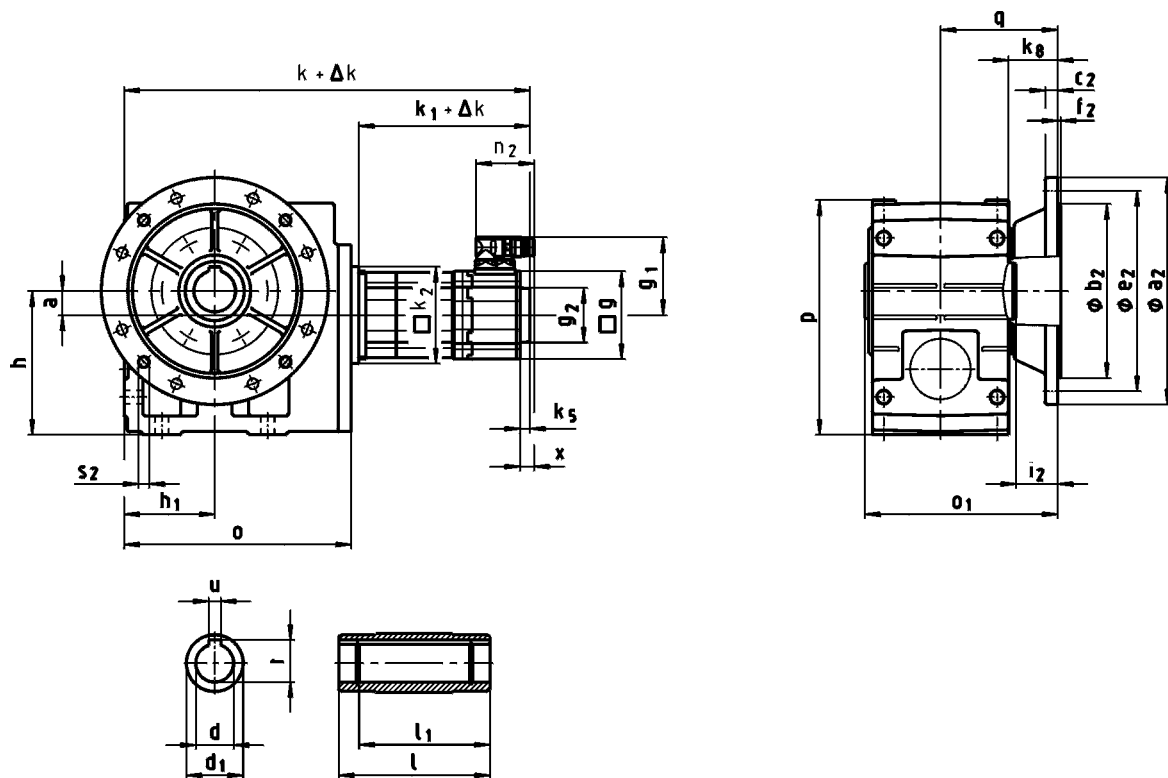

GSS□□-2S HAK ... RSO

		06C C41	06F C41	06I C41	09D C41	09F C38	09H C41	09L C41	12D C20	12D C41	12H C15	12H C30	12H C35	12L C20	12L C41
GSS04...	k	325	355	385	378	398	418	458							
GSS05...	k	347	377	407	399	419	439	479	416		456			496	
GSS06...	k	387	417	447	439	459	479	519	456		496			536	
GSS07...	k				482	502	522	562	499		539			579	
...RSO B0 ¹⁾	Δk	0													
...RSO P□ ¹⁾	Δk	19				20									
	k_1	132	162	192	183	203	223	263	188		228			268	
	k_2	66			91				118				145 ²⁾		
	g	62			89				116						
...RSO	k_5	0			13				14						
	g_2	□ 62			Ø 67				Ø 72						
	g_1	76			90				105						
	n_2	64			78										
	x	21							18						

¹⁾ → 801 - SRS / SRM / ECN/ EQN/ EQI / C20

²⁾ GSS05: 12DC20 ... 12LC41

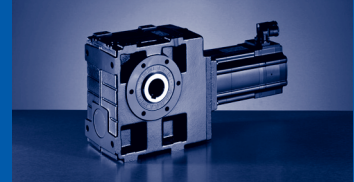

GSS□□-2S HAK ... RSO

		14D C15	14D C36	14H C15	14H C32	14L C15	14L C32	14P C14	14P C32	19F C14	19F C30	19J C14	19J C30	19P C14	19P C30				
GSS06...	k	472		512		552		592											
GSS07...	k	515		555		595		635		554		594		654					
...RSO B0 ¹⁾	Δ k	0																	
...RSO P□ ¹⁾	Δ k	28						34			44								
	k ₁	201		241		281		321		220		260		320					
	k ₂	145						195											
	g	143						192											
...RSO	k ₅	24						15											
	g ₂	Ø 78																	
	g ₁	116				147		116		147		141		172		141		172	
	n ₂	78				94		78		94		78		94		78		94	
	x	16				38		16		38		16		36		16		36	

¹⁾ → 801 - SRS / SRM / ECN / EQN / EQI / C20

GSS□□-2S HAK

	o	o ₁	p	h	h ₁	a	q	k ₈
GSS04...	181	149	171	100	71	20	91	41
GSS05...	212	174	205	125	80	23	103.5	40
GSS06...	255	203 ²⁾ 202 ³⁾	250	150	100	26	122.5 ²⁾ 121.5 ³⁾	50 ²⁾ 49 ³⁾
GSS07...	305	256	310	190	120	33	155.5	66

²⁾ a₂ = 200

³⁾ a₂ = 250

	d	l	d ₁	l ₁	u	t	a ₂	b ₂	c ₂	e ₂	f ₂	i ₂	s ₂
	H7				JS9	+0,2		j7					
GSS04...	25	115	45	100	8	28.3	160	110	10	130	3.5	33.5	4 x 9
	30					33.3							
GSS05...	35	140	50	124	10	38.3	200	130	12	165	3.5	33.5	4 x 11
	40					43.3							
GSS06...	45	160	65	140	14	48.8	250	180	15	215	4	33.5	4 x 14
	50					53.8							
GSS07...	55	200	75	175	16	59.3	300	230	17	265	4	33.5	4 x 14

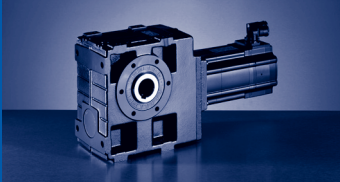

GSS [mm]

GSS□□-2S (MCS)

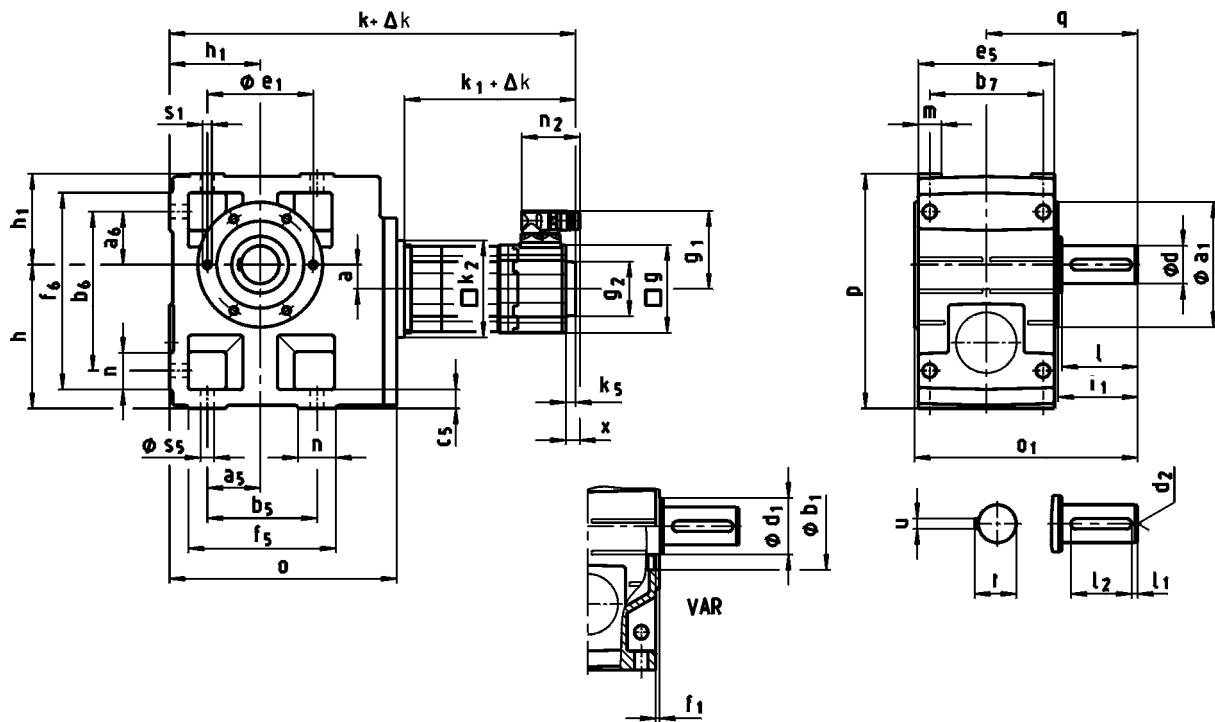

GSS□□-2S V□R ... RSO

		06C C41	06F C41	06I C41	09D C41	09F C38	09H C41	09L C41	12D C20	12D C41	12H C15	12H C30	12H C35	12L C20	12L C41	
GSS04...	k	325	355	385	378	398	418	458								
GSS05...	k	347	377	407	399	419	439	479	416		456			496		
GSS06...	k	387	417	447	439	459	479	519	456		496			536		
GSS07...	k				482	502	522	562	499		539			579		
...RSO B0 ¹⁾	Δk	0														
...RSO P□ ¹⁾	Δk	19				20										
...RSO	k_1	132	162	192	183	203	223	263	188		228			268		
	k_2	66			91				118				145 ²⁾			
	g	62			89				116							
	k_5	0			13				14							
	g_2	□ 62			Ø 67				Ø 72							
	g_1	76			90				105							
	n_2	64			78											
	x	21							18							

¹⁾ → 801 - SRS / SRM / ECN / EQN / EQJ / C20

²⁾ GSS05: 12DC20 ... 12LC41

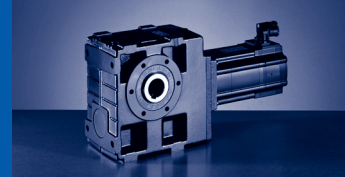

GSS□□-2S V□R ... RSO

		14D C15	14D C36	14H C15	14H C32	14L C15	14L C32	14P C14	14P C32	19F C14	19F C30	19J C14	19J C30	19P C14	19P C30				
GSS06...	k	472		512		552		592											
GSS07...	k	515		555		595		635		554		594		654					
...RSO B0 ¹⁾	Δ k	0																	
...RSO P□ ¹⁾	Δ k	28									34		44						
	k ₁	201		241		281		321		220		260		320					
	k ₂	145						195											
	g	143						192											
...RSO	k ₅	24						15											
	g ₂	Ø 78																	
	g ₁	116				147		116		147		141		172		141		172	
	n ₂	78				94		78		94		78		94		78		94	
	x	16				38		16		38		16		36		16		36	

¹⁾ →  801 - SRS / SRM / ECN / EQN / EQI / C20

GSS□□-2S V□R

	o	o ₁	p	h	h ₁	a	q	a ₅	a ₆	b ₅	b ₆	b ₇	c ₅	e ₅	f ₅	f ₆	m	n	s ₅
GSS04...	181	163	171	100	71	20	107.5	45	45	90	119	85	14	100	112	141	20	22	9
GSS05...	212	197	205	125	80	23	130	47.5	47.5	95	140	105	17	127	124	169	21	29	11
GSS06...	255	236	250	150	100	26	160	60	60	120	170	120	20	145	156	206	23	36	14
GSS07...	305	296	310	190	120	33	200	70	70	140	210	150	25	180	185	255	28	45	18

	d	l	d ₁	l ₁	l ₂	d ₂	u	t	a ₁	b ₁	e ₁	f ₁	i ₁	s ₁
										H7				6x60°
GSS04...	25	50	45	4	40	M10	8	28	105	75	90	3	52.5	M6x12
GSS05...	30	60	50	6	45			33	118	80	100	4	64	M8x15
GSS06...	40	80	65	7	63	M16	14	43	140	100	120		85	M10x16
GSS07...	50	100	75	8	80			53.5	165	115	140	5	105	M12x18

d ≤ 50 mm: k6; d > 50 mm: m6

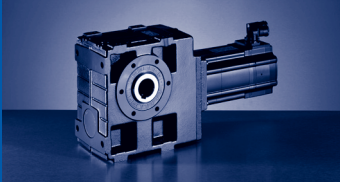

GSS [mm]

GSS□□-2S (MCS)

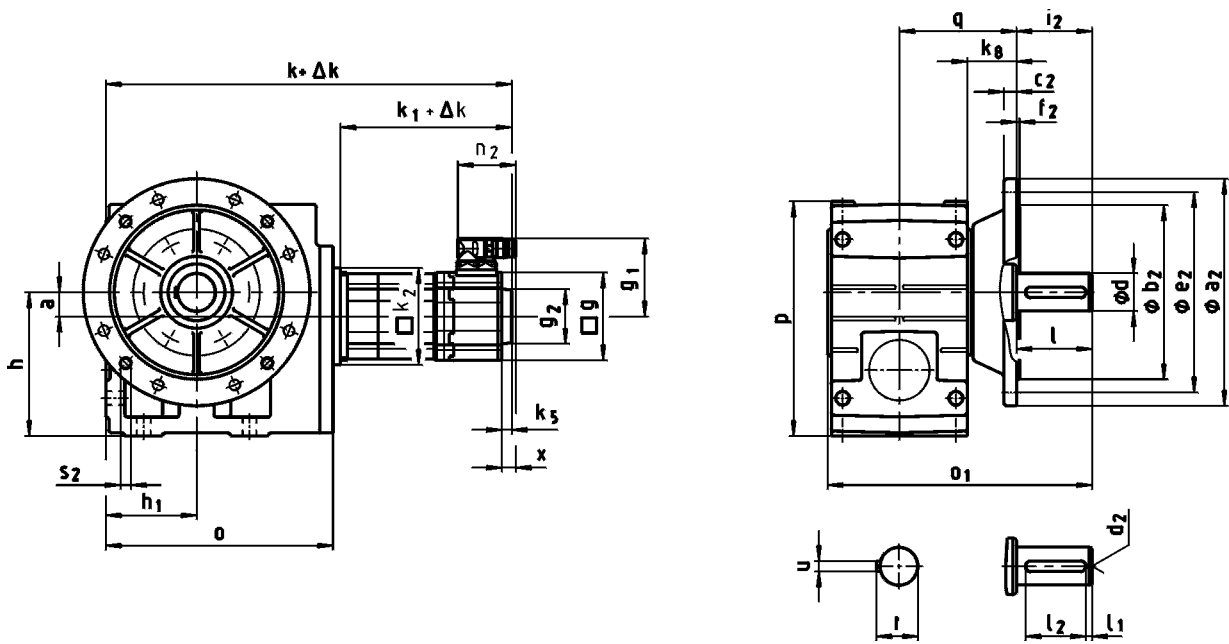

GSS□□-2S VAK ... RSO

		06C C41	06F C41	06I C41	09D C41	09F C38	09H C41	09L C41	12D C20	12D C41	12H C15	12H C30	12H C35	12L C20	12L C41
GSS04...	k	325	355	385	378	398	418	458							
GSS05...	k	347	377	407	399	419	439	479	416			456			496
GSS06...	k	387	417	447	439	459	479	519	456			496			536
GSS07...	k				482	502	522	562	499			539			579
...RSO B0 ¹⁾	Δk	0													
...RSO P□ ¹⁾	Δk	19			20										
	k_1	132	162	192	183	203	223	263	188		228			268	
	k_2	66			91				118				145 ²⁾		
	g	62			89				116						
...RSO	k_5	0			13				14						
	g_2	□ 62			Ø 67				Ø 72						
	g_1	76			90				105						
	n_2	64							78						
	x				21								18		

¹⁾ → 801 - SRS / SRM / ECN / EQN / EQI / C20

²⁾ GSS05: 12DC20 ... 12LC41

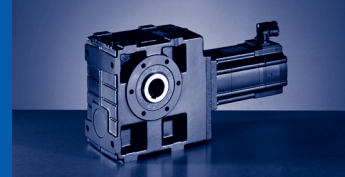

GSS□□-2S VAK ... RSO

		14D C15	14D C36	14H C15	14H C32	14L C15	14L C32	14P C14	14P C32	19F C14	19F C30	19J C14	19J C30	19P C14	19P C30	
GSS06...	k	472		512		552		592								
GSS07...	k	515		555		595		635		554		594		654		
...RSO B0 ¹⁾	Δ k	0														
...RSO P□ ¹⁾	Δ k	28						34			44					
	k ₁	201		241		281		321		220		260		320		
	k ₂	145						195								
	g	143						192								
...RSO	k ₅	24						15								
	g ₂	Ø 78														
	g ₁	116				147	116	147	141	172	141	172	141	172	141	172
	n ₂	78				94	78	94	78	94	78	94	78	94	78	94
	x	16				38	16	38	16	36	16	36	16	36	16	36

¹⁾ → 801 - SRS / SRM / ECN / EQN / EQI / C20

GSS□□-2S VAK

	o	o ₁	p	h	h ₁	a	q	k ₈
GSS04...	181	196	171	100	71	20	91	41
GSS05...	212	230	205	125	80	23	103.5	40
GSS06...	255	277	250	150	100	26	121.5	49
GSS07...	305	351	310	190	120	33	155.5	66

	d	l	l ₁	l ₂	d ₂	u	t	a ₂	b ₂	c ₂	e ₂	f ₂	i ₂	s ₂
									j7					
GSS04...	25	50	4	40	M10	8	28	160	110	10	130	3.5	50	4 x 9
GSS05...	30	60	6	45			33	200	130	12	165		60	4 x 11
GSS06...	40	80	7	63	M16	14	43	250	180	15	215	4	80	4 x 14
GSS07...	50	100	8	80			53.5						300	

d ≤ 50 mm: k6; d > 50 mm: m6

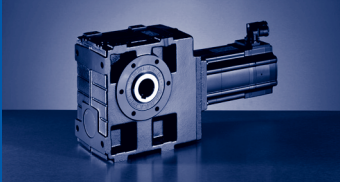

GSS [mm]

GSS□□-3S (MCS)

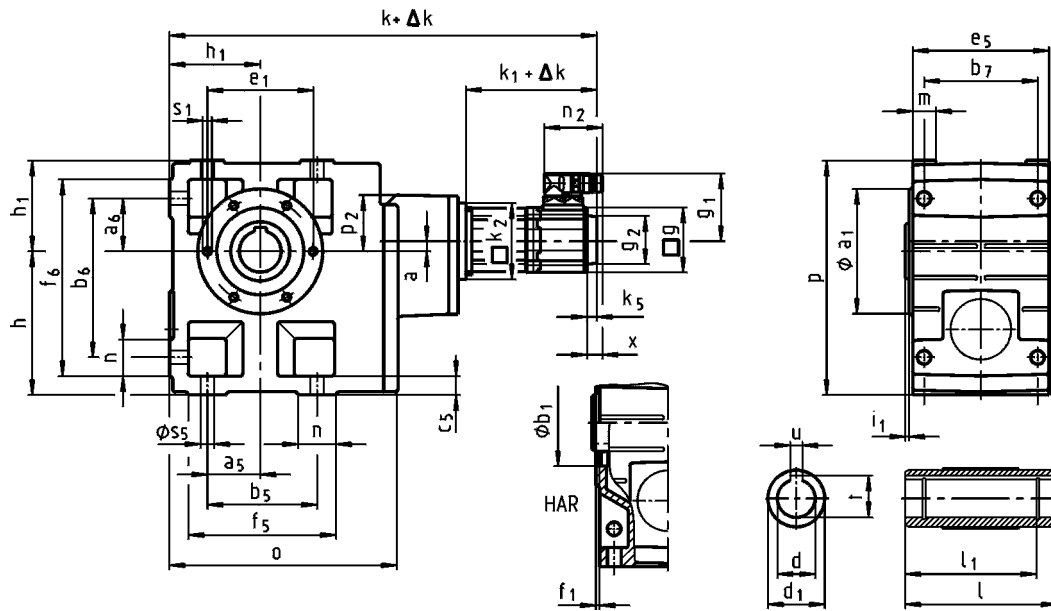

GSS□□-3S H□R ... RSO

		06C C41	06F C41	06I C41	09D C41	09F C38	09H C41	09L C41	12D C20	12D C41	12H C15	12H C30	12H C35	12L C20	12L C41
GSS05...	k	423	453	483	476	496	516	556							
GSS06...	k	480	510	540	533	553	573	613							
GSS07...	k	534	564	594	587	607	627	667	604		644			684	
...RSO B0 ¹⁾	Δk	0													
...RSO P□ ¹⁾	Δk	19			20										
	k_1	132	162	192	183	203	223	263	188		228		268		
	k_2	66			91				118				145 ²⁾		
	g	62			89				116						
...RSO	k_5	0			13				14						
	g_2	□ 62			Ø 67				Ø 72						
	g_1	76			90				105						
	n_2	64							78						
	x				21								18		

¹⁾ → 801 - SRS / SRM / ECN / EQN / EQI / C20

²⁾ GSS07: 12DC20 ... 12LC41

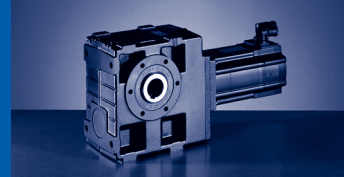

GSS□□-3S H□R

	o	p	p ₂	h	h ₁	a	a ₅	a ₆	b ₅	b ₆	b ₇	c ₅	e ₅	f ₅	f ₆	m	n	s ₅
GSS05...	209	205	65	125	80	13	47.5	47.5	95	140	105	17	127	124	169	21	29	11
GSS06...	252	250	63	150	100	10	60	60	120	170	120	20	145	156	206	23	36	14
GSS07...	299	310	73	190	120	12	70	70	140	210	150	25	180	185	255	28	45	18

	d	l	d ₁	l ₁	u	t	a ₁	b ₁	e ₁	f ₁	i ₁	s ₁
	H7				JS9	+0,2		H7				6x60°
GSS05...	30	140	50	124	8	33.3	118	80	100	4	4	M8x15
	35				10	38.3						
GSS06...	40	160	65	140	12	43.3	140	100	120		5	M10x16
	45				14	48.8						
GSS07...	50	200	75	175	14	53.8	165	115	140	5	M12x18	
	55				16	59.3						

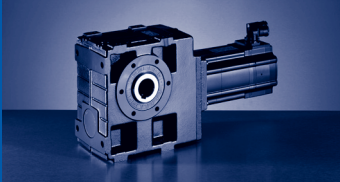

GSS [mm]

GSS□□-3S (MCS)

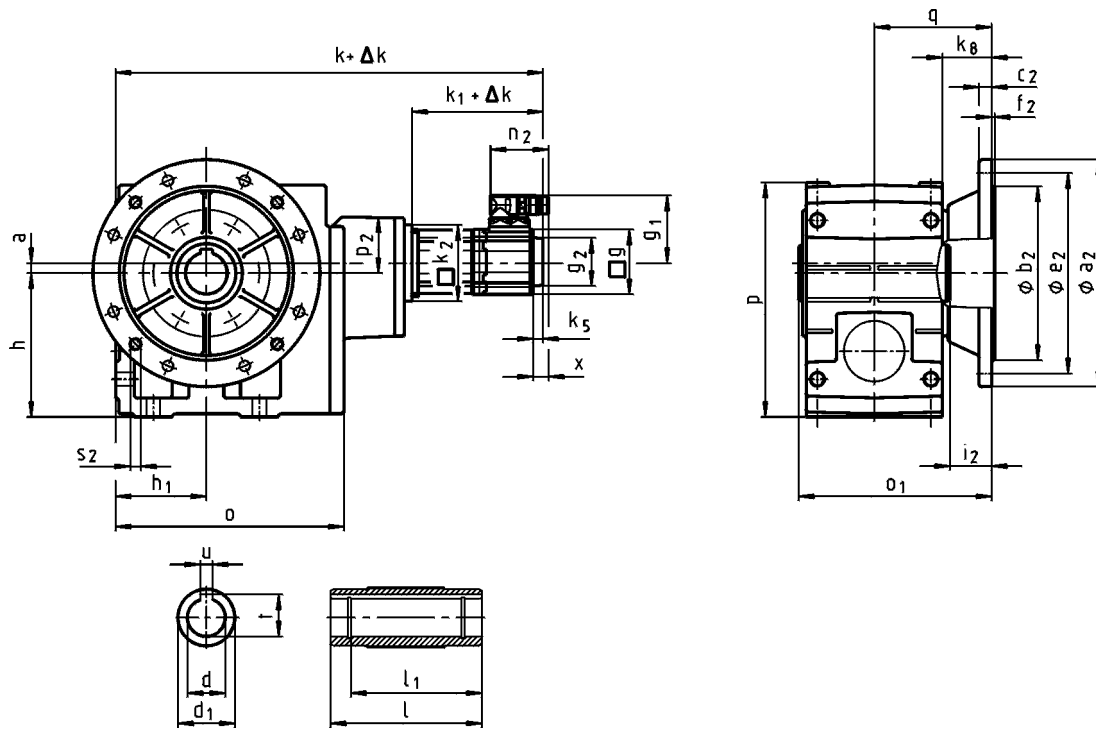

GSS□□-3S HAK ... RSO

		06C C41	06F C41	06I C41	09D C41	09F C38	09H C41	09L C41	12D C20	12D C41	12H C15	12H C30	12H C35	12L C20	12L C41
GSS05...	k	423	453	483	476	496	516	556							
GSS06...	k	480	510	540	533	553	573	613							
GSS07...	k	534	564	594	587	607	627	667	604		644			684	
...RSO B0 ¹⁾	Δk	0													
...RSO P□ ¹⁾	Δk	19			20										
	k_1	132	162	192	183	203	223	263	188		228			268	
	k_2	66			91							118		145 ²⁾	
...RSO	g	62			89							116			
	k_5	0			13							14			
	g_2	□ 62			Ø 67							Ø 72			
	g_1	76			90							105			
	n_2	64								78					
	x				21							18			

¹⁾ → 801 - SRS / SRM / ECN / EQN / EQI / C20

²⁾ GSS07: 12DC20 ... 12LC41

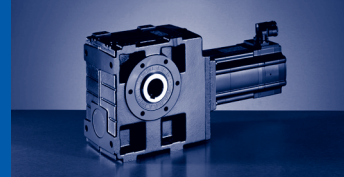

GSS□□-3S HAK

	o	o ₁	p	p ₂	h	h ₁	a	q	k ₈
GSS05...	209	174	205	65	125	80	13	103.5	40
GSS06...	252	203 ¹⁾ 202 ²⁾	250	63	150	100	10	122.5 ¹⁾ 121.5 ²⁾	50 ¹⁾ 49 ²⁾
GSS07...	299	256	310	73	190	120	12	155.5	66

¹⁾ a₂ = 200

²⁾ a₂ = 250

	d	l	d ₁	l ₁	u	t	a ₂	b ₂	c ₂	e ₂	f ₂	i ₂	s ₂
	H7				JS9	+0,2		j7					
GSS05...	30	140	50	124	8	33.3	200	130	12	165	3.5	33.5	4 x 11
	35				10	38.3							
GSS06...	40	160	65	140	12	43.3	250	180	15	215	4	42.5	4 x 14
	45				14	48.8							
GSS07...	50	200	75	175		53.8	300	230	17	265	4	55.5	4 x 14
	55				16	59.3							

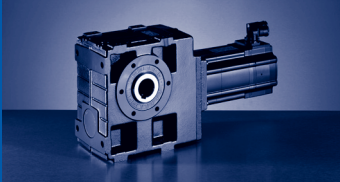

GSS [mm]

GSS□□-3S (MCS)

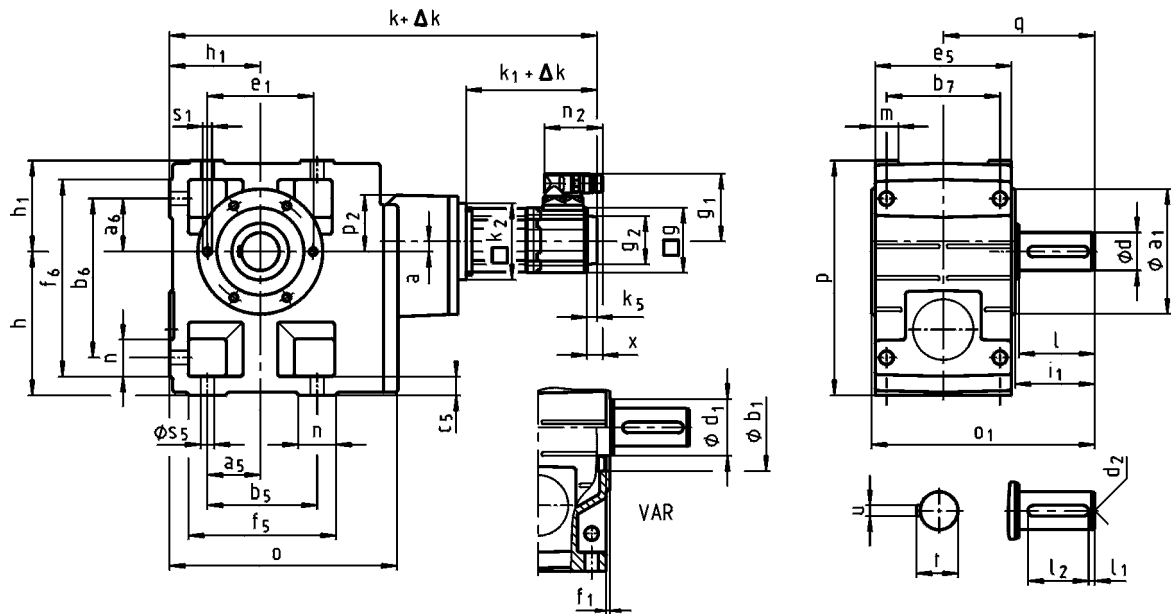

GSS□□-3S V□R ... RSO

		06C C41	06F C41	06I C41	09D C41	09F C38	09H C41	09L C41	12D C20	12D C41	12H C15	12H C30	12H C35	12L C20	12L C41	
GSS05...	k	423	453	483	476	496	516	556								
GSS06...	k	480	510	540	533	553	573	613								
GSS07...	k	534	564	594	587	607	627	667	604		644			684		
...RSO B0 ¹⁾	Δk	0														
...RSO P□ ¹⁾	Δk	19			20											
	k_1	132	162	192	183	203	223	263	188			228			268	
	k_2	66			91							118				145 ²⁾
	g	62			89							116				
...RSO	k_5	0			13							14				
	g_2	□ 62			Ø 67							Ø 72				
	g_1	76			90							105				
	n_2	64								78						
	x				21										18	

¹⁾ → 801 - SRS / SRM / ECN / EQN / EQI / C20

²⁾ GSS07: 12DC20 ... 12LC41

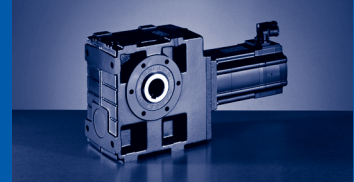

GSS□□-3S V□R

	o	o ₁	p	p ₂	h	h ₁	a	q	a ₅	a ₆	b ₅	b ₆	b ₇	c ₅	e ₅	f ₅	f ₆	m	n	s ₅
GSS05...	209	197	205	65	125	80	13	130	47.5	47.5	95	140	105	17	127	124	169	21	29	11
GSS06...	252	236	250	63	150	100	10	160	60	60	120	170	120	20	145	156	206	23	36	14
GSS07...	299	296	310	73	190	120	12	200	70	70	140	210	150	25	180	185	255	28	45	18

	d	l	d ₁	l ₁	l ₂	d ₂	u	t	a ₁	b ₁	e ₁	f ₁	i ₁	s ₁
										H7				6x60°
GSS05...	30	60	50	6	45	M10	8	33	118	80	100	4	64	M8x15
GSS06...	40	80	65	7	63	M16	12	43	140	100	120		85	M10x16
GSS07...	50	100	75	8	80		14	53.5	165	115	140	5	105	M12x18

d ≤ 50 mm: k6; d > 50 mm: m6

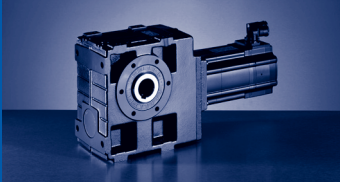

GSS [mm]

GSS□□-3S (MCS)

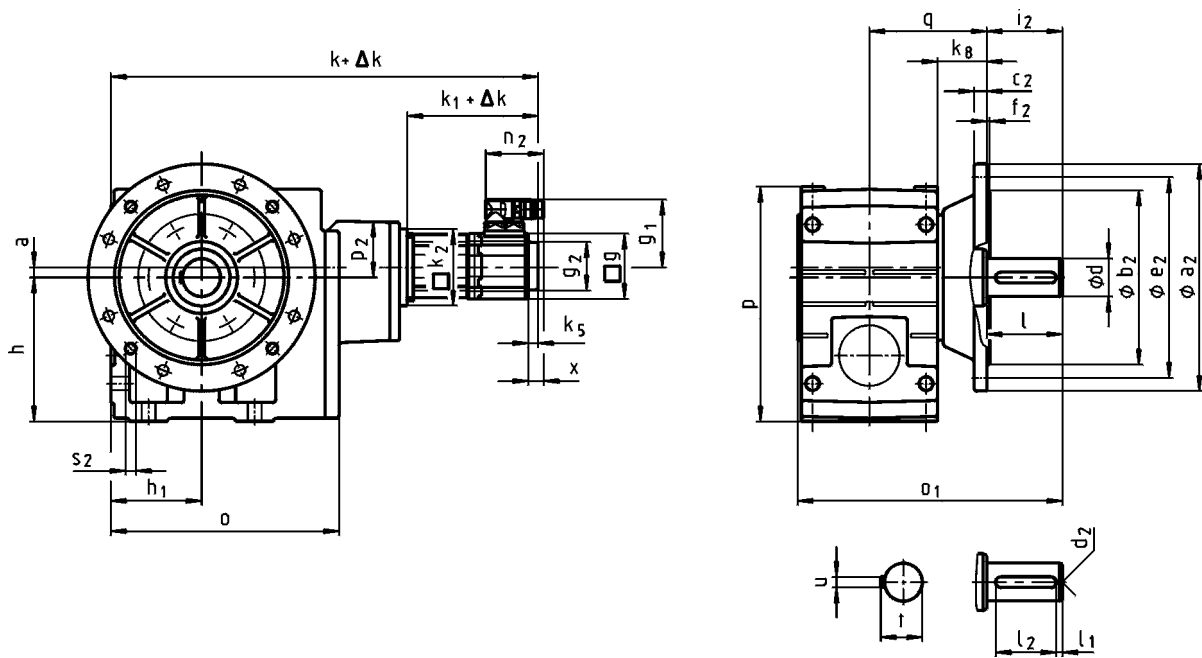

GSS□□-3S VAK ... RSO

		06C C41	06F C41	06I C41	09D C41	09F C38	09H C41	09L C41	12D C20	12D C41	12H C15	12H C30	12H C35	12L C20	12L C41	
GSS05...	k	423	453	483	476	496	516	556								
GSS06...	k	480	510	540	533	553	573	613								
GSS07...	k	534	564	594	587	607	627	667	604		644			684		
...RSO B0 ¹⁾	Δk	0														
...RSO P□ ¹⁾	Δk	19				20										
...RSO	k_1	132	162	192	183	203	223	263	188		228			268		
	k_2	66			91						118 145 ²⁾					
	g	62			89						116					
	k_5	0			13						14					
	g_2	□ 62			Ø 67						Ø 72					
	g_1	76			90						105					
	n_2	64									78					
	x				21						18					

¹⁾ → 801 - SRS / SRM / ECN / EQN / EQI / C20

²⁾ GSS07: 12DC20 ... 12LC41

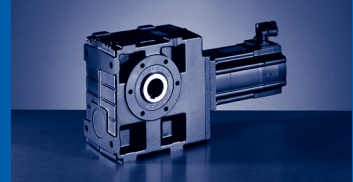

GSS□□-3S VAK

	o	o ₁	p	p ₂	h	h ₁	a	q	k ₈
GSS05...	209	230	205	65	125	80	13	103.5	40
GSS06...	252	277	250	63	150	100	10	121.5	49
GSS07...	299	351	310	73	190	120	12	155.5	66

	d	l	l ₁	l ₂	d ₂	u	t	a ₂	b ₂	c ₂	e ₂	f ₂	i ₂	s ₂
GSS05...	30	60	6	45	M10	8	33	200	130	12	165	3.5	60	4 x 11
GSS06...	40	80	7	63	M16	12	43	250	180	15	215	4	80	4 x 14
GSS07...	50	100	8	80		14	53.5						300	

d ≤ 50 mm: k6; d > 50 mm: m6

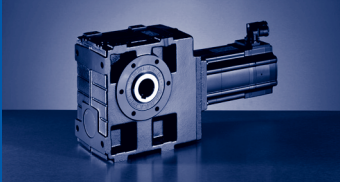

GSS [mm]

GSS□□-2A (MCA)

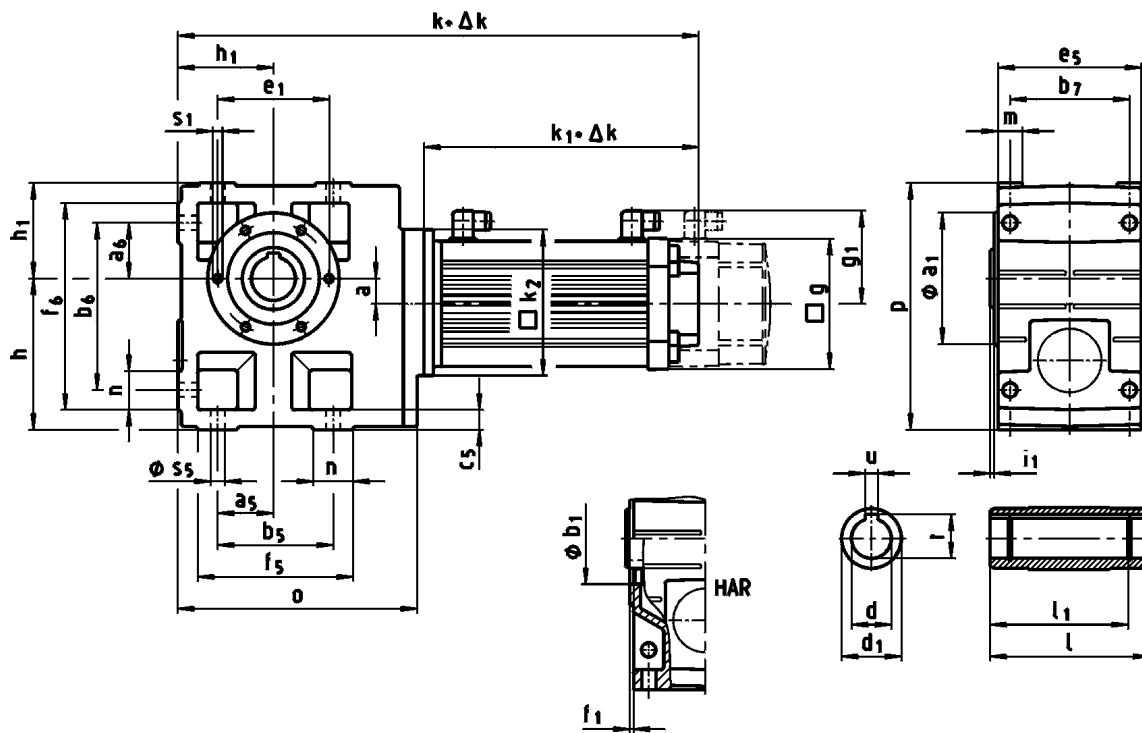

GSS□□-2A H□R ... RSO

		10I C40 ...S00	13I C41 ...S00	13I C34 ...F10	14L C20 ...S00	14L C41 ...S00	14L C16 ...F10	14L C35 ...F10	17N C23 ...S00	17N C41 ...S00
GSS04...	k	453	462	530						
GSS05...	k	475	483	551	533		595			
GSS06...	k	515	523	591	573		635		612	
GSS07...	k	558	566	634	616		678		655	
...RSO B0 ¹⁾	Δk	0								
...RSO P□ ¹⁾	Δk	25	35		33			35		
	k_1	258	267	335	307		369		346	
	k_2	145			180					
	g	102	131		142				165	
	g_1	90	102		109				118	

¹⁾ → 803 - SRS / SRM / ECN / EQN / EQI / S20 / T20 / CDD

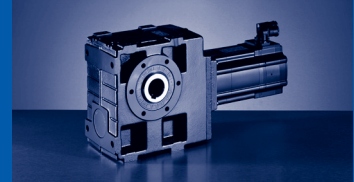

GSS□□-2A H□R ... RSO

		17N C17 ...F10	17N C35 ...F10	19S C23 ...S00	19S C42 ...S00	19S C17 ...F10	19S C35 ...F10	21X C25 ...S00	21X C42 ...S00	21X C17 ...F10	21X C35 ...F10
GSS06...	k	701				821		802		898	
GSS07...	k	744		724		821		802		898	
...RSO B0 ¹⁾	Δ k	0									
...RSO P□ ¹⁾	Δ k	35		38				42			
	k ₁	435		408		505		479		575	
	k ₂	180				222				265	
	g	165				192				214	
	g ₁	118				161				172	

¹⁾ →  803 - SRS / SRM / ECN / EQN / EQI / S20 / T20 / CDD

GSS□□-2A H□R

	o	p	h	h ₁	a	a ₅	a ₆	b ₅	b ₆	b ₇	c ₅	e ₅	f ₅	f ₆	m	n	s ₅
GSS04...	181	171	100	71	20	45	45	90	119	85	14	100	112	141	20	22	9
GSS05...	212	205	125	80	23	47.5	47.5	95	140	105	17	127	124	169	21	29	11
GSS06...	255	250	150	100	26	60	60	120	170	120	20	145	156	206	23	36	14
GSS07...	305	310	190	120	33	70	70	140	210	150	25	180	185	255	28	45	18

	d	l	d ₁	l ₁	u	t	a ₁	b ₁	e ₁	f ₁	i ₁	s ₁
	H7				JS9	+0,2		H7				6x60°
GSS04...	25	115	45	100	8	28.3	105	75	90	3	2.5	M6x12
	30					33.3						
GSS05...	35	140	50	124	10	38.3	118	80	100	4	4	M8x15
	40					43.3						
GSS06...	45	160	65	140	14	48.8	140	100	120	5	5	M10x16
	50					53.8						
GSS07...	55	200	75	175	16	59.3	165	115	140	5	5	M12x18

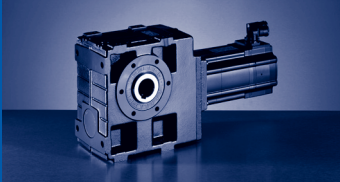

GSS [mm]

GSS□□-2A (MCA)

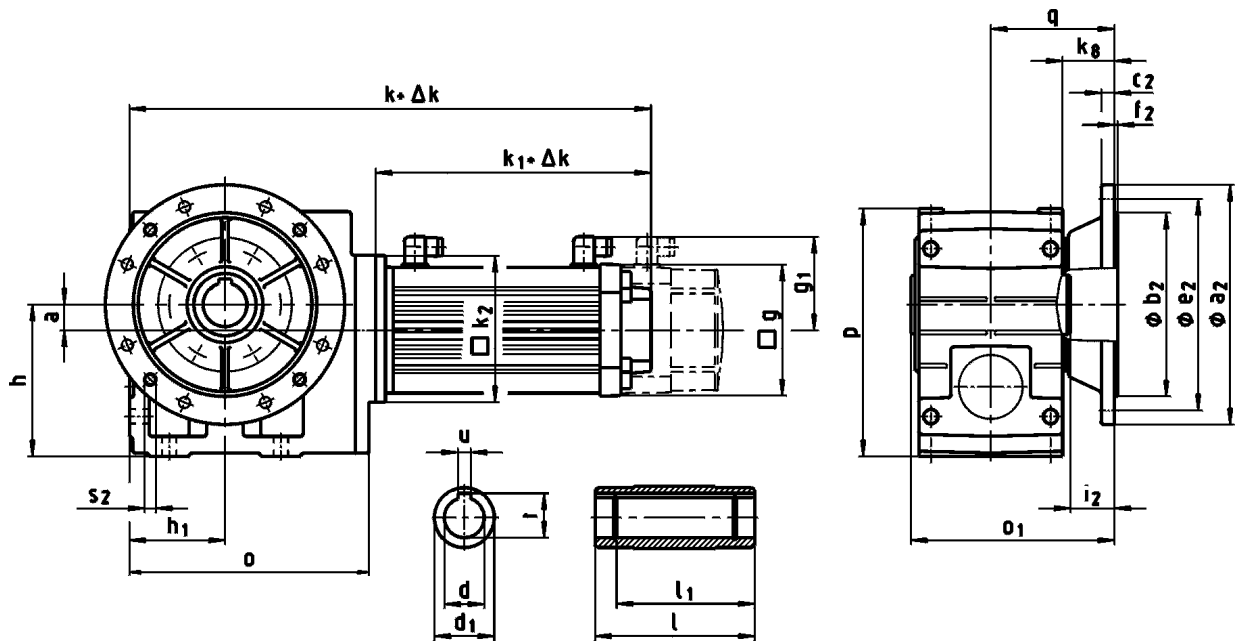

GSS□□-2A HAK ... RSO

		10I C40 ...S00	13I C41 ...S00	13I C34 ...F10	14L C20 ...S00	14L C41 ...S00	14L C16 ...F10	14L C35 ...F10	17N C23 ...S00	17N C41 ...S00
GSS04...	k	453	462	530						
GSS05...	k	475	483	551	533		595			
GSS06...	k	515	523	591	573		635		612	
GSS07...	k	558	566	634	616		678		655	
...RSO B0 ¹⁾	Δk	0								
...RSO P□ ¹⁾	Δk	25	35			33			35	
	k_1	258	267	335	307		369		346	
	k_2	145				180				
	g	102	131			142			165	
	g_1	90	102			109			118	

¹⁾ → 803 - SRS / SRM / ECN / EQN / EQI / S20 / T20 / CDD

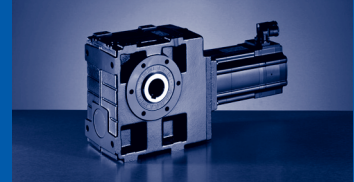

GSS□□-2A HAK ... RSO

		17N C17 ...F10	17N C35 ...F10	19S C23 ...S00	19S C42 ...S00	19S C17 ...F10	19S C35 ...F10	21X C25 ...S00	21X C42 ...S00	21X C17 ...F10	21X C35 ...F10
GSS06...	k	701				821		802		898	
GSS07...	k	744		724		821		802		898	
...RSO B0 ¹⁾	Δ k	0									
...RSO P□ ¹⁾	Δ k	35		38				42			
	k ₁	435		408		505		479		575	
	k ₂	180				222				265	
	g	165				192				214	
	g ₁	118				161				172	

¹⁾ → 803 - SRS / SRM / ECN / EQN / EQI / S20 / T20 / CDD

GSS□□-2A HAK

	o	o ₁	p	h	h ₁	a	q	k ₈
GSS04...	181	149	171	100	71	20	91	41
GSS05...	212	174	205	125	80	23	103.5	40
GSS06...	255	203 ²⁾ 202 ³⁾	250	150	100	26	122.5 ²⁾ 121.5 ³⁾	50 ²⁾ 49 ³⁾
GSS07...	305	256	310	190	120	33	155.5	66

²⁾ a₂ = 200

³⁾ a₂ = 250

	d	l	d ₁	l ₁	u	t	a ₂	b ₂	c ₂	e ₂	f ₂	i ₂	s ₂
	H7				JS9	+0,2		j7					
GSS04...	25	115	45	100	8	28.3	160	110	10	130	3.5	33.5	4 x 9
	30					33.3							
GSS05...	35	140	50	124	10	38.3	200	130	12	165	3.5	33.5	4 x 11
	40					43.3							
GSS06...	45	160	65	140	14	48.8	250	180	15	215	4	41.5	4 x 14
	50					53.8							
GSS07...	55	200	75	175	16	59.3	300	230	17	265	4	55.5	4 x 14

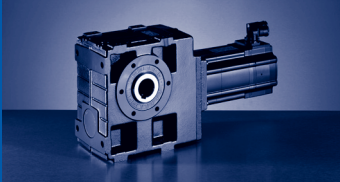

GSS [mm]

GSS□□-2A (MCA)

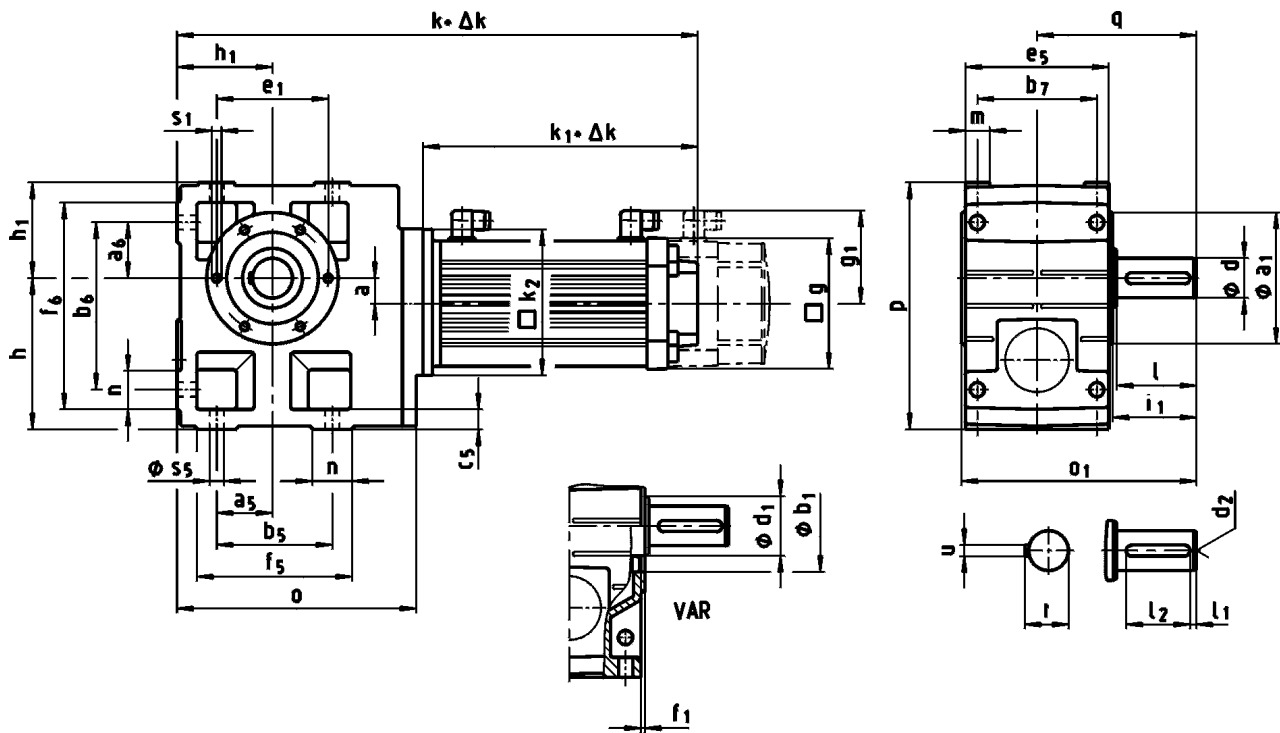

GSS□□-2A V□□ ... RSO

		10I C40 ...S00	13I C41 ...S00	13I C34 ...F10	14L C20 ...S00	14L C41 ...S00	14L C16 ...F10	14L C35 ...F10	17N C23 ...S00	17N C41 ...S00
GSS04...	k	453	462	530						
GSS05...	k	475	483	551	533		595			
GSS06...	k	515	523	591	573		635		612	
GSS07...	k	558	566	634	616		678		655	
...RSO B0 ¹⁾	Δk	0								
...RSO P□ ¹⁾	Δk	25	35			33			35	
	k_1	258	267	335	307		369		346	
	k_2	145				180				
	g	102	131			142			165	
	g_1	90	102			109			118	

¹⁾ → 803 - SRS / SRM / ECN / EQN / EQI / S20 / T20 / CDD

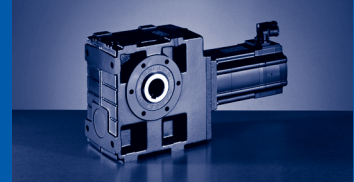

GSS□□-2A V□R ... RSO

		17N C17 ...F10	17N C35 ...F10	19S C23 ...S00	19S C42 ...S00	19S C17 ...F10	19S C35 ...F10	21X C25 ...S00	21X C42 ...S00	21X C17 ...F10	21X C35 ...F10
GSS06...	k	701				821		802		898	
GSS07...	k	744		724		821		802		898	
...RSO B0 ¹⁾	Δ k	0									
...RSO P□ ¹⁾	Δ k	35		38				42			
	k ₁	435		408		505		479		575	
	k ₂	180				222				265	
	g	165				192				214	
	g ₁	118				161				172	

¹⁾ →  803 - SRS / SRM / ECN / EQN / EQI / S20 / T20 / CDD

GSS□□-2A V□R

	o	o ₁	p	h	h ₁	a	q	a ₅	a ₆	b ₅	b ₆	b ₇	c ₅	e ₅	f ₅	f ₆	m	n	s ₅
GSS04...	181	163	171	100	71	20	107.5	45	45	90	119	85	14	100	112	141	20	22	9
GSS05...	212	197	205	125	80	23	130	47.5	47.5	95	140	105	17	127	124	169	21	29	11
GSS06...	255	236	250	150	100	26	160	60	60	120	170	120	20	145	156	206	23	36	14
GSS07...	305	296	310	190	120	33	200	70	70	140	210	150	25	180	185	255	28	45	18

	d	l	d ₁	l ₁	l ₂	d ₂	u	t	a ₁	b ₁	e ₁	f ₁	i ₁	s ₁
										H7				6x60°
GSS04...	25	50	45	4	40	M10	8	28	105	75	90	3	52.5	M6x12
GSS05...	30	60	50	6	45			33	118	80	100	4	64	M8x15
GSS06...	40	80	65	7	63	M16	14	43	140	100	120		85	M10x16
GSS07...	50	100	75	8	80			53.5	165	115	140	5	105	M12x18

d ≤ 50 mm: k6; d > 50 mm: m6

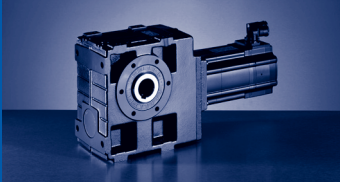

GSS [mm]

GSS□□-2A (MCA)

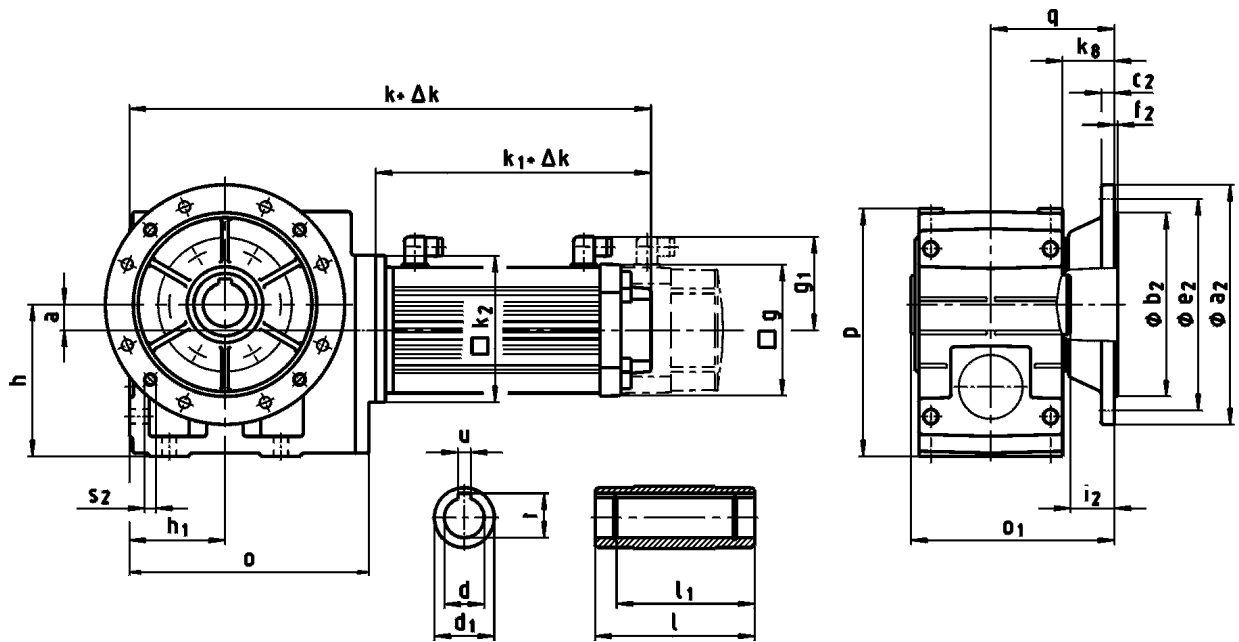

GSS□□-2A VAK ... RSO

		10I C40 ...S00	13I C41 ...S00	13I C34 ...F10	14L C20 ...S00	14L C41 ...S00	14L C16 ...F10	14L C35 ...F10	17N C23 ...S00	17N C41 ...S00
GSS04...	k	453	462	530						
GSS05...	k	475	483	551	533		595			
GSS06...	k	515	523	591	573		635		612	
GSS07...	k	558	566	634	616		678		655	
...RSO B0 ¹⁾	Δk	0								
...RSO P□ ¹⁾	Δk	25	35			33			35	
	k_1	258	267	335	307		369		346	
	k_2	145				180				
	g	102	131			142			165	
	g_1	90	102			109			118	

¹⁾ → 803 - SRS / SRM / ECN / EQN / EQI / S20 / T20 / CDD

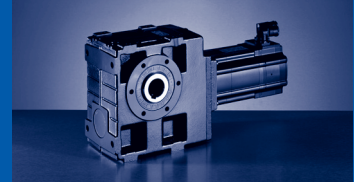

GSS□□-2A VAK ... RSO

		17N C17 ...F10	17N C35 ...F10	19S C23 ...S00	19S C42 ...S00	19S C17 ...F10	19S C35 ...F10	21X C25 ...S00	21X C42 ...S00	21X C17 ...F10	21X C35 ...F10
GSS06...	k	701				821		802		898	
GSS07...	k	744		724		821		802		898	
...RSO B0 ¹⁾	Δk	0									
...RSO P□ ¹⁾	Δk	35		38				42			
	k ₁	435		408		505		479		575	
	k ₂	180				222				265	
	g	165				192				214	
	g ₁	118				161				172	

¹⁾ →  803 - SRS / SRM / ECN / EQN / EQI / S20 / T20 / CDD

GSS□□-2A VAK

	o	o ₁	p	h	h ₁	a	q	k ₈
GSS04...	181	196	171	100	71	20	91	41
GSS05...	212	230	205	125	80	23	103.5	40
GSS06...	255	277	250	150	100	26	121.5	49
GSS07...	305	351	310	190	120	33	155.5	66

	d	l	l ₁	l ₂	d ₂	u	t	a ₂	b ₂	c ₂	e ₂	f ₂	i ₂	s ₂
GSS04...	25	50	4	40	M10	8	28	160	110	10	130	3.5	50	4 x 9
GSS05...	30	60	6	45			33	200	130	12	165		60	4 x 11
GSS06...	40	80	7	63	M16	14	43	250	180	15	215	4	80	4 x 14
GSS07...	50	100	8	80			53.5						300	

d ≤ 50 mm: k6; d > 50 mm: m6

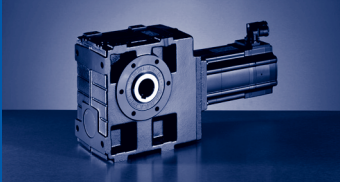

GSS [mm]

GSS□□-3A (MCA)

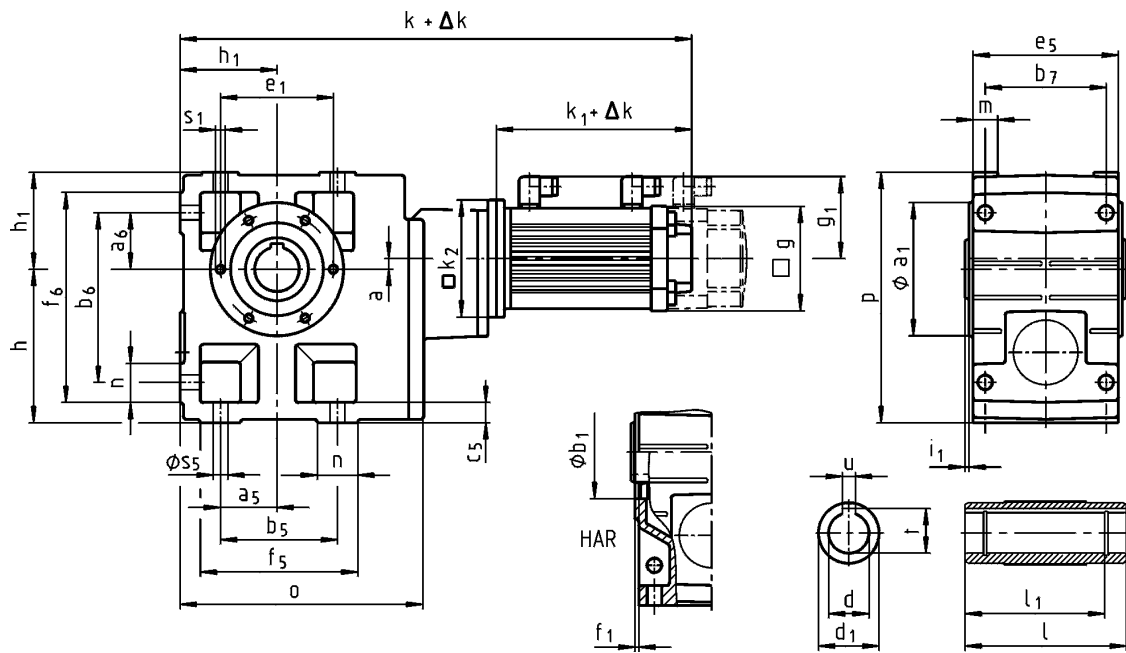

GSS□□-3A H□R ... RSO

		10I C40 ...S00	13I C41 ...S00	13I C34 ...F10	14L C20 ...S00	14L C41 ...S00	14L C16 ...F10	14L C35 ...F10
GSS05...	k	551	560	628				
GSS06...	k	608	617	685				
GSS07...	k	662	671	739		721		783
...RSO B0 ¹⁾	Δk	0						
...RSO P□ ¹⁾	Δk	25	35				33	
	k_1	258	267	335		307		369
	k_2		145				180	
	g	102	131				142	
	g_1	90	102				109	

¹⁾ → 803 - SRS / SRM / ECN / EQN / EQI / S20 / T20 / CDD

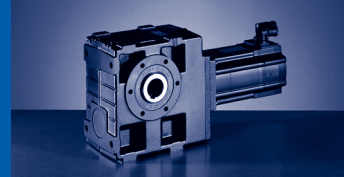

GSS□□-3A H□R

	o	p	h	h ₁	a	a ₅	a ₆	b ₅	b ₆	b ₇	c ₅	e ₅	f ₅	f ₆	m	n	s ₅
GSS05...	209	205	125	80	13	47.5	47.5	95	140	105	17	127	124	169	21	29	11
GSS06...	252	250	150	100	10	60	60	120	170	120	20	145	156	206	23	36	14
GSS07...	299	310	190	120	12	70	70	140	210	150	25	180	185	255	28	45	18

	d	l	d ₁	l ₁	u	t	a ₁	b ₁	e ₁	f ₁	i ₁	s ₁
	H7				JS9	+0,2		H7				6x60°
GSS05...	30	140	50	124	8	33.3	118	80	100	4	4	M8x15
	35				10	38.3						
GSS06...	40	160	65	140	12	43.3	140	100	120		5	M10x16
	45				14	48.8						
GSS07...	50	200	75	175	14	53.8	165	115	140	5	M12x18	
	55				16	59.3						

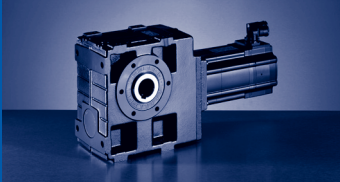

GSS [mm]

GSS□□-3A (MCA)

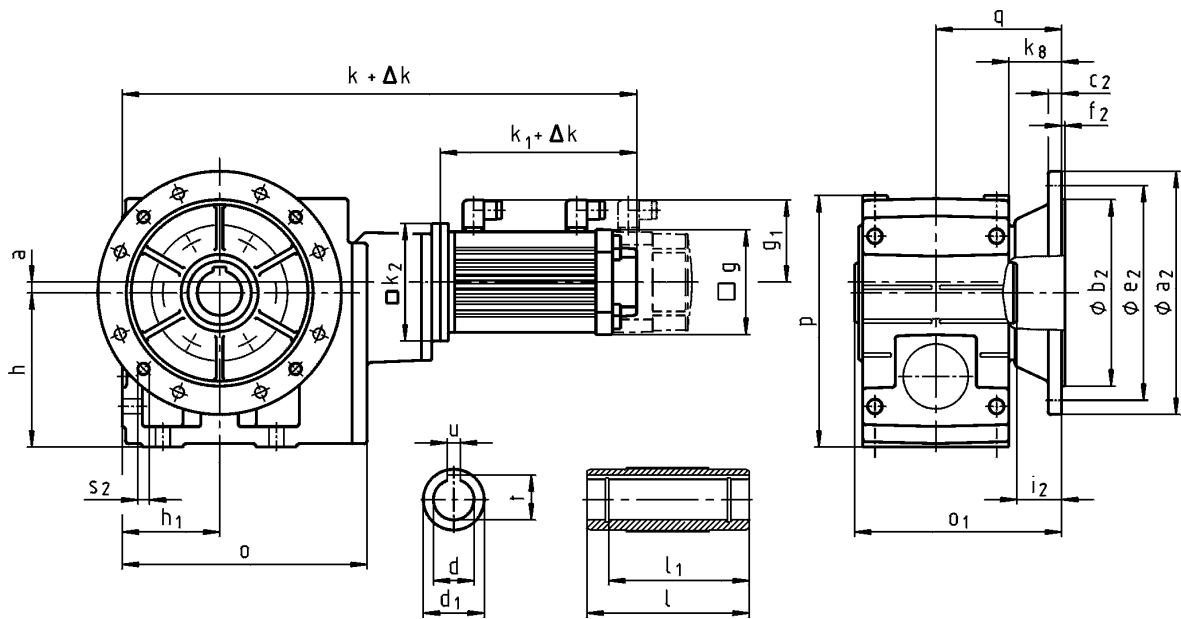

GSS□□-3A HAK ... RSO

		10I C40 ...S00	13I C41 ...S00	13I C34 ...F10	14L C20 ...S00	14L C41 ...S00	14L C16 ...F10	14L C35 ...F10
GSS05...	k	551	560	628				
GSS06...	k	608	617	685				
GSS07...	k	662	671	739		721		783
...RSO B0 ¹⁾	Δk	0						
...RSO P□ ¹⁾	Δk	25		35			33	
	k_1	258	267	335		307		369
	k_2		145				180	
	g	102		131			142	
	g_1	90		102			109	

¹⁾ → 803 - SRS / SRM / ECN / EQN / EQI / S20 / T20 / CDD

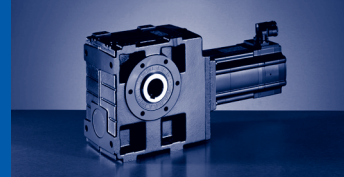

GSS□□-3A HAK

	o	o ₁	p	h	h ₁	a	q	k ₈
GSS05...	209	174	205	125	80	13	103.5	40
GSS06...	252	203 ¹⁾ 202 ²⁾	250	150	100	10	122.5 ¹⁾ 121.5 ²⁾	50 ¹⁾ 49 ²⁾
GSS07...	299	256	310	190	120	12	155.5	66

¹⁾ a₂ = 200

²⁾ a₂ = 250

	d	l	d ₁	l ₁	u	t	a ₂	b ₂	c ₂	e ₂	f ₂	i ₂	s ₂
	H7				JS9	+0,2		j7					
GSS05...	30	140	50	124	8	33.3	200	130	12	165	3.5	33.5	4 x 11
	35				10	38.3							
GSS06...	40	160	65	140	12	43.3	250	180	15	215	4	42.5	4 x 14
	45				14	48.8							
GSS07...	50	200	75	175		53.8	300	230	17	265	4	55.5	4 x 14
	55				16	59.3							

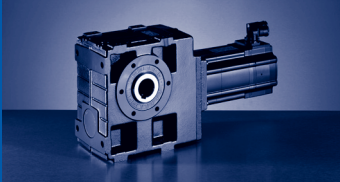

GSS [mm]

GSS□□-3A (MCA)

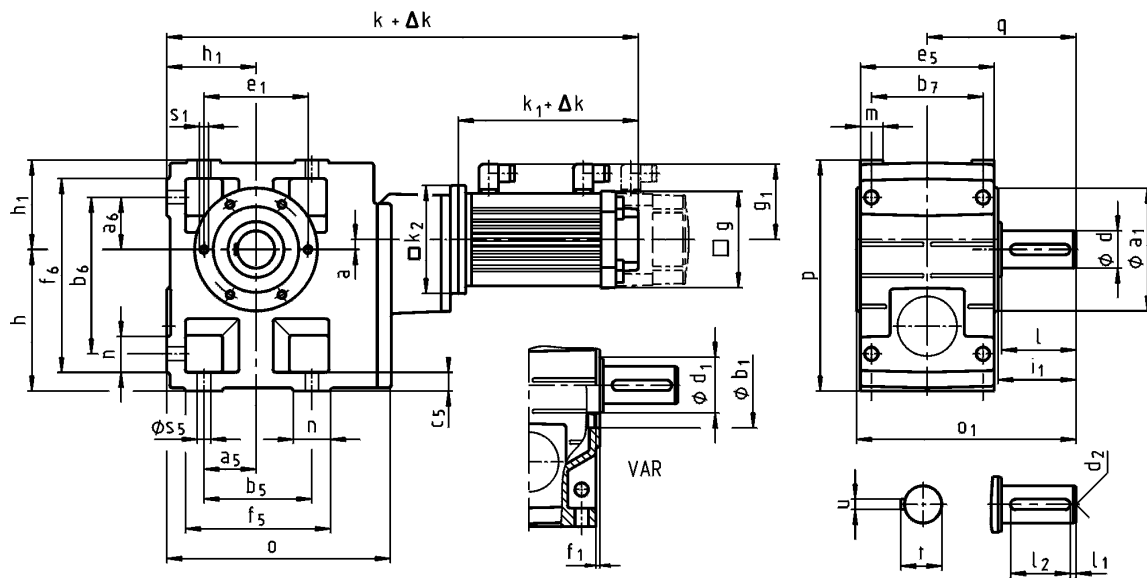

GSS□□-3A V□R ... RSO

		10I C40 ...S00	13I C41 ...S00	13I C34 ...F10	14L C20 ...S00	14L C41 ...S00	14L C16 ...F10	14L C35 ...F10
GSS05...	k	551	560	628				
GSS06...	k	608	617	685				
GSS07...	k	662	671	739	721		783	
...RSO B0 ¹⁾	Δk	0						
...RSO P□ ¹⁾	Δk	25	35				33	
	k_1	258	267	335	307		369	
	k_2	145					180	
	g	102	131				142	
	g_1	90	102				109	

¹⁾ → 803 - SRS / SRM / ECN / EQN / EQI / S20 / T20 / CDD

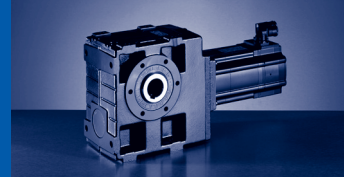

GSS□□-3A V□R

	o	o ₁	p	h	h ₁	a	q	a ₅	a ₆	b ₅	b ₆	b ₇	c ₅	e ₅	f ₅	f ₆	m	n	s ₅
GSS05...	209	197	205	125	80	13	130	47.5	47.5	95	140	105	17	127	124	169	21	29	11
GSS06...	252	236	250	150	100	10	160	60	60	120	170	120	20	145	156	206	23	36	14
GSS07...	299	296	310	190	120	12	200	70	70	140	210	150	25	180	185	255	28	45	18

	d	l	d ₁	l ₁	l ₂	d ₂	u	t	a ₁	b ₁	e ₁	f ₁	i ₁	s ₁
										H7				6x60°
GSS05...	30	60	50	6	45	M10	8	33	118	80	100	4	64	M8x15
GSS06...	40	80	65	7	63	M16	12	43	140	100	120		85	M10x16
GSS07...	50	100	75	8	80		14	53.5	165	115	140	5	105	M12x18

d ≤ 50 mm: k6; d > 50 mm: m6

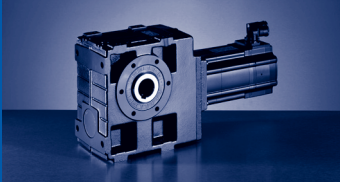

GSS [mm]

GSS□□-3A (MCA)

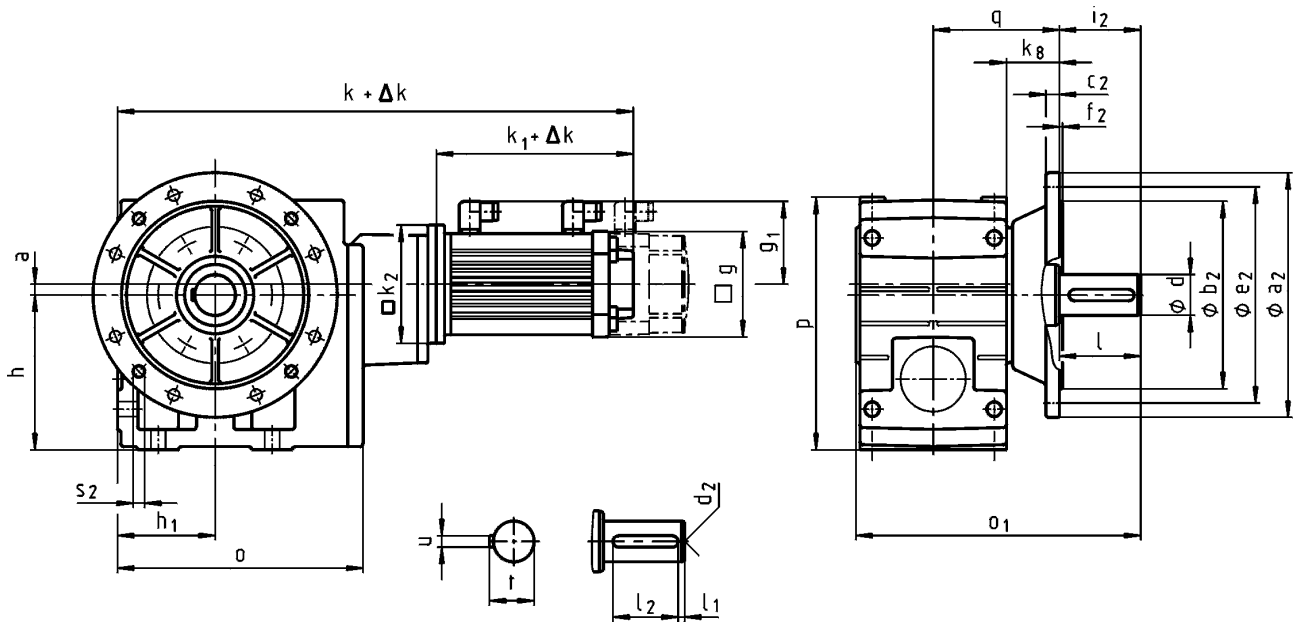

GSS□□-3A VAK ... RSO

		10I C40 ...S00	13I C41 ...S00	13I C34 ...F10	14L C20 ...S00	14L C41 ...S00	14L C16 ...F10	14L C35 ...F10
GSS05...	k	551	560	628				
GSS06...	k	608	617	685				
GSS07...	k	662	671	739		721		783
...RSO B0 ¹⁾	Δk	0						
...RSO P□ ¹⁾	Δk	25	35			33		
	k_1	258	267	335	307		369	
	k_2	145			180			
	g	102	131		142			
	g_1	90	102		109			

¹⁾ → 803 - SRS / SRM / ECN / EQN / EQI / S20 / T20 / CDD

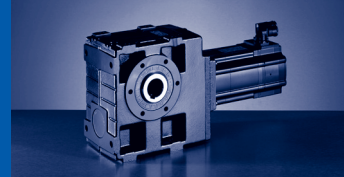

GSS□□-3A VAK

	o	o ₁	p	h	h ₁	a	q	k ₈
GSS05...	209	230	205	125	80	13	103.5	40
GSS06...	252	277	250	150	100	10	121.5	49
GSS07...	299	351	310	190	120	12	155.5	66

	d	l	l ₁	l ₂	d ₂	u	t	a ₂	b ₂	c ₂	e ₂	f ₂	i ₂	s ₂
GSS05...	30	60	6	45	M10	8	33	200	130	12	165	3.5	60	4 x 11
GSS06...	40	80	7	63	M16	12	43	250	180	15	215	4	80	4 x 14
GSS07...	50	100	8	80		14	53.5						300	

d ≤ 50 mm: k6; d > 50 mm: m6

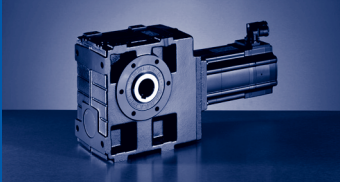

Hollow shaft with shrink disc

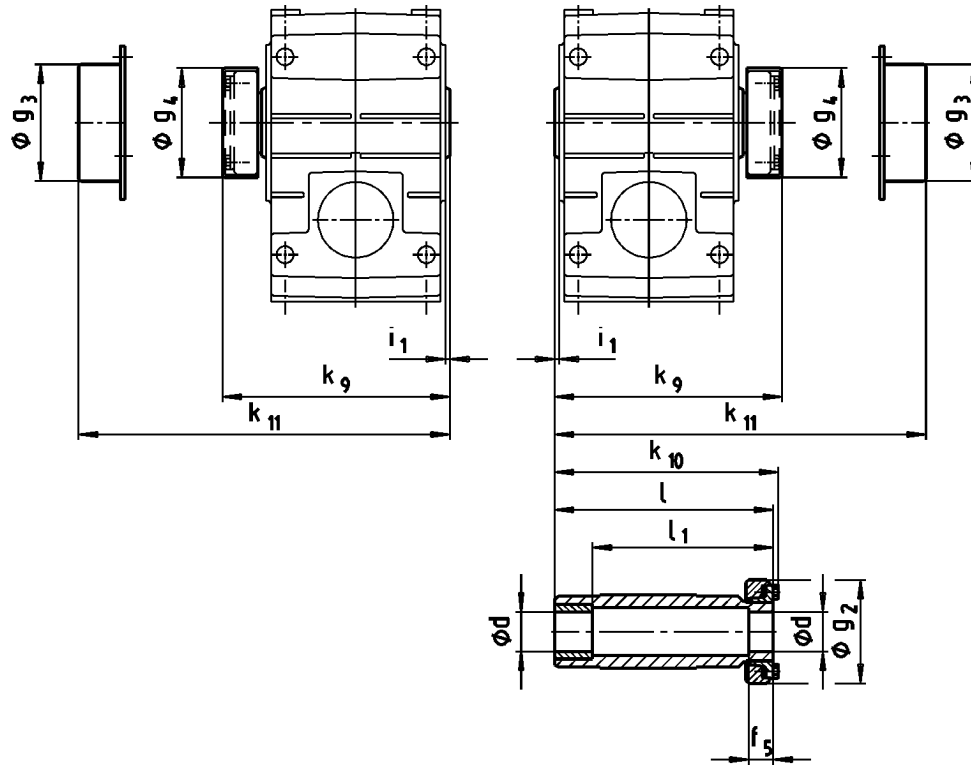

	Machine shaft	Hollow shaft with shrink disc						Protective cap		Cover	
	d	i_1	k_{10}	g_2	l	l_1	f_5	k_9	g_4	k_{11}	g_3
	h6										
GSS04...	25 30	2.5	147.5	72	142	122	26	149.5	76	154	79
GSS05...	35	4	173.5	80	168	148	28	175.5	84	179	90
GSS06...	40	5	199.5	90	194	164	30	201.5	94	204	100
GSS07...	50		237.5	110	232	192	26	240.5	116	244	124

- ▶ Ensure that the strength of the shaft material is adequate in shrink disc designs.
When using typical steels (e.g. C45, 42CrMo4), the torques listed in the selection tables can be used without restriction. When using material that is considerably weaker, please consult us. Medium surface roughness R_z must not exceed $15 \mu\text{m}$ (turning operation is sufficient).

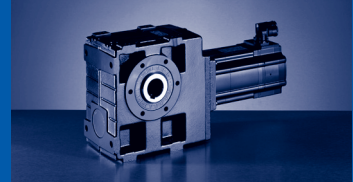

Hoseproof hollow shaft cover

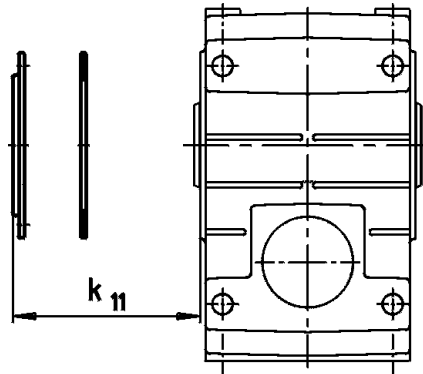

	Cover including seal
	k_{11}
GSS04...	9
GSS05...	10
GSS06...	11
GSS07...	11

Gearbox with 2nd output shaft end

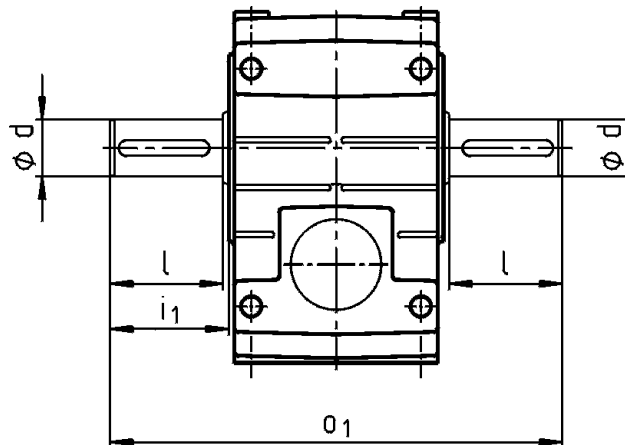

	d	l	i_1	o_1
GSS04...	25	50	52.5	215
GSS05...	30	60	64	260
GSS06...	40	80	85	320
GSS07...	50	100	105	400

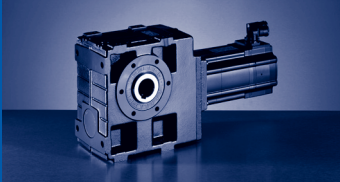

GSS & [mm]

Torque plate at threaded pitch circle in position 3

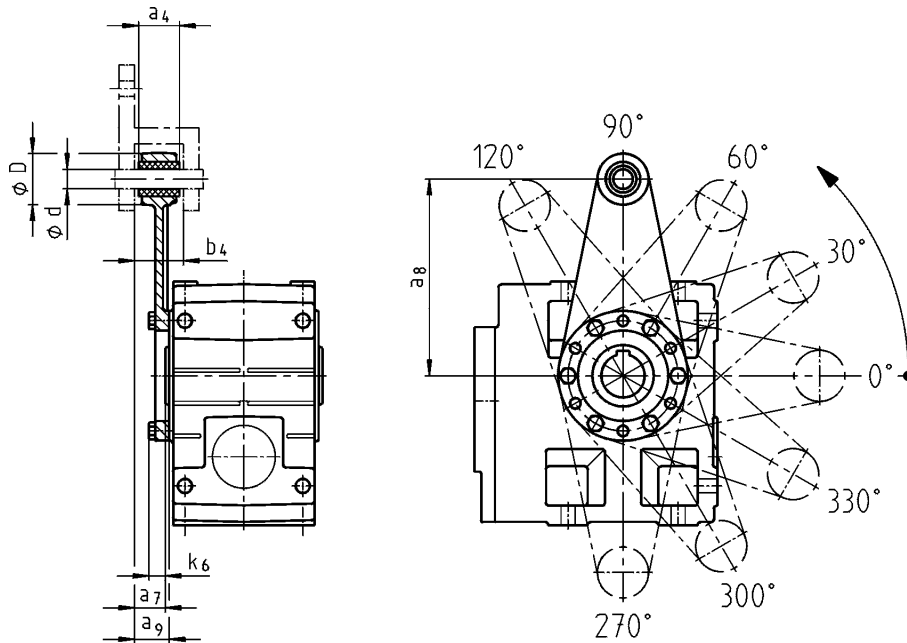

Torque plate at threaded pitch circle in position 5

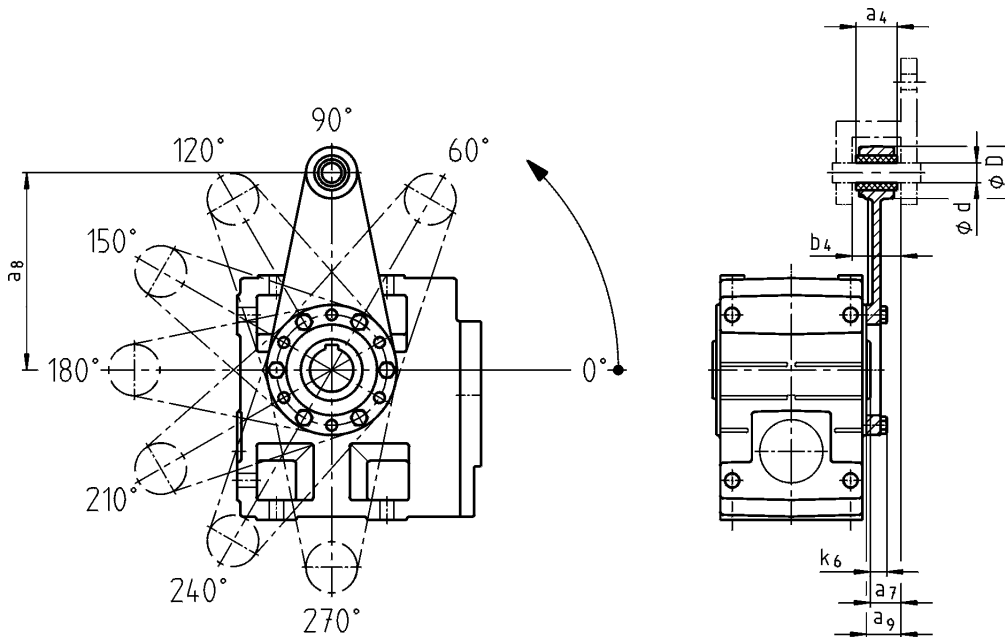

	Installation space							
	a ₇	b ₄	a ₄	a ₈	a ₉	d	D	k ₆
GSS04...	24	34.5	30	130	26.5	12	35	16
GSS05...	23.5	38.5	34	160	27.5	16	45	15
GSS06...	28	44.5	40	200	33	20	50	18
GSS07...	32.5	50.5	46	250	37.5	25	65	21

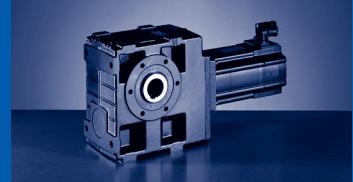

Torque plate at casing foot in position 2, 4 or 6

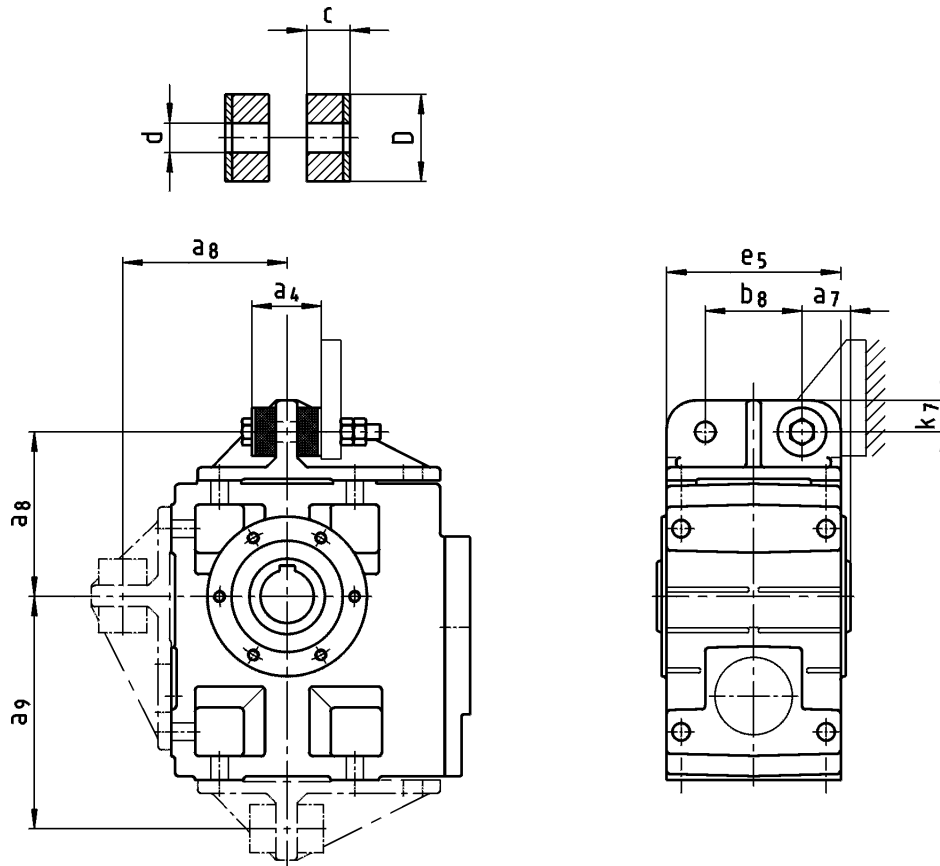

	a_4	a_7	a_8	a_9	b_8	c	d	D	e_5	k_7
GSS04...	41	27.5	106	135	60	14.5	11	30	100	20
GSS05...	45	35	115	160	70	15	13	40	127	25
GSS06...	72	40	145	195	80	27	17	50	145	28
GSS07...	78	50	170	240	100	28	21	60	180	35

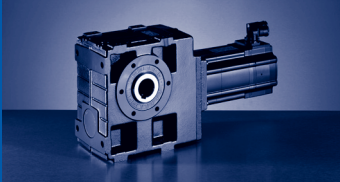

GSS & [mm]

Mounting set for hollow shaft circlip Proposed design for auxiliary tools

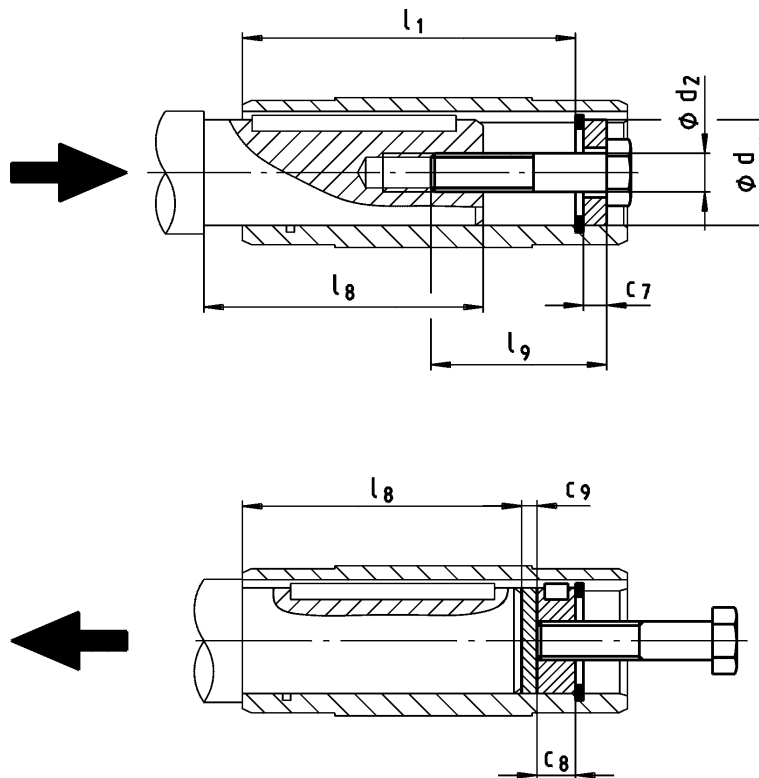

	Hollow shaft		Hollow shaft circlip mounting set (Assembly auxiliaries)			Auxiliary tools Disassembly		Machine shaft
	d	l_1	d_2	l_9	c_7	c_8	c_9	max l_8
	H7							
GSS04...	25	100	M10	40	5	10	3	85
	30				6			
GSS05...	35	124	M12	50	7	12	4	107
	40				8			
GSS06...	45	140	M16	60	9	16	5	118
	50				10			
GSS07...	55	175	M20	80	11	20	5	148

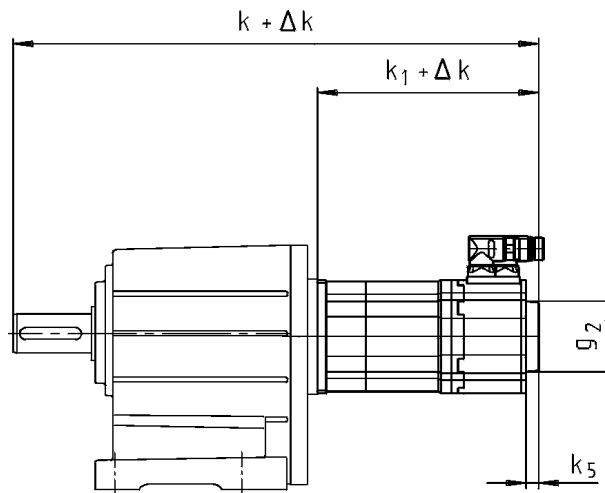
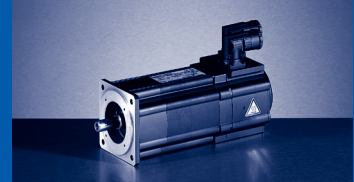

G□□...SRS / SRM / ECN / EQN / EQI / C20

		06C □41	06F □41	06I □41	09D □41	09F □38	09H □41	09L □41	12D □20	12D □41	12H □15	12H □30	12H □35	12L □20	12L □41
...SRS/SRM/ECN B0 ...EQN/EQI/C20 B0	Δ k	82			51			49							
...SRS/SRM/ECN P□ ...EQN/EQI/C20 P□	Δ k	100			71			69							
...S□□/E□□/C20	g ₂	□ 86			Ø 81			Ø 89							
	k ₅	82			64			63							

		14D □15	14D □36	14H □15	14H □32	14L □15	14L □32	14P □14	14P □32	19F □14	19F □30	19J □14	19J □30	19P □14	19P □30
...SRS/SRM/ECN B0 ...EQN/EQI/C20 B0	Δ k	50						49							
...SRS/SRM/ECN P□ ...EQN/EQI/C20 P□	Δ k	78						83		93					
...S□□/E□□/C20	g ₂	Ø 101													
	k ₅	74						64							

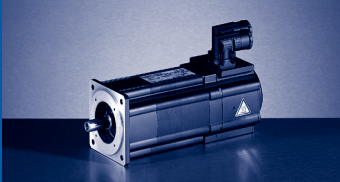

MCS & [mm]

Terminal box for motor connection

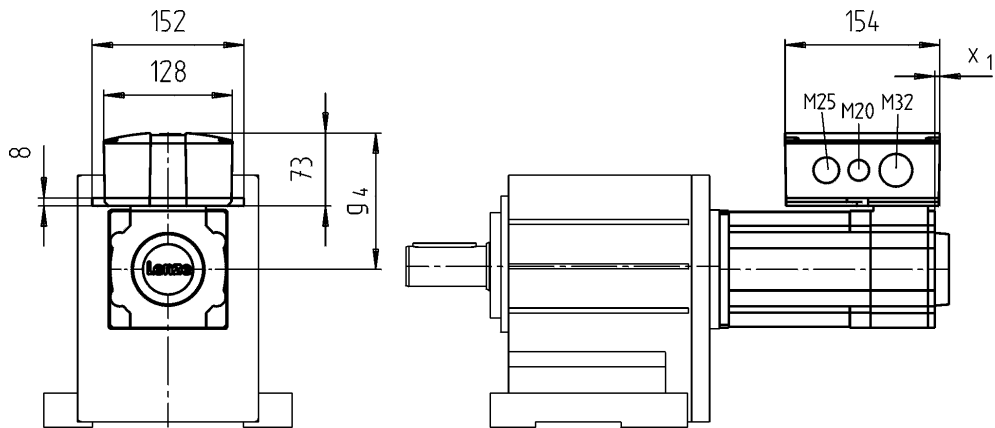

		09D □41	09F □38	09H □41	09L □41	12D □20	12D □41	12H □15	12H □30	12H □35	12L □20	12L □41				
Terminal box	g ₄	121					136									
	x ₁	8					5									
		14D □15	14D □36	14H □15	14H □32	14L □15	14L □32	14P □14	14P □32	19F □14	19F □30	19J □14	19J □30	19P □14	19P □30	
Terminal box	g ₄	147							172							
	x ₁	3														

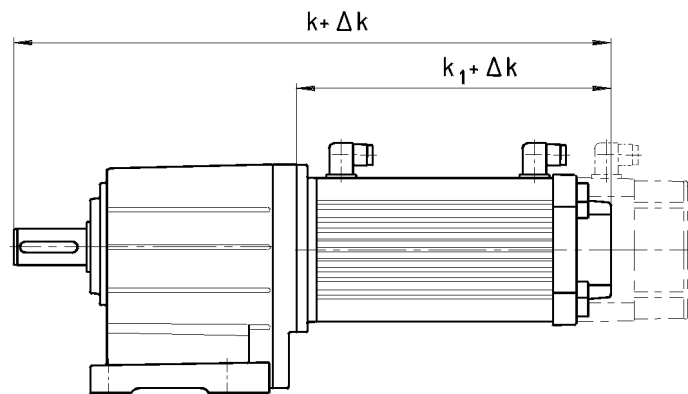
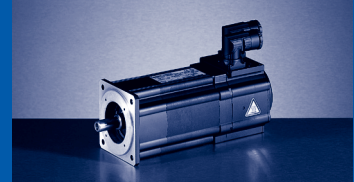

G□□...SRS / SRM / ECN / EQN / EQI / S20 / T20 / CDD

		10I □40 ...S00	13I □41 ...S00	13I □34 ...F10	14L □20 ...S00	14L □41 ...S00	14L □16 ...F10	14L □35 ...F10	17N □23 ...S00	17N □41 ...S00	
...SRS/SRM/ECN/EQN B0 ...EQI/S20/T20/CDD B0	Δ k	54			55			54			
...SRS/SRM/ECN/EQN P□ ...EQI/S20/T20/CDD P□	Δ k	79	89		88			89			
		17N □17 ...F10	17N □35 ...F10	19S □23 ...S00	19S □42 ...S00	19S □17 ...F10	19S □35 ...F10	21X □25 ...S00	21X □42 ...S00	21X □17 ...F10	21X □35 ...F10
...SRS/SRM/ECN/EQN B0 ...EQI/S20/T20/CDD B0	Δ k	54		50			49				
...SRS/SRM/ECN/EQN P□ ...EQI/S20/T20/CDD P□	Δ k	89		88			91				

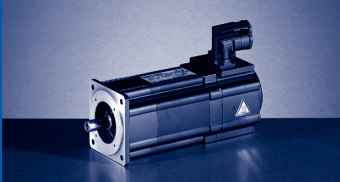

MCA & [mm]

Connectors for motor connection

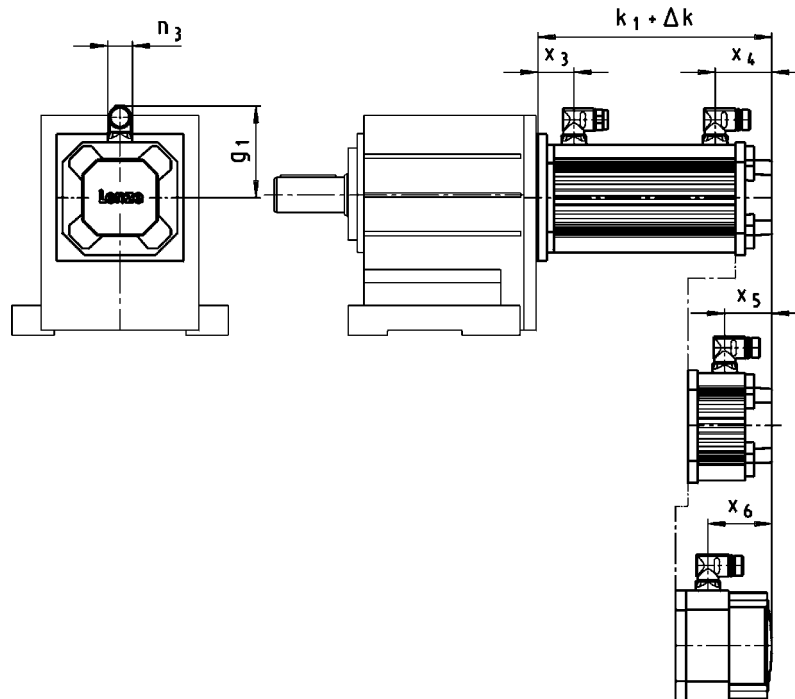

GST/GFL/GKR/GKS/GSS□□-□A

		10I C40 ...S00	13I C41 ...S00	13I C34 ...F10	14L C20 ...S00	14L C41 ...S00	14L C16 ...F10	14L C35 ...F10	17N C23 ...S00	17N C41 ...S00	
	k_1	258	267	335	307		369		346		
	g_1	90	102		109				118		
	n_3					28					
	x_6	-		73	-		67		-		
...RSO B0	Δk					0					
	x_3	38	41		46				49		
	x_4	61	65	133	73	135		73			
...RSO P□	Δk	25	35		33				35		
	x_3	55	68		73				81		
	x_4	61	65	133	73	135		73			
...SRS/SRM/ECN/EQN B0 ...EQI/S20/T20/CDD B0	Δk	54				55		54			
	x_3	38	41		46				49		
	x_4	-	119	187	127	189		127			
	x_5	54			-						
...SRS/SRM/ECN/EQN P□ ...EQI/S20/T20/CDD P□	Δk	79	89		88				89		
	x_3	55	68		73				81		
	x_4	-	119	187	127	189		127			
	x_5	54			-						

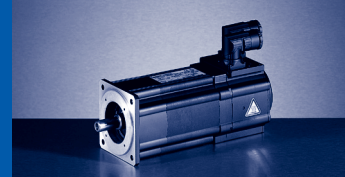

Connectors for motor connection

GST/GFL/GKR/GKS/GSS□□-□A

		17N C17 ...F10	17N C35 ...F10	19S C23 ...S00	19S C42 ...S00	19S C17 ...F10	19S C35 ...F10	21X C25 ...S00	21X C42 ...S00	21X C17 ...F10	21X C35 ...F10
	k_1	435		408		505		479		575	
	g_1	118			161				172		
	n_3	28					45				
	x_6	95		-		103		-		96	
...RSO B0	Δk					0					
	x_3	49			63				71		
	x_4	162		73		170		78		174	
...RSO P□	Δk	35			38				42		
	x_3	81			98				111		
	x_4	162		73		170		78		174	
...SRS/SRM/ECN/EQN B0 ...EQI/S20/T20/CDD B0	Δk	54			50				49		
	x_3	49			63				71		
	x_4	216		123		220		126		222	
	x_5					-					
...SRS/SRM/ECN/EQN P□ ...EQI/S20/T20/CDD P□	Δk	89			88				91		
	x_3	81			98				111		
	x_4	216		123		220		126		222	
	x_5					-					

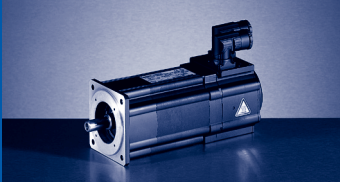

MCA & [mm]

Connectors for motor connection

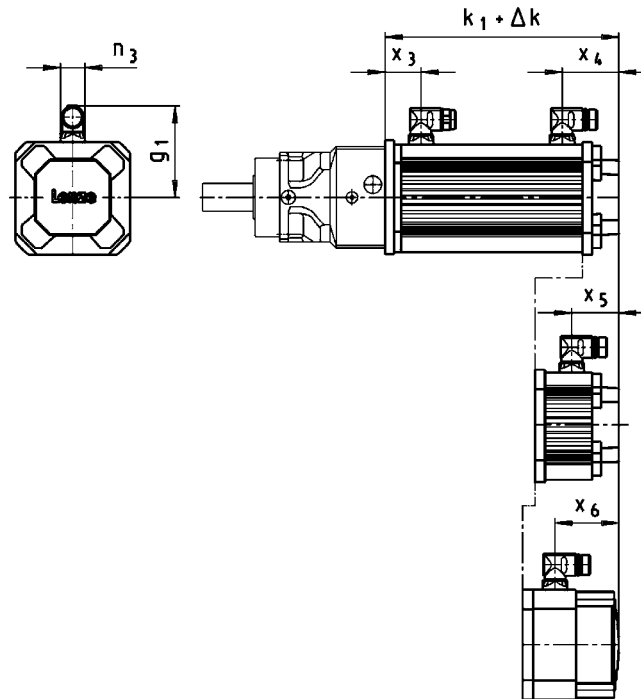

GPA□□-□A

		10I N40 ...S00	13I N41 ...S00	13I N34 ...F10	14L N20 ...S00	14L N41 ...S00	14L N16 ...F10	14L N35 ...F10	17N N23 ...S00	17N N41 ...S00	
	k_1	262	271	339	302		364		340		
	g_1	90	102				109		118		
	n_3					28					
	x_6	-		73	-		67		-		
...RSO B0	Δk					0					
	x_3	42	45				41		43		
	x_4	61	65	133	73		135		73		
...RSO P□	Δk	25	35				33		35		
	x_3	59	72				68		75		
	x_4	61	65	133	73		135		73		
...SRS/SRM/ECN/EQN B0 ...EQI/S20/T20/CDD B0	Δk	54				55		54			
	x_3	42	45				41		43		
	x_4	-	119	187	127		189		127		
	x_5	54						-			
...SRS/SRM/ECN/EQN P□ ...EQI/S20/T20/CDD P□	Δk	79	89				88		89		
	x_3	59	72				68		75		
	x_4	-	119	187	127		189		127		
	x_5	54						-			

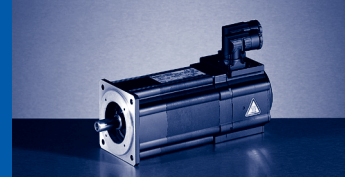

Connectors for motor connection

GPA□□-□A

		17N N17 ...F10	17N N35 ...F10	19S N23 ...S00	19S N42 ...S00	19S N17 ...F10	19S N35 ...F10	21X N25 ...S00	21X N42 ...S00	21X N17 ...F10	21X N35 ...F10
	k_1	429		401		498		470		566	
	g_1	118			161				172		
	n_3	28					45				
	x_6	95		-		103		-		96	
...RSO B0	Δk					0					
	x_3	43			56				62		
	x_4	162		73		170		78		174	
...RSO P□	Δk	35			38				42		
	x_3	75			91				102		
	x_4	162		73		170		78		174	
...SRS/SRM/ECN/EQN B0 ...EQI/S20/T20/CDD B0	Δk	54			50				49		
	x_3	43			56				62		
	x_4	216		123		220		126		222	
	x_5					-					
...SRS/SRM/ECN/EQN P□ ...EQI/S20/T20/CDD P□	Δk	89			88				91		
	x_3	75			91				102		
	x_4	216		123		220		126		222	
	x_5					-					

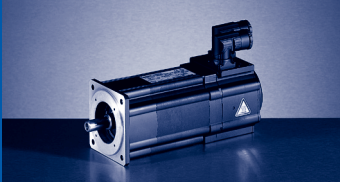

MCA & [mm]

Terminal box for motor connection

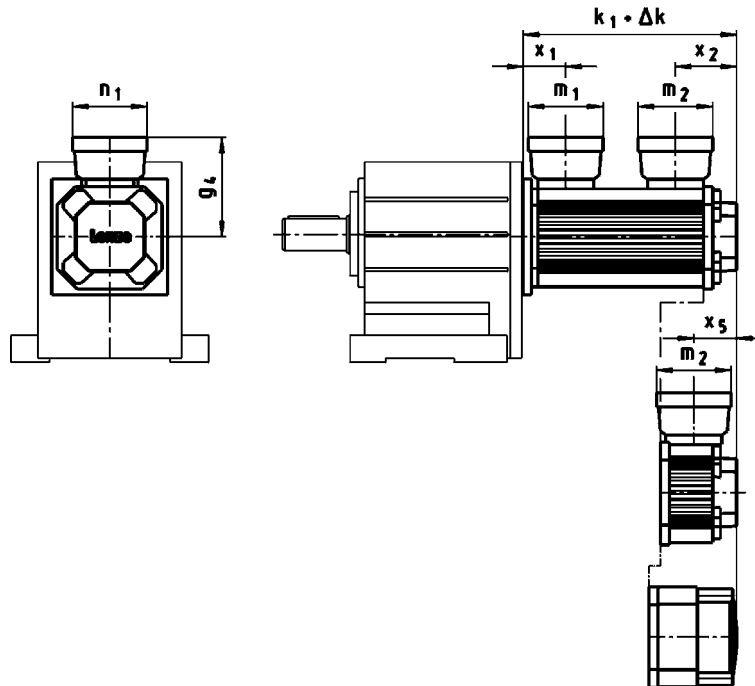

GST/GFL/GKR/GKS/GSS□□-□A

		10L C40 ...S00	13L C41 ...S00	13L C34 ...F10	14L C20 ...S00	14L C41 ...S00	14L C16 ...F10	14L C35 ...F10	17N C23 ...S00	17N C41 ...S00	
	k_1	258	267	335	307		369		346		
	g_4	113	125		132				140		
	m_1					93					
	m_2					93					
	n_1					93					
	x_1	60	53		58				61		
...RSO B0	Δk					0					
...RSO P□	x_2	78	77	145	85		147		85		
	Δk	25	35		33				35		
...SRS/SRM/ECN/EQN B0 ...EQI/S20/T20/CDD B0	x_2	78	77	145	85		147		85		
	Δk	54				55		54			
	x_2	-	131	199	139		201		139		
	x_5	50									
...SRS/SRM/ECN/EQN P□ ...EQI/S20/T20/CDD P□	Δk	79	89		88				89		
	x_2	-	131	199	139		201		139		
Terminal box in position 2 Cable glands in position 5	x_5	50									
						1 x M16x1.5		1 x M20x1.5			

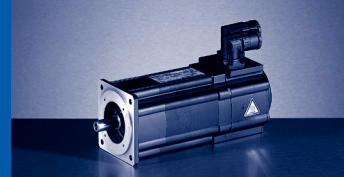

Terminal box for motor connection

GST/GFL/GKR/GKS/GSS□□-□A

		17N C17 ...F10	17N C35 ...F10	19S C23 ...S00	19S C42 ...S00	19S C17 ...F10	19S C35 ...F10	21X C25 ...S00	21X C42 ...S00	21X C17 ...F10	21X C35 ...F10
	k_1	435		408		505		479		575	
	g_4	140			158				169		
	m_1	93					120				
	m_2	93		93 ¹⁾ 120 ²⁾		93		93 ¹⁾ 120 ²⁾		93	
	n_1	93					109				
	x_1	61			80				93		
...RSO B0	Δk					0					
	x_2	174		93 ¹⁾ 87 ²⁾		190		97 ¹⁾ 92 ²⁾		193	
	Δk	35			38				42		
	x_2	174		93 ¹⁾ 87 ²⁾		190		97 ¹⁾ 92 ²⁾		193	
	Δk	54			50				49		
	x_2	228		143 ¹⁾ 137 ²⁾		240		146 ¹⁾ 140 ²⁾		242	
	x_5					-					
	Δk	89			88				91		
	x_2	228		143 ¹⁾ 137 ²⁾		240		146 ¹⁾ 140 ²⁾		242	
	x_5					-					
	Terminal box in position 2 Cable glands in position 5	1 x M16x1.5 1 x M20x1.5		1 x M16x1.5 ¹⁾ 1 x M20x1.5 ¹⁾ 1 x M25x1.5 ²⁾ 1 x M32x1.5 ²⁾		1 x M16x1.5 1 x M20x1.5		1 x M16x1.5 ¹⁾ 1 x M20x1.5 ¹⁾ 1 x M25x1.5 ²⁾ 1 x M32x1.5 ²⁾		1 x M16x1.5 1 x M20x1.5	

1) IP 54

2) IP 65

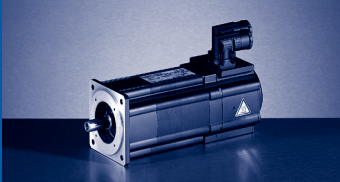

MCA & [mm]

Terminal box for motor connection

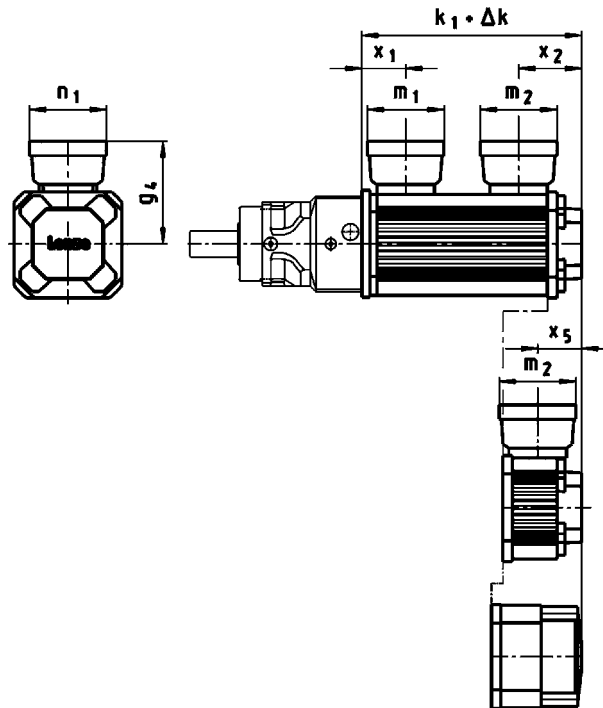

GPA□□-□A

		10I N40 ...S00	13I N41 ...S00	13I N34 ...F10	14L N20 ...S00	14L N41 ...S00	14L N16 ...F10	14L N35 ...F10	17N N23 ...S00	17N N41 ...S00	
	k_1	262	271	339	302		364		340		
	g_4	113	125		132				140		
	m_1					93					
	m_2					93					
	n_1					93					
	x_1	54	57		53				55		
...RSO B0	Δk					0					
	x_2	78	77	145	85		147		85		
...RSO P□	Δk	25	35		33				35		
	x_2	78	77	145	85		147		85		
...SRS/SRM/ECN/EQN B0 ...EQI/S20/T20/CDD B0	Δk	54				55				54	
	x_2	-	131	199	139		201		139		
	x_5	50									
...SRS/SRM/ECN/EQN P□ ...EQI/S20/T20/CDD P□	Δk	79	89		88				89		
	x_2	-	131	199	139		201		139		
	x_5	50									
Terminal box in position 2 Cable glands in position 5						1 x M16x1.5 1 x M20x1.5					

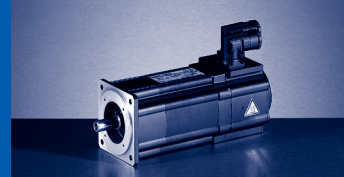

Terminal box for motor connection

GPA□□-□A

		17N N17 ...F10	17N N35 ...F10	19S N23 ...S00	19S N42 ...S00	19S N17 ...F10	19S N35 ...F10	21X N25 ...S00	21X N42 ...S00	21X N17 ...F10	21X N35 ...F10
	k_1	429		401		498		470		566	
	g_4	140		158			169				
	m_1	93		120							
	m_2	93		93 ¹⁾ 120 ²⁾		93		93 ¹⁾ 120 ²⁾		93	
	n_1	93		109							
	x_1	55		73			84				
...RSO B0	Δk	0									
	x_2	174		93 ¹⁾ 87 ²⁾		190		97 ¹⁾ 92 ²⁾		193	
	Δk	35		38			42				
	x_2	174		93 ¹⁾ 87 ²⁾		190		97 ¹⁾ 92 ²⁾		193	
	Δk	54		50			49				
	x_2	228		143 ¹⁾ 137 ²⁾		240		146 ¹⁾ 140 ²⁾		242	
	x_5	-									
...SRS/SRM/ECN/EQN P□ ...EQI/S20/T20/CDD P□	Δk	89		88			91				
	x_2	228		143 ¹⁾ 137 ²⁾		240		146 ¹⁾ 140 ²⁾		242	
	x_5	-									
Terminal box in position 2 Cable glands in position 5		1 x M16x1.5 1 x M20x1.5		1 x M16x1.5 ¹⁾ 1 x M20x1.5 ¹⁾ 1 x M25x1.5 ²⁾ 1 x M32x1.5 ²⁾		1 x M16x1.5 1 x M20x1.5		1 x M16x1.5 ¹⁾ 1 x M20x1.5 ¹⁾ 1 x M25x1.5 ²⁾ 1 x M32x1.5 ²⁾		1 x M16x1.5 1 x M20x1.5	

1) IP 54

2) IP 65



Lenze worldwide

LENZE AG

Postfach 10 13 52
D-31763 Hameln
Telefon +49 (0)51 54/82-0
Telefax +49 (0)51 54/82-28 00
E-Mail: Lenze@Lenze.de
Internet: www.Lenze.com

Lenze Drive Systems GmbH

Postfach 10 13 52, D-31763 Hameln
Telefon +49 (0)51 54/82-0
Telefax +49 (0)51 54/82-28 00

Lenze GmbH & Co KG Anlagenbau

Buchenweg 1
D-31855 Aerzen
Telefon +49 (0)51 54/82-0
Telefax +49 (0)51 54/82-21 00

Lenze GmbH & Co KG Kleinantriebe

Hans-Lenze-Straße 1
D-32699 Extertal
Telefon +49 (0)51 54/82-0
Telefax +49 (0)51 54/82-14 85

Lenze Service GmbH

Breslauer Straße 3
D-32699 Extertal
Mechanical Drives
Telefon +49 (0)51 54/82-16 26
Telefax +49 (0)51 54/82-13 96

Electronic Drives

Telefon +49 (0)51 54/82-11 11
Telefax +49 (0)51 54/82-11 12

Service Helpline

+49 (0)180 5 20 24 26

Lenze Verbindungstechnik GmbH

IpF-Landesstraße 1
A-4481 ASTEN
Telefon +43 (0)72 24 / 210-0
Telefax +43 (0)72 24 / 210-998

Lenze DETO Drive Systems GmbH & Co KG

Gewerbepark Süd 11
A-6330 Kufstein
Telefon +43 (0)53 72 / 6 53 15-200
Telefax +43 (0)53 72 / 6 53 15-299

Lenze Digitec Controls GmbH

Grünstraße 36
D-40667 Meerbusch
Telefon +49 (0)21 32 / 99 04-0
Telefax +49 (0)21 32 / 7 21 90

Schmidhauser AG

Obere Neustrasse 1
CH-8590 Romanshorn
Telefon +41 (0)71 466 11 11
Telefax +41 (0)71 466 11 10

encoway GmbH

Buschhöhe 2
D-28357 Bremen
Telefon +49 (0)4 21 / 2 46 77-0
Telefax +49 (0)4 21 / 2 46 77-10

DEUTSCHLAND/GERMANY

Lenze Vertrieb GmbH

Ludwig-Erhard-Straße 52-56
D-72760 Reutlingen
Telefon +49 (0)71 21 / 9 39 39-0
Telefax +49 (0)71 21 / 9 39 39-29

Region Nord
Dornenpark 1
31840 Hessisch Oldendorf
Telefon (0 51 52) 90 36-0
Telefax (0 51 52) 90 36-33/44/55

Region West
Postfach 10 12 20
47497 Neukirchen-Vluyn
Kelvinstraße 7
47506 Neukirchen-Vluyn
Telefon (0 28 45) 95 93-0
Telefax (0 28 45) 95 93 93

Region Mitte/Ost
Postfach 1463
35724 Herbborn
Austraße 81
35745 Herbborn
Telefon (0 27 72) 95 94-0
Telefax (0 27 72) 5 30 79

Region Südwest
Postfach 14 33
71304 Waiblingen
Schänzle 8
71332 Waiblingen
Telefon (0 71 51) 9 59 81 - 0
Telefax (0 71 51) 9 59 81 50

Region Süd
Fraunhoferstraße 16
82152 Martinsried
Telefon (0 89) 89 56 14-0
Telefax (0 89) 89 56 14 14

WELTWEIT/WORLDWIDE

ALGERIA

see FRANCE

ARGENTINA *

E.R.H.S.A.
Girardot 1368, 1427 BUENOS AIRES
Phone +54 (0)11 / 45 54 32 32
Telefax +54 (0)11 / 45 52 36 11

AUSTRALIA *

FCR Motion Technology Pty. Ltd.
Unit 6, Automation Place
38-40 Little Boundary Rd.
LAVERTON NORTH, Vic. 3026
Phone +61 (3) 9362 6800
Telefax +61 (3) 9314 3744

AUSTRIA *

Lenze Antriebstechnik GmbH
IpF-Landesstraße 1
4481 ASTEN
Phone +43 (0)7224 / 210-0
Telefax +43 (0)7224 / 210-999
Office Dornbirn:
Lustenauer Straße 64
6850 DORNBIERN
Phone +43 (0)7224 / 210-0
Telefax +43 (0)7224 / 210-7299

Office Wr. Neudorf:
Triester Straße 14/109
2351 WR. NEUDORF
Phone +43 (0)7224 / 210-0
Telefax +43 (0)7224 / 210-7099

Office Graz:
Seering 8
8141 ÜNTERPREMSTÄTTEN
Phone +43 (0)7224 / 210-0
Telefax +43 (0)7224 / 210-7199

Lenze Verbindungstechnik GmbH
IpF-Landesstraße 1
4481 ASTEN
Phone +43 (0)7224 / 210-0
Telefax +43 (0)7224 / 210-998

Lenze Anlagentechnik GmbH
Mühlenstraße 3
4470 ENNS
Phone +43 (0)7224 / 210-0
Telefax +43 (0)7224 / 210-997

BELARUS

see POLAND

BELGIUM *

Lenze bv.b.a
Noorderlaan 133
bus 15, 2030 ANTWERPEN
Phone +32 (0)3 / 54 26 20 0
Telefax +32 (0)3 / 54 13 75 4

BOSNIA-HERZEGOVINA

see AUSTRIA

BRAZIL *

AC Control Ltda
Rua Gustavo da Silveira 1199
Vila Sta. Catarina
SÃO PAULO – S.P. 04376-000
Phone +55 (11) 55 64 65 79 ramal: 214
Telefax +55 (11) 56 79 75 10

BULGARIA

Lenze Zadvizhvasta Tehnika EOOD
Bul. Maritza 21, Office 204
4003 PLOVDIV
Phone +359 / 32 / 940 373
Telefax +359 / 32 / 940 349

CANADA *

see USA

CHILE

Sargent S.A.
Tecnica Thomas C. Sargent
S.A.C.É.L., Casilla 166-D
SANTIAGO DE CHILE
Phone +56 (0)2 / 51 03 000
Telefax +56 (0)2 / 69 83 989

CHINA *

Lenze Mechatronic Drives
(Shanghai) Co. Ltd.
50 B, 199 North Ri Ying Road,
Waigaoqiao FTZ
SHANGHAI, 200131
Phone +86-21-5046 0848
Telefax +86-21-5046 2833

Shanghai Office
Rm. 2905, Nanzheng Mansion
No. 580, Nanjingxi Road
SHANGHAI, 200041
Phone +86-21-5228 2233
Telefax +86-21-6267 7975

Beijing Office
Shengfu Mansion, Rm. 1830, No. 37,
Maizidian Road, Chaoyang District,
BEIJING, 100026
Phone +86-10-8527 6898
Telefax +86-10-8527 6899

COLOMBIA

Casa Sueca, S.A.
Calle 52 1N-74
CALI
Phone +57 -2- 682 0444
Telefax +57 -2- 683 1411

CROATIA

Lenze Antriebstechnik GmbH
Predstavništvo Zagreb
Ulica Grada Gospica 3
HR-1000 ZAGREB
Phone +385-1-2 49 80 56
Telefax +385-1-2 49 80 57

CZECH REPUBLIC

Lenze, s.r.o.
Central Trade Park D1
396 01 HUMPOLEC
Phone +420 565 507-111
Telefax +420 565 507-399

Büro Červený Kostelec:
17. listopadu 510
549 41 ČERVENÝ KOSTELEČ
Phone +420 491 467-111
Telefax +420 491 467-166

DENMARK *

Lenze A/S
Vallensbækvej 18A, 2605 BRØNDBY
Phone +45 / 46 96 66 66
Telefax +45 / 46 96 66 60
24 stunde service +45 / 40 93 04 11
Büro Jylland: Lenze A/S
Langhøjvej 1, 8381 TILST
Phone +45 / 46 96 66 66
Telefax +45 / 46 96 66 80

EGYPT

WADI Co. for technologies
and development
P.O.Box 209, new center Ramses
11794 CAIRO, Egypt
11 Syria St., Mohandessin
GIZA, Egypt
Phone +20 (2) 347 6842
Telefax +20 (2) 347 6843

ESTONIA

see FINLAND

FINLAND *

Lenze Drives
Rykmentintie 2 b
20810 TURKU
Phone +358 2 2748 180
Telefax +358 2 2748 189

FRANCE *

Lenze S.A.
Siège
ZI des Mardelles
44 Rue Blaise Pascal
93600 AULNAY-SOUS-BOIS

Services Commerciaux
Phone 0 825 086 036
Telefax 0 825 086 346

Centre de formation
E-Mail : semin.sidonie@lenze.fr

Questions générales / documentation
E-Mail : info@lenze.fr

Service Après-vente / assistance en ligne
Helpline 24/24 : 0 825 826 117
E-Mail : helpline@lenze.fr

Agences en France
Région France Nord :
ZI des Mardelles
44 Rue Blaise Pascal
93600 AULNAY-SOUS-BOIS
Nantes
44000 NANTES

Strasbourg
67870 GRIESHEIM près MOLSHEIM
Rouen
76500 ELBEUF

Région France Sud :
Parc Technologique
97, allée Alexandre Borodine
Immeuble le Douglas 2
69800 SAINT PRIEST

Toulouse
31400 TOULOUSE

Agen
47270 SAINT-PIERRE de CLAIRAC

GRÉECE

George P. Alexandris S.A.
12K. Mavromichali Str.
185 45 PIRAEUS
Phone +30 (0)210 / 41 11 84 15
Telefax +30 (0)210 / 4 11 81 71
4 12 70 58

183 Monastiriou Str.
546 27 THESSALONIKI
Phone +30 (0)310 / 5 56 65 04
Telefax +30 (0)310 / 5 11 8 15

HUNGARY *

Lenze Antriebstechnik
Handelsgesellschaft mbH
2040 BUDAÖRS
Gyár utca 2., P.O.Box 322.
Phone +36 (0)23 / 501-320
Telefax +36 (0)23 / 501-339

ICELAND

see DENMARK

INDIA

Lenze Mechatronics Pvt. Ltd.
Lenze Plot No. 46A, Sector-10
PCNTDA Industrial Area
Bhosari
PUNE - 411 026
Phone +91-20-66318100
Telefax +91-20-66318120



Kolkata Sales office
Block No. 81, 8th Floor
Circular Court, 8 A.J.C. Bose Road
KOLKATA - 700017
Phone +91-33-22893161
Telefax +91-33-22893162

New Delhi Sales office
Flat No - 101, Padma Tower - II
22, Rajendra Place
NEW DELHI - 110008
Phone +91-11-45062113/114
Telefax +91-11-45062315

INDONESIA

see MALAYSIA

IRAN

Tavan Rissan Co. Ltd.
P.O.Box. 19395-5177
No. 44, Habibi St., South Dastour St.,
Sadr EXP'Way, TEHRAN 19396
Phone +98 212 / 260 2655
260 67 66
260 92 99
Telefax +98 212 / 200 2883

ISRAEL *

Zeev Melcer LTD
P.O.B. 10011, HAIFA BAY 26110
36 Yosef Levi St., Kiriat Bialik
Phone +972 4 8757037
Telefax +972 4 8146109

ITALY *

Lenze Gerit S.r.l.
Viale Monza 338
20128 MILANO
Phone +39 02 / 270 98.1
Telefax +39 02 / 270 98 290

JAPAN *

Miki Pulley Co., Ltd.
1-39-7 Komatsubara, Zama-city
KANAGAWA 228-8577
Phone +81 (0)462/581661
Telefax +81 (0)462/581704

LATVIA

see LITHUANIA

LEBANON

I. Network Automation s.a.l.
Ground floor - United insurance building
Facing Mercedes Show room
Dora - High Way
BEIRUT-METEN
P.O.Box 835 - Jounieh - Lebanon
Phone +961-1-249562
Telefax +961-1-249563

LITHUANIA

Lenze UAB
Breslaujos g.3, 44403 KAUNAS
Phone +370 37 407174
Telefax +370 37 407175

LUXEMBOURG *

see BELGIUM

MACEDONIA

Lenze Antriebsstechnik GmbH
Pretstavnistvo Skopje
ul. Nikola Rusinski 3/A/2, 1000 SKOPJE
Phone +389 2 30 90 090
Telefax +389 2 30 90 091

MALAYSIA

Lenze S.E.A. Sdn Bhd
No. 28 Jalan PJU 3/47
Sunway Damansara, Technology Park
47810 PETALING JAYA
SELANGOR DARUL EHSAN
Phone +60 3 7803 1428
Telefax +60 3 7806 3728

MAURITIUS

Automation & Controls Engineering Ltd
3, Royal Road, Le Hochet, Terre Rouge
MAURITIUS
Phone +230 248 8211
Telefax +230 248 8968

MEXICO

Automatización y Control
de Energía S.A. de C.V.
Av. 2 No. 89 Esq Calle 13
Col. San Pedro de los Pinos
C.P. 03800 MEXICO D.F.
Phone +52 (55) 2636-3540
Telefax +52 (55) 2636-3541

MOROCCO

GUORFET G.T.D.R
Automatisation Industrielle
Bd Chefchaouni Route 110 km, 11.500
No. 353-Ain-Sabaâ
CASABLANCA
Phone +212/22-35 70 78
Telefax +212/22-35 71 04

NETHERLANDS *

Lenze B.V., Postbus 31 01
5203 DC 'S-HERTOGENBOSCH
Ploegweg 15
5232 BR 'S-HERTOGENBOSCH
Phone +31 (0)73 / 64 56 50 0
Telefax +31 (0)73 / 64 56 51 0

NEW ZEALAND *

Tranz Corporation
343 Church Street
P.O. Box 12-320, Penrose
AUCKLAND
Phone +64 (0)9 / 63 45 51 1
Telefax +64 (0)9 / 63 45 51 8

NORWAY *

Dtc- Lenze as
Stallbakken 5, 2005 RAEILINGEN
Phone +47 / 64 80 25 10
Telefax +47 / 64 80 25 11

PHILIPPINES

see MALAYSIA

POLAND

Lenze-Rotiv Sp. z o.o.
ul. Rożdżenieckiego 188b
40-203 KATOWICE
Phone +48 (0)32 / 2 03 97 73
Telefax +48 (0)32 / 7 81 01 80
Lenze Systemy Automatyki Sp. z o.o.
Ul. Rydygiera 47
87-100 TORUŃ
Phone +48 (0)56 / 6 58 28 00
6 45 34 60
6 45 35 70
Telefax +48 (0)56 / 6 45 33 56

PORTUGAL *

Costa Leal el Victor
Electronica-Pneumatica, Lda.
Rua Prof. Augusto Lessa, 269,
Apart. 52053
4202-801 PORTO
Phone +351-22 / 5 03 85 20
Telefax +351-22 / 5 02 40 05

ROMANIA

see AUSTRIA

RUSSIA

Inteldrive
1-ja Buhvostova Street 12/11
Korpus 17-18 Office 213
MOSCOW 107076
Phone +7 495 748 7827
Fax/Tel. +7 495 963 9686

SERBIA-MONTENEGRO

see MACEDONIA

SINGAPORE *

see MALAYSIA

SLOVAC REPUBLIC

ECS Sluzby spol. s.r.o.
Staromlynska 29
82106 BRATISLAVA
Phone +421 2 45 25 96 06
+421 2 45 64 31 47
+421 2 45 64 31 48
Telefax +421 2 45 25 96 06

SLOVENIA

LENZE GmbH, Asten, Avstrija
Podružnica Celje
Kidričeva 24
3000 CELJE
Phone +386 03 426 46 40
Telefax +386 03 426 46 50

SOUTH AFRICA *

S.A. Power Services (Pty) Ltd.
Unit 14, Meadowbrook Business Estates
Jacaranda Ave, Olivedale
Randburg 2158, P.O.Box 1137
RANDBURG 2125
Phone +27(11) 462-8810
Telefax +27(11) 704-5775

SOUTH KOREA *

Hankuk Mechatro Ltd.
Room# 1409
Samhwan officetel 830-295
Beomil-dong, Dong-Gu
PUSAN
Phone +82 (0)51-635-6663
Telefax +82 (0)51-635-6632

SPAIN *

Lenze Transmisiones, S.A. (Headquarter)
Milà i Fontanals, 135-139
08205 SABADELL
Barcelona
Phone +34 937 207 680
Telefax +34 937 120 215

Lenze Delegación Bilbao
Pl. Ibarra Barri. Ed. METRO 2º-E
48940 LEJONA
Vizcaya
Phone +34 944 630 510/ 507
Telefax +34 944 314 196

Lenze Delegación Levante
Cullera, 73 - 4ºD
46035 BENIMAMET
Valencia
Phone +34 963 905 220/335
Telefax +34 963 900 647

Lenze Delegación Madrid
Arturo Soria, 187 - Of. 8
28043 MADRID
Phone +34 915 103 341
Telefax +34 915 102 061

SWEDEN *

Lenze Transmissioner AB
P.O.Box 10 74, Attorpsgatan, Tornby Ind.
58110 LINKÖPING
Phone +46 (0)13 / 35 58 00
Telefax +46 (0)13 / 10 36 23

SWITZERLAND *

Lenze Bachofen AG
Ackerstrasse 45
8610 USTER
Phone +41 (0) 43 399 14 14
Telefax +41 (0) 43 399 14 24

Vente Suisse Romande:
Route de Prilly 25
1023 CRISSIER
Phone +41 (0)21 / 63 72 19 0
Telefax +41 (0)21 / 63 72 19 9

SYRIA

Zahabi Co.
8/5 Shouhadaa Street, P.O.Box 8262
ALEPPO-SYRIA
Phone +963 21 21 22 23 5
Telefax +963 21 21 22 23 7

TAIWAN *

Lenze Taiwan Representative Office
Room 1101, 11 Fl. No. 136, Sec. 3,
Ren-Ai-Rd., Da-An District
TAIPEI City
Taiwan 241, R.O.C.
Phone +886 / (0)2-2705-2161
Telefax +886 / (0)2-2705-6906

ACE Pillar Co., Ltd.
2F, No. 7, Lane 83, Sec. 1
Kuang-Fu Road, San-Chung City
TAIPEI Sheing
Phone +886 / (0)2-2995-8400
Telefax +886 / (0)2-2995-3466

THAILAND

see MALAYSIA

TUNESIA

AMF Industrielle Sarl
Route de Gremda - Km 0,2
Immeuble El Madina,
Centre Bloc B - 5 ème - appt 52
3002 SFAX
Phone +216 74 403 514
Telefax +216 74 402 516

TURKEY

LSE Elektrik
Elektronik Makina
Otomasyon Mühendislik
Sanayi ve Ticaret Ltd. Şti
Atatürk mah. Cumhuriyet cad.
Yurt sok. No: 7
ÜMRANIYE/İSTANBUL
Phone +90 (0)216 / 316 5138 pbx
Telefax +90 (0)216 / 443 4277

UKRAINE

SV Altera, Ltd.
Lepse ave., 4
KIEV, 03067
Phone +38 044 496 18 88
Telefax +38 044 496 18-18

UNITED ARAB EMIRATES

LPT (FZC)
Executive Suite X4-37
P.O. Box: 9304, SAIF ZONE
SHARJAH AIRPORT INTERNATIONAL
FREE ZONE (SAIF ZONE)
Phone +971 6 5573205
Telefax +971 6 5573206

UNITED KINGDOM/EIRE *

Lenze Ltd.
Caxton Road
BEDFORD MK 41 OHT
Phone +44 (0)1234 / 32 13 21
Telefax +44 (0)1234 / 26 18 15

USA *

AC Technology Corp.
630 Douglas Street
UXBRIDGE, MA 01569
Phone +1 508 / 278-9100
Telefax +1 508 / 278-7873

Lenze Corporation
1730 East Logan Avenue
EMPORIA, KS 66 801
Phone +1 620 / 343-8401
+1 888 / 269-2381
Telefax +1 620 / 342-2595
+1 800 / 469-0931

Lenze DETO Drive Systems USA, LLC
5912 Sterling Drive
HOWELL, MI 48843
Phone +1 517 / 586-4057
Telefax +1 517 / 586-4058

VIETNAM

see MALAYSIA

* Countries connected to the free expert helpline 008000 24 hours (008000 24 46877)

It's good to know | why we are there for you



"Our customers come first. Customer satisfaction is what motivates us. By thinking in terms of how we can add value for our customers we can increase productivity through reliability."



"The world is our marketplace. We develop and manufacture internationally. Wherever you are in the world, we are nearby."



"We will provide you with exactly what you need – perfectly co-ordinated products and solutions with the right functions for your machines and installations. That is what we mean by 'quality'."

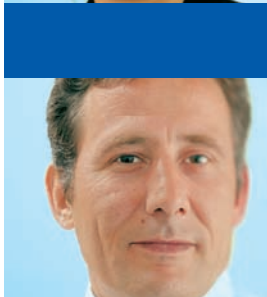

"Take advantage of our wealth of expertise. For more than 50 years we have been gathering experience in various fields and implementing it consistently and rigorously in our products, motion functions and preprepared solutions for industry."



"We identify with your targets and strive towards a long-term partnership which benefits both sides. Our competent support and consultation process means that we can provide you with tailor-made solutions. We are there for you and can offer assistance in all of the key processes."

You can rely on our service. Expert advice is available 24 hours a day, 365 days a year, in more than 30 countries via our international helpline: 008000 24 Hours (008000 2446877).

www.Lenze.com

13191282