

# Rightangle

# Gears

Cat.: CT-VFM-BS-HM015

**Worm gearboxes**

Riduttori a vite senza fine  
0.06 ÷ 7.5 kW

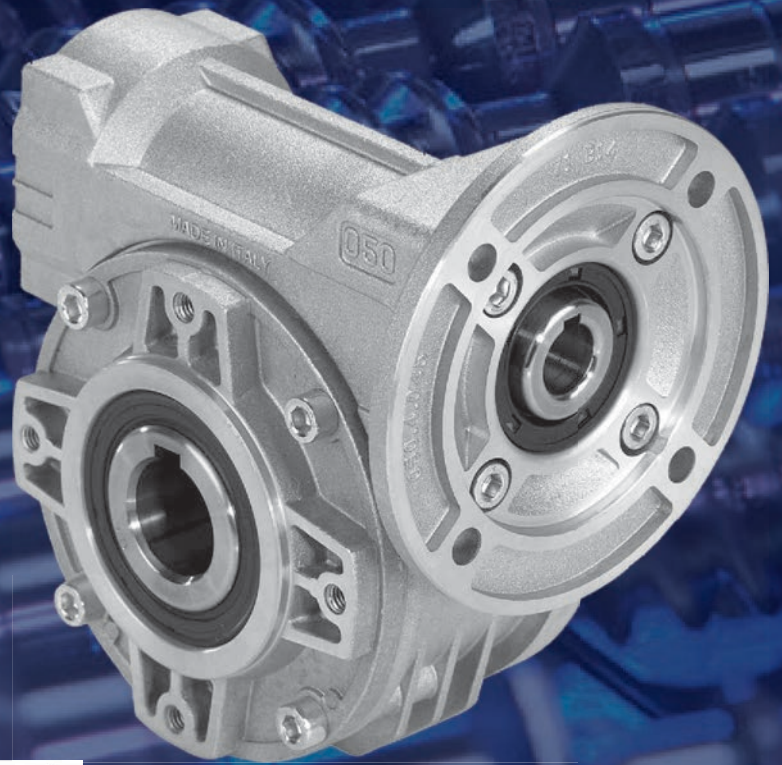

Made in Italy



Dossier according  
to 94/9/EG 8. b ii  
stored



# HYDRO · MEC

# Worm gearboxes

## A modular and compact product

### Single-piece aluminum alloy housing

Is vacuum impregnated (MIL-STD 276) for protection and sealing. No secondary finish required but readily accepts paint. Combines light weight with high tensile strength. Precision machined for alignment of bearings and gearing.

### Single piece alloy steel input shaft and worm shaft.

High helix angle worm is case-hardened (Rc 58-60), ground, teeth are profiled and radiused, for noise reduction and enhanced efficiency.

### Oversized bearings

Support positively-retained, high speed shaft for higher shock load capacity - ideal for frequent starting and reversing application. Premium, Nitrile® high temperature seals each end.

### Bronze alloy worm gears.

Is centrifugally cast onto an iron hub for maximum strength and superior life.

### Over-size bearing

For radial load capability and maximum hollow output shaft diameter.

### Impregnated and machined bearing caps

With exterior machined surfaces enable a variety of mounting accessories. Extra-deep thread engagement provided for greater support strength. Zinc plated hardware.

### Flange

Fully modular to IEC and compact integrated motor. NEMA C flange.

### Premium, high temperature

Nitrile® output seals

### Standard hollow output shaft mounting

Reduces total drive envelope size, weight and cost. Single and double solid output shaft is available.

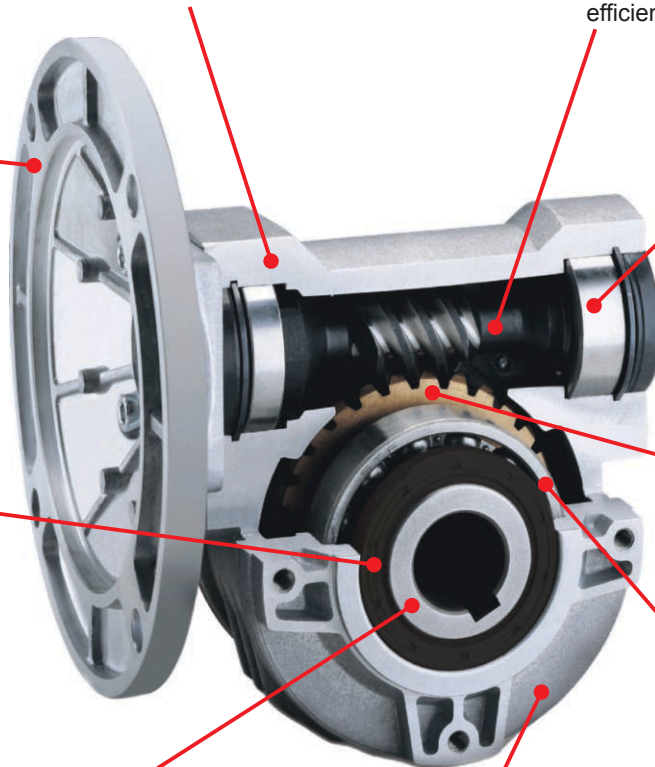

### Vent Free Design.

No breather or vents to leak! Factory lubricated for life with synthetic, semi-fluid gear lubricant with an operating range of -15°C to 130°C.

oil free



vent free



# Specific type datasheet on page...

On page / A pagina / Auf Seite / À la page / En la página

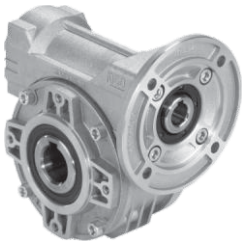

Types / Tipi / Tipen / Types / Tipos →

1-5	1-7	1-9	1-11	1-13	1-15	1-17
030 21Nm	045 41Nm	050 72Nm	063 147Nm	63A 191Nm	085 347Nm	110 651Nm

On page / A pagina / Auf Seite / À la page / En la página

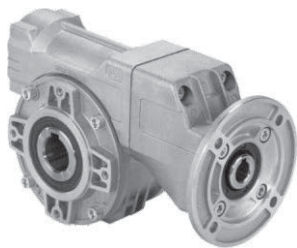

Types / Tipi / Tipen / Types / Tipos →

1-19	1-21	1-23	1-25	1-27	1-29
P45 55Nm	P50 88Nm	P63 187Nm	P6A 218Nm	P85 440Nm	P10 803Nm

On page / A pagina / Auf Seite / À la page / En la página

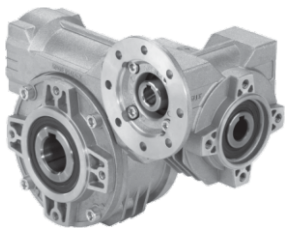

Types / Tipi / Tipen / Types / Tipos →

1-31	1-33	1-35	1-37	1-39	1-41	1-43	1-45	1-47
303 35Nm	453 69Nm	503 109Nm	633 230Nm	634 265Nm	6A3 290Nm	6A4 304Nm	854 518Nm	115 978Nm

Type - Tipo - Typ  
Type - Tipo

Size - Grandezza  
Größe - Taille  
Tamaño

Mounting - Montaggio - Montage Fixation  
Fixation - Tipo de montaje

**P**

**045**

**PA**

**Worm gearboxes**

Riduttori a vite senza fine  
Schneckengetriebe  
Reducteurs a vis sans fin  
Reductores de corona sin fin

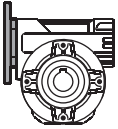

**P**

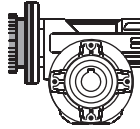

**M**

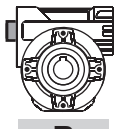

**B**

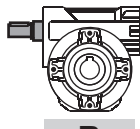

**R**

**030  
045  
050  
063  
63A  
085  
110**

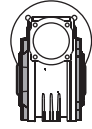

**FB**

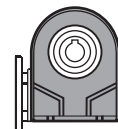

**PB**

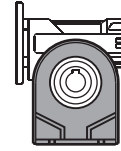

**PA**

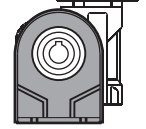

**PV**

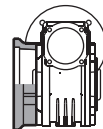

**FC**

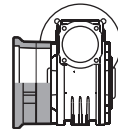

**FL**

**F1  
F2  
F3  
F4**

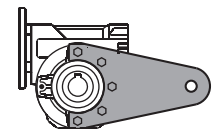

**BR**

**Worm gearboxes with primary reduction**

Riduttori a vite senza fine con precoppia  
Schneckengetriebe mit Stirradstufe am Eintrieb  
Reducteurs a vis sans fin avec pré-réduction  
Reductores corona sin fin con prereducora de engranajes

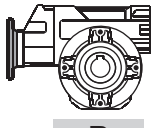

**P**

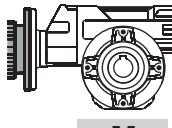

**M**

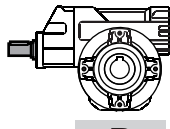

**R**

**P45  
P50  
P63  
P6A  
P85  
P10**

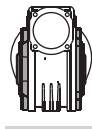

**FB**

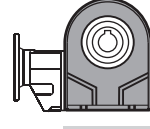

**PB**

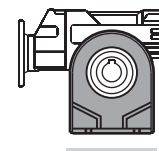

**PA**

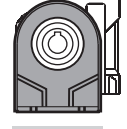

**PV**

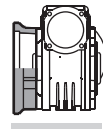

**FC**

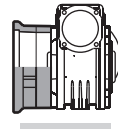

**FL**

**F1  
F2  
F3  
F4**

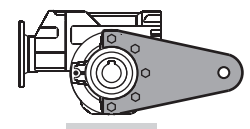

**BR**

**Combined worm gearboxes**

Riduttori a vite senza fine combinati  
Schneckengetriebekombinationen  
Reducteurs a double train de vis sans fin  
Reductores combinados corona sin fin

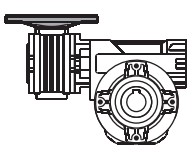

**P**

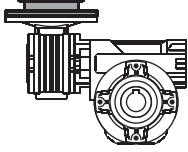

**M**

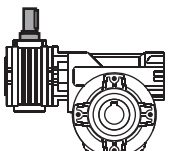

**R**

**303  
453  
503  
633  
634  
6A3  
6A4  
854  
115**

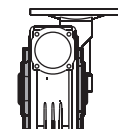

**FB**

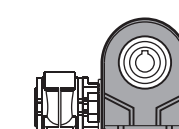

**PB**

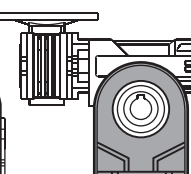

**PA**

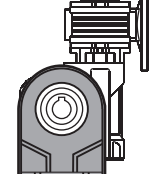

**PV**

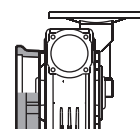

**FC**

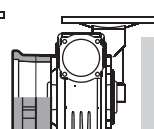

**FL**

**F1  
F2  
F3  
F4**

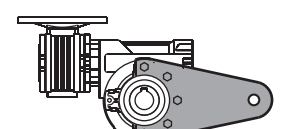



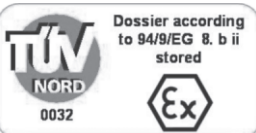



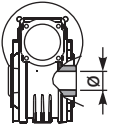
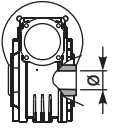
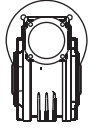
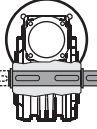
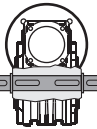
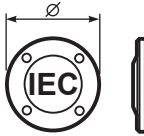

**BR**

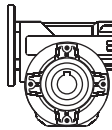

On request we can deliver our products according to the ATEX  
A richiesta possiamo fornire i nostri prodotti secondo le normative ATEX  
Auf Anfrage können wir unsere Produkte den Richtlinien ATEX entsprechend liefern  
Sur demande nos produits peuvent se conformer à la réglementation ATEX  
A pedido, se pueden enviar nuestros productos de acuerdo con las normas ATEX.

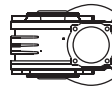
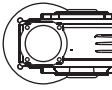
CODIFICA / HOW TO ORDER / TYPENBEZEICHNUNGEN / CODIFICATION / CODIFICACIÓN

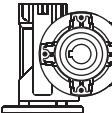
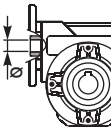
Ratio Rapporto Untersetzung Reduction Relación	Hub Mozzo corona Hohlwelle Arbre creux Nucleo corona	Output shaft Albero lento Abtriebswelle Arbre de sortie Eje solida	Motor size Grandezza motore Motor Grösse Grandeur moteur Tamaño motor	Terminal box position Posizione morsettiere Klemmkastenlage Position boîte a bornes Posición caja de bornes	Mounting position Posizione montaggio Einbaulage Position de montage Position de montaje	Reduced Input bore Foro entrata ridotto Reduzierte Eingangshohlwelle Trou d'entree de diametre reduit Eje hueco de entrada reducido	Mountin position Esecuzione montaggio Einbaulage Exécution de montage Posición de montaje
<b>10</b>	<b>C</b>	<b>∅</b>	<b>-Q</b>	<b>B</b>	<b>B3</b>	<b>-</b>	<b>---</b>
See technical data table Vedi tabella dati tecnici. Technisches Datenblatt beachten Voir tableau données techniques Ver tabla datos técnicos	 <b>C</b> STANDARD 030 ⇨ ∅14 045 ⇨ ∅18 050 ⇨ ∅25 063 ⇨ ∅25 63A ⇨ ∅28 085 ⇨ ∅35 110 ⇨ ∅42  <b>I</b> Stainless steel hub Mozzo in acciaio Inox Edelstahlhohlwelle Moyeu en acier Inox Nucleo corona de acero Inox  Special series Serie Speciale  <b>S</b> 045 ⇨ ∅19 050 ⇨ ∅24  <b>X</b> Stainless steel hub Mozzo in acciaio Inox Edelstahlhohlwelle Moyeu en acier Inox Nucleo corona de acero Inox   <b>U</b> INCH 045 ⇨ ∅0.750" 050 ⇨ ∅1.000" 063 ⇨ ∅1.125" 085 ⇨ ∅1.500"	 <b>∅</b>   <b>S</b>   <b>D</b>	 <b>-M</b> without flange Senza flangia  <b>B5</b> <b>-A=56</b> (∅120) <b>-B=63</b> (∅140) <b>-C=71</b> (∅160) <b>-D=80</b> (∅200) <b>-E=90</b> (∅200) <b>-F=100+112</b> (∅250) <b>-G=132</b> (∅300)  <b>B14</b> <b>-O=56</b> (∅80) <b>-P=63</b> (∅90) <b>-Q=71</b> (∅105) <b>-R=80</b> (∅120) <b>-T=90</b> (∅140) <b>-U=100+112</b> (∅160) <b>-V=132</b> (∅200)  <b>-0=Type R</b> <b>-S=Type R</b> S series	 <b>A</b>   <b>B</b> STANDARD   <b>C</b>   <b>D</b>	 <b>B3</b>   <b>B8</b>   <b>B6</b>   <b>B7</b>   <b>V5</b>   <b>V6</b>	 <b>-</b> Nothing indication standard bore  Nessuna indicazione foro standard  <b>P</b> Input bore reduced one size  Foro entrata ridotto di una misura  Ex. Input Flange 71 B14 Standard ∅14 Reduced ∅11  <b>Q</b> Input bore reduced two sizes  Due grandezze ridutte foro entrata  Ex. Input Flange 71 B14 Standard ∅14 Reduced ∅9	<b>Only for combined units</b> See technical data table  Solo per i riduttori combinati Vedi tabella dati tecnici.  Ausführungen für Getriebekombinationen it  Uniquement pour combinés. Voir tableau données techniques  Sólo para combinados ver tabla datos técnicos

1

**POTENZA RICHIESTA / REQUIRED POWER / ERFORDERLICHE LEISTUNG / PUISSANCE NECESSAIRE / POTENCIA NECESARIA**

Lifting / sollevamento / hubantriebe / levage / elevación

$$P \text{ [KW]} = \frac{M \text{ [Kg]} \cdot g \text{ [9.81]} \cdot v \text{ [m / s]}}{1000}$$

Rotation / rotazione / drehung / rotation / rotacion

$$P \text{ [KW]} = \frac{M \text{ [Nm]} \cdot n \text{ [rpm]}}{9550}$$

Linear movement / traslazione / linearbewegung / translation / translacion

$$P \text{ [KW]} = \frac{F \text{ [N]} \cdot v \text{ [m / s]}}{1000}$$

**TORQUE / COPPIA / DREHMOMENT / COUPLE / PAR**

$$M \text{ [Nm]} = \frac{9550 \cdot P \text{ [KW]}}{n \text{ [rpm]}}$$

$$M \text{ [lb in]} = \frac{63030 \cdot P \text{ [HP]}}{n \text{ [rpm]}}$$

**RADIAL LOADS / CARICHI RADIALI / RADIALE - UND AXIALLASTEN / CHARGES RADIALES / CARGA RADIAL Y AXIAL**

- Radial load generated by external transmissions keyed onto input and/or output shafts.
- Forza radiale generata da organi di trasmissione calettati sugli alberi di ingresso e/o uscita.
- Belastungen der Antriebs- bzw. Abtriebswellen durch von aussen eingebrachte Radiallasten.
- Charge radiale générée par la transmissions calés sur les entrées et / ou des arbres de sortie
- Cargas radiales, generada por transmisiones externas, aplicadas sobre los ejes de entrada y/o salida

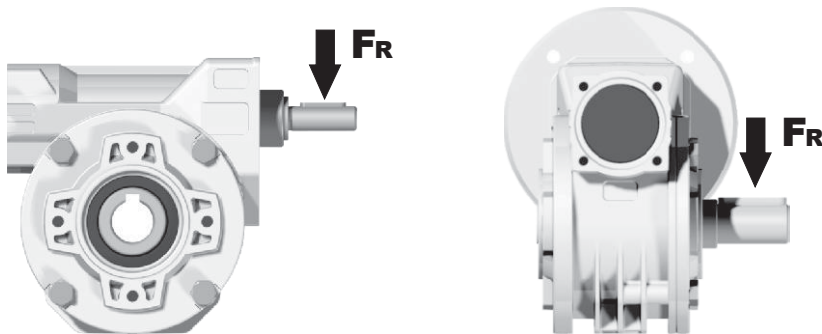

$F_R \text{ [N]} = \frac{M \text{ [Nm]} \cdot 2000}{d \text{ [mm]}} \cdot f_k$		$F_R \text{ [N]} = \frac{M \text{ [lb in]} \cdot 8.9}{d \text{ [in]}} \cdot f_k$	
<b>M</b>	Momento torcente / Output torque / Abtriebsdrehmoment / Couple / Par torsion		
<b>d</b>	Diametro primitivo / Diam. of driving element / Durchmesser der Abtriebseinheit / Diamètre primitif / Diámetro primitivo		
<b>f<sub>k</sub></b>	Coefficiente di trasformazione / Factor / Faktor / Coefficient de transmission / Coeficiente de transmisión <b>1.15</b> Ingranaggi / Gearwheels / Zahnrad / Engrenage / Engranaje <b>1.25</b> Catena / Chain sprockets / Antriebskette / Chaîne / Cadena <b>1.75</b> Cinghia Trapezoidale / Narrow v-belt pulley / Keilriemen / Courroie trap. / Correa trapezoidal <b>2.50</b> Cinghia piatta / Flat-belt pulley / Flachzahnriem. / Courroie crantée / Correa plana		

- If your application requires higher radial loads, contact our technical office. Higher load may be possible.
- Nel caso la vostra applicazione richieda carichi radiali superiori consultare il nostro ufficio tecnico, valori maggiori possono essere accettati.
- Wenn Ihre Anwendung höhere Radialbelastungen erfordert, so wenden Sie sich bitte an unser technischen Büro.
- Si votre application demande des charges radiales supérieures, s'adresser à notre bureau technique.
- En el caso en que una aplicación exija una carga radial superior a la especificada en el catálogo, consultar a nuestra oficinas técnica.

How to select a gearbox / Come selezionare un riduttore / Wie wählt man ein Getriebe  
Comment sélectionner un réducteur / Cómo seleccionar un reductor

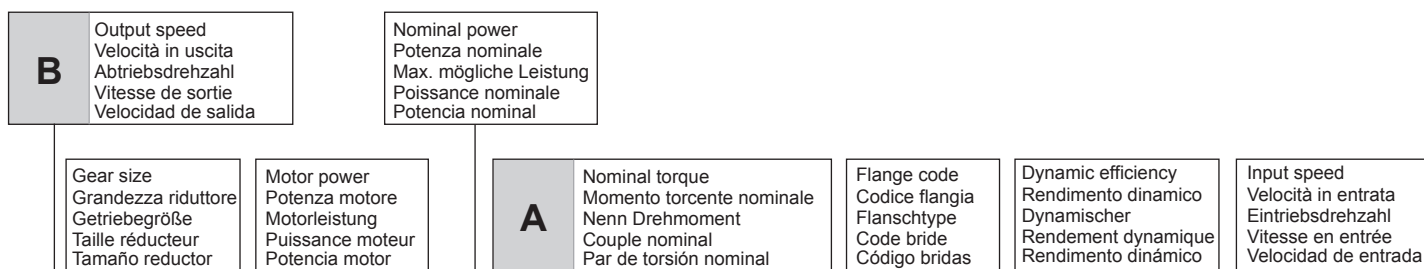

**045** Rightangle - Gear  
**41Nm**

Rating - Aluminum WORM GEARBOXES



**QUICK SELECTION / Selezione veloce** input speed ( $n_1$ ) = 1400 min<sup>-1</sup>

Output Speed $n_2$ [min <sup>-1</sup> ]	Ratio $i$	Motor power $P_{1M}$ [kW]	Output torque $M_{2M}$ [Nm]	Service factor f.s.	Nominal power $P_{1R}$ [kW]	Nominal torque $M_{2R}$ [Nm]	Available B5 motor flanges		Available B14 motor flanges			Dynamic efficiency RD	Tooth Module [mm]	Ratios code
							-B	-C	-O	-P	-Q			
200	7	0.37	14	2.2	0.80	30	B		B-C	B-C		80	2.2	01
140	10	0.37	20	1.5	0.57	30	B		B-C	B-C		79	2.2	02
100	14	0.37	27	1.1	0.41	30	B		B-C	B-C		77	2.4	03



**fs**

Type of load and starts per hour Tipo di carico e avviamenti per ora		Oper. hours per day Ore di funz. giorn.		
		<2 h	2 - 8 h	8 - 16 h
Continuous or intermittent appl. with start / hour Applicazione cont. o interm. con n.ro operazioni/ora	Uniform / Uniforme	0.9	1	1.25
	Moderate / Moderato	1	1.25	1.5
	Heavy / Forte	1.25	1.5	1.75
Intermittent application with start / hour Applicazione intermittente con n.ro operazioni/ora	Uniform / Uniforme	1.25	1.5	1.75
	Moderate / Moderato	1.5	1.75	2
	Heavy / Forte	1.75	2	2.25

**D**

	Motor flange available Flange disponibili Erhältliche Motorflansche Brides disponibles Bridas disponibles	
<b>B)</b>	Mounting with reduction ring Montaggio con boccia di riduzione Reduzierhülsen Montage avec douille de réduction Montaje con casquillo de reducción	
<b>C)</b>	Motor flangeholes position/terminal box position Posizione fori flangia/basetta motore Bohrungsposition am Motorflansch/-sockel Position trous bride/barrette à bornes moteur Posición agujeros brida / base motor	
<b>B)</b>	Available without reduction bushes Disponibile anche senza boccia Auch ohne Reduzierbuchse verfügbar Disponible aussi sans douille de réduction Disponible tambien sin casquillo	

<b>A</b>	Select required torque (according to service factor)	Seleziona la coppia desiderata (comprensiva del fattore di servizio)	Max. Drehmoment in Bezug zum Betriebsfaktor	Sélectionner le couple souhaité (comprenant le facteur de service)	Seleccionar el par deseado (incluyendo el factor de servicio)
<b>B</b>	Select output speed	Seleziona la velocità in uscita	Ausgewählte Abtriebsdrehzahl	Sélectionner la vitesse de sortie	Seleccionar la velocidad de salida
<b>C</b>	On the same line of selected geared motor, you can find the gear ratio	Sulla riga corrispondente alla motorizzazione prescelta si può rilevare il rapporto di riduzione	Auf der gleichen Linie wie die ausgewählte Motorleistung steht auch die Getriebeuntersetzung	Sur la ligne correspondante à la motorisation pré-choisie on peut relever le rapport de réduction	En la línea correspondiente al motor preseleccionado es posible encontrar la relación de reducción
<b>D</b>	Select motor flange available (if requested)	Scegli la flangia disponibile (se richiesta)	Erhältliche Motorflansche (auf Anfrage)	Choisir la bride disponible (si elle est demandée)	Seleccionar la brida disponible (sobre pedido)



#### QUICK SELECTION / Selezione veloce

input speed ( $n_1$ ) = 1400 min<sup>-1</sup>

Output Speed $n_2$ [min <sup>-1</sup> ]	Ratio $i$	Motor power $P_{1M}$ [kW]	Output torque $M_{2M}$ [Nm]	Service factor f.s.	Nominal power $P_{1R}$ [kW]	Nominal torque $M_{2R}$ [Nm]	Available B5 motor flanges		Available B14 motor flanges		Dynamic efficiency <b>RD</b>	Tooth Module  [mm]	 Ratios code
							-A	-B	-O	-P			
							56	63	56	63			
280	<b>5</b>	0.18	5	3.3	<b>0.60</b>	17	B		B-C		82	1.26	09
200	<b>7</b>	0.18	7	2.4	<b>0.44</b>	17	B		B-C		80	1.44	01
140	<b>10</b>	0.18	10	1.8	<b>0.32</b>	17	B		B-C		78	1.44	02
93	<b>15</b>	0.18	13	1.4	<b>0.25</b>	19	B		B-C		73	1.44	03
70	<b>20</b>	0.18	17	1.1	<b>0.20</b>	19	B		B-C		70	1.09	04
47	<b>30</b>	0.12	15	1.4	<b>0.17</b>	21	B		B-C		62	1.44	05
35	<b>40</b>	0.12	19	1.1	<b>0.13</b>	20	B		B-C		57	1.09	06
23	<b>61</b>	0.09	19	1.1	<b>0.10</b>	20	B		B-C		50	0.72	07
17.5	<b>80</b>	0.09	16	1.0	<b>0.06</b>	16	B		B-C		48	0.56	08

**A) Motor Flanges Available**  
Flange Motore Disponibili

**B) Supplied with Reduction Bushing**  
Fornito con Bussola di Riduzione

**B) Available on Request without reduction bushing**  
Disponibile a Richiesta senza Bussola di Riduzione

**C) Motor Flange Holes Position**  
Posizione Fori Flangia Motore

**EN** Unit **030** is supplied with synthetic oil, providing "long life" lubrication. For mounting position V5-V6 please contact us. See table 1 for lubrication and recommended quantity. In table 2 please see possible radial loads and axial loads on the gearbox.

**I** Il riduttore tipo **030** viene fornito lubrificato a vita con olio sintetico. Per posizioni V5-V6 contattare il ns. servizio tecnico. Vedi tab.1 per oli e quantità consigliati. In tab.2 sono presenti i carichi radiali e assiali applicabili al riduttore.

**D** Für die Lebensdauerschmierung ist das Getriebe der Größe **030** mit synthetischem Öl befüllt. Bei Einbaulage V5 oder V6 bitten wir um Rücksprache. In Tabelle 1 ist die Schmiermenge und das empfohlene Schmiermittel angegeben. In Tabelle 2 sind die zulässigen Radial- und Axialbelastungen des Getriebes aufgeführt.

**F** Le réducteur de type **030** est fourni lubrifié à vie avec de l'huile synthétique. Concernant les positions V5.V6, contactez notre service d'assistance technique. Voir tableau 1 concernant les huiles et les quantités conseillées. Les charges radiales et axiales applicables au réducteur sont précisées dans le tableau 2.

**E** El reductor tamaño **030** se suministra, lubricado de por vida con aceite sintético. Para las posiciones V5 y V6 contactar con nuestro servicio técnico. Ver tabla 1, para cantidades y aceites recomendados. En la tabla 2, se encuentran las cargas radiales y axiales admitidas por el reductor.

#### LUBRICATION 030 Oil Quantity 0.03 Lt.

**AGIP** Telium VSF 320

**SHELL** Omala S4 WE 320

For all details on lubrication and plugs check our website **tab. 1**  
Per maggiori dettagli su lubrificazione e tappi olio vedi il nostro sito web

#### RADIAL AND AXIAL LOADS

##### Output shaft

Albero di uscita

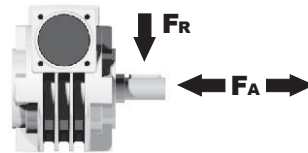

$n_2$ [min <sup>-1</sup> ]	FA [N]	FR [N]
200	120	600
150	140	700
100	160	800
75	180	900
50	200	1000
25	250	1250
15	280	1400

##### Input shaft

albero in entrata

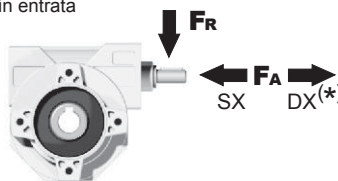

$n_1$ [min <sup>-1</sup> ]	FA [N]	FR [N]
1400	20	100

**\*Strong axial loads in the DX direction are not allowed.**  
Non sono consentiti forti carichi assiali con direzione DX

**tab. 2**



**P030FB...** Basic wormbox  
Riduttore base

Gearbox weight  
peso riduttore **1.05 kg**

M. flanges	Kit code	øF	A
<b>56B5</b>	K030.4.041	120	61.5
<b>63B5</b>	K030.4.042	140	62.5
<b>56B14</b>	K030.4.046	80	61.5
<b>63B14</b>	K030.4.045	90	62.5

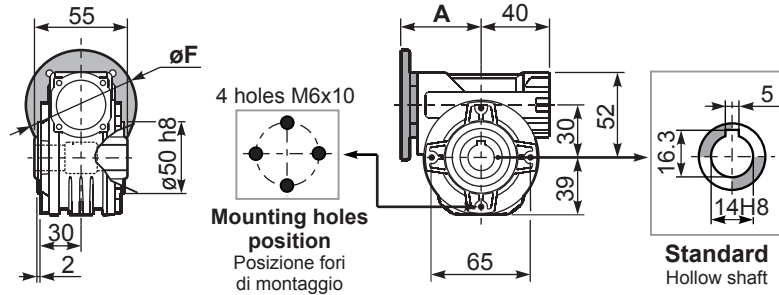

**P030PA...** Feet  
Piedini

**P030PB...** Feet  
Piedini

**P030PV...** Feet  
Piedini

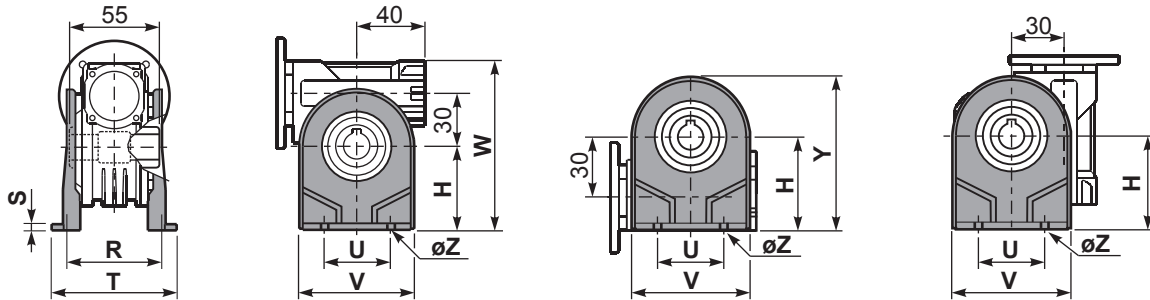

	H	R	S	T	U	V	Y	W	øZ	kit code
type B	55	66	3	87	50	78	94	107	ø6.5	K030.9.022
type S	52	66	3	87	52	90	91	104	ø6.5	KS030.9.023

**P030FC...** Output flange  
Flangia uscita

**P030BR...** Reaction arm  
Braccio di reazione

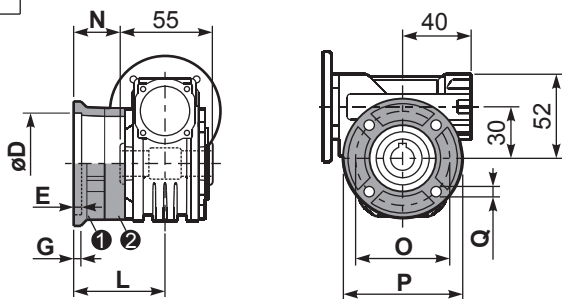

type B	øD	E	G	L	N	O	P	Q	kit code
<b>FC</b>	50 <sup>+0.15</sup> / <sub>+0.05</sub>	6	6	50.5	23	68	80	7	1 K030.9.010 2 -
<b>FL</b>	60 <sup>+0.15</sup> / <sub>+0.05</sub>	6	6	55.5	28	87	110	8.5	1 K045.9.010 2 -

  

type S	øD	E	G	L	N	O	P	Q	kit code
<b>F1</b>	40 <sup>+0.15</sup> / <sub>+0.10</sub>	3.5	5.5	49	21.5	56	80	6.5	1 KS030.9.012 2 -

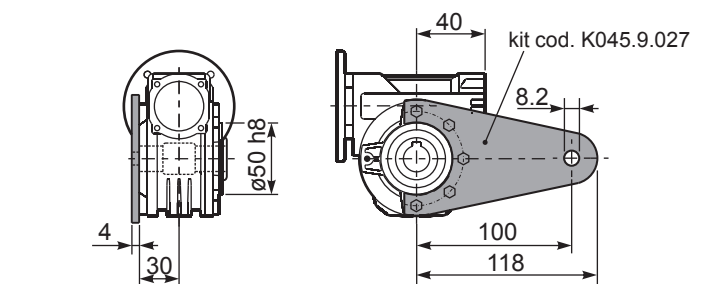

**P030.....S...** Single Shaft  
Albero lento semplice

**P030.....D...** Double Shaft  
Albero lento bisp.

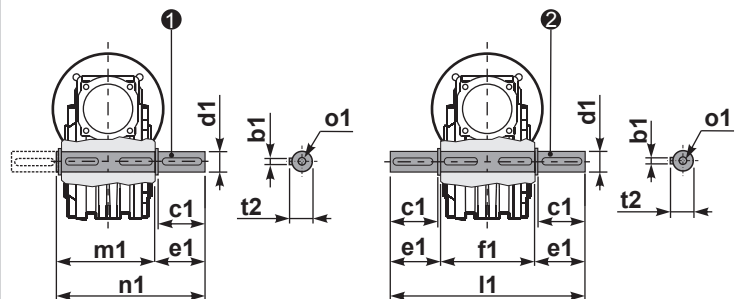

1 kit cod. K030.5.028 type B      2 kit cod. K030.5.029 type B

**R030FB...** Input shaft  
Albero in entrata

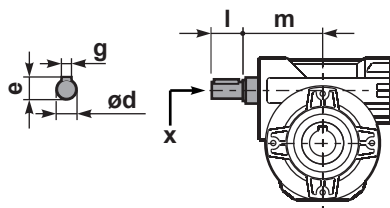

	ød	e	g	l	m	x	kit code
type B	9 h6	10.2	3	20	58	-	K030.5.006 PAM63
type S	-	-	-	-	-	-	-

	b1	c1	d1	e1	f1	l1	m1	n1	t2	o1
type B	5	25	14 <sup>-0.005</sup> / <sub>-0.020</sub>	35.5	55	126	59	94.5	16	M5x14
type S	-	-	-	-	-	-	-	-	-	-



#### QUICK SELECTION / Selezione veloce

input speed ( $n_1$ ) = 1400 min<sup>-1</sup>

Output Speed $n_2$ [min <sup>-1</sup> ]	Ratio $i$	Motor power $P_{1M}$ [kW]	Output torque $M_{2M}$ [Nm]	Service factor f.s.	Nominal power $P_{1R}$ [kW]	Nominal torque $M_{2R}$ [Nm]	Available B5 motor flanges		Available B14 motor flanges			Dynamic efficiency <b>RD</b>	Tooth Module  [mm]	Ratios code 
							-B	-C	-O	-P	-Q			
							63	71	56	63	71			
200	<b>7</b>	0.37	14	2.2	<b>0.80</b>	<b>30</b>	<b>B</b>		B-C	B-C		80	2.2	01
140	<b>10</b>	0.37	20	1.5	<b>0.57</b>	<b>30</b>	<b>B</b>		B-C	B-C		79	2.2	02
100	<b>14</b>	0.37	27	1.1	<b>0.41</b>	<b>30</b>	<b>B</b>		B-C	B-C		77	2.4	03
67	<b>21</b>	0.37	36	1.2	<b>0.43</b>	<b>41</b>	<b>B</b>		B-C	B-C		67	1.6	04
50	<b>28</b>	0.25	31	1.3	<b>0.33</b>	<b>41</b>	<b>B</b>		B-C	B-C		65	2.5	05
38	<b>37</b>	0.25	40	1.0	<b>0.26</b>	<b>41</b>	<b>B</b>		B-C	B-C		63	1.8	06
30	<b>46</b>	0.25	46	0.9	<b>0.22</b>	<b>41</b>	<b>B</b>		B-C	B-C		59	1.5	07
23	<b>60</b>	0.18	41	1.0	<b>0.18</b>	<b>41</b>	<b>B</b>		B-C	B-C		56	1.2	08
20	<b>70</b>	0.12	31	1.0	<b>0.12</b>	<b>30</b>	<b>B</b>		B-C	B-C		54	1.0	09
13.7	<b>102</b>	0.09	31	1.0	<b>0.09</b>	<b>29</b>	<b>B</b>		B-C	B-C		49	0.72	10

**A** Motor Flanges Available  
Flange Motore Disponibili

**B** Supplied with Reduction Bushing  
Fornito con Bussola di Riduzione

**B** Available on Request without reduction bushing  
Disponibile a Richiesta senza Bussola di Riduzione

**C** Motor Flange Holes Position  
Posizione Fori Flangia Motore

**EN** Unit **045** is supplied with synthetic oil, providing "long life" lubrication. For mounting position V5-V6 please contact us.  
See table 1 for lubrication and recommended quantity. In table 2 please see possible radial loads and axial loads on the gearbox.

**I** Il riduttore tipo **045** viene fornito lubrificato a vita con olio sintetico. Per posizioni V5-V6 contattare il ns. servizio tecnico.  
Vedi tab.1 per oli e quantità consigliati. In tab.2 sono presenti i carichi radiali e assiali applicabili al riduttore.

**D** Für die Lebensdauerschmierung ist das Getriebe der Größe **045** mit synthetischem Öl befüllt. Bei Einbaulage V5 oder V6 bitten wir um Rücksprache. In Tabelle 1 ist die Schmiermenge und das empfohlene Schmiermittel angegeben. In Tabelle 2 sind die zulässigen Radial - und Axialbelastungen des Getriebes aufgeführt.

**F** Le réducteur de type **045** est fourni lubrifié à vie avec de l'huile synthétique. Concernant les positions V5.V6, contactez notre service d'assistance technique. Voir tableau 1 concernant les huiles et les quantités conseillées. Les charges radiales et axiales applicables au réducteur sont précisées dans le tableau 2.

**E** El reductor tamaño **045** se suministra, lubricado de por vida con aceite sintético. Para las posiciones V5 y V6 contactar con nuestro servicio técnico. Ver tabla 1, para cantidades y aceites recomendados. En la tabla 2, se encuentran las cargas radiales y axiales admitidas por el reductor.

#### LUBRICATION 045 Oil Quantity 0.09 Lt.

**AGIP** Telium VSF 320

**SHELL** Omala S4 WE 320

For all details on lubrication and plugs check our website **tab. 1**  
Per maggiori dettagli su lubrificazione e tappi olio vedi il nostro sito web

#### RADIAL AND AXIAL LOADS

**Output shaft**  
Albero di uscita

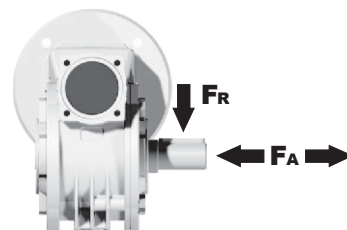

$n_2$ [min <sup>-1</sup> ]	FA [N]	FR [N]
<b>200</b>	180	900
<b>150</b>	200	1000
<b>100</b>	220	1100
<b>75</b>	240	1200
<b>50</b>	260	1400
<b>25</b>	300	1800
<b>15</b>	400	2000

**Input shaft**  
albero in entrata

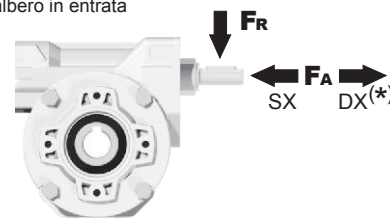

$n_1$ [min <sup>-1</sup> ]	FA [N]	FR [N]
<b>1400</b>	42	210

**\*Strong axial loads in the DX direction are not allowed.**  
Non sono consentiti forti carichi assiali con direzione DX

**tab. 2**

**P045FB...** Basic wormbox  
Riduttore base

Gearbox weight  
peso riduttore **2.40 kg**

M. flanges	Kit code	øF	A
<b>63B5</b>	K050.4.041	138	74
<b>71B5</b>	K050.4.042	160	71.5
<b>56B14</b>	KC40.4.049	80	71.5
<b>63B14</b>	K050.4.047	90	74
<b>71B14</b>	K050.4.045	105	71.5

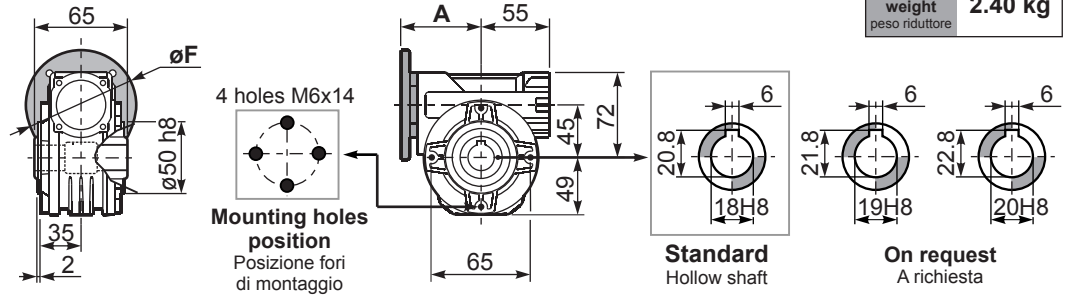

**P045PA...** Feet  
Piedini

**P045PB...** Feet  
Piedini

**P045PV...** Feet  
Piedini

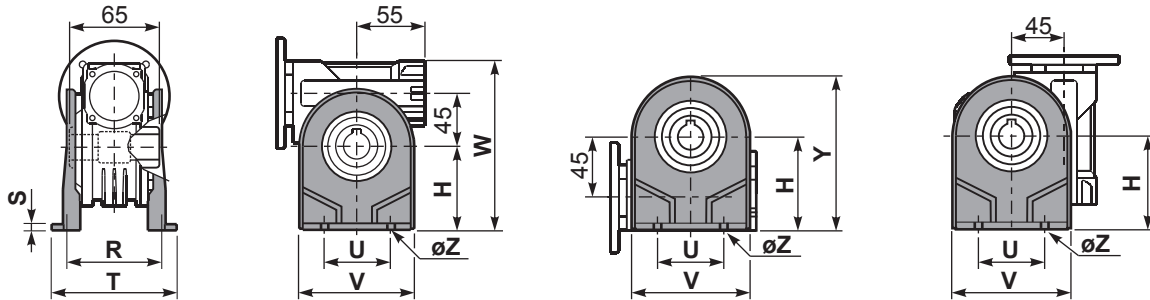

	H	R	S	T	U	V	Y	W	øZ	kit code
type B	72	81	3	100	52	98	121	144	ø10.5	K045.9.022
type S	71	84	8	100	70	90	120	143	ø8	KS045.9.023

**P045FC...** Output flange  
Flangia uscita

**P045BR...** Reaction arm  
Braccio di reazione

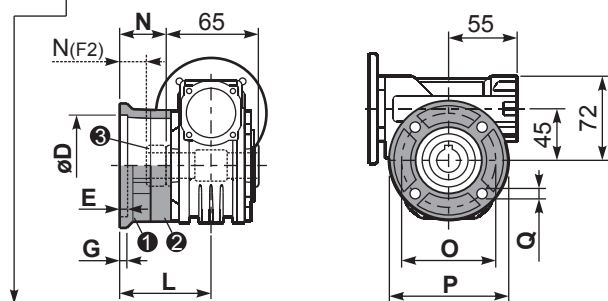

type B	øD	E	G	L	N	O	P	Q	kit code
<b>FC</b>	60 <sup>+0.15</sup> / <sub>+0.05</sub>	9	9	60.5	28	87	110	8.5	1 K045.9.010 2 -
<b>FL</b>	60 <sup>+0.15</sup> / <sub>+0.05</sub>	9	9	90.5	58	87	110	8.5	1 K045.9.010 2 K045.0.200
type S	øD	E	G	L	N	O	P	Q	kit code
<b>F1</b>	95 <sup>+0.20</sup> / <sub>+0.15</sub>	4	11	73.5	41	115	140	9	1 KS045.9.013 2 -
<b>F2</b>	60 <sup>+0.15</sup> / <sub>+0.05</sub>	9	9	60.5	19	87	110	8.5	1 KS045.9.010 2 S045.0.204
<b>F3</b>	80 <sup>+0.15</sup> / <sub>+0.10</sub>	3	8	51.5	19	100	120	9	1 KS045.9.014 2 -

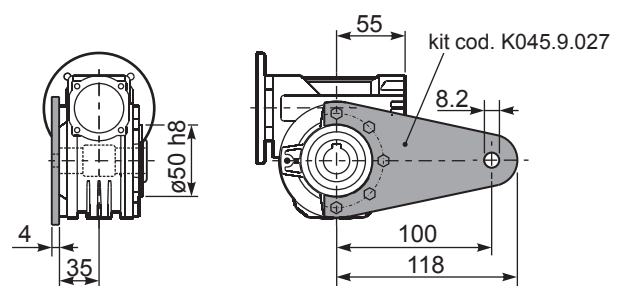

**P045.....S...** Single Shaft  
Albero lento semplice

**P045.....D...** Double Shaft  
Albero lento bisp.

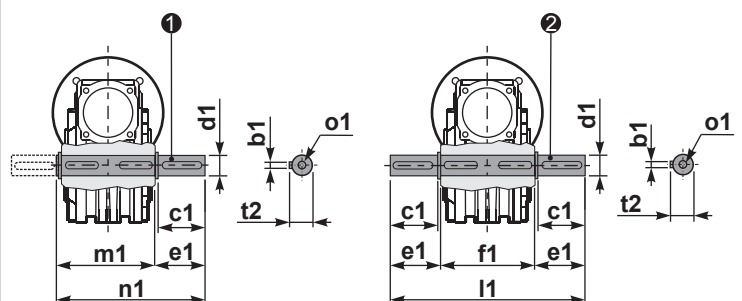

1 kit cod. K045.5.028 type B  
kit cod. KS045.5.030 type S

2 kit cod. K045.5.029 type B  
kit cod. KS045.5.031 type S

**R045FB...** Input shaft  
Albero in entrata

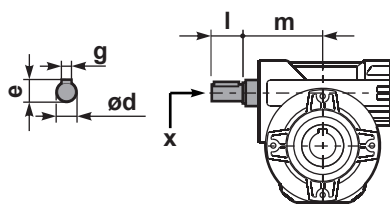

	ød	e	g	l	m	x	kit code
type B	11 h6	12.5	4	30	68	-	1 K045.5.006 PAM71 2 -
type S	-	-	-	-	-	-	1 - 2 -

	b1	c1	d1	e1	f1	l1	m1	n1	t2	o1
type B	6	32	18 <sup>-0.005</sup> / <sub>-0.020</sub>	43	65	151	70	113	20.5	M6x18
type S	6	40	19 <sup>-0.005</sup> / <sub>-0.020</sub>	58.8	65	182	70	128.5	21.5	M8x20



#### QUICK SELECTION / Selezione veloce

input speed ( $n_1$ ) = 1400 min<sup>-1</sup>

Output Speed $n_2$ [min <sup>-1</sup> ]	Ratio $i$	Motor power $P_{1M}$ [kW]	Output torque $M_{2M}$ [Nm]	Service factor f.s.	Nominal power $P_{1R}$ [kW]	Nominal torque $M_{2R}$ [Nm]	Available B5 motor flanges			Available B14 motor flanges				Dynamic efficiency <b>RD</b>	Tooth Module [mm]	Ratios code
							-B	-C	-D	-O	-P	-Q	-R			
							63	71	80	56	63	71	80			
200	7	0.75	29	1.9	1.5	57	B	B			B-C	B		82	2.5	01
140	10	0.75	41	1.5	1.1	62	B	B			B-C	B		80	2.4	02
100	14	0.75	57	1.2	0.90	68	B	B			B-C	B		79	2.6	03
78	18	0.55	51	1.2	0.67	62	B	B			B-C	B		75	2.0	04
54	26	0.55	67	1.0	0.54	66	B	B			B-C	B		69	2.7	05
47	30	0.55	79	0.9	0.50	72	B	B			B-C	B		70	2.5	12
39	36	0.37	63	1.2	0.43	72	B			B-C	B-C			69	2.1	06
33	43	0.37	72	1.0	0.35	68	B			B-C	B-C			66	1.8	07
23	60	0.25	59	1.0	0.26	62	B			B-C	B-C			58	1.3	08
21	68	0.25	66	0.9	0.22	58	B			B-C	B-C			57	1.2	09
17.5	80	0.18	53	1.1	0.19	57	B			B-C	B-C			54	1.0	10
14	100	0.12	41	1.3	0.15	51	B			B-C	B-C			50	0.8	11

**A** Motor Flanges Available  
Flange Motore Disponibili

**B** Supplied with Reduction Bushing  
Fornito con Bussola di Riduzione

**B** Available on Request without reduction bushing  
Disponibile a Richiesta senza Bussola di Riduzione

**C** Motor Flange Holes Position  
Posizione Fori Flangia Motore

**EN** Unit 050 is supplied with synthetic oil, providing "long life" lubrication. For mounting position V5-V6 please contact us. See table 1 for lubrication and recommended quantity. In table 2 please see possible radial loads and axial loads on the gearbox.

**I** Il riduttore tipo 050 viene fornito lubrificato a vita con olio sintetico. Per posizioni V5-V6 contattare il ns. servizio tecnico. Vedi tab.1 per oli e quantità consigliati. In tab.2 sono presenti i carichi radiali e assiali applicabili al riduttore.

**D** Für die Lebensdauerschmierung ist das Getriebe der Größe 050 mit synthetischem Öl befüllt. Bei Einbaulage V5 oder V6 bitten wir um Rücksprache. In Tabelle 1 ist die Schmiermenge und das empfohlene Schmiermittel angegeben. In Tabelle 2 sind die zulässigen Radial - und Axialbelastungen des Getriebes aufgeführt.

**F** Le réducteur de type 050 est fourni lubrifié à vie avec de l'huile synthétique. Concernant les positions V5.V6, contactez notre service d'assistance technique. Voir tableau 1 concernant les huiles et les quantités conseillées. Les charges radiales et axiales applicables au réducteur sont précisées dans le tableau 2.

**E** El reductor tamaño 050 se suministra, lubricado de por vida con aceite sintético. Para las posiciones V5 y V6 contactar con nuestro servicio técnico. Ver tabla 1, para cantidades y aceites recomendados. En la tabla 2, se encuentran las cargas radiales y axiales admitidas por el reductor.

#### LUBRICATION 050 Oil Quantity 0.14 Lt.

**AGIP** Telium VSF 320

**SHELL** Omala S4 WE 320

For all details on lubrication and plugs check our website **tab. 1**  
Per maggiori dettagli su lubrificazione e tappi olio vedi il nostro sito web

#### RADIAL AND AXIAL LOADS

**Output shaft**  
Albero di uscita

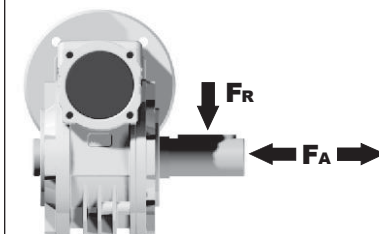

$n_2$ [min <sup>-1</sup> ]	FA [N]	FR [N]
200	240	1200
150	280	1400
100	300	1500
75	340	1700
50	380	1900
25	480	2500
15	560	2800

**Input shaft**  
albero in entrata

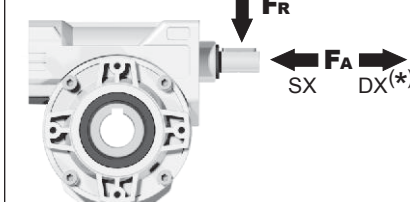

$n_1$ [min <sup>-1</sup> ]	FA [N]	FR [N]
1400	76	380

\*Strong axial loads in the DX direction are not allowed.  
Non sono consentiti forti carichi assiali con direzione DX

tab. 2

**P050FB...** Basic wormbox  
Riduttore base

Gearbox weight  
peso riduttore **3.00 kg**

M. flanges	Kit code	øF	A
<b>63B5</b>	K050.4.041	138	78.5
<b>71B5</b>	K050.4.042	160	76
<b>80B5</b>	K050.4.043	200	76.5
<b>56B14</b>	KC40.4.049	80	76
<b>63B14</b>	K050.4.047	90	78.5
<b>71B14</b>	K050.4.045	105	76
<b>80B14</b>	K050.4.046	120	76.5

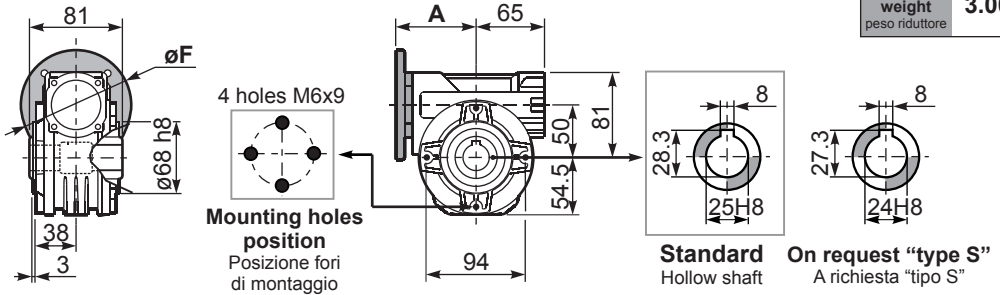

**P050PA...** Feet  
Piedini

**P050PB...** Feet  
Piedini

**P050PV...** Feet  
Piedini

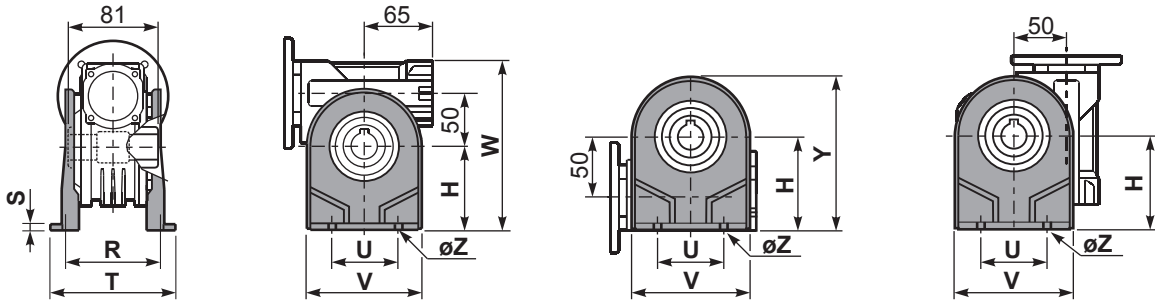

	H	R	S	T	U	V	Y	W	øZ	kit code
type B	82	98.5	3.5	123	63	113	138.5	163	ø10.5	K050.9.022
type S	85	96	10	114	85	110	139.5	166	ø10	KS050.9.023

**P050FC...** Output flange  
Flangia uscita

**P050BR...** Reaction arm  
Braccio di reazione

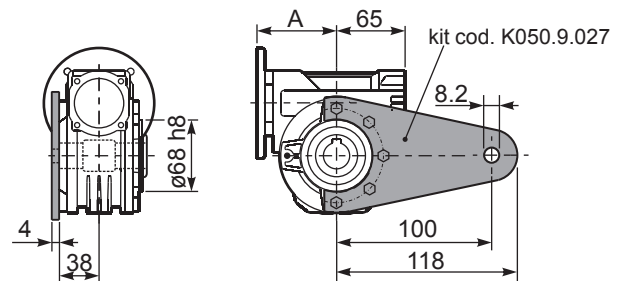
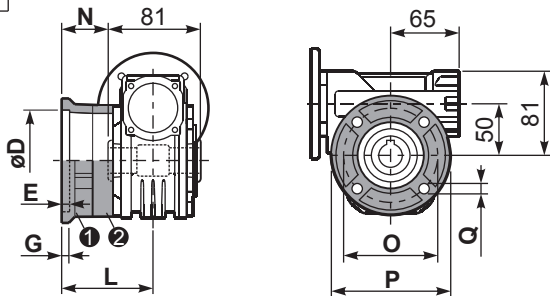

type B	øD	E	G	L	N	O	P	Q	kit code
<b>FC</b>	70 <sup>+0.20</sup> / <sub>+0.15</sub>	9	12	85	44.5	90	123	10.5	1 K050.9.010 2 -
<b>FL</b>	70 <sup>+0.20</sup> / <sub>+0.15</sub>	9	12	114.5	74	90	123	10.5	1 K050.9.010 2 K050.0.200

type S	øD	E	G	L	N	O	P	Q	kit code
<b>F1</b>	110 <sup>+0.20</sup> / <sub>+0.15</sub>	4	11	83.5	43	130	160	10	1 KS050.9.012 2 -
<b>F2</b>	70 <sup>+0.20</sup> / <sub>+0.15</sub>	9	12	76.5	36	90	123	10.5	1 KS050.9.014 2 -
<b>F3</b>	95 <sup>+0.20</sup> / <sub>+0.15</sub>	4	10	66.5	26	115	140	10	1 KS050.9.013 2 -

**P050.....S...** Single Shaft  
Albero lento semplice

**P050.....D...** Double Shaft  
Albero lento bisp.

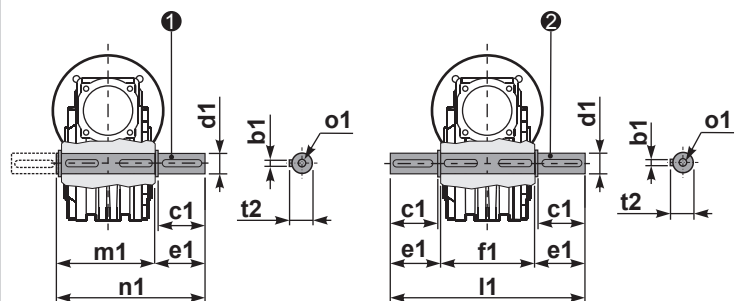

1 kit cod. K050.5.028 type B  
kit cod. KS050.5.030 type S

2 kit cod. K050.5.029 type B  
kit cod. KS050.5.031 type S

**R050FB...** Input shaft  
Albero in entrata

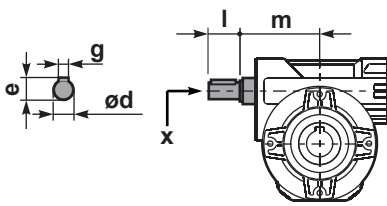

	ød	e	g	l	m	x	kit code
type B	16 h6	18	5	30	74.5	M6x16	1 K050.5.006 PAM71 2 K050.5.007 PAM80
type S	14 h6	16	5	30	74.5	M5x10	1 KS050.5.008 PAM71 2 KS050.5.009 PAM80

	b1	c1	d1	e1	f1	l1	m1	n1	t2	o1
type B	8	52	25 <sup>-0.005</sup> / <sub>-0.020</sub>	59.5	81	200	86.5	146	28	M8x20
type S	8	50	24 <sup>-0.005</sup> / <sub>-0.020</sub>	68.8	81	218	86.5	155	27	M8x20



#### QUICK SELECTION / Selezione veloce

input speed ( $n_1$ ) = 1400 min<sup>-1</sup>

Output Speed $n_2$ [min <sup>-1</sup> ]	Ratio $i$	Motor power $P_{1M}$ [kW]	Output torque $M_{2M}$ [Nm]	Service factor f.s.	Nominal power $P_{1R}$ [kW]	Nominal torque $M_{2R}$ [Nm]	Available B5 motor flanges				Available B14 motor flanges			Dynamic efficiency <b>RD</b>	Tooth Module  [mm]	Ratios code 	
							-B	-C	-D	-E	-Q	-R	-T				
							63	71	80	90	71	80	90				
200	<b>7</b>	1.8	71	1.8	<b>3.2</b>	<b>125</b>		<b>B</b>	<b>B</b>			<b>B-C</b>	<b>B-C</b>		83	3.1	01
140	<b>10</b>	1.8	99	1.4	<b>2.4</b>	<b>134</b>		<b>B</b>	<b>B</b>			<b>B-C</b>	<b>B-C</b>		81	3.1	02
93	<b>15</b>	1.5	121	1.1	<b>1.7</b>	<b>138</b>		<b>B</b>	<b>B</b>			<b>B-C</b>	<b>B-C</b>		79	3.1	03
74	<b>19</b>	1.1	111	1.2	<b>1.4</b>	<b>138</b>		<b>B</b>	<b>B</b>			<b>B-C</b>	<b>B-C</b>		78	2.6	04
58	<b>24</b>	1.1	135	1.0	<b>1.2</b>	<b>142</b>		<b>B</b>	<b>B</b>			<b>B-C</b>	<b>B-C</b>		75	2.0	05
47	<b>30</b>	1.1	167	0.9	<b>0.96</b>	<b>146</b>		<b>B</b>	<b>B</b>			<b>B-C</b>	<b>B-C</b>		74	3.2	06
39	<b>36</b>	0.75	125	1.2	<b>0.88</b>	<b>147</b>		<b>B</b>	<b>B</b>			<b>B-C</b>	<b>B-C</b>		68	2.7	07
31	<b>45</b>	0.55	111	1.2	<b>0.67</b>	<b>135</b>	<b>B</b>	<b>B</b>				<b>B-C</b>	<b>C</b>		66	2.1	08
23	<b>60</b>	0.55	140	0.9	<b>0.51</b>	<b>130</b>	<b>B</b>	<b>B</b>				<b>B-C</b>	<b>C</b>		62	1.6	12
21	<b>67</b>	0.55	151	0.8	<b>0.45</b>	<b>124</b>	<b>B</b>	<b>B</b>				<b>B-C</b>	<b>C</b>		60	1.5	09
17.5	<b>80</b>	0.37	115	1.0	<b>0.38</b>	<b>119</b>	<b>B</b>	<b>B</b>				<b>B-C</b>	<b>C</b>		57	1.3	10
14.9	<b>94</b>	0.37	123	1.0	<b>0.36</b>	<b>119</b>	<b>B</b>	<b>B</b>				<b>B-C</b>	<b>C</b>		52	1.1	11

**Motor Flanges Available**  
Flange Motore Disponibili

**B) Supplied with Reduction Bushing**  
Fornito con Bussola di Riduzione

**B) Available on Request without reduction bushing**  
Disponibile a Richiesta senza Bussola di Riduzione

**C) Motor Flange Holes Position**  
Posizione Fori Flangia Motore

**EN** Unit **063** is supplied with synthetic oil, providing "long life" lubrication. For mounting position V5-V6 please contact us. See table 1 for lubrication and recommended quantity. In table 2 please see possible radial loads and axial loads on the gearbox.

**I** Il riduttore tipo **063** viene fornito lubrificato a vita con olio sintetico. Per posizioni V5-V6 contattare il ns. servizio tecnico. Vedi tab.1 per oli e quantità consigliati. In tab.2 sono presenti i carichi radiali e assiali applicabili al riduttore.

**D** Für die Lebensdauerschmierung ist das Getriebe der Größe **063** mit synthetischem Öl befüllt. Bei Einbaulage V5 oder V6 bitten wir um Rücksprache. In Tabelle 1 ist die Schmiermenge und das empfohlene Schmiermittel angegeben. In Tabelle 2 sind die zulässigen Radial - und Axialbelastungen des Getriebes aufgeführt.

**F** Le réducteur de type **063** est fourni lubrifié à vie avec de l'huile synthétique. Concernant les positions V5.V6, contactez notre service d'assistance technique. Voir tableau 1 concernant les huiles et les quantités conseillées. Les charges radiales et axiales applicables au réducteur sont précisées dans le tableau 2.

**E** El reductor tamaño **063** se suministra, lubricado de por vida con aceite sintético. Para las posiciones V5 y V6 contactar con nuestro servicio técnico. Ver tabla 1, para cantidades y aceites recomendados. En la tabla 2, se encuentran las cargas radiales y axiales admitidas por el reductor.

#### LUBRICATION 063 Oil Quantity 0.40 Lt.

**AGIP** Telium VSF 320

**SHELL** Omala S4 WE 320

For all details on lubrication and plugs check our website **tab. 1**  
Per maggiori dettagli su lubrificazione e tappi olio vedi il nostro sito web

#### RADIAL AND AXIAL LOADS

**Output shaft**  
Albero di uscita

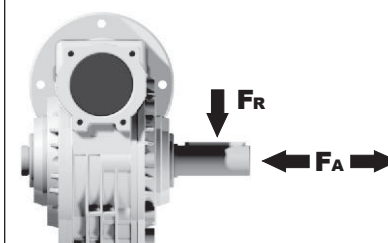

$n_2$ [min <sup>-1</sup> ]	FA [N]	FR [N]
<b>200</b>	360	1800
<b>150</b>	400	2000
<b>100</b>	460	2300
<b>75</b>	500	2500
<b>50</b>	600	3000
<b>25</b>	700	3800
<b>15</b>	800	4000

**Input shaft**  
albero in entrata

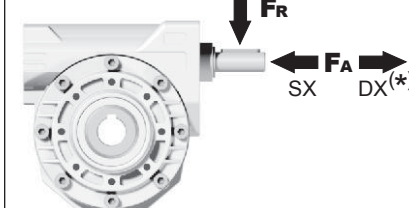

$n_1$ [min <sup>-1</sup> ]	FA [N]	FR [N]
<b>1400</b>	90	450

**\*Strong axial loads in the DX direction are not allowed.**  
Non sono consentiti forti carichi assiali con direzione DX

**tab. 2**

**P063FB...** Basic wormbox  
Riduttore base

Gearbox weight  
peso riduttore **6.00 kg**

M. flanges	Kit code	øF	A
<b>63B5</b>	K063.4.041	140	99.5
<b>71B5</b>	K063.4.042	160	97.5
<b>80/90B5</b>	K063.4.043	200	99.5
<b>71B14</b>	K063.4.047	105	97.5
<b>80B14</b>	K063.4.046	120	99.5
<b>90B14</b>	K063.4.041	140	99.5

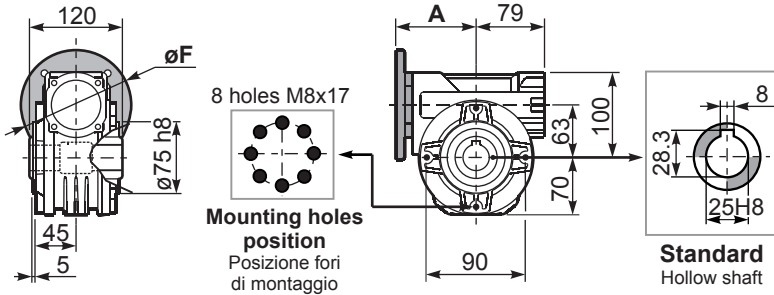

**P063PA...** Feet  
Piedini

**P063PB...** Feet  
Piedini

**P063PV...** Feet  
Piedini

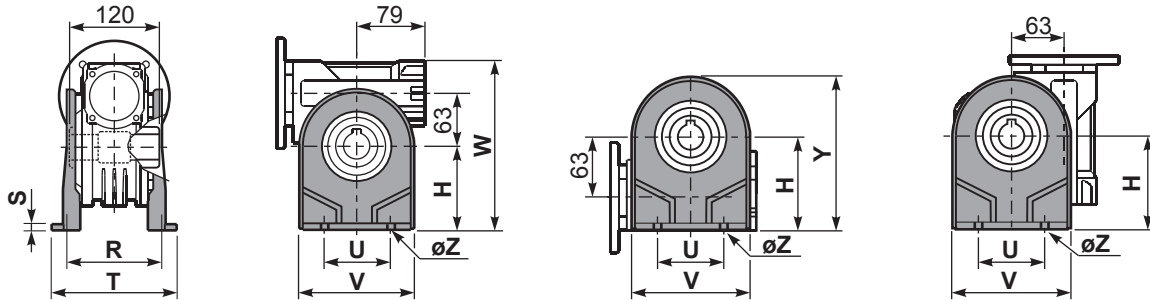

	H	R	S	T	U	V	Y	W	øZ	kit code
type B	100	111	4	144	95	133	170	200	ø10.5	K063.9.022
type S	-	-	-	-	-	-	-	-	-	-

**P063FC...** Output flange  
Flangia uscita

**P063BR...** Reaction arm  
Braccio di reazione

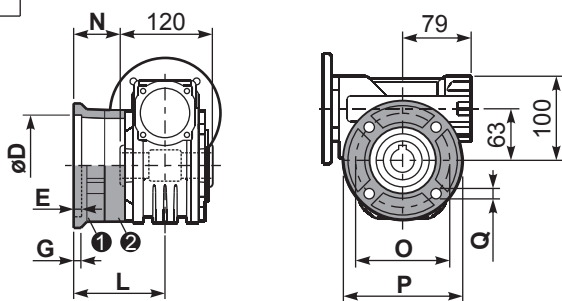

type B	øD	E	G	L	N	O	P	Q	kit code
<b>FC</b>	115 <sup>+0.20</sup> / <sub>+0.15</sub>	7	13	86	26	150	175	11	① K063.9.010 ② -
<b>FL</b>	115 <sup>+0.20</sup> / <sub>+0.15</sub>	7	13	116	56	150	175	11	① K063.9.010 ② K063.0.200
type S	øD	E	G	L	N	O	P	Q	kit code
<b>F1</b>	130 <sup>+0.20</sup> / <sub>+0.15</sub>	7	13	102	42	165	200	13	① KS070.9.013 ② -
<b>F2</b>	115 <sup>+0.20</sup> / <sub>+0.15</sub>	7	13	116	56	150	175	11	① KS063.9.013 ② -
<b>F3</b>	110 <sup>+0.035</sup> / <sub>0</sub>	5	11	82	22	130	160	10	① KS063.9.011 ② -

**P063.....S...** Single Shaft  
Albero lento semplice

**P063.....D...** Double Shaft  
Albero lento bisp.

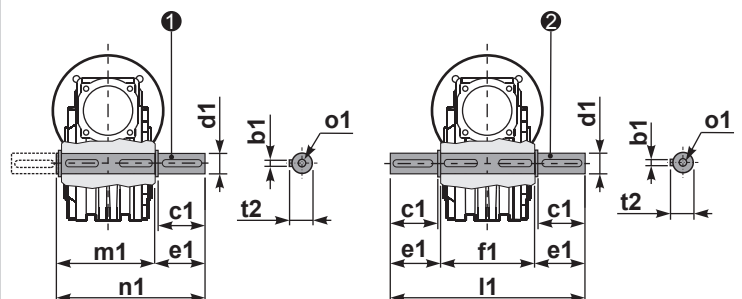

① kit cod. K063.5.028 type B

② kit cod. K063.5.029 type B

**R063FB...** Input shaft  
Albero in entrata

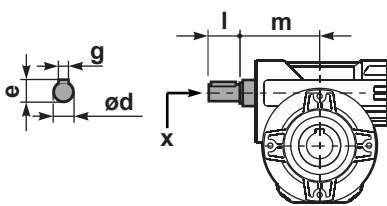

	ød	e	g	l	m	x	kit code
type B	18 h6	20.5	6	45	93	M6x16	① K063.5.006 PAM80 ② K063.5.007 PAM90
type S	19 h6	21.5	6	40	93	M8x20	① KS063.5.008 PAM80 ② KS063.5.009 PAM90

	b1	c1	d1	e1	f1	l1	m1	n1	t2	o1
type B	8	60	25 <sup>-0.005</sup> / <sub>-0.020</sub>	63.2	120	246.4	126.8	190	28	M8x20
type S	-	-	-	-	-	-	-	-	-	-

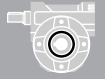

#### QUICK SELECTION / Selezione veloce

input speed ( $n_1$ ) = 1400 min<sup>-1</sup>

Output Speed $n_2$ [min <sup>-1</sup> ]	Ratio $i$	Motor power $P_{1M}$ [kW]	Output torque $M_{2M}$ [Nm]	Service factor f.s.	Nominal power $P_{1R}$ [kW]	Nominal torque $M_{2R}$ [Nm]	Available B5 motor flanges				Available B14 motor flanges			Dynamic efficiency <b>RD</b>	Tooth Module [mm]	Ratios code	
							-B	-C	-D	-E	-Q	-R	-T				
							63	71	80	90	71	80	90				
200	<b>7</b>	1.8	71	2.3	<b>4.1</b>	<b>162</b>		<b>B</b>	<b>B</b>			<b>B-C</b>	<b>B-C</b>		83	3.1	01
140	<b>10</b>	1.8	99	1.7	<b>3.1</b>	<b>173</b>		<b>B</b>	<b>B</b>			<b>B-C</b>	<b>B-C</b>		81	3.1	02
93	<b>15</b>	1.5	121	1.5	<b>2.2</b>	<b>178</b>		<b>B</b>	<b>B</b>			<b>B-C</b>	<b>B-C</b>		79	3.1	03
74	<b>19</b>	1.5	152	1.2	<b>1.8</b>	<b>178</b>		<b>B</b>	<b>B</b>			<b>B-C</b>	<b>B-C</b>		78	2.6	04
58	<b>24</b>	1.5	184	1.0	<b>1.5</b>	<b>185</b>		<b>B</b>	<b>B</b>			<b>B-C</b>	<b>B-C</b>		75	2.0	05
47	<b>30</b>	1.5	227	0.8	<b>1.3</b>	<b>189</b>		<b>B</b>	<b>B</b>			<b>B-C</b>	<b>B-C</b>		74	3.2	06
39	<b>36</b>	1.1	184	1.0	<b>1.1</b>	<b>191</b>		<b>B</b>	<b>B</b>	<b>B</b>		<b>B-C</b>	<b>B-C</b>		68	2.7	07
31	<b>45</b>	0.75	152	1.2	<b>0.86</b>	<b>175</b>	<b>B</b>	<b>B</b>				<b>B-C</b>	<b>C</b>		66	2.1	08
23	<b>60</b>	0.55	140	1.2	<b>0.66</b>	<b>168</b>	<b>B</b>	<b>B</b>				<b>B-C</b>	<b>C</b>		62	1.6	12
21	<b>67</b>	0.55	151	1.1	<b>0.58</b>	<b>159</b>	<b>B</b>	<b>B</b>				<b>B-C</b>	<b>C</b>		60	1.5	09
17.5	<b>80</b>	0.37	115	1.3	<b>0.49</b>	<b>153</b>	<b>B</b>	<b>B</b>				<b>B-C</b>	<b>C</b>		57	1.3	10
14.9	<b>94</b>	0.37	123	1.1	<b>0.39</b>	<b>130</b>	<b>B</b>	<b>B</b>				<b>B-C</b>	<b>C</b>		52	1.1	11

**Motor Flanges Available**  
Flange Motore Disponibili

**B) Supplied with Reduction Bushing**  
Fornito con Bussola di Riduzione

**B) Available on Request without reduction bushing**  
Disponibile a Richiesta senza Bussola di Riduzione

**C) Motor Flange Holes Position**  
Posizione Fori Flangia Motore

**EN** Unit **63A** is supplied with synthetic oil, providing "long life" lubrication. For mounting position V5-V6 please contact us. See table 1 for lubrication and recommended quantity. In table 2 please see possible radial loads and axial loads on the gearbox.

**I** Il riduttore tipo **63A** viene fornito lubrificato a vita con olio sintetico. Per posizioni V5-V6 contattare il ns. servizio tecnico. Vedi tab.1 per oli e quantità consigliati. In tab.2 sono presenti i carichi radiali e assiali applicabili al riduttore.

**D** Für die Lebensdauerschmierung ist das Getriebe der Größe **63A** mit synthetischem Öl befüllt. Bei Einbaulage V5 oder V6 bitten wir um Rücksprache. In Tabelle 1 ist die Schmiermenge und das empfohlene Schmiermittel angegeben. In Tabelle 2 sind die zulässigen Radial- und Axialbelastungen des Getriebes aufgeführt.

**F** Le réducteur de type **63A** est fourni lubrifié à vie avec de l'huile synthétique. Concernant les positions V5.V6, contactez notre service d'assistance technique. Voir tableau 1 concernant les huiles et les quantités conseillées. Les charges radiales et axiales applicables au réducteur sont précisées dans le tableau 2.

**E** El reductor tamaño **63A** se suministra, lubricado de por vida con aceite sintético. Para las posiciones V5 y V6 contactar con nuestro servicio técnico. Ver tabla 1, para cantidades y aceites recomendados. En la tabla 2, se encuentran las cargas radiales y axiales admitidas por el reductor.

#### LUBRICATION 63A Oil Quantity 0.40 Lt.

**AGIP** Telium VSF 320

**SHELL** Omala S4 WE 320

For all details on lubrication and plugs check our website **tab. 1**  
Per maggiori dettagli su lubrificazione e tappi olio vedi il nostro sito web

#### RADIAL AND AXIAL LOADS

##### Output shaft

Albero di uscita

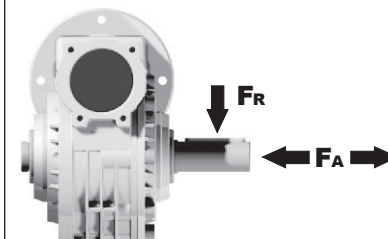

$n_2$ [min <sup>-1</sup> ]	FA [N]	FR [N]
<b>200</b>	360	1800
<b>150</b>	400	2000
<b>100</b>	460	2300
<b>75</b>	500	2500
<b>50</b>	600	3000
<b>25</b>	700	3800
<b>15</b>	800	4000

##### Input shaft

albero in entrata

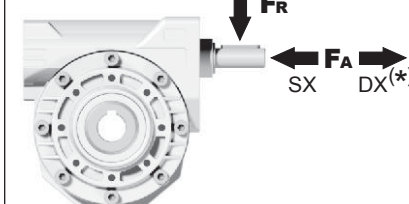

$n_1$ [min <sup>-1</sup> ]	FA [N]	FR [N]
<b>1400</b>	90	450

**\*Strong axial loads in the DX direction are not allowed.**  
Non sono consentiti forti carichi assiali con direzione DX

**tab. 2**



**P63AFB...** Basic wormbox  
Riduttore base

Gearbox weight  
peso riduttore **6.00 kg**

M. flanges	Kit code	øF	A
<b>63B5</b>	K063.4.041	140	99.5
<b>71B5</b>	K063.4.042	160	97.5
<b>80/90B5</b>	K063.4.043	200	99.5
<b>71B14</b>	K063.4.047	105	97.5
<b>80B14</b>	K063.4.046	120	99.5
<b>90B14</b>	K063.4.041	140	99.5

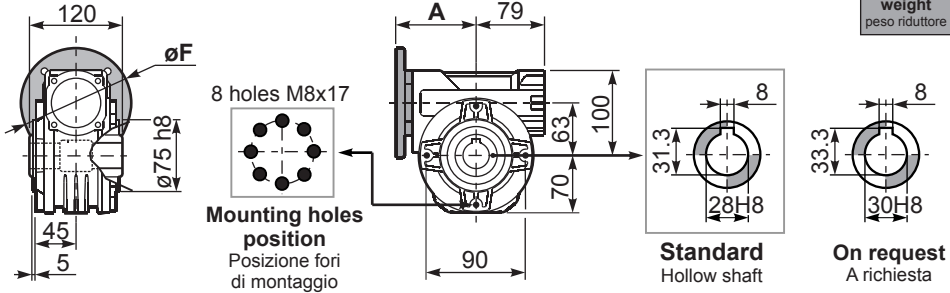

**P63APA...** Feet  
Piedini

**P63APB...** Feet  
Piedini

**P63APV...** Feet  
Piedini

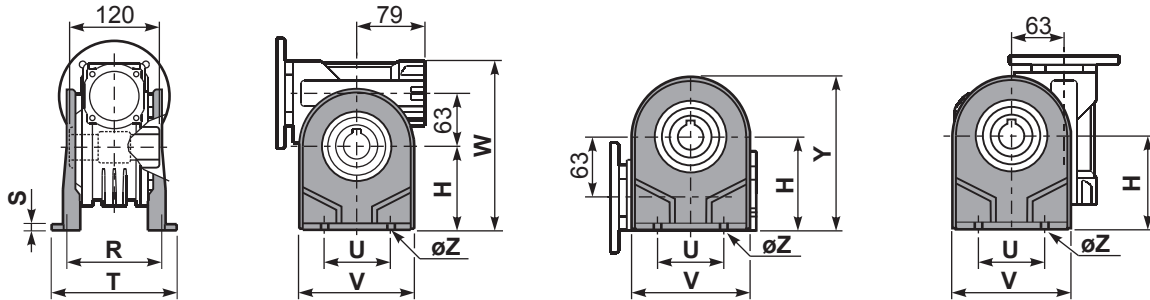

	H	R	S	T	U	V	Y	W	øZ	kit code
type B	115	115	12	142	120	156	185	215	ø11	K070.9.022
type S	-	-	-	-	-	-	-	-	-	-

**P63AFC...** Output flange  
Flangia uscita

**P63ABR...** Reaction arm  
Braccio di reazione

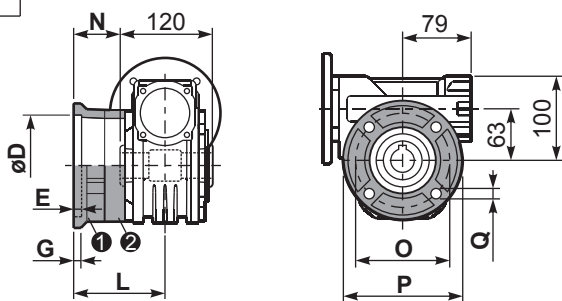

type B	øD	E	G	L	N	O	P	Q	kit code
<b>FC</b>	130 <sup>+0.20</sup> / <sub>+0.15</sub>	7	13	85	25	165	200	13	① K070.9.010 ② -
<b>FL</b>	130 <sup>+0.20</sup> / <sub>+0.15</sub>	7	13	111	51	165	200	13	① K070.9.010 ② K070.0.200
type S	øD	E	G	L	N	O	P	Q	kit code
<b>F1</b>	130 <sup>+0.20</sup> / <sub>+0.15</sub>	7	13	111	51	165	200	13	① KS070.9.014 ② -
<b>F2</b>	115 <sup>+0.20</sup> / <sub>+0.15</sub>	7	13	116	56	150	175	11	① KS063.9.013 ② -
<b>F3</b>	110 <sup>+0.035</sup> / <sub>0</sub>	5	13.5	84.5	24.5	130	160	11	① KS070.9.011 ② -

**P63A...S...** Single Shaft  
Albero lento semplice

**P63A...D...** Double Shaft  
Albero lento bisp.

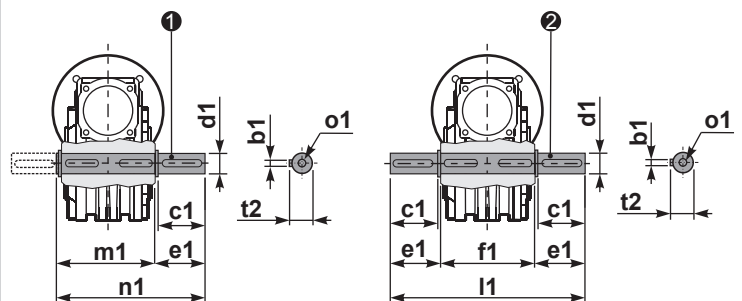

① kit cod. K070.5.028 type B

② kit cod. K070.5.029 type B

**R63AFB...** Input shaft  
Albero in entrata

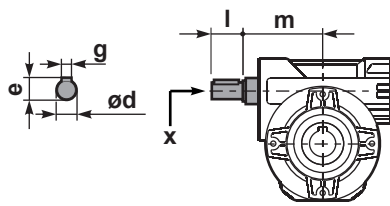

	ød	e	g	l	m	x	kit code
type B	18 h6	20.5	6	45	93	M6x16	① K063.5.006 PAM80 ② K063.5.007 PAM90
type S	19 h6	21.5	6	40	93	M8x20	① KS063.5.008 PAM80 ② KS063.5.009 PAM90

	b1	c1	d1	e1	f1	l1	m1	n1	t2	o1
type B	8	60	28 <sup>-0.005</sup> / <sub>-0.020</sub>	63.5	120	247	127.5	191	31	M8x20
type S	-	-	-	-	-	-	-	-	-	-



#### QUICK SELECTION / Selezione veloce

input speed ( $n_1$ ) = 1400 min<sup>-1</sup>

Output Speed $n_2$ [min <sup>-1</sup> ]	Ratio $i$	Motor power $P_{1M}$ [kW]	Output torque $M_{2M}$ [Nm]	Service factor f.s.	Nominal power $P_{1R}$ [kW]	Nominal torque $M_{2R}$ [Nm]	Available B5 motor flanges				Available B14 motor flanges			Dynamic efficiency RD	Tooth Module [mm]	Ratios code	
							-C	-D	-E	-F	-R	-T	-U				
							71	80	90	100 112	80	90	100 112				
200	7	4.0	168	1.5	6.1	257		B	B			B	B		88	4.23	01
140	10	4.0	218	1.3	5.2	284		B	B			B	B		80	4.2	02
100	14	3.0	223	1.4	4.1	305		B	B			B	B		78	4.5	03
70	20	2.2	237	1.2	2.7	294		B	B			B	B		79	3.4	04
64	22	2.2	258	1.1	2.5	294		B	B			B	B		78	3.1	05
50	28	2.2	315	1.1	2.4	347		B	B	B		B	B		75	4.7	06
37	38	1.5	276	1.2	1.8	336	B	B				B			71	3.5	07
30	46	1.5	320	1.0	1.5	326	B	B				B			68	3.1	08
27	52	1.1	258	1.1	1.2	289	B	B				B			66	2.7	09
21	67	1.1	327	0.9	0.97	289	B	B				B			65	2.1	10
18.9	74	0.75	220	1.2	0.91	268	B	B				B			58	1.9	11
14.6	96	0.55	191	1.3	0.70	242	B	B				B			53	1.5	12

**A** Motor Flanges Available  
Flange Motore Disponibili

**B** Supplied with Reduction Bushing  
Fornito con Bussola di Riduzione

**B** Available on Request without reduction bushing  
Disponibile a Richiesta senza Bussola di Riduzione

**C** Motor Flange Holes Position  
Posizione Fori Flangia Motore

**EN** Unit **085** is supplied with synthetic oil, providing "long life" lubrication. For mounting position V5-V6 please contact us.  
See table 1 for lubrication and recommended quantity. In table 2 please see possible radial loads and axial loads on the gearbox.

**I** Il riduttore tipo **085** viene fornito lubrificato a vita con olio sintetico. Per posizioni V5-V6 contattare il ns. servizio tecnico.  
Vedi tab.1 per oli e quantità consigliati. In tab.2 sono presenti i carichi radiali e assiali applicabili al riduttore.

**D** Für die Lebensdauerschmierung ist das Getriebe der Größe **085** mit synthetischem Öl befüllt. Bei Einbaulage V5 oder V6 bitten wir um Rücksprache. In Tabelle 1 ist die Schmiermenge und das empfohlene Schmiermittel angegeben. In Tabelle 2 sind die zulässigen Radial- und Axialbelastungen des Getriebes aufgeführt.

**F** Le réducteur de type **085** est fourni lubrifié à vie avec de l'huile synthétique. Concernant les positions V5.V6, contactez notre service d'assistance technique. Voir tableau 1 concernant les huiles et les quantités conseillées. Les charges radiales et axiales applicables au réducteur sont précisées dans le tableau 2.

**E** El reductor tamaño **085** se suministra, lubricado de por vida con aceite sintético. Para las posiciones V5 y V6 contactar con nuestro servicio técnico. Ver tabla 1, para cantidades y aceites recomendados. En la tabla 2, se encuentran las cargas radiales y axiales admitidas por el reductor.

#### LUBRICATION 085 Oil Quantity 1.20 Lt.

**AGIP** Telium VSF 320

**SHELL** Omala S4 WE 320

For all details on lubrication and plugs check our website **tab. 1**  
Per maggiori dettagli su lubrificazione e tappi olio vedi il nostro sito web

#### RADIAL AND AXIAL LOADS

##### Output shaft

Albero di uscita

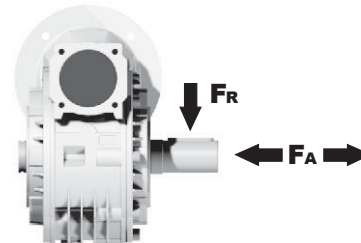

$n_2$ [min <sup>-1</sup> ]	FA [N]	FR [N]
200	500	2500
150	580	2900
100	600	3000
75	700	3500
50	800	4000
25	1000	5000
15	1160	5800

##### Input shaft

albero in entrata

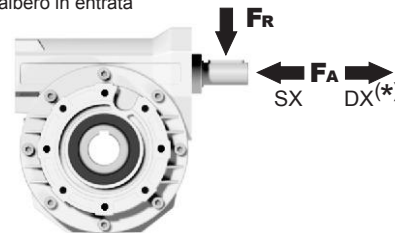

$n_1$ [min <sup>-1</sup> ]	FA [N]	FR [N]
1400	160	809

\*Strong axial loads in the DX direction are not allowed.  
Non sono consentiti forti carichi assiali con direzione DX

tab. 2

**P085FB...** Basic wormbox  
Riduttore base

Gearbox weight  
peso riduttore **11.00 kg**

M. flanges	Kit code	øF	A
<b>71B5</b>	K023.4.041	160	116
<b>80/90B5</b>	K023.4.042	200	118
<b>100/112B5</b>	K023.4.043	250	127
<b>80B14</b>	K085.4.046	120	118
<b>90B14</b>	K085.4.045	140	118
<b>100/112B14</b>	K023.4.041	160	116

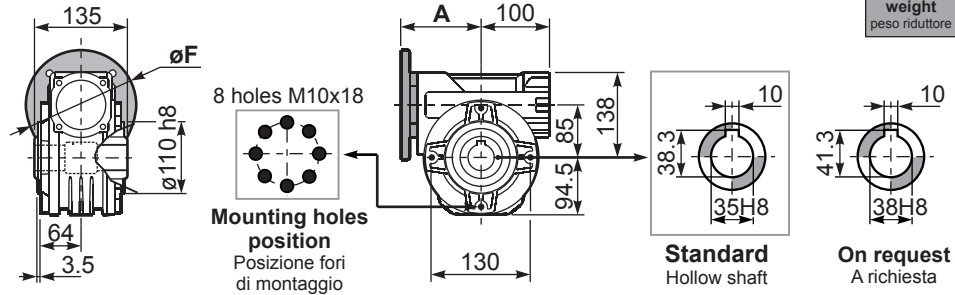

**P085PA...** Feet  
Piedini

**P085PB...** Feet  
Piedini

**P085PV...** Feet  
Piedini

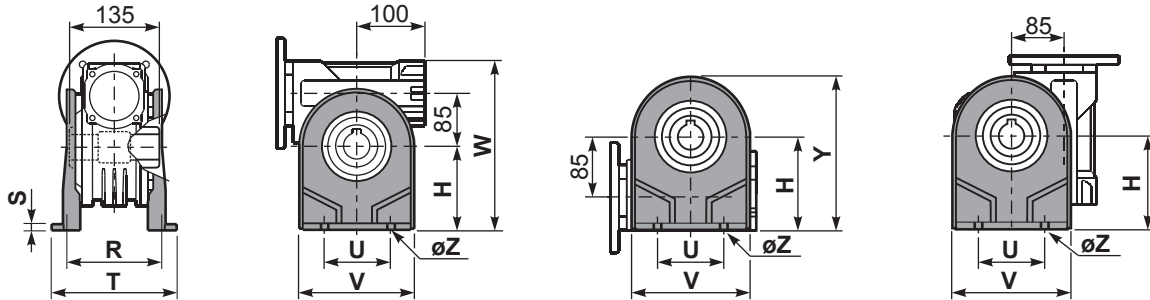

	H	R	S	T	U	V	Y	W	øZ	kit code
type B	142	145	5	182	140	180	236.5	280	ø10.5	K085.9.022
type S	-	-	-	-	-	-	-	-	-	-

**P085FC...** Output flange  
Flangia uscita

**P085BR...** Reaction arm  
Braccio di reazione

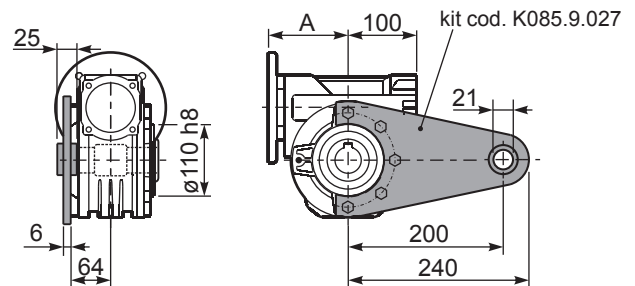
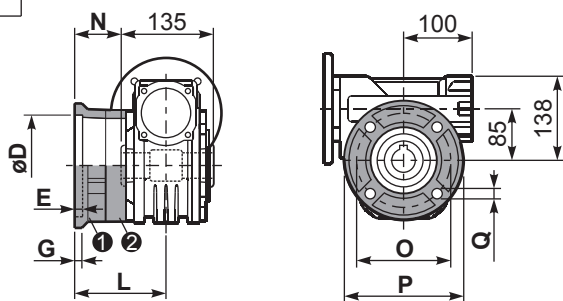

type B	øD	E	G	L	N	O	P	Q	kit code
<b>FC</b>	152 <sup>+0.06</sup> / <sub>+0.00</sub>	5	16	108	40.5	176	205	13	① K085.9.010 ② -
<b>FL</b>	152 <sup>+0.06</sup> / <sub>+0.00</sub>	5	16	148.5	81	176	205	13	① K085.9.010 ② K085.0.201
type S	øD	E	G	L	N	O	P	Q	kit code
<b>F1</b>	130 H7	5	13	117.5	50	165	200	11.5	① KS085.9.012 ② -
<b>F2</b>	152 <sup>+0.06</sup> / <sub>+0.00</sub>	5	15	147.5	80	180	205	12.5	① KS085.9.013 ② -
<b>F4</b>	130 H7	5	13	106.5	39	165	200	13	① KS085.9.015 ② -

**P085.....S...** Single Shaft  
Albero lento semplice

**P085.....D...** Double Shaft  
Albero lento bisp.

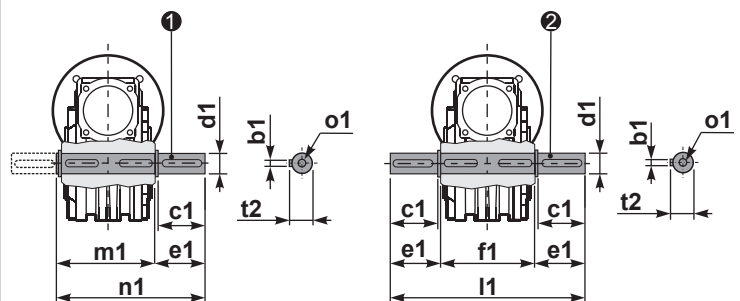

① kit cod. K085.5.028 type B

② kit cod. K085.5.029 type B

**R085FB...** Input shaft  
Albero in entrata

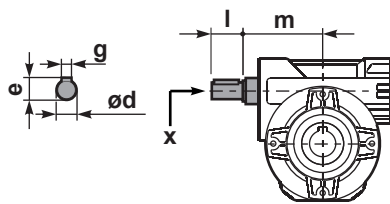

	ød	e	g	l	m	x	kit code
type B	25 h6	28	8	50	112	M8x20	① K085.5.007 PAM90 ② K085.5.008 PAM100
type S	24 h6	27	8	50	112	M8x20	① KS085.5.009 PAM90 ② KS085.5.011 PAM100

	b1	c1	d1	e1	f1	l1	m1	n1	t2	o1
type B	10	60	35 <sup>-0.005</sup> / <sub>-0.020</sub>	73.5	135	282	141	214.5	38	M10x23
type S	-	-	-	-	-	-	-	-	-	-

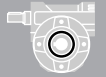

### QUICK SELECTION / Selezione veloce

input speed ( $n_1$ ) = 1400 min<sup>-1</sup>

Output Speed $n_2$ [min <sup>-1</sup> ]	Ratio $i$	Motor power $P_{1M}$ [kW]	Output torque $M_{2M}$ [Nm]	Service factor f.s.	Nominal power $P_{1R}$ [kW]	Nominal torque $M_{2R}$ [Nm]	Available B5 motor flanges					Available B14 motor flanges				Dynamic efficiency RD	Tooth Module [mm]	Ratios code	
							-C	-D	-E	-F	-G	-R	-T	-U	-V				
							71	80	90	100 112	132	80	90	100 112	132				
200	7	7.5	315	1.5	11.5	483		B	B				B	B			88	5.5	01
140	10	7.5	440	1.2	9.0	525		B	B				B	B			86	5.4	02
88	16	5.5	492	1.1	6.0	536		B	B				B	B			82	5.3	03
70	20	4.0	447	1.2	4.9	546		B	B				B	B			82	4.5	04
61	23	3.0	377	1.4	4.1	515		B	B				B	B			80	3.9	05
47	30	3.0	467	1.4	4.2	651		B	B				B	B			76	5.6	06
37	38	3.0	583	1.1	3.3	641		B	B				B	B			75	4.7	07
31	45	2.2	493	1.2	2.7	599		B	B				B	B			73	4.0	08
26	53	2.2	557	1.1	2.5	620		B	B				B	B			70	3.5	09
22	64	1.5	452	1.2	1.8	536	B	B					B				69	2.9	10
16.7	84	1.1	410	1.2	1.3	494	B	B					B				65	2.2	11
14.1	99	1.1	446	1.1	1.2	483	B	B					B				60	1.9	12

**Motor Flanges Available**  
Flange Motore Disponibili

**B) Supplied with Reduction Bushing**  
Fornito con Bussola di Riduzione

**B) Available on Request without reduction bushing**  
Disponibile a Richiesta senza Bussola di Riduzione

**C) Motor Flange Holes Position**  
Posizione Fori Flangia Motore

**EN** Unit 110 is supplied without lubricant and equipped with a breather, level and drain plugs. User can add mineral oil keeping existing plugs. Should the user wish to fill it with synthetic oil, it is recommended to replace the existing plugs with a closed plug. See table 1 for lubrication and recommended quantity. In table 2 please see possible radial loads and axial loads on the gearbox.

**I** Il riduttore tipo 110 è fornito privo di lubrificazione con tappi di sfiato, livello e scarico olio. L'utente può immettere olio minerale mantenendo i tappi esistenti. Se immetterà olio sintetico, dovrà sostituire i tappi esistenti con altri tipo chiuso. Tab.1 per oli e quantità consigliati. Tab.2 carichi radiali e assiali applicabili al riduttore.

**D** Das Getriebe der Baugröße 110 wird ohne Schmiermittel geliefert. Es ist jedoch mit Einfüllschraube, Überdruckventil und Ablassschraube ausgerüstet. Das benötigte mineralische Öl kann über die Einfüllschraube eingefüllt werden. Sollte synthetisches Öl bevorzugt werden, so ist sind das eingebaute Überdruckventil durch eine geschlossenen Schraube zu ersetzen. In Tabelle 1 ist die Schmiermenge und das empfohlene Schmiermittel angegeben. In Tabelle 2 sind die zulässigen Radial - und Axialbelastungen des Getriebes aufgeführt.

**F** Le réducteur de type 110 est fourni sans lubrification et avec un bouchon de remplissage, de niveau et d'évacuation de l'huile. L'utilisateur peut y verser de l'huile minérale en conservant les bouchons existants. S'il y versera de l'huile synthétique, il devra substituer les bouchons existants avec d'autres bouchons de type fermé. Voir tableau 1 concernant les huiles et les quantités conseillées. Voir tableau 2 concernant les charges radiales et axiales applicables au réducteur.

**E** El reductor tamaño 110 se suministra sin lubricante, provisto de tapones de respiración, nivel y descarga de aceite. El usuario puede utilizar aceite mineral, manteniendo los tapones existentes. Si prefiere utilizar aceite sintético deberá sustituir los tapones existentes por tapones ciegos. La prerreducción se suministra con tapones ciegos, lubricado de por vida con aceite sintético. Ver tabla 1, para cantidades y aceites recomendados. En la tabla 2, se encuentran las cargas radiales y axiales admitidas por el reductor.

B3	B6	B7	B8	V5	V6
2.00 LT	1.35 LT	1.35 LT	2.00LT	2.00 LT	2.00LT

**AGIP Blasias 460**

For all details on lubrication and plugs check our website [tab. 1](#)  
Per maggiori dettagli su lubrificazione e tappi olio vedi il nostro sito web

### RADIAL AND AXIAL LOADS

**Output shaft**  
Albero di uscita

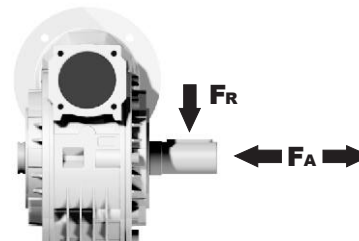

$n_2$ [min <sup>-1</sup> ]	FA [N]	FR [N]
200	600	2900
150	700	3300
100	750	3600
75	800	4000
50	920	4600
25	1200	6000
15	1400	7000

**Input shaft**  
albero in entrata

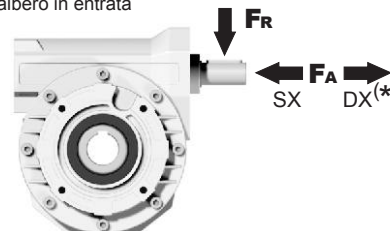

$n_1$ [min <sup>-1</sup> ]	FA [N]	FR [N]
1400	228	1140

**\*Strong axial loads in the DX direction are not allowed.**  
Non sono consentiti forti carichi assiali con direzione DX

tab. 2

**P110FB...** Basic wormbox  
Riduttore base

Gearbox weight  
peso riduttore **35.00 kg**

M. flanges	Kit code	øF	A
<b>71B5</b>	K023.4.041	160	135.5
<b>80/90B5</b>	K023.4.042	200	137.5
<b>100/112B5</b>	K023.4.043	250	146.5
<b>132B5</b>	-	300	187
<b>80B14</b>	K085.4.046	120	137.5
<b>90B14</b>	K085.4.045	140	137.5
<b>100/112B14</b>	K023.4.041	160	135.5
<b>132B14</b>	-	200	187

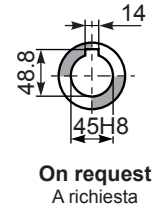
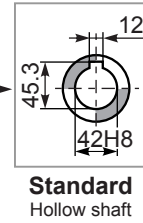
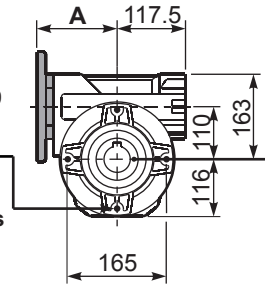
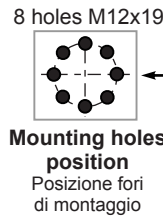
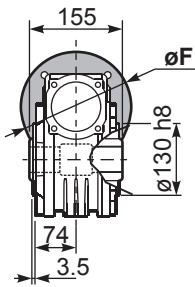

**P110PA...** Feet  
Piedini

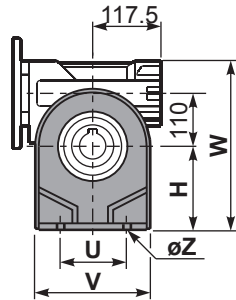
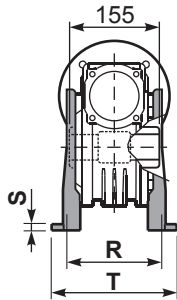

**P110PB...** Feet  
Piedini

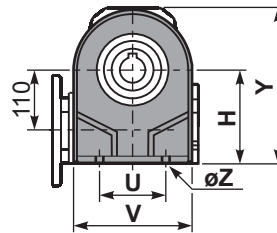

**P110PV...** Feet  
Piedini

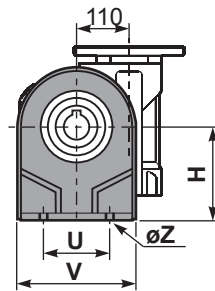

	H	R	S	T	U	V	Y	W	øZ	kit code
type B	170	180	22	224	200	240	286	333	ø13	K110.9.022
type S	172	160	8	204	200	240	288	335	ø14	KS110.9.023

**P110FC...** Output flange  
Flangia uscita

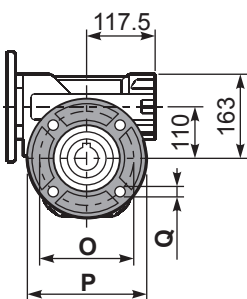
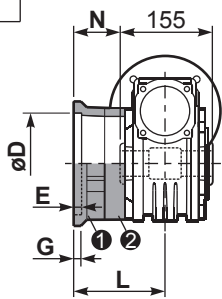

type B	øD	E	G	L	N	O	P	Q	kit code
<b>FC</b>	170 <sup>+0.083</sup> / <sub>+0.043</sub>	11	16.5	131.5	54	230	270	13	1 K110.9.010 2 -
<b>FL</b>	170 <sup>+0.083</sup> / <sub>+0.043</sub>	11	16.5	179.5	102	230	270	13	1 K110.9.011 2 -
type S	øD	E	G	L	N	O	P	Q	kit code
<b>F1</b>	180 <sup>+0.040</sup> / <sub>0</sub>	5	18	150	72.5	215	250	15	1 KS110.9.014 2 -
<b>F2</b>	170 <sup>+0.083</sup> / <sub>+0.043</sub>	9.5	15	178	100.5	230	270	13	1 KS110.9.012 2 -
<b>F3</b>	180 <sup>+0.040</sup> / <sub>0</sub>	5	18	130	52.5	215	250	15	1 KS110.9.013 2 -

**P110BR...** Reaction arm  
Braccio di reazione

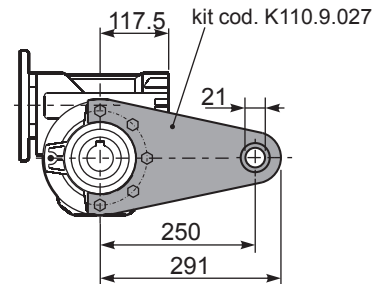
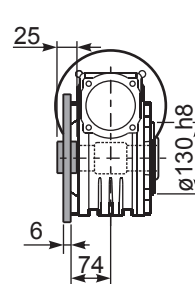

**P110....S...** Single Shaft  
Albero lento semplice

**P110....D...** Double Shaft  
Albero lento bisp.

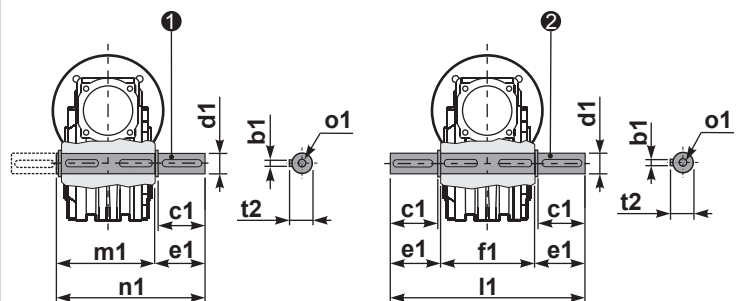

1 kit cod. K110.5.028 type B

2 kit cod. K110.5.029 type B

**R110FB...** Input shaft  
Albero in entrata

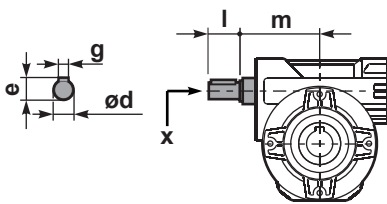

	ød	e	g	l	m	x	kit code
type B	25 h6	28	8	50	131.5	M8x20	1 K085.5.007 PAM90 2 K085.5.008 PAM100
type S	24 h6	27	8	50	131.5	M8x20	1 KS085.5.009 PAM90 2 KS085.5.011 PAM100

	b1	c1	d1	e1	f1	l1	m1	n1	t2	o1
type B	12	75	42 <sup>-0.005</sup> / <sub>-0.020</sub>	96.5	155	348	163.5	260	45	M12x32
type S	-	-	-	-	-	-	-	-	-	-

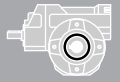

#### QUICK SELECTION / Selezione veloce

input speed ( $n_1$ ) = 1400 min<sup>-1</sup>

Output Speed $n_2$ [min <sup>-1</sup> ]	Ratio $i$	Motor power $P_{1M}$ [kW]	Output torque $M_{2M}$ [Nm]	Service factor f.s.	Nominal power $P_{1R}$ [kW]	Nominal torque $M_{2R}$ [Nm]	Available B5 motor flanges			Available B14 motor flanges		Dynamic efficiency <b>RD</b>	Tooth Module  [mm]	Ratios code
							-A	-B	-C	-P	-Q			
							56	63	71	63	71			
47	<b>30.1</b>	0.25	38	1.4	<b>0.36</b>	<b>55</b>				<b>C</b>		74	2.2	01
33	<b>43.0</b>	0.25	53	1.0	<b>0.26</b>	<b>55</b>				<b>C</b>		72	2.2	02
23	<b>60.2</b>	0.25	62	0.9	<b>0.22</b>	<b>55</b>				<b>C</b>		60	2.4	03
15.5	<b>90.3</b>	0.12	42	1.3	<b>0.16</b>	<b>55</b>				<b>C</b>		57	1.6	04
11.6	<b>120</b>	0.12	52	1.1	<b>0.13</b>	<b>55</b>				<b>C</b>		53	2.5	05
8.8	<b>159</b>	0.12	64	0.9	<b>0.10</b>	<b>55</b>				<b>C</b>		49	1.8	06
7.1	<b>198</b>	0.12*	55	<0.8	<b>0.09</b>	<b>55</b>				<b>C</b>		47	1.5	07
5.4	<b>258</b>	0.12*	55	<0.8	<b>0.07</b>	<b>55</b>				<b>C</b>		45	1.2	08
4.7	<b>301</b>	0.12*	39	<0.8	<b>0.05</b>	<b>39</b>				<b>C</b>		40	1.0	09
3.2	<b>439</b>	0.12*	39	<0.8	<b>0.04</b>	<b>39</b>				<b>C</b>		36	0.72	10

**A) Motor Flanges Available**  
Flange Motore Disponibili

**B) Supplied with Reduction Bushing**  
Fornito con Bussola di Riduzione

**Available on Request without reduction bushing**  
Disponibile a Richiesta senza Bussola di Riduzione

**C) Motor Flange Holes Position**  
Posizione Fori Flangia Motore

\* Power higher than the maximum one which can be supported by the gearbox. Select according to the torque  $M_{2R}$   
Potenza superiore a quella massima sopportabile dal riduttore. Selezionare in base al momento torcente  $M_{2R}$

**EN** Unit **P45** is supplied with synthetic oil, providing "long life" lubrication. For mounting position V5-V6 please contact us. See table 1 for lubrication and recommended quantity. In table 2 please see possible radial loads and axial loads on the gearbox.

**I** Il riduttore tipo **P45** viene fornito lubrificato a vita con olio sintetico. Per posizioni V5-V6 contattare il ns. servizio tecnico. Vedi tab.1 per oli e quantità consigliati. In tab.2 sono presenti i carichi radiali e assiali applicabili al riduttore.

**D** Für die Lebensdauerschmierung ist das Getriebe der Größe **P45** mit synthetischem Öl befüllt. Bei Einbaulage V5 oder V6 bitten wir um Rücksprache. In Tabelle 1 ist die Schmiermenge und das empfohlene Schmiermittel angegeben. In Tabelle 2 sind die zulässigen Radial- und Axialbelastungen des Getriebes aufgeführt.

**F** Le réducteur de type **P45** est fourni lubrifié à vie avec de l'huile synthétique. Concernant les positions V5.V6, contactez notre service d'assistance technique. Voir tableau 1 concernant les huiles et les quantités conseillées. Les charges radiales et axiales applicables au réducteur sont précisées dans le tableau 2.

**E** El reductor tamaño **P45** se suministra, lubricado de por vida con aceite sintético. Para las posiciones V5 y V6 contactar con nuestro servicio técnico. Ver tabla 1, para cantidades y aceites recomendados. En la tabla 2, se encuentran las cargas radiales y axiales admitidas por el reductor.

#### LUBRICATION P45 Oil

Common lubrication 0.17 l (A + B).



**AGIP** Telium VSF 320

**SHELL** Omala S4 WE 320

For all details on lubrication and plugs check our website **tab. 1**  
Per maggiori dettagli su lubrificazione e tappi olio vedi il nostro sito web

#### RADIAL AND AXIAL LOADS

**Output shaft**  
Albero di uscita

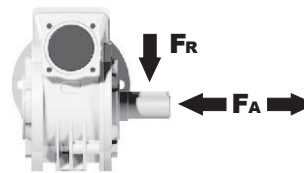

$n_2$ [min <sup>-1</sup> ]	$F_A$ [N]	$F_R$ [N]
75	240	1200
50	260	1400
25	300	1800
15-6	400	2000

**Input shaft**  
albero in entrata

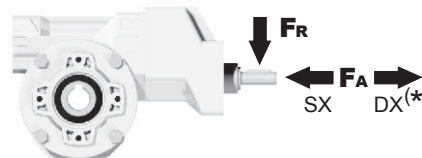

$n_1$ [min <sup>-1</sup> ]	$F_A$ [N]	$F_R$ [N]
1400	44	220

\*Strong axial loads in the DX direction are not allowed.  
Non sono consentiti forti carichi assiali con direzione DX

tab. 2

PP45**FB**... Basic wormbox  
Riduttore base

Gearbox weight  
peso riduttore **3.20 kg**

M. flanges	Kit code	øF	A
56B5	K050.4.046	120	137.5
63B5	K050.4.041	138	139.5
71B5	K050.4.042	160	137
63B14	K050.4.047	90	139.5
71B14	K050.4.045	105	137

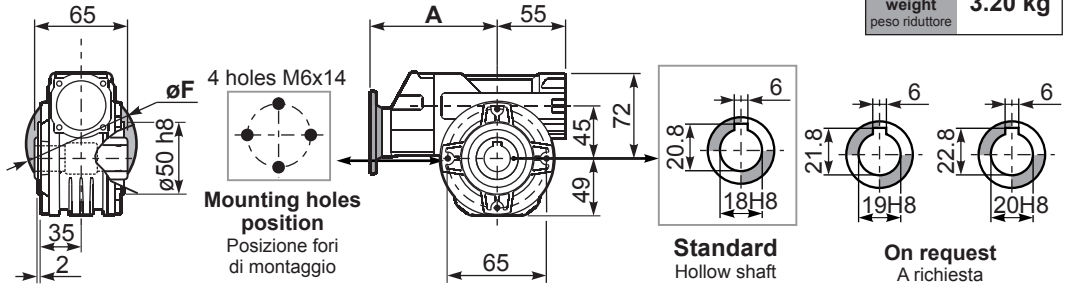

PP45**PA**... Feet  
Piedini

PP45**PB**... Feet  
Piedini

PP45**PV**... Feet  
Piedini

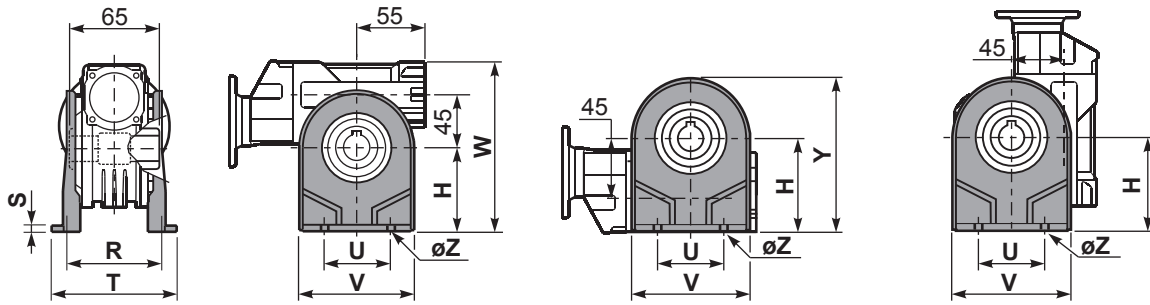

	H	R	S	T	U	V	Y	W	øZ	kit code
type B	72	81	3	100	52	98	121	144	ø10.5	K045.9.022
type S	71	84	8	100	70	90	120	143	ø8	KS045.9.023

PP45**FC**... Output flange  
Flangia uscita

PP45**BR**... Reaction arm  
Braccio di reazione

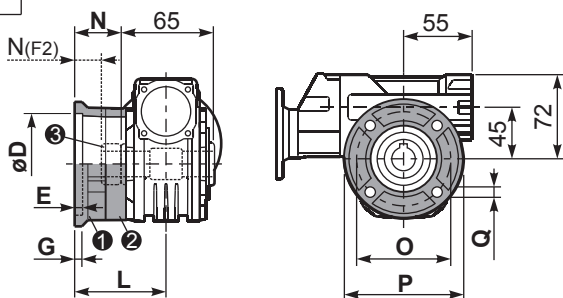

type B	øD	E	G	L	N	O	P	Q	kit code
FC	60 <sup>+0.15</sup> / <sub>-0.05</sub>	9	9	60.5	28	87	110	8.5	① K045.9.010 ② -
FL	60 <sup>+0.15</sup> / <sub>-0.05</sub>	9	9	90.5	58	87	110	8.5	① K045.9.010 ② K045.0.200

  

type S	øD	E	G	L	N	O	P	Q	kit code
F1	95 <sup>+0.20</sup> / <sub>-0.15</sub>	4	11	73.5	41	115	140	9	① KS045.9.013 ② -
F2	60 <sup>+0.15</sup> / <sub>-0.05</sub>	9	9	60.5	19	87	110	8.5	① KS045.9.010 ② S045.0.204
F3	80 <sup>+0.03</sup> / <sub>-0.00</sub>	3	8	51.5	19	100	120	9	① KS045.9.014 ② -

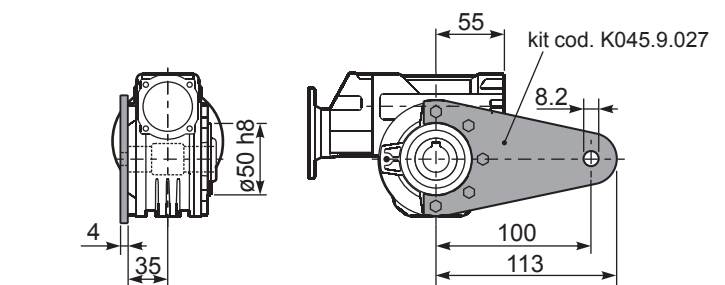

PP45.....**S**... Single Shaft  
Albero lento semplice

PP45.....**D**... Double Shaft  
Albero lento bisp.

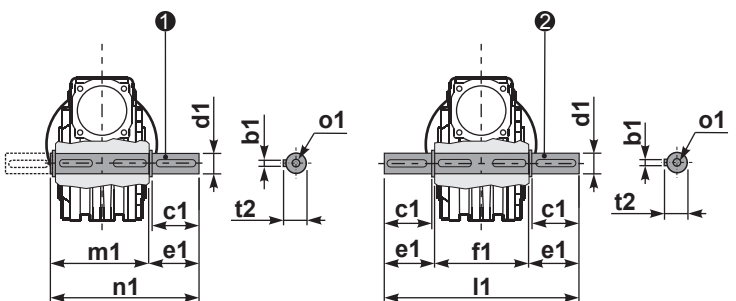

- ① kit cod. K045.5.028 type B  
kit cod. KS045.5.030 type S
- ② kit cod. K045.5.029 type B  
kit cod. KS045.5.031 type S

RP45**FB**... Input shaft  
Albero in entrata

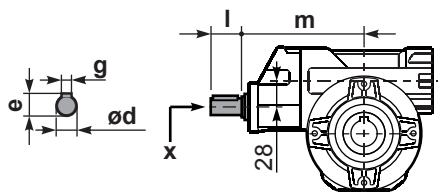

	ød	e	g	l	m	x
type B	14 h6	16	5	25	131	M5x13
type S	-	-	-	-	-	-

	b1	c1	d1	e1	f1	l1	m1	n1	t2	o1
type B	6	32	18 <sup>-0.005</sup> / <sub>-0.020</sub>	43	65	151	70	113	20.5	M6x18
type S	6	40	19 <sup>-0.005</sup> / <sub>-0.020</sub>	58.8	65	182	70	128.5	21.5	M8x20

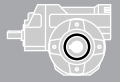

#### QUICK SELECTION / Selezione veloce

input speed ( $n_1$ ) = 1400 min<sup>-1</sup>

Output Speed $n_2$ [min <sup>-1</sup> ]	Ratio $i$	Motor power $P_{1M}$ [kW]	Output torque $M_{2M}$ [Nm]	Service factor f.s.	Nominal power $P_{1R}$ [kW]	Nominal torque $M_{2R}$ [Nm]	Available B5 motor flanges			Available B14 motor flanges		Dynamic efficiency <b>RD</b>	Tooth Module  [mm]	 Ratios code
							-A	-B	-C	-P	-Q			
							56	63	71	63	71			
47	<b>30.1</b>	0.37	58	1.3	<b>0.49</b>	77				C		76	2.5	01
33	<b>43.0</b>	0.25	55	1.4	<b>0.35</b>	77				C		75	2.4	02
23	<b>60.2</b>	0.25	71	1.1	<b>0.27</b>	77				C		69	2.6	03
18.1	<b>77.4</b>	0.25	81	1.1	<b>0.27</b>	88				C		61	2.0	04
12.5	<b>112</b>	0.18	84	1.1	<b>0.19</b>	88				C		61	2.7	05
9.0	<b>155</b>	0.12	71	1.2	<b>0.15</b>	88				C		56	2.1	06
7.6	<b>185</b>	0.12	74	1.0	<b>0.12</b>	77				C		49	1.8	07
5.4	<b>258</b>	0.12*	77	<0.8	<b>0.09</b>	77				C		47	1.3	08
4.8	<b>292</b>	0.12*	66	<0.8	<b>0.08</b>	66				C		44	1.2	09
4.1	<b>344</b>	0.12*	44	<0.8	<b>0.05</b>	44				C		40	1.0	10
3.3	<b>430</b>	0.12*	44	<0.8	<b>0.04</b>	44				C		36	0.8	11

**A** Motor Flanges Available  
Flange Motore Disponibili

**B** Supplied with Reduction Bushing  
Fornito con Bussola di Riduzione

**B** Available on Request without reduction bushing  
Disponibile a Richiesta senza Bussola di Riduzione

**C** Motor Flange Holes Position  
Posizione Fori Flangia Motore

\* Power higher than the maximum one which can be supported by the gearbox. Select according to the torque  $M_{2R}$   
Potenza superiore a quella massima sopportabile dal riduttore. Selezionare in base al momento torcente  $M_{2R}$

**EN** Unit **P50** is supplied with synthetic oil, providing "long life" lubrication. For mounting position V5-V6 please contact us. See table 1 for lubrication and recommended quantity. In table 2 please see possible radial loads and axial loads on the gearbox.

**I** Il riduttore tipo **P50** viene fornito lubrificato a vita con olio sintetico. Per posizioni V5-V6 contattare il ns. servizio tecnico. Vedi tab.1 per oli e quantità consigliati. In tab.2 sono presenti i carichi radiali e assiali applicabili al riduttore.

**D** Für die Lebensdauerschmierung ist das Getriebe der Größe **P50** mit synthetischem Öl befüllt. Bei Einbaulage V5 oder V6 bitten wir um Rücksprache. In Tabelle 1 ist die Schmiermenge und das empfohlene Schmiermittel angegeben. In Tabelle 2 sind die zulässigen Radial- und Axialbelastungen des Getriebes aufgeführt.

**F** Le réducteur de type **P50** est fourni lubrifié à vie avec de l'huile synthétique. Concernant les positions V5.V6, contactez notre service d'assistance technique. Voir tableau 1 concernant les huiles et les quantités conseillées. Les charges radiales et axiales applicables au réducteur sont précisées dans le tableau 2.

**E** El reductor tamaño **P50** se suministra, lubricado de por vida con aceite sintético. Para las posiciones V5 y V6 contactar con nuestro servicio técnico. Ver tabla 1, para cantidades y aceites recomendados. En la tabla 2, se encuentran las cargas radiales y axiales admitidas por el reductor.

**LUBRICATION P50 Oil**  
Common lubrication 0.26 l (A + B).



<b>AGIP</b> Telium VSF 320	<b>SHELL</b> Omala S4 WE 320
----------------------------	------------------------------

For all details on lubrication and plugs check our website tab. 1  
Per maggiori dettagli su lubrificazione e tappi olio vedi il nostro sito web

### RADIAL AND AXIAL LOADS

**Output shaft**  
Albero di uscita

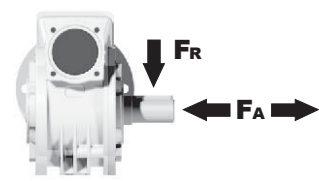

$n_2$ [min <sup>-1</sup> ]	FA [N]	FR [N]
75	340	1700
50	380	1900
25	480	2500
15-6	560	2800

**Input shaft**  
albero in entrata

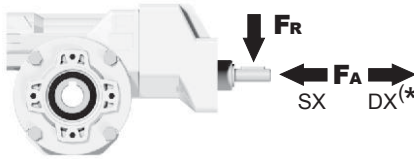

$n_1$ [min <sup>-1</sup> ]	FA [N]	FR [N]
1400	44	220

\*Strong axial loads in the DX direction are not allowed.  
Non sono consentiti forti carichi assiali con direzione DX

tab. 2



**PP50FB...** Basic wormbox  
Riduttore base

Gearbox weight  
peso riduttore **3.80 kg**

M. flanges	Kit code	øF	A
<b>56B5</b>	K050.4.046	120	142
<b>63B5</b>	K050.4.041	138	144
<b>71B5</b>	K050.4.042	160	141.5
<b>63B14</b>	K050.4.047	90	144
<b>71B14</b>	K050.4.045	105	141.5

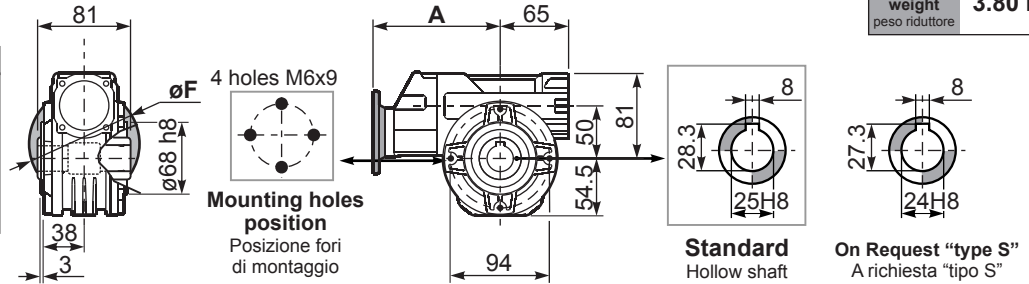

**PP50PA...** Feet  
Piedini

**PP50PB...** Feet  
Piedini

**PP50PV...** Feet  
Piedini

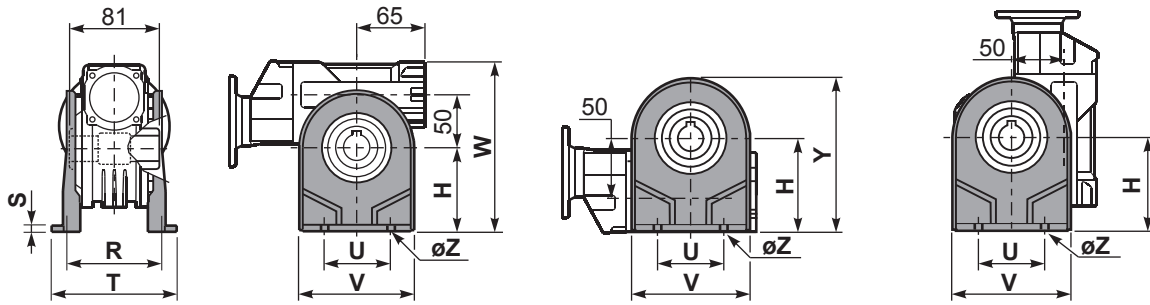

	H	R	S	T	U	V	Y	W	øZ	kit code
type B	82	98.5	3.5	123	63	113	138.5	163	ø10.5	K050.9.022
type S	85	96	10	114	85	110	139.5	166	ø10	KS050.9.023

**PP50FC...** Output flange  
Flangia uscita

**PP50BR...** Reaction arm  
Braccio di reazione

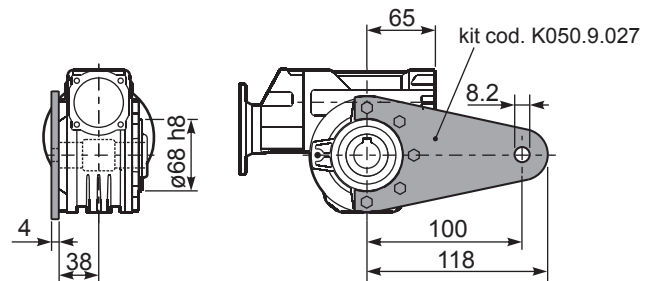
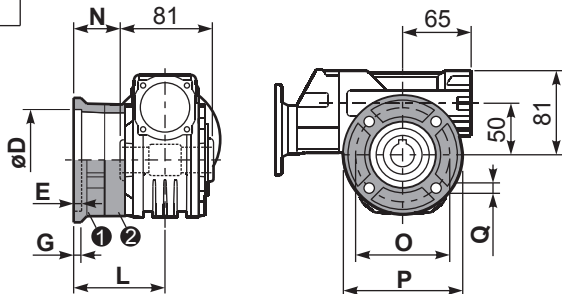

type B	øD	E	G	L	N	O	P	Q	kit code
<b>FC</b>	70 <sup>+0.20</sup> / <sub>+0.15</sub>	9	12	85	44.5	90	123	10.5	① K050.9.010 ② -
<b>FL</b>	70 <sup>+0.20</sup> / <sub>+0.15</sub>	9	12	114.5	74	90	123	10.5	① K050.9.010 ② K050.0.200

type S	øD	E	G	L	N	O	P	Q	kit code
<b>F1</b>	110 <sup>+0.20</sup> / <sub>+0.15</sub>	4	11	83.5	43	130	160	10	① KS050.9.012 ② -
<b>F2</b>	70 <sup>+0.20</sup> / <sub>+0.15</sub>	9	12	76.5	36	90	123	10.5	① KS050.9.014 ② -
<b>F3</b>	95 <sup>+0.035</sup> / <sub>0</sub>	4	10	66.5	26	115	140	10	① KS050.9.013 ② -

**PP50.....S...** Single Shaft  
Albero lento semplice

**PP50.....D...** Double Shaft  
Albero lento bisp.

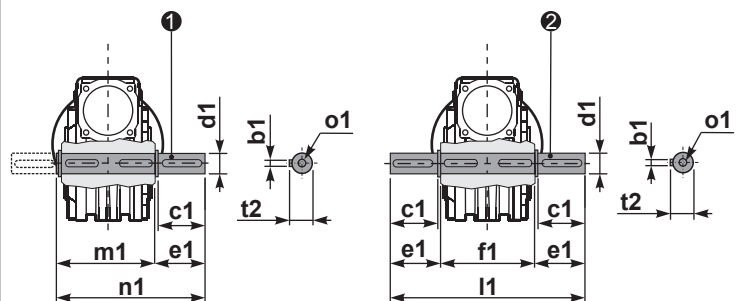

- ① kit cod. K050.5.028 type B  
kit cod. KS050.5.030 type S
- ② kit cod. K050.5.029 type B  
kit cod. KS050.5.031 type S

**RP50FB...** Input shaft  
Albero in entrata

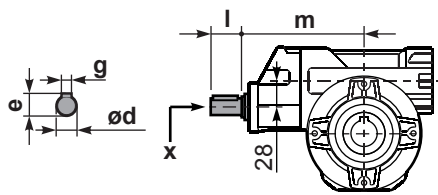

	ød	e	g	l	m	x
type B	14 h6	16	5	25	135.5	M5x13
type S	-	-	-	-	-	-

	b1	c1	d1	e1	f1	l1	m1	n1	t2	o1
type B	8	52	25 <sup>-0.005</sup> / <sub>-0.020</sub>	59.5	81	200	86.5	146	28	M8x20
type S	8	50	24 <sup>-0.005</sup> / <sub>-0.020</sub>	68.8	81	218	86.5	155	27	M8x20

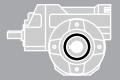

#### QUICK SELECTION / Selezione veloce

input speed ( $n_1$ ) = 1400 min<sup>-1</sup>

	Output Speed $n_2$ [min <sup>-1</sup> ]	Ratio $i$	Motor power $P_{1M}$ [kW]	Output torque $M_{2M}$ [Nm]	Service factor f.s.	Nominal power $P_{1R}$ [kW]	Nominal torque $M_{2R}$ [Nm]	Available B5 motor flanges				Available B14 motor flanges				Dynamic efficiency <b>RD</b>	Tooth Module [mm]	Ratios code
								-B	-C	-D	-E	-P	-Q	-R	-T			
								63	71	80	90	63	71	80	90			
IEC 90 - 80 - 71	47	<b>29.9</b>	0.75	113	1.5	<b>1.1</b>	<b>165</b>						C	C		74	2.6	01
	37	<b>37.7</b>	0.75	141	1.2	<b>0.88</b>	<b>165</b>						C	C		73	2.0	02
	30	<b>47.1</b>	0.75	169	1.1	<b>0.83</b>	<b>187</b>						C	C		70	3.2	03
	25	<b>56.6</b>	0.55	136	1.4	<b>0.76</b>	<b>187</b>						C	C		64	2.7	04
	19.8	<b>70.7</b>	0.55	164	1.1	<b>0.63</b>	<b>187</b>						C	C		62	2.1	05
	15.9	<b>87.8</b>	0.37	162	1.2	<b>0.43</b>	<b>187</b>						C	C		73	2.6	06
	12.6	<b>111.0</b>	0.37	199	0.9	<b>0.35</b>	<b>187</b>						C	C		71	2.0	07
IEC 71 - 63	10.1	<b>139</b>	0.37	234	0.8	<b>0.30</b>	<b>187</b>						C			67	3.2	08
	8.4	<b>166</b>	0.25	173	1.1	<b>0.27</b>	<b>187</b>						C			61	2.7	09
	6.7	<b>208</b>	0.18	151	1.1	<b>0.20</b>	<b>165</b>						C			59	2.1	10
	4.5	<b>310</b>	0.12	129	1.3	<b>0.15</b>	<b>165</b>						C			51	1.5	11
	3.8	<b>370</b>	0.12	145	1.1	<b>0.14</b>	<b>165</b>						C			48	1.3	12
	3.2	<b>434</b>	0.12	149	0.9	<b>0.11</b>	<b>138</b>						C			42	1.1	13

Motor Flanges Available Flange Motore Disponibili    
 B) Supplied with Reduction Bushing Fornito con Bussola di Riduzione    
 B) Available on Request without reduction bushing Disponibile a Richiesta senza Bussola di Riduzione    
 C) Motor Flange Holes Position Posizione Fori Flangia Motore

**EN** Unit **P63** is supplied with synthetic oil, providing "long life" lubrication. For mounting position V5-V6 please contact us. See table 1 for lubrication and recommended quantity. In table 2 please see possible radial loads and axial loads on the gearbox.

**I** Il riduttore tipo **P63** viene fornito lubrificato a vita con olio sintetico. Per posizioni V5-V6 contattare il ns. servizio tecnico. Vedi tab.1 per oli e quantità consigliati. In tab.2 sono presenti i carichi radiali e assiali applicabili al riduttore.

**D** Für die Lebensdauerschmierung ist das Getriebe der Größe **P63** mit synthetischem Öl befüllt. Bei Einbaulage V5 oder V6 bitten wir um Rücksprache. In Tabelle 1 ist die Schmiermenge und das empfohlene Schmiermittel angegeben. In Tabelle 2 sind die zulässigen Radial- und Axialbelastungen des Getriebes aufgeführt.

**F** Le réducteur de type **P63** est fourni lubrifié à vie avec de l'huile synthétique. Concernant les positions V5.V6, contactez notre service d'assistance technique. Voir tableau 1 concernant les huiles et les quantités conseillées. Les charges radiales et axiales applicables au réducteur sont précisées dans le tableau 2.

**E** El reductor tamaño **P63** se suministra, lubricado de por vida con aceite sintético. Para las posiciones V5 y V6 contactar con nuestro servicio técnico. Ver tabla 1, para cantidades y aceites recomendados. En la tabla 2, se encuentran las cargas radiales y axiales admitidas por el reductor.

**LUBRICATION P63 Oil**

For B3-V5-V6 separate lubrication for A ( 0.40 l ) B ( 0.08 l ) , for B6-B7-B8 common lubrication 0.38 l ( A + B ).

AGIP Telium VSF 320    
 SHELL Omala S4 WE 320

For all details on lubrication and plugs check our website **tab. 1**  
Per maggiori dettagli su lubrificazione e tappi olio vedi il nostro sito web

#### RADIAL AND AXIAL LOADS

**Output shaft**  
Albero di uscita

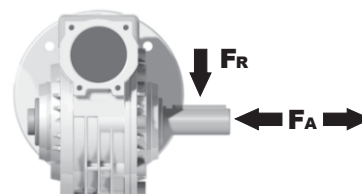

$n_2$ [min <sup>-1</sup> ]	FA [N]	FR [N]
75	500	2500
50	600	3000
25	700	3800
15-6	800	4000

**Input shaft**  
albero in entrata

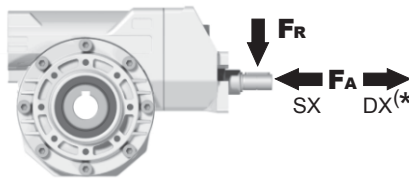

$n_1$ [min <sup>-1</sup> ]	FA [N]	FR [N]
1400	61	305

**\*Strong axial loads in the DX direction are not allowed.**  
Non sono consentiti forti carichi assiali con direzione DX

tab. 2

PP63**FB**... Basic wormbox  
Riduttore base

Gearbox weight	29.9+111	139+434
peso riduttore	7.30	7.80
	Kg	Kg

M.flange	Kit code	øF	A
71B5	K063.4.042	160	176.5
80/90B5	K063.4.043	200	178.5
71B14	K063.4.047	105	176.5
80B14	K063.4.046	120	178.5
90B14	K063.4.041	140	178.5
<b>139+434</b>			
63B5	K050.4.041	138	162.5
71B5	K050.4.042	160	160
63B14	K050.4.047	90	162.5
71B14	K050.4.045	105	160

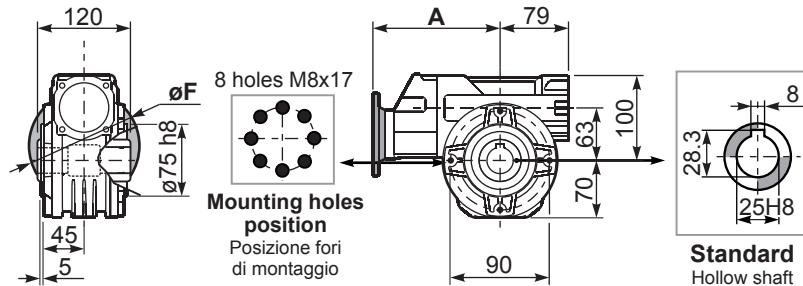

PP63**PA**... Feet  
Piedini

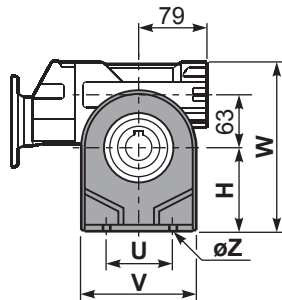
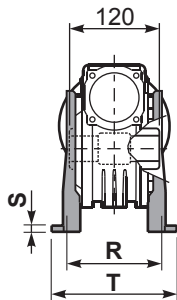

PP63**PB**... Feet  
Piedini

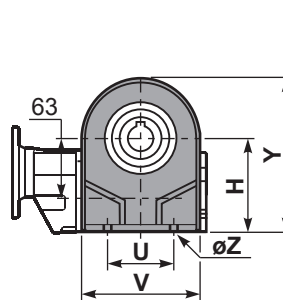

PP63**PV**... Feet  
Piedini

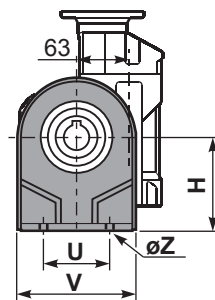

	H	R	S	T	U	V	Y	W	øZ	kit code
type B	100	111	4	144	95	133	170	200	ø10.5	K063.9.022
type S	-	-	-	-	-	-	-	-	-	-

PP63**FC**... Output flange  
Flangia uscita

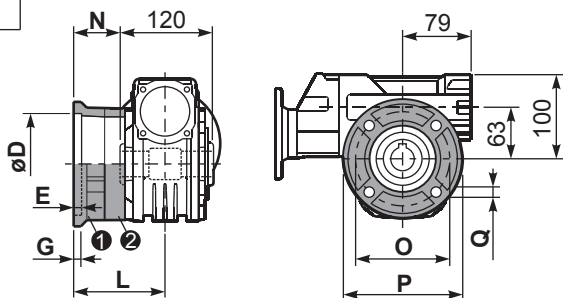

type B	øD	E	G	L	N	O	P	Q	kit code
FC	115 <sup>+0.20</sup> / <sub>+0.15</sub>	7	13	86	26	150	175	11	1 K063.9.010 2 -
FL	115 <sup>+0.20</sup> / <sub>+0.15</sub>	7	13	116	56	150	175	11	1 K063.9.010 2 K063.0.200
type S	øD	E	G	L	N	O	P	Q	kit code
F1	130 <sup>+0.20</sup> / <sub>+0.15</sub>	7	13	102	42	165	200	13	1 KS070.9.013 2 -
F2	115 <sup>+0.20</sup> / <sub>+0.15</sub>	7	13	116	56	150	175	11	1 KS063.9.013 2 -
F3	110 <sup>+0.035</sup> / <sub>0</sub>	5	11	82	22	130	160	10	1 KS063.9.011 2 -

PP63**BR**... Reaction arm  
Braccio di reazione

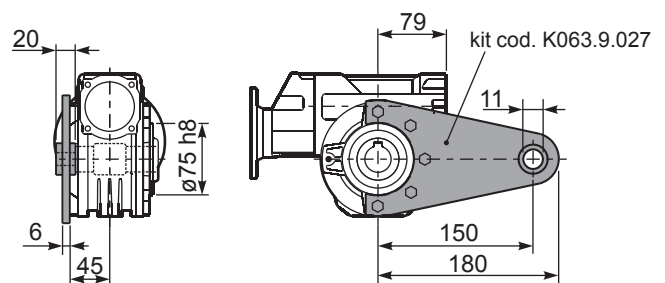

PP63.....**S**... Single Shaft  
Albero lento semplice

PP63.....**D**... Double Shaft  
Albero lento bisp.

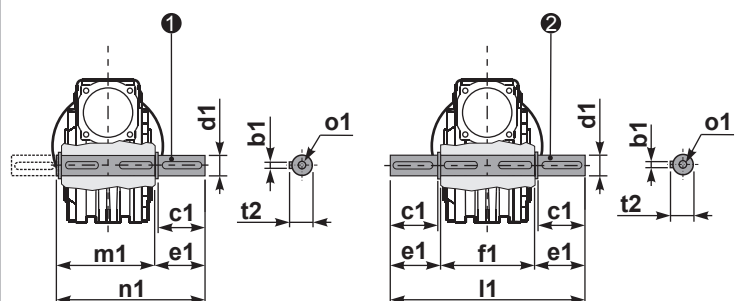

1 kit cod. K063.5.028 type B

2 kit cod. K063.5.029 type B

RP63**FB**... Input shaft  
Albero in entrata

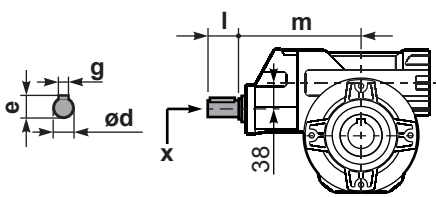

	ød	e	g	l	m	x	
29.9+111	19 h6	21.5	6	35	169.4	M6x16	C40.5.062
139+434	14 h6	16	5	25	154.2	M5x13	C35.5.061

	b1	c1	d1	e1	f1	l1	m1	n1	t2	o1
type B	8	60	25 <sup>-0.005</sup> / <sub>-0.020</sub>	63.2	120	246.4	126.8	190	28	M8x20
type S	-	-	-	-	-	-	-	-	-	-

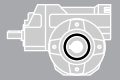

#### QUICK SELECTION / Selezione veloce

input speed (n<sub>1</sub>) = 1400 min<sup>-1</sup>

	Output Speed n <sub>2</sub> [min <sup>-1</sup> ]	Ratio i	Motor power P <sub>1M</sub> [kW]	Output torque M <sub>2M</sub> [Nm]	Service factor f.s.	Nominal power P <sub>1R</sub> [kW]	Nominal torque M <sub>2R</sub> [Nm]	Available B5 motor flanges				Available B14 motor flanges				Dynamic efficiency RD	Tooth Module [mm]	Ratios code
								-B	-C	-D	-E	-P	-Q	-R	-T			
								63	71	80	90	63	71	80	90			
IEC 90 - 80 - 71	47	29.9	0.75	113	1.6	1.20	182					C	C		74	2.6	01	
	37	37.7	0.75	141	1.3	0.97	182					C	C		73	2.0	02	
	30	47.1	0.75	169	1.2	0.91	206					C	C		70	3.2	03	
	25	56.6	0.75	185	1.1	0.83	206					C	C		64	2.7	04	
	19.8	70.7	0.55	162	1.3	0.70	206					C	C		61	2.1	05	
	15.9	87.8	0.37	160	1.4	0.51	218					C	C		72	2.6	06	
	12.6	111.0	0.37	196	1.1	0.41	218					C	C		70	2.0	07	
IEC 71 - 63	10.1	139	0.37	231	0.9	0.35	218					C			66	3.2	08	
	8.4	166	0.25	170	1.3	0.32	218					C			60	2.7	09	
	6.7	208	0.25	195	1.0	0.25	194					C			55	2.1	10	
	4.5	310	0.18	194	1.0	0.18	194					C			51	1.5	11	
	3.8	370	0.18	213	0.9	0.16	194					C			47	1.3	12	
	3.2	434	0.18*	143	<0.8	0.11	143					C			42	1.1	13	

**Motor Flanges Available**  
Flange Motore Disponibili

**B) Supplied with Reduction Bushing**  
Fornito con Bussola di Riduzione

**B) Available on Request without reduction bushing**  
Disponibile a Richiesta senza Bussola di Riduzione

**C) Motor Flange Holes Position**  
Posizione Fori Flangia Motore

\* Power higher than the maximum one which can be supported by the gearbox. Select according to the torque M<sub>2R</sub>  
Potenza superiore a quella massima sopportabile dal riduttore. Selezionare in base al momento torcente M<sub>2R</sub>

**EN** Unit P6A is supplied with synthetic oil, providing "long life" lubrication. For mounting position V5-V6 please contact us. See table 1 for lubrication and recommended quantity. In table 2 please see possible radial loads and axial loads on the gearbox.

**I** Il riduttore tipo P6A viene fornito lubrificato a vita con olio sintetico. Per posizioni V5-V6 contattare il ns. servizio tecnico. Vedi tab.1 per oli e quantità consigliati. In tab.2 sono presenti i carichi radiali e assiali applicabili al riduttore.

**D** Für die Lebensdauerschmierung ist das Getriebe der Größe P6A mit synthetischem Öl befüllt. Bei Einbaulage V5 oder V6 bitten wir um Rücksprache. In Tabelle 1 ist die Schmiermenge und das empfohlene Schmiermittel angegeben. In Tabelle 2 sind die zulässigen Radial- und Axialbelastungen des Getriebes aufgeführt.

**F** Le réducteur de type P6A est fourni lubrifié à vie avec de l'huile synthétique. Concernant les positions V5.V6, contactez notre service d'assistance technique. Voir tableau 1 concernant les huiles et les quantités conseillées. Les charges radiales et axiales applicables au réducteur sont précisées dans le tableau 2.

**E** El reductor tamaño P6A se suministra, lubricado de por vida con aceite sintético. Para las posiciones V5 y V6 contactar con nuestro servicio técnico. Ver tabla 1, para cantidades y aceites recomendados. En la tabla 2, se encuentran las cargas radiales y axiales admitidas por el reductor.

#### LUBRICATION P6A Oil

For B3-V5-V6 separate lubrication for A ( 0.40 l ) B ( 0.08 l ) , for B6-B7-B8 common lubrication 0.38 l ( A + B ).

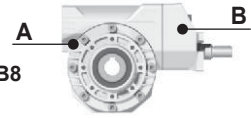

AGIP Telium VSF 320

SHELL Omala S4 WE 320

For all details on lubrication and plugs check our website **tab. 1**  
Per maggiori dettagli su lubrificazione e tappi olio vedi il nostro sito web

#### RADIAL AND AXIAL LOADS

##### Output shaft

Albero di uscita

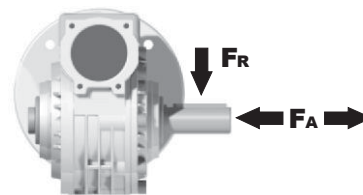

n <sub>2</sub> [min <sup>-1</sup> ]	FA [N]	FR [N]
75	500	2500
50	600	3000
25	700	3800
15-6	800	4000

##### Input shaft

albero in entrata

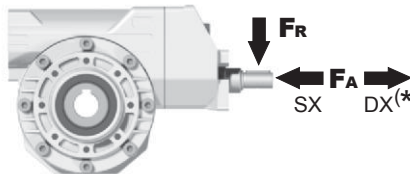

n <sub>1</sub> [min <sup>-1</sup> ]	FA [N]	FR [N]
1400	61	305

\*Strong axial loads in the DX direction are not allowed.  
Non sono consentiti forti carichi assiali con direzione DX

**tab. 2**

**PP6A<sup>FB</sup>...** Basic wormbox  
Riduttore base

Gearbox weight peso riduttore	29.9+111	139+434
	<b>7.30</b>	<b>7.80</b>
	<b>Kg</b>	<b>Kg</b>

M.flange	Kit code	øF	A
71B5	K063.4.042	160	176.5
80/90B5	K063.4.043	200	178.5
71B14	K063.4.047	105	176.5
80B14	K063.4.046	120	178.5
90B14	K063.4.041	140	178.5
<hr/>			
139+434			
63B5	K050.4.041	138	162.5
71B5	K050.4.042	160	160
63B14	K050.4.047	90	162.5
71B14	K050.4.045	105	160

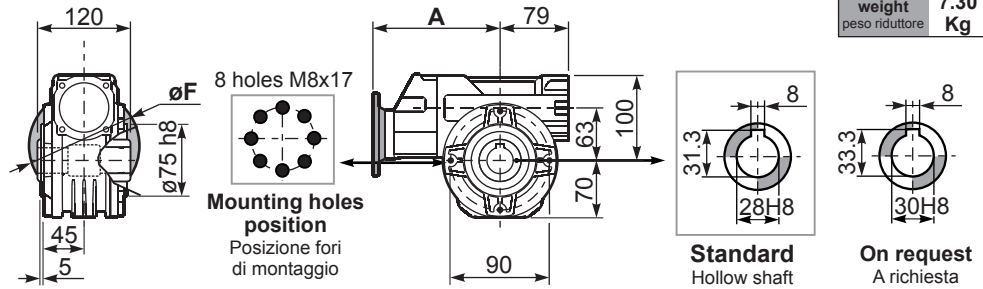

**PP6A<sup>PA</sup>...** Feet  
Piedini

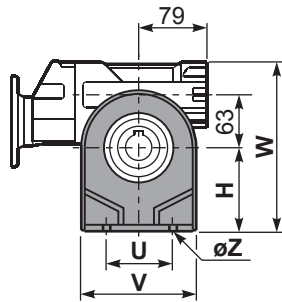
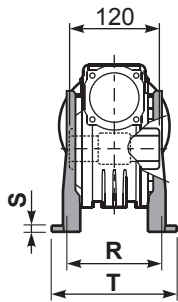

**PP6A<sup>PB</sup>...** Feet  
Piedini

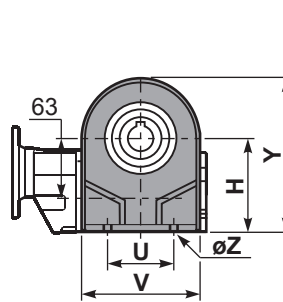

**PP6A<sup>PV</sup>...** Feet  
Piedini

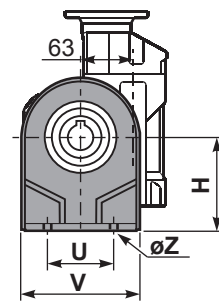

	H	R	S	T	U	V	Y	W	øZ	kit code
type B	115	115	12	142	120	156	185	215	ø11	K070.9.022
type S	-	-	-	-	-	-	-	-	-	-

**PP6A<sup>FC</sup>...** Output flange  
Flangia uscita

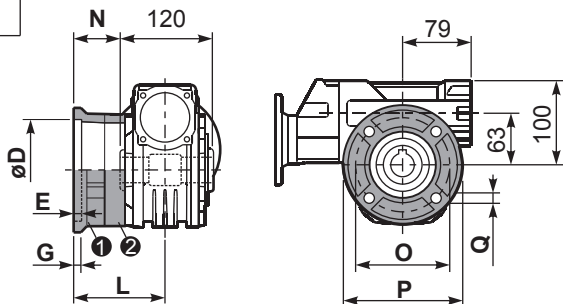

type B	øD	E	G	L	N	O	P	Q	kit code
FC	130 <sup>+0.20</sup> / <sub>+0.15</sub>	7	13	85	25	165	200	13	① K070.9.010 ② -
FL	130 <sup>+0.20</sup> / <sub>+0.15</sub>	7	13	111	51	165	200	13	① K070.9.010 ② K070.0.200
type S	øD	E	G	L	N	O	P	Q	kit code
F1	130 <sup>+0.20</sup> / <sub>+0.15</sub>	7	13	111	51	165	200	13	① KS070.9.014 ② -
F2	115 <sup>+0.20</sup> / <sub>+0.15</sub>	7	13	116	56	150	175	11	① KS063.9.013 ② -
F3	110 <sup>+0.035</sup> / <sub>0</sub>	5	13.5	84.5	24.5	130	160	11	① KS070.9.011 ② -

**PP6A<sup>BR</sup>...** Reaction arm  
Braccio di reazione

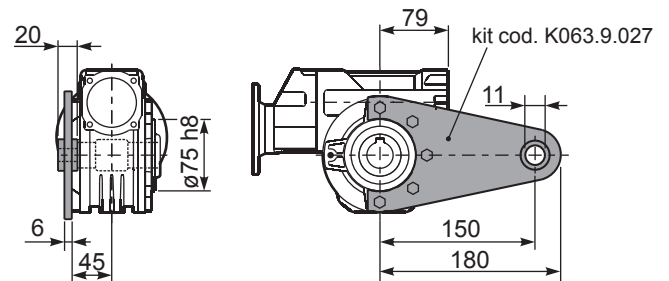

**PP6A.....<sup>S</sup>...** Single Shaft  
Albero lento semplice

**PP6A.....<sup>D</sup>...** Double Shaft  
Albero lento bisp.

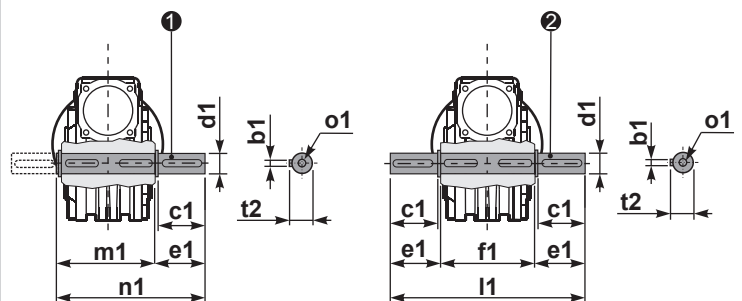

① kit cod. K070.5.028 type B

② kit cod. K070.5.029 type B

**R<sup>P6</sup>AFB...** Input shaft  
Albero in entrata

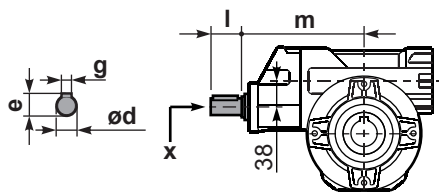

	ød	e	g	l	m	x	
29.9+111	19 h6	21.5	6	35	169.4	M6x16	C40.5.062
139+434	14 h6	16	5	25	154.2	M5x13	C35.5.061

	b1	c1	d1	e1	f1	l1	m1	n1	t2	o1
type B	8	60	28 <sup>-0.005</sup> / <sub>-0.020</sub>	63.5	120	247	127.5	191	31	M8x20
type S	-	-	-	-	-	-	-	-	-	-

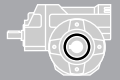

#### QUICK SELECTION / Selezione veloce

input speed ( $n_1$ ) = 1400 min<sup>-1</sup>

Output Speed $n_2$ [min <sup>-1</sup> ]	Ratio $i$	Motor power $P_{1M}$ [kW]	Output torque $M_{2M}$ [Nm]	Service factor f.s.	Nominal power $P_{1R}$ [kW]	Nominal torque $M_{2R}$ [Nm]	Available B5 motor flanges				Available B14 motor flanges			Dynamic efficiency <b>RD</b>	Tooth Module [mm]	Ratios code
							-B	-C	-D	-E	-Q	-R	-T			
							63	71	80	90	71	80	90			
23.5	<b>59.7</b>	1.1	300	1.4	<b>1.5</b>	<b>418</b>					C	C		67	3.5	01
19.4	<b>72.3</b>	1.1	347	1.2	<b>1.3</b>	<b>407</b>					C	C		64	3.1	02
17.1	<b>81.7</b>	1.1	374	1.1	<b>1.2</b>	<b>418</b>					C	C		61	2.7	03
13.3	<b>105</b>	0.75	323	1.2	<b>0.89</b>	<b>385</b>					C	C		60	2.1	04
8.0	<b>176</b>	0.55	415	1.1	<b>0.58</b>	<b>440</b>	B				C	C		63	3.5	05
6.6	<b>213</b>	0.37	322	1.3	<b>0.47</b>	<b>407</b>	B				C	C		60	3.1	06
5.8	<b>240</b>	0.37	321	1.3	<b>0.48</b>	<b>418</b>	B				C	C		53	2.7	07
4.3	<b>328</b>	0.37	438	1.0	<b>0.35</b>	<b>418</b>	B				C	C		53	2.7	08
3.3	<b>422</b>	0.25	374	1.0	<b>0.26</b>	<b>385</b>	B				C	C		52	2.1	09
3.0	<b>466</b>	0.25	358	0.9	<b>0.23</b>	<b>330</b>	B				C	C		45	1.9	10
2.3	<b>605</b>	0.18	297	1.1	<b>0.20</b>	<b>330</b>	B				C	C		40	1.5	11

**Motor Flanges Available**  
Flange Motore Disponibili

**B) Supplied with Reduction Bushing**  
Fornito con Bussola di Riduzione

**B) Available on Request without reduction bushing**  
Disponibile a Richiesta senza Bussola di Riduzione

**C) Motor Flange Holes Position**  
Posizione Fori Flangia Motore

**EN** Unit **P85** is supplied with synthetic oil, providing "long life" lubrication. For mounting position V5-V6 please contact us. See table 1 for lubrication and recommended quantity. In table 2 please see possible radial loads and axial loads on the gearbox.

**I** Il riduttore tipo **P85** viene fornito lubrificato a vita con olio sintetico. Per posizioni V5-V6 contattare il ns. servizio tecnico. Vedi tab.1 per oli e quantità consigliati. In tab.2 sono presenti i carichi radiali e assiali applicabili al riduttore.

**D** Für die Lebensdauerschmierung ist das Getriebe der Größe **P85** mit synthetischem Öl befüllt. Bei Einbaulage V5 oder V6 bitten wir um Rücksprache. In Tabelle 1 ist die Schmiermenge und das empfohlene Schmiermittel angegeben. In Tabelle 2 sind die zulässigen Radial- und Axialbelastungen des Getriebes aufgeführt.

**F** Le réducteur de type **P85** est fourni lubrifié à vie avec de l'huile synthétique. Concernant les positions V5.V6, contactez notre service d'assistance technique. Voir tableau 1 concernant les huiles et les quantités conseillées. Les charges radiales et axiales applicables au réducteur sont précisées dans le tableau 2.

**E** El reductor tamaño **P85** se suministra, lubricado de por vida con aceite sintético. Para las posiciones V5 y V6 contactar con nuestro servicio técnico. Ver tabla 1, para cantidades y aceites recomendados. En la tabla 2, se encuentran las cargas radiales y axiales admitidas por el reductor.

#### LUBRICATION P85 Oil

For B3-V5-V6 separate lubrication for A ( 1.20 l ) B ( 0.14 l ) , for B6-B7-B8 common lubrication 0.90 l ( A + B ).



**AGIP** Telium VSF 320

**SHELL** Omala S4 WE 320

For all details on lubrication and plugs check our website **tab. 1**  
Per maggiori dettagli su lubrificazione e tappi olio vedi il nostro sito web

#### RADIAL AND AXIAL LOADS

##### Output shaft

Albero di uscita

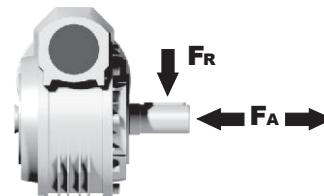

$n_2$ [min <sup>-1</sup> ]	FA [N]	FR [N]
<b>75</b>	700	3500
<b>50</b>	800	4000
<b>25</b>	1000	5000
<b>15-6</b>	1160	5800

##### Input shaft

albero in entrata

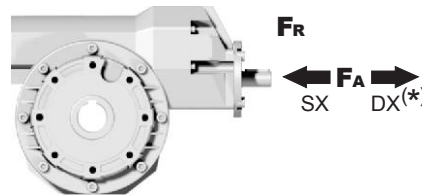

$n_1$ [min <sup>-1</sup> ]	FA [N]	FR [N]
<b>1400</b>	108	540

**\*Strong axial loads in the DX direction are not allowed.**  
Non sono consentiti forti carichi assiali con direzione DX

**tab. 2**

PP85**FB**... Basic wormbox  
Riduttore base

Gearbox weight  
peso riduttore **19.30 kg**

M. flanges	Kit code	øF	A
63B5	K063.4.041	140	195.2
71B5	K063.4.042	160	193.2
80/90B5	K063.4.043	200	195.2
71B14	K063.4.047	105	193.2
80B14	K063.4.046	120	195.2
90B14	K063.4.041	140	195.2

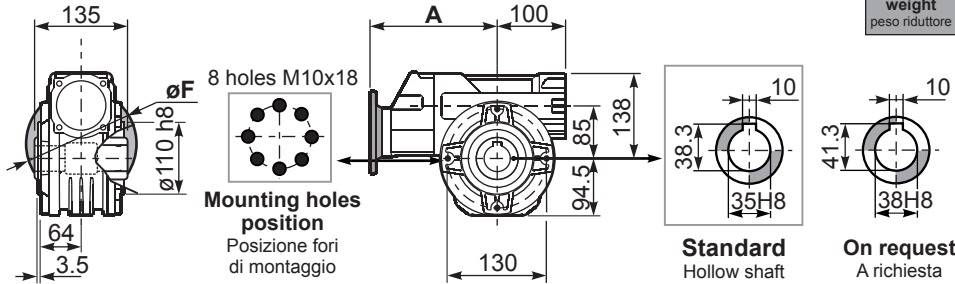

PP85**PA**... Feet  
Piedini

PP85**PB**... Feet  
Piedini

PP85**PV**... Feet  
Piedini

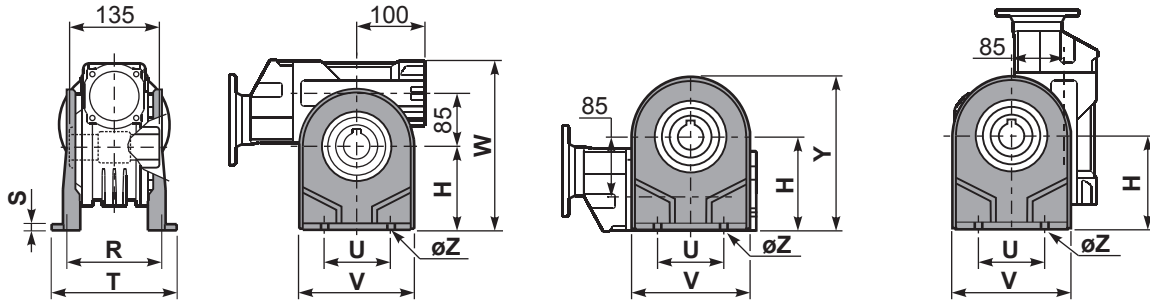

	H	R	S	T	U	V	Y	W	øZ	kit code
type B	142	145	5	182	140	180	236.5	280	ø10.5	K085.9.022
type S	-	-	-	-	-	-	-	-	-	-

PP85**FC**... Output flange  
Flangia uscita

PP85**BR**... Reaction arm  
Braccio di reazione

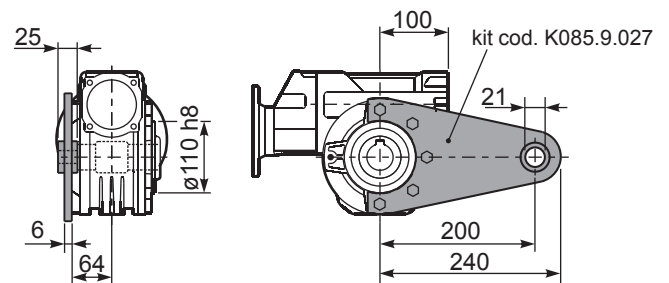
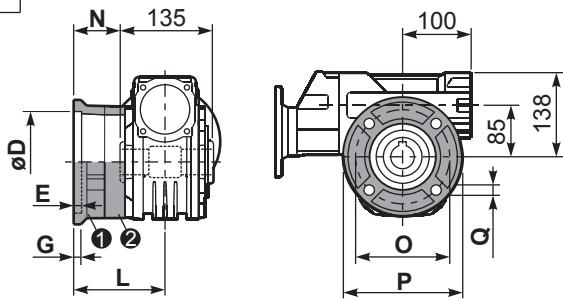

type B	øD	E	G	L	N	O	P	Q	kit code
FC	152 <sup>+0.06</sup> / <sub>+0.00</sub>	5	16	108	40.5	176	205	13	1 ① K085.9.010 2 ② -
FL	152 <sup>+0.06</sup> / <sub>+0.00</sub>	5	16	148.5	81	176	205	13	1 ① K085.9.010 2 ② K085.0.201

PP85.....**S**... Single Shaft  
Albero lento semplice

PP85.....**D**... Double Shaft  
Albero lento bisp.

type S	øD	E	G	L	N	O	P	Q	kit code
F1	130 <sup>+0.04</sup> / <sub>+0.00</sub>	5	13	117.5	50	165	200	11.5	1 ① KS085.9.012 2 ② -
F2	152 <sup>+0.06</sup> / <sub>+0.00</sub>	5	15	147.5	80	180	205	12.5	1 ① KS085.9.013 2 ② -
F4	130 <sup>+0.04</sup> / <sub>+0.00</sub>	5	13	106.5	39	165	200	13	1 ① KS085.9.015 2 ② -

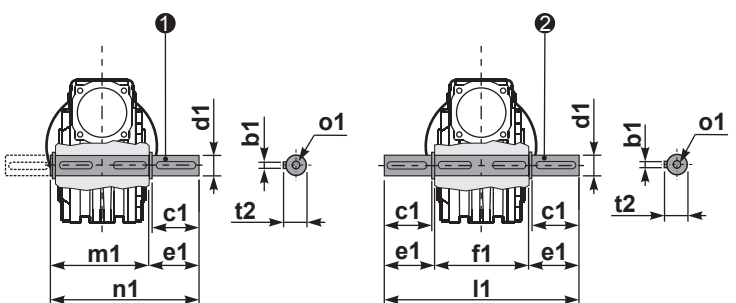

① kit cod. K085.5.028 type B

② kit cod. K085.5.029 type B

RP85**FB**... Input shaft  
Albero in entrata

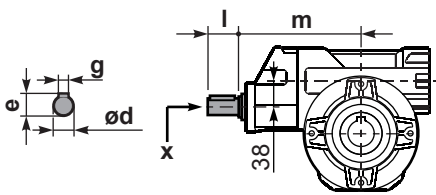

	ød	e	g	l	m	x	
type B	19 h6	21.5	6	35	187.5	M6x16	C40.5.062
type S	-	-	-	-	-	-	-

	b1	c1	d1	e1	f1	l1	m1	n1	t2	o1
type B	10	60	35 <sup>-0.005</sup> / <sub>-0.020</sub>	73.5	135	282	141	214.5	38	M10x23
type S	-	-	-	-	-	-	-	-	-	-

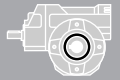

#### QUICK SELECTION / Selezione veloce

input speed ( $n_1$ ) = 1400 min<sup>-1</sup>

Output Speed $n_2$ [min <sup>-1</sup> ]	Ratio $i$	Motor power $P_{1M}$ [kW]	Output torque $M_{2M}$ [Nm]	Service factor f.s.	Nominal power $P_{1R}$ [kW]	Nominal torque $M_{2R}$ [Nm]	Available B5 motor flanges				Available B14 motor flanges			Dynamic efficiency <b>RD</b>	Tooth Module [mm]	Ratios code 
							-B	-C	-D	-E	-Q	-R	-T			
							63	71	80	90	71	80	90			
16.8	<b>83.2</b>	1.5	587	1.1	<b>1.7</b>	<b>660</b>					<b>C</b>			69	3.5	01
13.9	<b>100.5</b>	1.5	699	0.8	<b>1.3</b>	<b>594</b>					<b>C</b>			68	2.9	02
10.6	<b>132</b>	1.1	634	0.9	<b>0.95</b>	<b>550</b>					<b>C</b>			64	2.2	03
8.0	<b>176</b>	0.75	666	1.2	<b>0.90</b>	<b>803</b>	<b>B</b>				<b>C</b>			74	4.7	04
6.7	<b>208</b>	0.75	766	0.9	<b>0.65</b>	<b>660</b>	<b>B</b>				<b>C</b>			72	4.0	05
5.7	<b>245</b>	0.55	634	1.0	<b>0.57</b>	<b>660</b>	<b>B</b>				<b>C</b>			69	3.5	06
4.7	<b>296</b>	0.55	755	0.8	<b>0.43</b>	<b>594</b>	<b>B</b>				<b>C</b>			68	2.9	07
4.2	<b>334</b>	0.55	865	0.8	<b>0.42</b>	<b>660</b>	<b>B</b>				<b>C</b>			69	3.5	08
3.5	<b>403</b>	0.37	692	0.9	<b>0.32</b>	<b>594</b>	<b>B</b>				<b>C</b>			68	2.9	09
2.6	<b>529</b>	0.25	577	1.0	<b>0.24</b>	<b>550</b>	<b>B</b>				<b>C</b>			64	2.2	10
2.2	<b>624</b>	0.25	628	0.8	<b>0.21</b>	<b>528</b>	<b>B</b>				<b>C</b>			59	1.9	11

**Motor Flanges Available**  
Flange Motore Disponibili

**B) Supplied with Reduction Bushing**  
Fornito con Bussola di Riduzione

**B) Available on Request without reduction bushing**  
Disponibile a Richiesta senza Bussola di Riduzione

**C) Motor Flange Holes Position**  
Posizione Fori Flangia Motore

**EN** Unit P10 is supplied without lubricant and equipped with a breather, level and drain plugs. User can add mineral oil keeping existing plugs. Should the user wish to fill it with synthetic oil, it is recommended to replace the existing plugs with a closed plug. Primary reduction unit is supplied with closed plugs and lubricated for life with synthetic oil. See table 1 for lubrication and recommended quantity. In table 2 please see possible radial loads and axial loads on the gearbox.

**I** Il riduttore tipo P10 è fornito privo di lubrificazione con tappi di sfiato, livello e scarico olio. L'utente può immettere olio minerale mantenendo i tappi esistenti. Se immetterà olio sintetico, dovrà sostituire i tappi esistenti con altri tipo chiuso. La precoppia è fornita con tappi chiusi e lubrificata a vita con olio sintetico. Tab.1 per oli e quantità consigliati. Tab.2 carichi radiali e assiali applicabili al riduttore.

**D** Das Getriebe der Baugröße P10 wird ohne Schmiermittel geliefert. Es ist jedoch mit Einfüllschraube, Überdruckventil und Ablassschraube ausgerüstet. Das benötigte mineralische Öl kann über die Einfüllschraube eingefüllt werden. Sollte synthetisches Öl bevorzugt werden, so ist sind das eingebaute Überdruckventil durch eine geschlossenen Schraube zu ersetzen. Die Stirnradvorstufe ist Lebensdauer geschmiert und wird mit synthetischem Öl geliefert. Die Stirnradvorstufe ist komplett geschlossen ohne Füllschrauben. In Tabelle 1 ist die Schmiermenge und das empfohlene Schmiermittel angegeben. In Tabelle 2 sind die zulässigen Radial- und Axialbelastungen des Getriebes aufgeführt.

**F** Le réducteur de type P10 est fourni sans lubrification et avec un bouchon de remplissage, de niveau et d'évacuation de l'huile. L'utilisateur peut y verser de l'huile minérale en conservant les bouchons existants. S'il y versera de l'huile synthétique, il devra substituer les bouchons existants avec d'autres bouchons de type fermé. Le pré couple est fourni lubrifié à vie avec de l'huile synthétique et avec des bouchons fermés. Voir tableau 1 concernant les huiles et les quantités conseillées. Voir tableau 2 concernant les charges radiales et axiales applicables au réducteur

**E** El reductor tamaño P10 se suministra sin lubricante, provisto de tapones de respiración, nivel y descarga de aceite. El usuario puede utilizar aceite mineral, manteniendo los tapones existentes. Si prefiere utilizar aceite sintético deberá sustituir los tapones existentes por tapones ciegos. La prerreducción se suministra con tapones ciegos, lubricado de por vida con aceite sintético. Ver tabla 1, para cantidades y aceites recomendados. En la tabla 2, se encuentran las cargas radiales y axiales admitidas por el reductor.

B3	B6	B7	B8	V5	V6
2.0/0.14LT	1.35/0.14 LT	1.35/0.14 LT	2.0/0.14 LT	2.0/0.14 LT	2.0/0.14 LT

AGIP Blasias 460

For all details on lubrication and plugs check our website [tab. 1](#)  
Per maggiori dettagli su lubrificazione e tappi olio vedi il nostro sito web

#### RADIAL AND AXIAL LOADS

**Output shaft**  
Albero di uscita

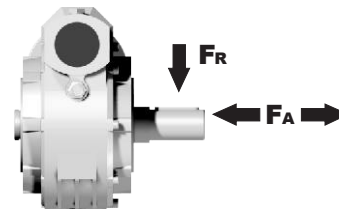

$n_2$ [min <sup>-1</sup> ]	FA [N]	FR [N]
75	800	4000
50	920	4600
25	1200	6000
15-6	1400	7000

**Input shaft**  
albero in entrata

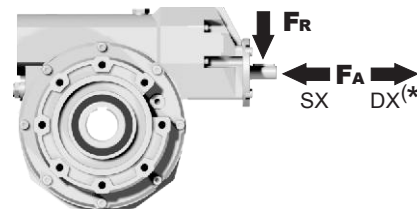

$n_1$ [min <sup>-1</sup> ]	FA [N]	FR [N]
1400	150	760

**\*Strong axial loads in the DX direction are not allowed.**  
Non sono consentiti forti carichi assiali con direzione DX

tab. 2



PP10**FB**... Basic wormbox  
Riduttore base

Gearbox weight  
peso riduttore **41.00 kg**

M. flanges	Kit code	øF	A
63B5	K063.4.041	140	214.7
71B5	K063.4.042	160	212.7
80/90B5	K063.4.043	200	214.7
71B14	K063.4.047	105	212.7
80B14	K063.4.046	120	214.7
90B14	K063.4.041	140	214.7

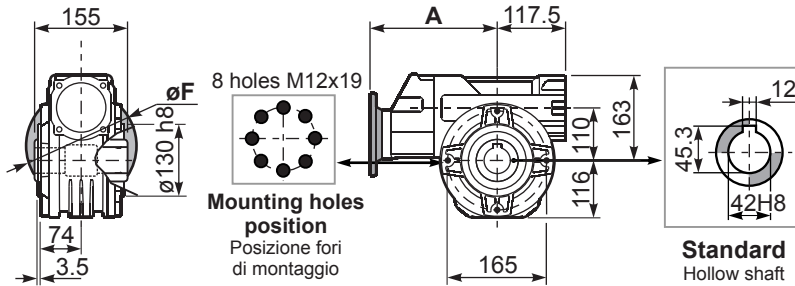

PP10**PA**... Feet  
Piedini

PP10**PB**... Feet  
Piedini

PP10**PV**... Feet  
Piedini

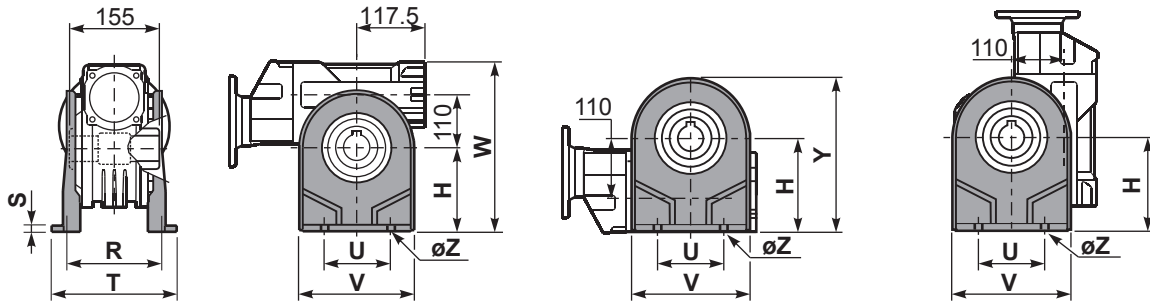

	H	R	S	T	U	V	Y	W	øZ	kit code
type B	170	180	22	224	200	240	286	333	ø13	K110.9.022
type S	172	160	8	204	200	240	288	335	ø14	KS110.9.023

PP10**FC**... Output flange  
Flangia uscita

PP10**BR**... Reaction arm  
Braccio di reazione

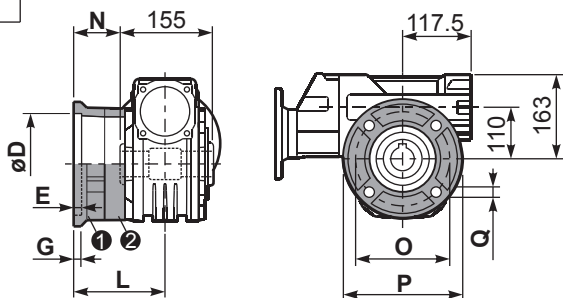

type B	øD	E	G	L	N	O	P	Q	kit code
FC	170 <sup>+0.083</sup> <sub>0</sub>	11	16.5	131.5	54	230	270	13	① K110.9.010 ② -
FL	170 <sup>+0.083</sup> <sub>0</sub>	11	16.5	179.5	102	230	270	13	① K110.9.011 ② -

type S	øD	E	G	L	N	O	P	Q	kit code
F1	180 <sup>+0.040</sup> <sub>0</sub>	5	18	150	72.5	215	250	15	① KS110.9.014 ② -
F2	170 <sup>+0.083</sup> <sub>0</sub>	9.5	15	178	100.5	230	270	13	① KS110.9.012 ② -
F3	180 <sup>+0.040</sup> <sub>0</sub>	5	18	130	52.5	215	250	15	① KS110.9.013 ② -

PP10.....**S**... Single Shaft  
Albero lento semplice

PP10.....**D**... Double Shaft  
Albero lento bisp.

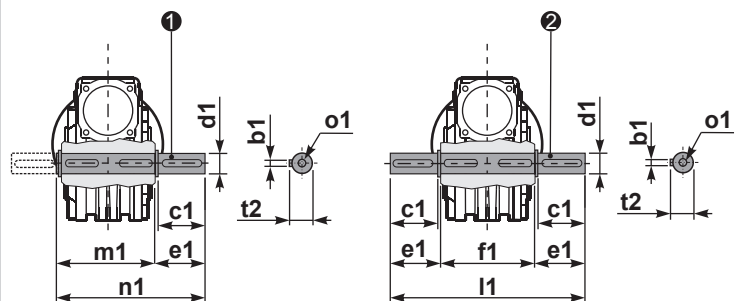

① kit cod. K110.5.028 type B

② kit cod. K110.5.029 type B

RP10**FB**... Input shaft  
Albero in entrata

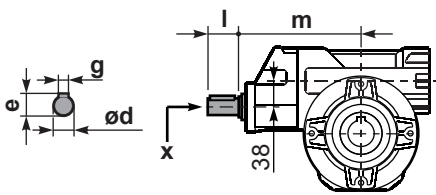

	ød	e	g	l	m	x
type B	19 h6	21.5	6	35	205	M6x16
type S	-	-	-	-	-	-

	b1	c1	d1	e1	f1	l1	m1	n1	t2	o1
type B	12	75	42 <sup>-0.005</sup> <sub>-0.020</sub>	96.5	155	348	163.5	260	45	M12x32
type S	-	-	-	-	-	-	-	-	-	-

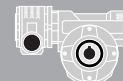

#### QUICK SELECTION / Selezione veloce

input speed ( $n_1$ ) = 1400 min<sup>-1</sup>

Output Speed $n_2$ [min <sup>-1</sup> ]	Ratio $i$	Motor power $P_{1M}$ [kW]	Output torque $M_{2M}$ [Nm]	Service factor f.s.	Nominal power $P_{1R}$ [kW]	Nominal torque $M_{2R}$ [Nm]	Available B5 motor flanges		Available B14 motor flanges		Dynamic efficiency <b>RD</b>	Tooth Module  [mm]	Ratios code 
							-A	-B	-O	-P			
							56	63	56	63			
9.3	<b>150</b>	0.06	29	1.2	<b>0.07</b>	<b>35</b>	B		B-C		48	1.44	01
6.7	<b>210</b>	0.06	39	0.9	<b>0.05</b>	<b>35</b>	B		B-C		45	1.44	02
4.7	<b>300</b>	0.06*	35	<0.8	<b>0.05</b>	<b>35</b>	B		B-C		36	1.44	03
3.1	<b>450</b>	0.06*	35	<0.8	<b>0.03</b>	<b>35</b>	B		B-C		33	1.44	04
2.3	<b>600</b>	0.06*	35	<0.8	<b>0.03</b>	<b>35</b>	B		B-C		30	1.44	05
1.6	<b>900</b>	0.06*	35	<0.8	<b>0.02</b>	<b>35</b>	B		B-C		27	1.44	06
1.2	<b>1200</b>	0.06*	35	<0.8	<b>0.02</b>	<b>35</b>	B		B-C		26	1.44	07
0.8	<b>1830</b>	0.06*	35	<0.8	<b>0.01</b>	<b>35</b>	B		B-C		24	1.44	08
0.6	<b>2400</b>	0.06*	35	<0.8	<b>0.01</b>	<b>35</b>	B		B-C		22	1.44	09

**A) Motor Flanges Available**  
Flange Motore Disponibili

**B) Supplied with Reduction Bushing**  
Fornito con Bussola di Riduzione

**B) Available on Request without reduction bushing**  
Disponibile a Richiesta senza Bussola di Riduzione

**C) Motor Flange Holes Position**  
Posizione Fori Flangia Motore

\* Power higher than the maximum one which can be supported by the gearbox. Select according to the torque  $M_{2R}$   
Potenza superiore a quella massima sopportabile dal riduttore. Selezionare in base al momento torcente  $M_{2R}$

**EN** Unit 303 is supplied with synthetic oil, providing "long life" lubrication. For mounting position V5-V6 please contact us. See table 1 for lubrication and recommended quantity. In table 2 please see possible radial loads and axial loads on the gearbox.

**I** Il riduttore tipo 303 viene fornito lubrificato a vita con olio sintetico. Per posizioni V5-V6 contattare il ns. servizio tecnico. Vedi tab.1 per oli e quantità consigliati. In tab.2 sono presenti i carichi radiali e assiali applicabili al riduttore.

**D** Für die Lebensdauerschmierung ist das Getriebe der Größe 303 mit synthetischem Öl befüllt. Bei Einbaulage V5 oder V6 bitten wir um Rücksprache. In Tabelle 1 ist die Schmiermenge und das empfohlene Schmiermittel angegeben. In Tabelle 2 sind die zulässigen Radial- und Axialbelastungen des Getriebes aufgeführt.

**F** Le réducteur de type 303 est fourni lubrifié à vie avec de l'huile synthétique. Concernant les positions V5.V6, contactez notre service d'assistance technique. Voir tableau 1 concernant les huiles et les quantités conseillées. Les charges radiales et axiales applicables au réducteur sont précisées dans le tableau 2.

**E** El reductor tamaño 303 se suministra, lubricado de por vida con aceite sintético. Para las posiciones V5 y V6 contactar con nuestro servicio técnico. Ver tabla 1, para cantidades y aceites recomendados. En la tabla 2, se encuentran las cargas radiales y axiales admitidas por el reductor.

**LUBRICATION 303 Oil** 0.03 Lt. 0.03 Lt.

**Quantity 0.03/0.03 Lt.**

**AGIP** Telium VSF 320

**SHELL** Omala S4 WE 320

For all details on lubrication and plugs check our website **tab. 1**  
Per maggiori dettagli su lubrificazione e tappi olio vedi il nostro sito web

#### RADIAL AND AXIAL LOADS

##### Output shaft

Albero di uscita

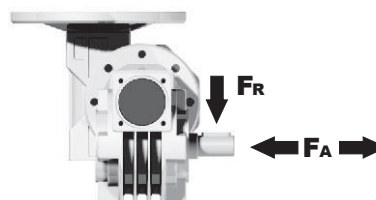

$n_2$ [min <sup>-1</sup> ]	FA [N]	FR [N]
25	300	1800
15	400	2000

##### Input shaft

albero in entrata

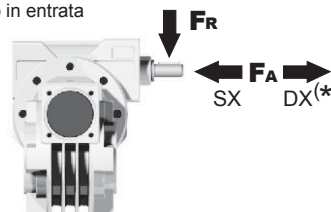

$n_1$ [min <sup>-1</sup> ]	FA [N]	FR [N]
1400	20	100

\*Strong axial loads in the DX direction are not allowed.  
Non sono consentiti forti carichi assiali con direzione DX

tab. 2

3D dimensions on request

**P303FB...** Basic wormbox  
Riduttore base

Gearbox weight  
peso riduttore **2.15 kg**

M. flanges	Kit code	øF	A
<b>56B5</b>	K030.4.041	120	61.5
<b>63B5</b>	K030.4.042	140	62.5
<b>56B14</b>	K030.4.046	80	61.5
<b>63B14</b>	K030.4.045	90	62.5

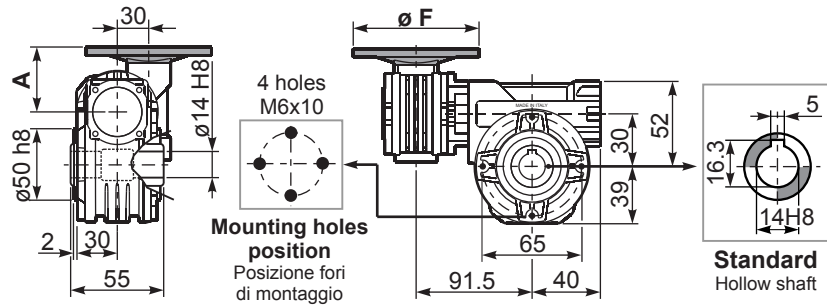

**P303PA...** Feet  
Piedini

**P303PB...** Feet  
Piedini

**P303PV...** Feet  
Piedini

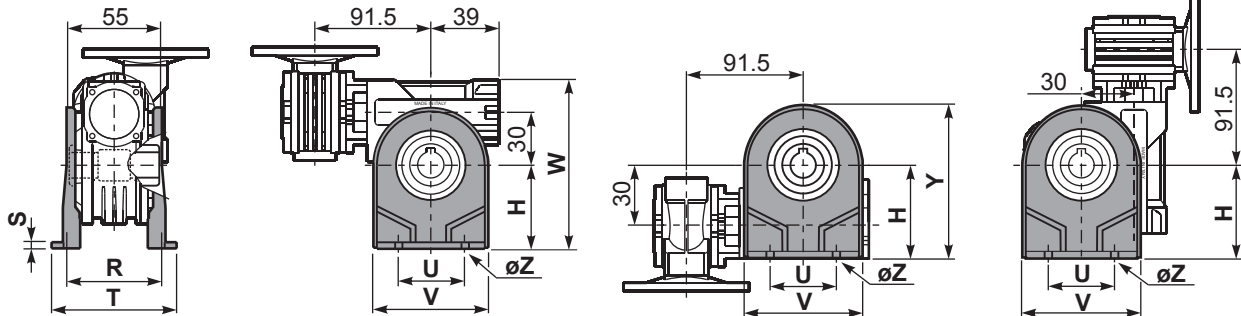

	H	R	S	T	U	V	Y	W	øZ	kit code
type B	55	66	3	87	50	78	94	107	ø6.5	K030.9.022
type S	52	66	3	87	52	90	91	104	ø6.5	KS030.9.023

**P303FC...** Output flange  
Flangia uscita

**P303BR...** Reaction arm  
Braccio di reazione

kit cod. K045.9.027

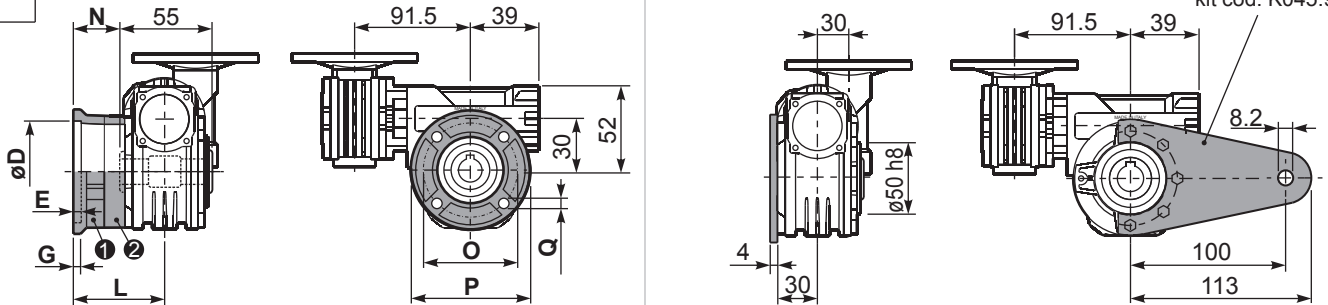

type B	øD	E	G	L	N	O	P	Q	kit code
<b>FC</b>	50 <sup>+0.15</sup> / <sub>+0.05</sub>	6	6	50.5	23	68	80	7	① K030.9.010 ② -
<b>FL</b>	60 <sup>+0.15</sup> / <sub>+0.05</sub>	6	6	55.5	28	87	110	8.5	① K030.9.011 ② -
type S	øD	E	G	L	N	O	P	Q	kit code
<b>F1</b>	40 <sup>+0.15</sup> / <sub>+0.10</sub>	3.5	5.5	49	21.5	56	80	6.5	① KS030.9.012 ② -

**P303....S...** Single Shaft  
Albero lento semplice

**P303....D...** Double Shaft  
Albero lento bisp.

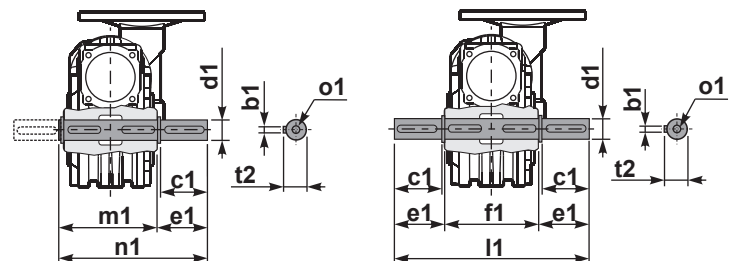

① kit cod. K030.5.028 type B

② kit cod. K030.5.029 type B

**R303FB...** Input shaft  
Albero in entrata

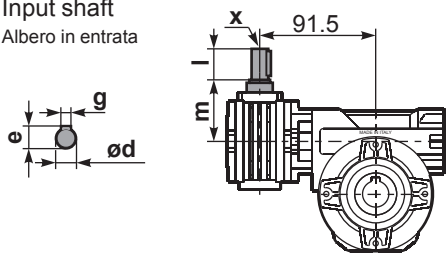

	ød	e	g	l	m	x	kit code
type B	9 h6	10.2	3	20	58	-	K030.5.006 PAM63
type S	-	-	-	-	-	-	-

	b1	c1	d1	e1	f1	l1	m1	n1	t2	o1
type B	5	25	14 <sup>-0.005</sup> / <sub>-0.020</sub>	35.5	55	126	59	94.5	15.8	M5x14
type S	-	-	-	-	-	-	-	-	-	-

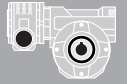

#### QUICK SELECTION / Selezione veloce

input speed ( $n_1$ ) = 1400 min<sup>-1</sup>

Output Speed $n_2$ [min <sup>-1</sup> ]	Ratio $i$	Motor power $P_{1M}$ [kW]	Output torque $M_{2M}$ [Nm]	Service factor f.s.	Nominal power $P_{1R}$ [kW]	Nominal torque $M_{2R}$ [Nm]	Available B5 motor flanges		Available B14 motor flanges		Dynamic efficiency <b>RD</b>	Tooth Module [mm]	Ratios code 
							-A	-B	-O	-P			
							56	63	56	63			
10.0	<b>140</b>	0.12	57	1.2	<b>0.14</b>	<b>69</b>	B		B-C		50	2.2	01
7.0	<b>200</b>	0.12	79	0.9	<b>0.11</b>	<b>69</b>	B		B-C		48	2.2	02
5.0	<b>280</b>	0.12*	69	<0.8	<b>0.08</b>	<b>69</b>	B		B-C		45	2.4	03
3.3	<b>420</b>	0.12*	69	<0.8	<b>0.07</b>	<b>69</b>	B		B-C		36	1.6	04
2.5	<b>560</b>	0.12*	69	<0.8	<b>0.05</b>	<b>69</b>	B		B-C		33	2.5	05
1.9	<b>740</b>	0.12*	69	<0.8	<b>0.05</b>	<b>69</b>	B		B-C		30	1.8	06
1.5	<b>920</b>	0.12*	69	<0.8	<b>0.04</b>	<b>69</b>	B		B-C		27	1.5	07
1.3	<b>1120</b>	0.12*	69	<0.8	<b>0.03</b>	<b>69</b>	B		B-C		26	2.5	08
0.9	<b>1480</b>	0.12*	69	<0.8	<b>0.03</b>	<b>69</b>	B		B-C		24	1.8	09
0.8	<b>1840</b>	0.12*	69	<0.8	<b>0.02</b>	<b>69</b>	B		B-C		22	1.5	10
0.6	<b>2400</b>	0.12*	69	<0.8	<b>0.02</b>	<b>69</b>	B		B-C		21	1.2	11

**Motor Flanges Available**  
Flange Motore Disponibili

**B) Supplied with Reduction Bushing**  
Fornito con Bussola di Riduzione

**B) Available on Request without reduction bushing**  
Disponibile a Richiesta senza Bussola di Riduzione

**C) Motor Flange Holes Position**  
Posizione Fori Flangia Motore

\* Power higher than the maximum one which can be supported by the gearbox. Select according to the torque  $M_{2R}$   
Potenza superiore a quella massima sopportabile dal riduttore. Selezionare in base al momento torcente  $M_{2R}$

**EN** Unit 453 is supplied with synthetic oil, providing "long life" lubrication. For mounting position V5-V6 please contact us. See table 1 for lubrication and recommended quantity. In table 2 please see possible radial loads and axial loads on the gearbox.

**I** Il riduttore tipo 453 viene fornito lubrificato a vita con olio sintetico. Per posizioni V5-V6 contattare il ns. servizio tecnico. Vedi tab.1 per oli e quantità consigliati. In tab.2 sono presenti i carichi radiali e assiali applicabili al riduttore.

**D** Für die Lebensdauerschmierung ist das Getriebe der Größe 453 mit synthetischem Öl befüllt. Bei Einbaulage V5 oder V6 bitten wir um Rücksprache. In Tabelle 1 ist die Schmiermenge und das empfohlene Schmiermittel angegeben. In Tabelle 2 sind die zulässigen Radial- und Axialbelastungen des Getriebes aufgeführt.

**F** Le réducteur de type 453 est fourni lubrifié à vie avec de l'huile synthétique. Concernant les positions V5.V6, contactez notre service d'assistance technique. Voir tableau 1 concernant les huiles et les quantités conseillées. Les charges radiales et axiales applicables au réducteur sont précisées dans le tableau 2.

**E** El reductor tamaño 453 se suministra, lubricado de por vida con aceite sintético. Para las posiciones V5 y V6 contactar con nuestro servicio técnico. Ver tabla 1, para cantidades y aceites recomendados. En la tabla 2, se encuentran las cargas radiales y axiales admitidas por el reductor.

**LUBRICATION 453 Oil** 0.09 Lt. 0.03 Lt.

**Quantity 0.09/0.03 Lt.**

**AGIP** Telium VSF 320

**SHELL** Omala S4 WE 320

For all details on lubrication and plugs check our website **tab. 1**  
Per maggiori dettagli su lubrificazione e tappi olio vedi il nostro sito web

#### RADIAL AND AXIAL LOADS

**Output shaft**  
Albero di uscita

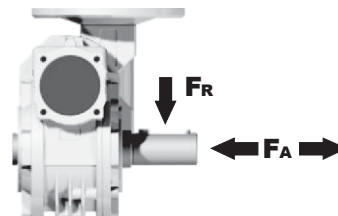

$n_2$ [min <sup>-1</sup> ]	FA [N]	FR [N]
25	300	1800
15	400	2000

**Input shaft**  
albero in entrata

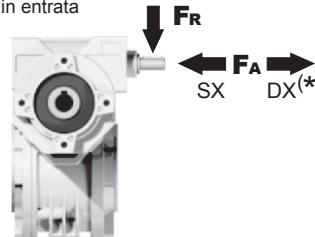

$n_1$ [min <sup>-1</sup> ]	FA [N]	FR [N]
1400	20	100

\*Strong axial loads in the DX direction are not allowed.  
Non sono consentiti forti carichi assiali con direzione DX

**tab. 2**

3D dimensions on request

**P453FB...** Basic wormbox  
Riduttore base

Gearbox weight  
peso riduttore **3.60 kg**

M. flanges	Kit code	øF	A
<b>56B5</b>	K030.4.041	120	61.5
<b>63B5</b>	K030.4.042	140	62.5
<b>56B14</b>	K030.4.046	80	61.5
<b>63B14</b>	K030.4.045	90	62.5

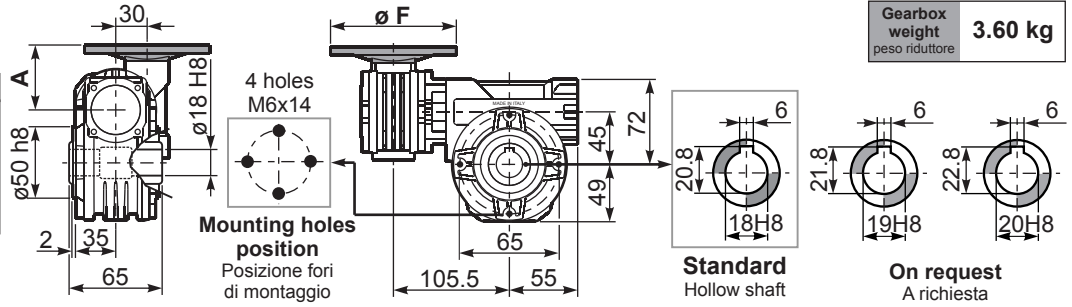

**P453PA...** Feet  
Piedini

**P453PB...** Feet  
Piedini

**P453PV...** Feet  
Piedini

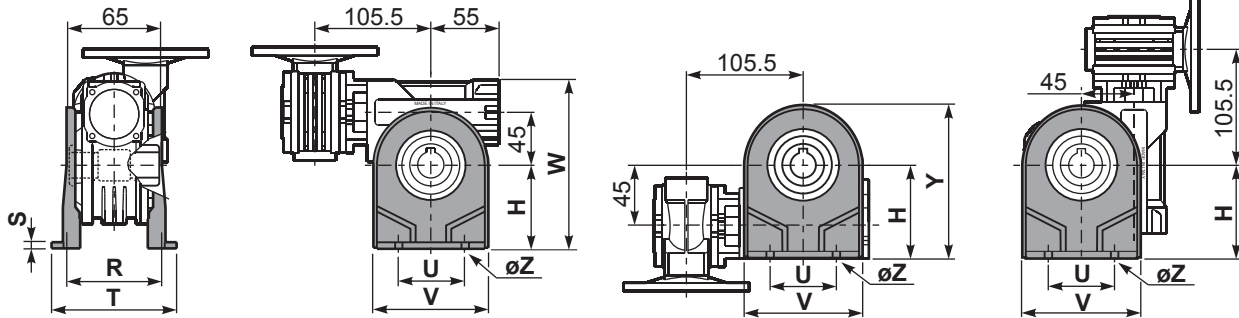

	H	R	S	T	U	V	Y	W	øZ	kit code
type B	72	81	3	100	52	98	121	144	ø10.5	K045.9.022
type S	71	84	8	100	70	90	120	143	ø8	KS045.9.023

**P453FC...** Output flange  
Flangia uscita

**P453BR...** Reaction arm  
Braccio di reazione

kit cod. K045.9.027

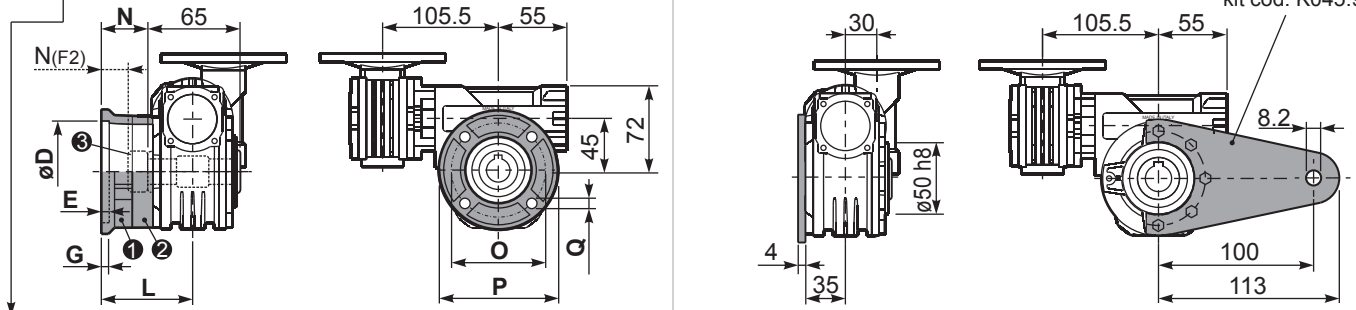

type B	øD	E	G	L	N	O	P	Q	kit code
<b>FC</b>	60 <sup>+0.15</sup> / <sub>-0.05</sub>	9	9	60.5	28	87	110	8.5	① K045.9.010 ② -
<b>FL</b>	60 <sup>+0.15</sup> / <sub>-0.05</sub>	9	9	90.5	58	87	110	8.5	① K045.9.010 ② K045.0.200

type S	øD	E	G	L	N	O	P	Q	kit code
<b>F1</b>	95 <sup>+0.20</sup> / <sub>-0.15</sub>	4	11	73.5	41	115	140	9	① KS045.9.013 ② -
<b>F2</b>	60 <sup>+0.15</sup> / <sub>-0.05</sub>	9	9	60.5	19	87	110	8.5	① KS045.9.010 ② S045.0.204
<b>F3</b>	80 <sup>+0.030</sup> / <sub>0</sub>	3	8	51.5	19	100	120	9	① KS045.9.014 ② -

**P453....S...** Single Shaft  
Albero lento semplice

**P453....D...** Double Shaft  
Albero lento bisp.

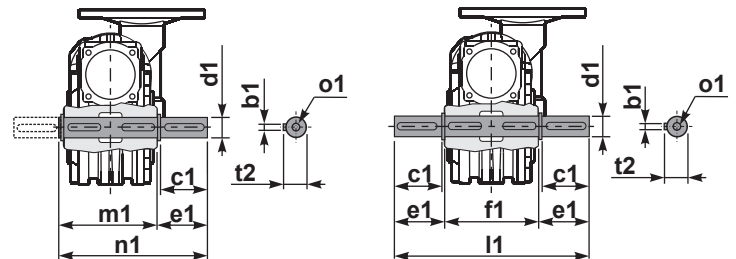

- ① kit cod. K045.5.028 type B  
kit cod. KS045.5.030 type S
- ② kit cod. K045.5.029 type B  
kit cod. KS045.5.031 type S

**R453FB...** Input shaft  
Albero in entrata

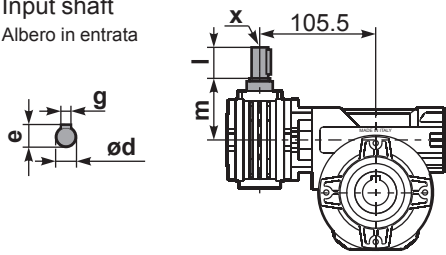

	ød	e	g	l	m	x	kit code
type B	9 h6	10.2	3	20	58	-	① K030.5.006 PAM63 ② -
type S	-	-	-	-	-	-	① - ② -

	b1	c1	d1	e1	f1	l1	m1	n1	t2	o1
type B	6	32	18 <sup>-0.005</sup> / <sub>-0.020</sub>	43	65	151	70	113	20.5	M6x18
type S	6	40	19 <sup>-0.005</sup> / <sub>-0.020</sub>	58.5	65	182	70	128.5	21.5	M8x20

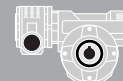

#### QUICK SELECTION / Selezione veloce

input speed ( $n_1$ ) = 1400 min<sup>-1</sup>

Output Speed $n_2$ [min <sup>-1</sup> ]	Ratio $i$	Motor power $P_{1M}$ [kW]	Output torque $M_{2M}$ [Nm]	Service factor f.s.	Nominal power $P_{1R}$ [kW]	Nominal torque $M_{2R}$ [Nm]	Available B5 motor flanges		Available B14 motor flanges		Dynamic efficiency <b>RD</b>	Tooth Module [mm]	Ratios code
							-A	-B	-O	-P			
							56	63	56	63			
5.6	<b>252</b>	0.12	97	1.1	<b>0.14</b>	<b>109</b>	B		B-C		47	2.1	01
3.9	<b>360</b>	0.12	124	0.9	<b>0.11</b>	<b>109</b>	B		B-C		42	2.1	02
2.6	<b>540</b>	0.12*	109	<0.8	<b>0.08</b>	<b>109</b>	B		B-C		39	2.1	03
1.9	<b>720</b>	0.12*	109	<0.8	<b>0.06</b>	<b>109</b>	B		B-C		36	2.1	04
1.6	<b>860</b>	0.12*	109	<0.8	<b>0.06</b>	<b>109</b>	B		B-C		32	1.8	05
1.2	<b>1200</b>	0.12*	109	<0.8	<b>0.05</b>	<b>109</b>	B		B-C		27	1.3	06
1.0	<b>1440</b>	0.12*	109	<0.8	<b>0.04</b>	<b>109</b>	B		B-C		26	2.1	07
0.8	<b>1720</b>	0.12*	109	<0.8	<b>0.04</b>	<b>109</b>	B		B-C		25	1.8	08
0.6	<b>2400</b>	0.12*	104	<0.8	<b>0.03</b>	<b>104</b>	B		B-C		21	1.3	09

**A) Motor Flanges Available**  
Flange Motore Disponibili

**B) Supplied with Reduction Bushing**  
Fornito con Bussola di Riduzione

**B) Available on Request without reduction bushing**  
Disponibile a Richiesta senza Bussola di Riduzione



**C) Motor Flange Holes Position**  
Posizione Fori Flangia Motore

\* Power higher than the maximum one which can be supported by the gearbox. Select according to the torque  $M_{2R}$   
Potenza superiore a quella massima sopportabile dal riduttore. Selezionare in base al momento torcente  $M_{2R}$

**EN** Unit 503 is supplied with synthetic oil, providing "long life" lubrication. For mounting position V5-V6 please contact us. See table 1 for lubrication and recommended quantity. In table 2 please see possible radial loads and axial loads on the gearbox.

**I** Il riduttore tipo 503 viene fornito lubrificato a vita con olio sintetico. Per posizioni V5-V6 contattare il ns. servizio tecnico. Vedi tab.1 per oli e quantità consigliati. In tab.2 sono presenti i carichi radiali e assiali applicabili al riduttore.

**D** Für die Lebensdauerschmierung ist das Getriebe der Größe 503 mit synthetischem Öl befüllt. Bei Einbaulage V5 oder V6 bitten wir um Rücksprache. In Tabelle 1 ist die Schmiermenge und das empfohlene Schmiermittel angegeben. In Tabelle 2 sind die zulässigen Radial- und Axialbelastungen des Getriebes aufgeführt.

**F** Le réducteur de type 503 est fourni lubrifié à vie avec de l'huile synthétique. Concernant les positions V5.V6, contactez notre service d'assistance technique. Voir tableau 1 concernant les huiles et les quantités conseillées. Les charges radiales et axiales applicables au réducteur sont précisées dans le tableau 2.

**E** El reductor tamaño 503 se suministra, lubricado de por vida con aceite sintético. Para las posiciones V5 y V6 contactar con nuestro servicio técnico. Ver tabla 1, para cantidades y aceites recomendados. En la tabla 2, se encuentran las cargas radiales y axiales admitidas por el reductor.

**LUBRICATION 503 Oil** 0.14 Lt.

**Quantity 0.14/0.03 Lt.** 0.03 Lt.

<b>AGIP</b> Telium VSF 320	<b>SHELL</b> Omala S4 WE 320
----------------------------	------------------------------

For all details on lubrication and plugs check our website **tab. 1**  
Per maggiori dettagli su lubrificazione e tappi olio vedi il nostro sito web

### RADIAL AND AXIAL LOADS

**Output shaft**  
Albero di uscita

$n_2$ [min <sup>-1</sup> ]	FA [N]	FR [N]
25	480	2500
15	560	2800

**Input shaft**  
albero in entrata

$n_1$ [min <sup>-1</sup> ]	FA [N]	FR [N]
1400	20	100

\*Strong axial loads in the DX direction are not allowed.  
Non sono consentiti forti carichi assiali con direzione DX

tab. 2

3D dimensions on request

P503**FB**... Basic wormbox  
Riduttore base

M. flanges	Kit code	øF	A
56B5	K030.4.041	120	61.5
63B5	K030.4.042	140	62.5
56B14	K030.4.046	80	61.5
63B14	K030.4.045	90	62.5

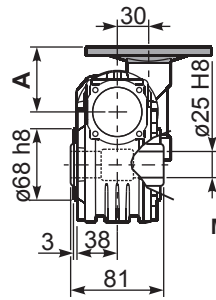

4 holes  
M6x9  
Mounting holes  
position  
Posizione fori  
di montaggio

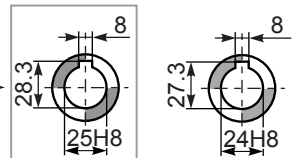
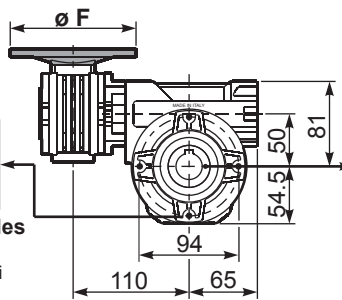

Gearbox  
weight  
peso riduttore **4.20 kg**

Standard Hollow shaft  
On request "type S"  
A richiesta "tipo S"

P503**PA**... Feet  
Piedini

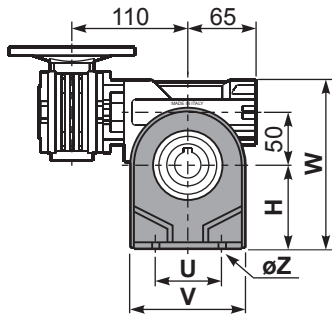
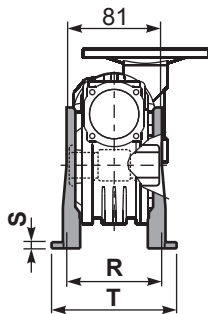

P503**PB**... Feet  
Piedini

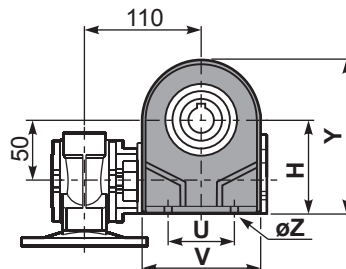

P503**PV**... Feet  
Piedini

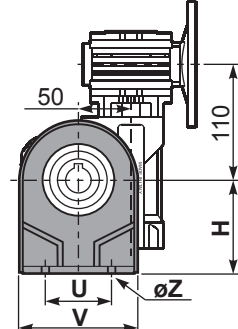

	H	R	S	T	U	V	Y	W	øZ	kit code
type B	82	98.5	3.5	123	63	113	138.5	163	ø10.5	K050.9.022
type S	85	96	10	114	85	110	139.5	166	ø10	KS050.9.023

P503**FC**... Output flange  
Flangia uscita

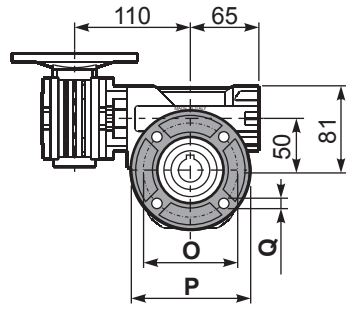
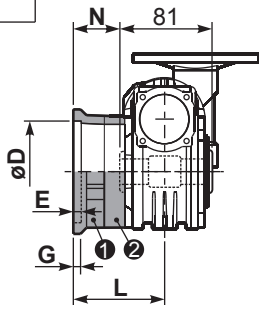

P503**BR**... Reaction arm  
Braccio di reazione

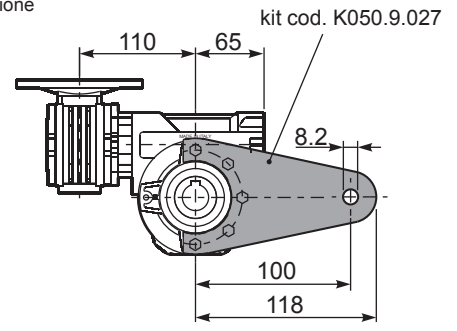
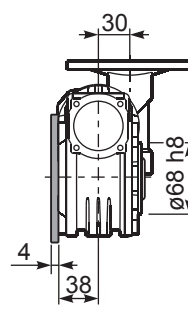

type B	øD	E	G	L	N	O	P	Q	kit code
FC	70 <sup>+0.20</sup> / <sub>+0.15</sub>	9	12	85	44.5	90	123	10.5	1, 2 K050.9.010
FL	70 <sup>+0.20</sup> / <sub>+0.15</sub>	9	12	114.5	74	90	123	10.5	1, 2 K050.9.010 3 K050.0.200
type S	øD	E	G	L	N	O	P	Q	kit code
F1	110 <sup>+0.20</sup> / <sub>+0.15</sub>	4	11	83.5	43	130	160	10	1, 2 KS050.9.012
F2	70 <sup>+0.20</sup> / <sub>+0.15</sub>	9	12	76.5	36	90	123	10.5	1, 2 KS050.9.014
F3	95 <sup>+0.035</sup> / <sub>0</sub>	4	10	66.5	26	115	140	10	1, 2 KS050.9.013

P503....**S**... Single Shaft  
Albero lento semplice

P503....**D**... Double Shaft  
Albero lento bisp.

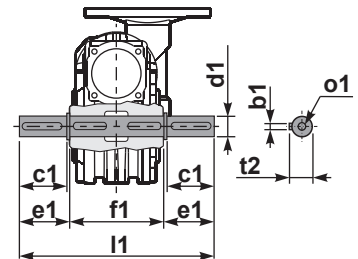
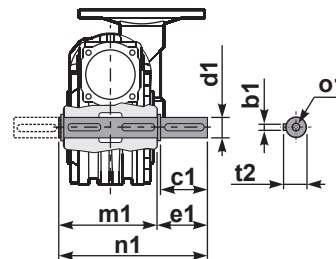

1 kit cod. K050.5.028 type B  
kit cod. KS050.5.030 type S  
2 kit cod. K050.5.029 type B  
kit cod. KS050.5.031 type S

R503**FB**... Input shaft  
Albero in entrata

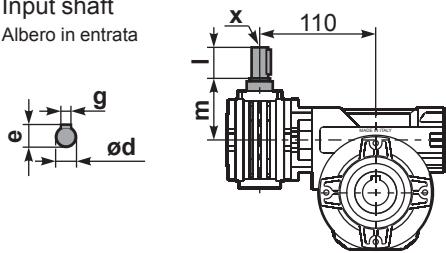

	ød	e	g	l	m	x	kit code
type B	9 h6	10.2	3	20	58	-	1, 2 K030.5.006 PAM63
type S	-	-	-	-	-	-	1, 2 -

	b1	c1	d1	e1	f1	l1	m1	n1	t2	o1
type B	8	52	25 <sup>-0.005</sup> / <sub>-0.020</sub>	59.5	81	200	86.5	146	28	M8x20
type S	8	50	24 <sup>-0.005</sup> / <sub>-0.020</sub>	68.5	81	218	86.5	155	27	M8x20

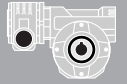

#### QUICK SELECTION / Selezione veloce

input speed ( $n_1$ ) = 1400 min<sup>-1</sup>

Output Speed $n_2$ [min <sup>-1</sup> ]	Ratio $i$	Motor power $P_{1M}$ [kW]	Output torque $M_{2M}$ [Nm]	Service factor f.s.	Nominal power $P_{1R}$ [kW]	Nominal torque $M_{2R}$ [Nm]	Available B5 motor flanges		Available B14 motor flanges		Dynamic efficiency <b>RD</b>	Tooth Module  [mm]	 Ratios code
							-A	-B	-O	-P			
							56	63	56	63			
5.6	<b>252</b>	0.18	142	1.6	<b>0.29</b>	<b>230</b>	B		B-C		46	2.7	01
3.9	<b>360</b>	0.18	181	1.3	<b>0.23</b>	<b>230</b>	B		B-C		41	2.7	02
2.6	<b>540</b>	0.12	164	1.4	<b>0.17</b>	<b>230</b>	B		B-C		37	2.7	03
1.9	<b>720</b>	0.12	200	1.1	<b>0.14</b>	<b>230</b>	B		B-C		34	2.7	04
1.3	<b>1080</b>	0.12	265	0.9	<b>0.10</b>	<b>230</b>	B		B-C		30	2.7	05
1.0	<b>1440</b>	0.12*	230	<0.8	<b>0.09</b>	<b>230</b>	B		B-C		27	2.7	06
0.5	<b>2745</b>	0.12*	230	<0.8	<b>0.05</b>	<b>230</b>	B		B-C		23	2.1	07

**A) Motor Flanges Available**  
Flange Motore Disponibili

**B) Supplied with Reduction Bushing**  
Fornito con Bussola di Riduzione

**B) Available on Request without reduction bushing**  
Disponibile a Richiesta senza Bussola di Riduzione

**C) Motor Flange Holes Position**  
Posizione Fori Flangia Motore

\* Power higher than the maximum one which can be supported by the gearbox. Select according to the torque  $M_{2R}$   
Potenza superiore a quella massima sopportabile dal riduttore. Selezionare in base al momento torcente  $M_{2R}$

**EN** Unit **633** is supplied with synthetic oil, providing "long life" lubrication. For mounting position V5-V6 please contact us. See table 1 for lubrication and recommended quantity. In table 2 please see possible radial loads and axial loads on the gearbox.

**I** Il riduttore tipo **633** viene fornito lubrificato a vita con olio sintetico. Per posizioni V5-V6 contattare il ns. servizio tecnico. Vedi tab.1 per oli e quantità consigliati. In tab.2 sono presenti i carichi radiali e assiali applicabili al riduttore.

**D** Für die Lebensdauerschmierung ist das Getriebe der Größe **633** mit synthetischem Öl befüllt. Bei Einbaulage V5 oder V6 bitten wir um Rücksprache. In Tabelle 1 ist die Schmiermenge und das empfohlene Schmiermittel angegeben. In Tabelle 2 sind die zulässigen Radial - und Axialbelastungen des Getriebes aufgeführt.

**F** Le réducteur de type **633** est fourni lubrifié à vie avec de l'huile synthétique. Concernant les positions V5.V6, contactez notre service d'assistance technique. Voir tableau 1 concernant les huiles et les quantités conseillées. Les charges radiales et axiales applicables au réducteur sont précisées dans le tableau 2.

**E** El reductor tamaño **633** se suministra, lubricado de por vida con aceite sintético. Para las posiciones V5 y V6 contactar con nuestro servicio técnico. Ver tabla 1, para cantidades y aceites recomendados. En la tabla 2, se encuentran las cargas radiales y axiales admitidas por el reductor.

**LUBRICATION 633 Oil** 0.40 Lt. 0.03 Lt.

**Quantity 0.40/0.03 Lt.**

<b>AGIP</b> Telium VSF 320	<b>SHELL</b> Omala S4 WE 320
----------------------------	------------------------------

For all details on lubrication and plugs check our website **tab. 1**  
Per maggiori dettagli su lubrificazione e tappi olio vedi il nostro sito web

#### RADIAL AND AXIAL LOADS

**Output shaft**  
Albero di uscita

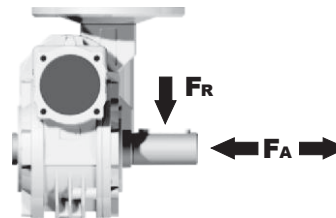

$n_2$ [min <sup>-1</sup> ]	FA [N]	FR [N]
<b>25</b>	700	3800
<b>15</b>	800	4000

**Input shaft**  
albero in entrata

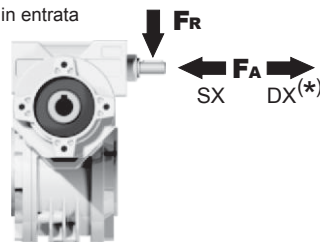

$n_1$ [min <sup>-1</sup> ]	FA [N]	FR [N]
<b>1400</b>	20	100

**\*Strong axial loads in the DX direction are not allowed.**  
Non sono consentiti forti carichi assiali con direzione DX

**tab. 2**



3D dimensions on request

P633**FB**... Basic wormbox  
Riduttore base

Gearbox weight  
peso riduttore **7.50 kg**

M. flanges	Kit code	øF	A
56B5	K030.4.041	120	61.5
63B5	K030.4.042	140	62.5
56B14	K030.4.046	80	61.5
63B14	K030.4.045	90	62.5

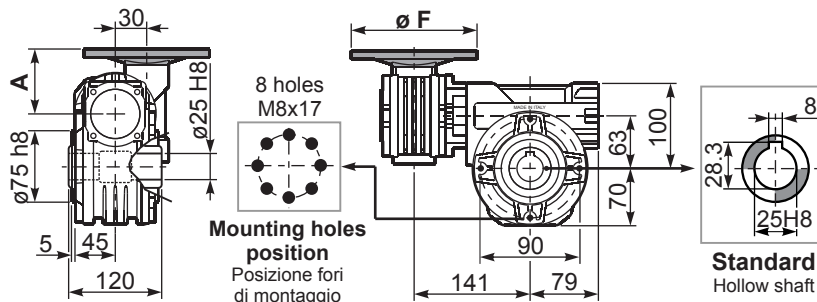

8 holes  
M8x17  
Mounting holes  
position  
Posizione fori  
di montaggio

Standard  
Hollow shaft

P633**PA**... Feet  
Piedini

P633**PB**... Feet  
Piedini

P633**PV**... Feet  
Piedini

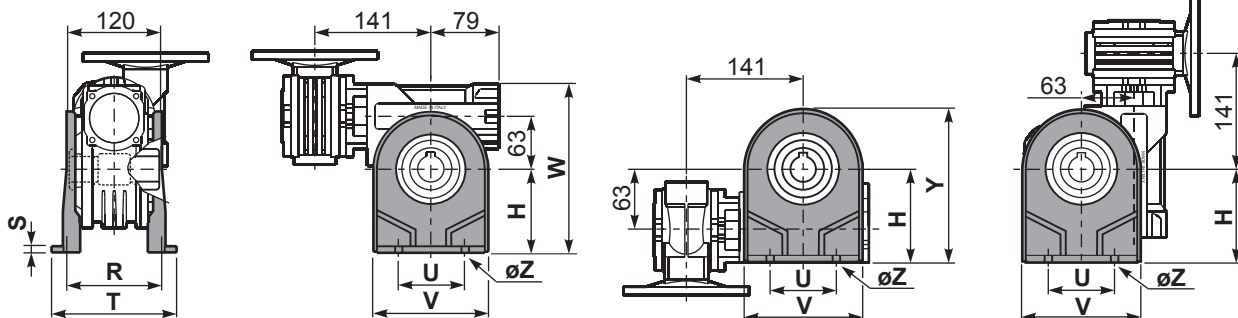

	H	R	S	T	U	V	Y	W	øZ	kit code
type B	100	111	4	144	95	133	170	200	ø10.5	K063.9.022
type S	-	-	-	-	-	-	-	-	-	-

P633**FC**... Output flange  
Flangia uscita

P633**BR**... Reaction arm  
Braccio di reazione

kit cod. K063.9.027

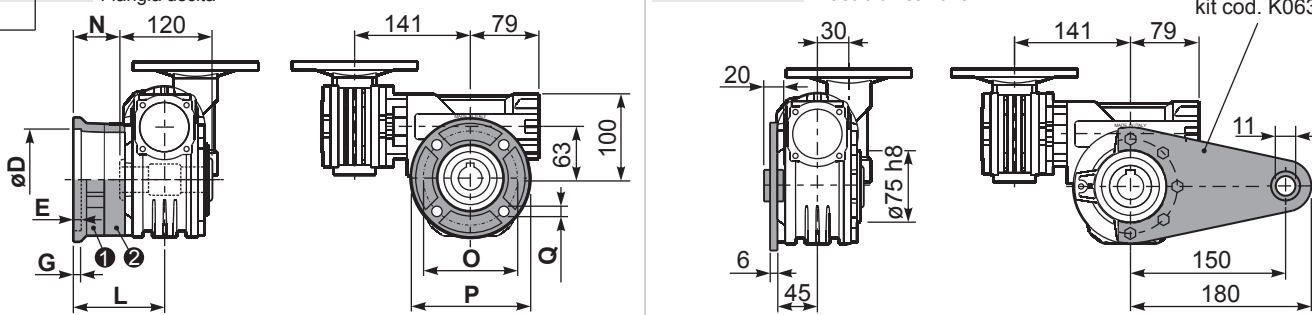

type B	øD	E	G	L	N	O	P	Q	kit code
FC	115 <sup>+0.20</sup> / <sub>+0.15</sub>	7	13	86	26	150	175	11	① K063.9.010 ② -
FL	115 <sup>+0.20</sup> / <sub>+0.15</sub>	7	13	116	56	150	175	11	① K063.9.010 ② K063.0.200
type S	øD	E	G	L	N	O	P	Q	kit code
F1	130 <sup>+0.20</sup> / <sub>+0.15</sub>	7	13	102	42	165	200	13	① KS070.9.013 ② -
F2	115 <sup>+0.20</sup> / <sub>+0.15</sub>	7	13	116	56	150	175	11	① KS063.9.013 ② -
F3	110 <sup>+0.035</sup> / <sub>0</sub>	5	11	82	22	130	160	10	① KS063.9.011 ② -

P633.....**S**... Single Shaft  
Albero lento semplice

P633.....**D**... Double Shaft  
Albero lento bisp.

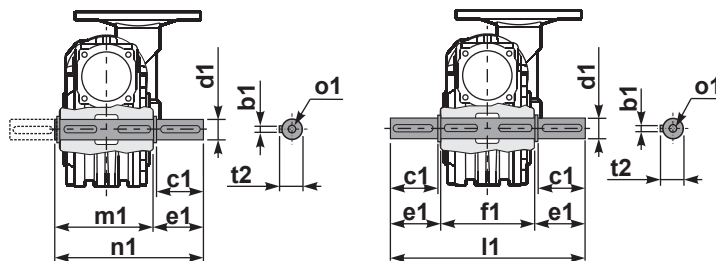

① kit cod. K063.5.028 type B

② kit cod. K063.5.029 type B

R633**FB**... Input shaft  
Albero in entrata

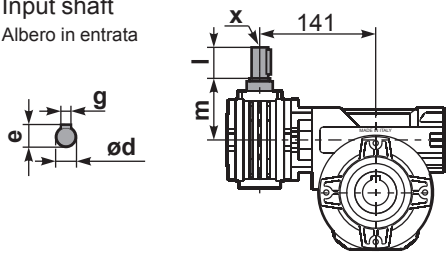

	ød	e	g	l	m	x	kit code
type B	9 h6	10.2	3	20	58	-	① K030.5.006 PAM63 ② -
type S	-	-	-	-	-	-	① - ② -

	b1	c1	d1	e1	f1	l1	m1	n1	t2	o1
type B	8	60	25 <sup>-0.005</sup> / <sub>-0.020</sub>	63.2	120	246.4	126.8	190	28	M8x20
type S	-	-	-	-	-	-	-	-	-	-

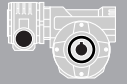

#### QUICK SELECTION / Selezione veloce

input speed ( $n_1$ ) = 1400 min<sup>-1</sup>

Output Speed $n_2$ [min <sup>-1</sup> ]	Ratio $i$	Motor power $P_{1M}$ [kW]	Output torque $M_{2M}$ [Nm]	Service factor f.s.	Nominal power $P_{1R}$ [kW]	Nominal torque $M_{2R}$ [Nm]	Available B5 motor flanges		Available B14 motor flanges			Dynamic efficiency <b>RD</b>	Tooth Module [mm]	Ratios code
							-B	-C	-O	-P	-Q			
							63	71	56	63	71			
5.6	<b>252</b>	0.25	198	1.3	<b>0.33</b>	<b>265</b>	<b>B</b>		B-C	B-C		46	2.7	01
3.9	<b>360</b>	0.18	186	1.4	<b>0.26</b>	<b>265</b>	<b>B</b>		B-C	B-C		42	2.7	02
2.8	<b>504</b>	0.18	241	1.1	<b>0.20</b>	<b>265</b>	<b>B</b>		B-C	B-C		39	2.7	03
1.9	<b>756</b>	0.12	204	1.3	<b>0.16</b>	<b>265</b>	<b>B</b>		B-C	B-C		33	2.7	04
1.4	<b>1008</b>	0.12	256	1.0	<b>0.12</b>	<b>265</b>	<b>B</b>		B-C	B-C		31	2.7	05
1.1	<b>1332</b>	0.12*	265	<0.8	<b>0.10</b>	<b>265</b>	<b>B</b>		B-C	B-C		30	2.7	06
0.8	<b>1656</b>	0.12*	265	<0.8	<b>0.08</b>	<b>265</b>	<b>B</b>		B-C	B-C		28	2.7	07
0.6	<b>2160</b>	0.12*	265	<0.8	<b>0.07</b>	<b>265</b>	<b>B</b>		B-C	B-C		26	2.7	08
0.6	<b>2520</b>	0.12*	265	<0.8	<b>0.06</b>	<b>265</b>	<b>B</b>		B-C	B-C		25	2.7	09

**Motor Flanges Available**  
Flange Motore Disponibili

**B) Supplied with Reduction Bushing**  
Fornito con Bussola di Riduzione

**B) Available on Request without reduction bushing**  
Disponibile a Richiesta senza Bussola di Riduzione

**C) Motor Flange Holes Position**  
Posizione Fori Flangia Motore

\* Power higher than the maximum one which can be supported by the gearbox. Select according to the torque  $M_{2R}$   
Potenza superiore a quella massima sopportabile dal riduttore. Selezionare in base al momento torcente  $M_{2R}$

**EN** Unit 634 is supplied with synthetic oil, providing "long life" lubrication. For mounting position V5-V6 please contact us. See table 1 for lubrication and recommended quantity. In table 2 please see possible radial loads and axial loads on the gearbox.

**I** Il riduttore tipo 634 viene fornito lubrificato a vita con olio sintetico. Per posizioni V5-V6 contattare il ns. servizio tecnico. Vedi tab.1 per oli e quantità consigliati. In tab.2 sono presenti i carichi radiali e assiali applicabili al riduttore.

**D** Für die Lebensdauerschmierung ist das Getriebe der Größe 634 mit synthetischem Öl befüllt. Bei Einbaulage V5 oder V6 bitten wir um Rücksprache. In Tabelle 1 ist die Schmiermenge und das empfohlene Schmiermittel angegeben. In Tabelle 2 sind die zulässigen Radial- und Axialbelastungen des Getriebes aufgeführt.

**F** Le réducteur de type 634 est fourni lubrifié à vie avec de l'huile synthétique. Concernant les positions V5.V6, contactez notre service d'assistance technique. Voir tableau 1 concernant les huiles et les quantités conseillées. Les charges radiales et axiales applicables au réducteur sont précisées dans le tableau 2.

**E** El reductor tamaño 634 se suministra, lubricado de por vida con aceite sintético. Para las posiciones V5 y V6 contactar con nuestro servicio técnico. Ver tabla 1, para cantidades y aceites recomendados. En la tabla 2, se encuentran las cargas radiales y axiales admitidas por el reductor.

**LUBRICATION 634 Oil** 0.40 Lt. 0.09 Lt.

**Quantity 0.40/0.09 Lt.**

**AGIP** Telium VSF 320      **SHELL** Omala S4 WE 320

For all details on lubrication and plugs check our website **tab. 1**  
Per maggiori dettagli su lubrificazione e tappi olio vedi il nostro sito web

#### RADIAL AND AXIAL LOADS

##### Output shaft

Albero di uscita

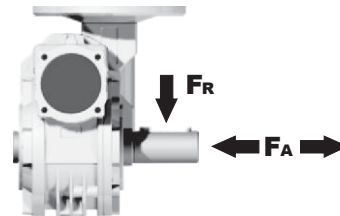

$n_2$ [min <sup>-1</sup> ]	FA [N]	FR [N]
25	700	3800
15	800	4000

##### Input shaft

albero in entrata

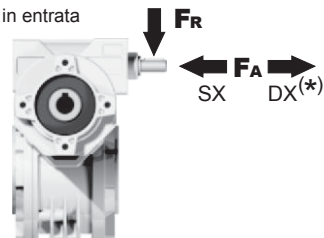

$n_1$ [min <sup>-1</sup> ]	FA [N]	FR [N]
1400	42	210

\*Strong axial loads in the DX direction are not allowed.  
Non sono consentiti forti carichi assiali con direzione DX

tab. 2

3D dimensions on request

P634**FB**...

Basic wormbox  
Riduttore base

Gearbox weight  
peso riduttore **8.90 kg**

M. flanges	Kit code	øF	A
63B5	K050.4.041	138	74
71B5	K050.4.042	160	71.5
56B14	KC40.4.049	80	71.5
63B14	K050.4.047	90	74
71B14	K050.4.045	105	71.5

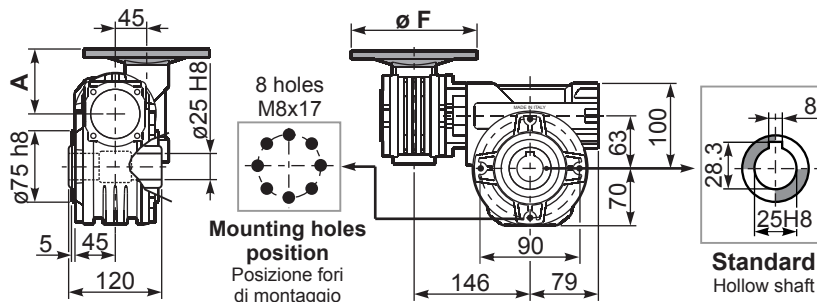

8 holes  
M8x17  
Mounting holes  
position  
Posizione fori  
di montaggio

Standard  
Hollow shaft

P634**PA**...

Feet  
Piedini

P634**PB**...

Feet  
Piedini

P634**PV**...

Feet  
Piedini

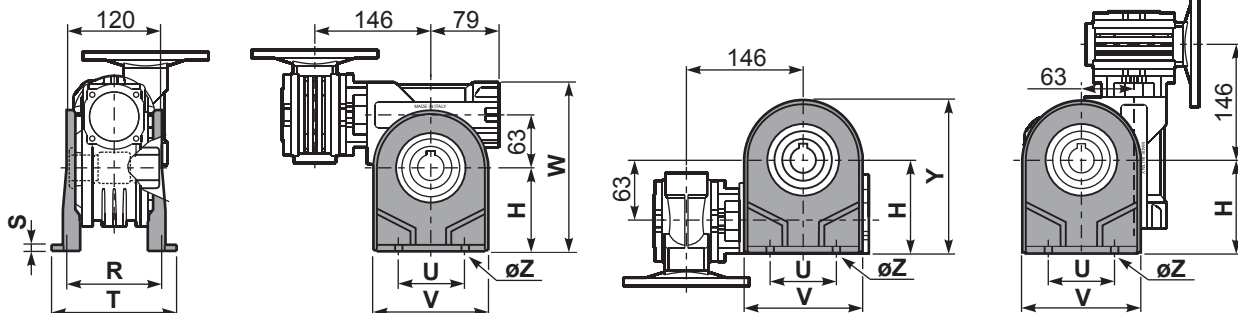

	H	R	S	T	U	V	Y	W	øZ	kit code
type B	100	111	4	144	95	133	170	200	ø10.5	K063.9.022
type S	-	-	-	-	-	-	-	-	-	-

P634**FC**...

Output flange  
Flangia uscita

P634**BR**...

Reaction arm  
Braccio di reazione

kit cod. K063.9.027

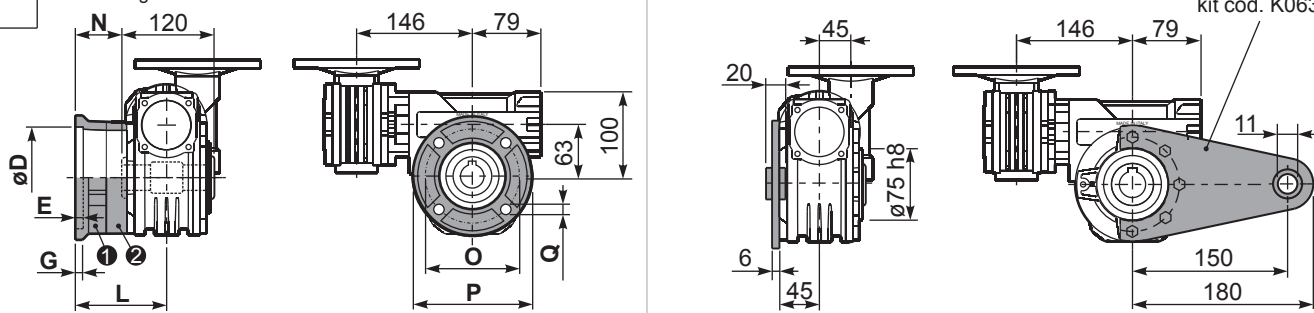

type B	øD	E	G	L	N	O	P	Q	kit code
FC	115 <sup>+0.20</sup> / <sub>+0.15</sub>	7	13	86	26	150	175	11	① K063.9.010 ② -
FL	115 <sup>+0.20</sup> / <sub>+0.15</sub>	7	13	116	56	150	175	11	① K063.9.010 ② K063.0.200

type S	øD	E	G	L	N	O	P	Q	kit code
F1	130 <sup>+0.20</sup> / <sub>+0.15</sub>	7	13	102	42	165	200	13	① KS070.9.013 ② -
F2	115 <sup>+0.20</sup> / <sub>+0.15</sub>	7	13	116	56	150	175	11	① KS063.9.013 ② -
F3	110 <sup>+0.035</sup> / <sub>0</sub>	5	11	82	22	130	160	10	① KS063.9.011 ② -

P634.....**S**...

Single Shaft  
Albero lento semplice

P634.....**D**...

Double Shaft  
Albero lento bisp.

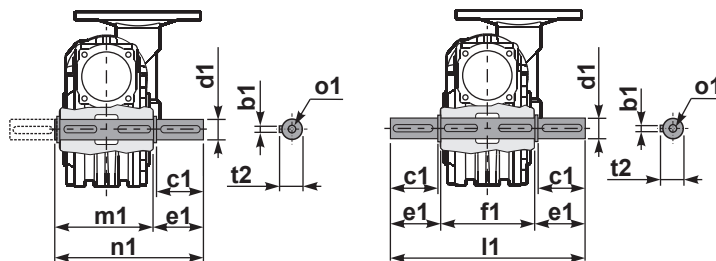

① kit cod. K063.5.028 type B

② kit cod. K063.5.029 type B

R634**FB**...

Input shaft  
Albero in entrata

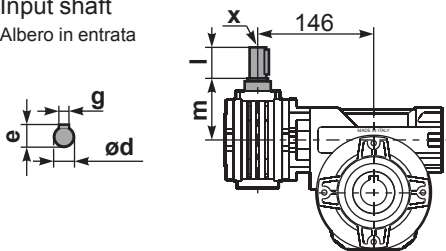

	ød	e	g	l	m	x	kit code
type B	11 h6	12.5	4	30	68	-	① ② K045.5.006 PAM71
type S	-	-	-	-	-	-	① ② -

	b1	c1	d1	e1	f1	l1	m1	n1	t2	o1
type B	8	60	25 <sup>-0.005</sup> / <sub>-0.020</sub>	63.2	120	246.4	126.8	190	28	M8x20
type S	-	-	-	-	-	-	-	-	-	-

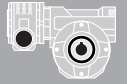

#### QUICK SELECTION / Selezione veloce

input speed ( $n_1$ ) = 1400 min<sup>-1</sup>

Output Speed $n_2$ [min <sup>-1</sup> ]	Ratio $i$	Motor power $P_{1M}$ [kW]	Output torque $M_{2M}$ [Nm]	Service factor f.s.	Nominal power $P_{1R}$ [kW]	Nominal torque $M_{2R}$ [Nm]	Available B5 motor flanges		Available B14 motor flanges		Dynamic efficiency <b>RD</b>	Tooth Module  [mm]	Ratios code 
							-A	-B	-O	-P			
							56	63	56	63			
5.6	<b>252</b>	0.18	142	2.0	<b>0.37</b>	<b>290</b>	B		B-C		46	2.7	01
3.9	<b>360</b>	0.18	181	1.6	<b>0.29</b>	<b>290</b>	B		B-C		41	2.7	02
2.6	<b>540</b>	0.18	245	1.2	<b>0.21</b>	<b>290</b>	B		B-C		37	2.7	03
1.9	<b>720</b>	0.12	200	1.4	<b>0.17</b>	<b>290</b>	B		B-C		34	2.7	04
1.3	<b>1080</b>	0.12	265	1.1	<b>0.13</b>	<b>290</b>	B		B-C		30	2.7	05
1.0	<b>1440</b>	0.12	318	0.9	<b>0.11</b>	<b>290</b>	B		B-C		27	2.7	06
0.5	<b>2745</b>	0.12*	242	<0.8	<b>0.06</b>	<b>242</b>	B		B-C		23	2.1	07

**A) Motor Flanges Available**  
Flange Motore Disponibili

**B) Supplied with Reduction Bushing**  
Fornito con Bussola di Riduzione

**B) Available on Request without reduction bushing**  
Disponibile a Richiesta senza Bussola di Riduzione

**C) Motor Flange Holes Position**  
Posizione Fori Flangia Motore

\* Power higher than the maximum one which can be supported by the gearbox. Select according to the torque  $M_{2R}$   
Potenza superiore a quella massima sopportabile dal riduttore. Selezionare in base al momento torcente  $M_{2R}$

**EN** Unit **6A3** is supplied with synthetic oil, providing "long life" lubrication. For mounting position V5-V6 please contact us. See table 1 for lubrication and recommended quantity. In table 2 please see possible radial loads and axial loads on the gearbox.

**I** Il riduttore tipo **6A3** viene fornito lubrificato a vita con olio sintetico. Per posizioni V5-V6 contattare il ns. servizio tecnico. Vedi tab.1 per oli e quantità consigliati. In tab.2 sono presenti i carichi radiali e assiali applicabili al riduttore.

**D** Für die Lebensdauerschmierung ist das Getriebe der Größe **6A3** mit synthetischem Öl befüllt. Bei Einbaulage V5 oder V6 bitten wir um Rücksprache. In Tabelle 1 ist die Schmiermenge und das empfohlene Schmiermittel angegeben. In Tabelle 2 sind die zulässigen Radial - und Axialbelastungen des Getriebes aufgeführt.

**F** Le réducteur de type **6A3** est fourni lubrifié à vie avec de l'huile synthétique. Concernant les positions V5.V6, contactez notre service d'assistance technique. Voir tableau 1 concernant les huiles et les quantités conseillées. Les charges radiales et axiales applicables au réducteur sont précisées dans le tableau 2.

**E** El reductor tamaño **6A3** se suministra, lubricado de por vida con aceite sintético. Para las posiciones V5 y V6 contactar con nuestro servicio técnico. Ver tabla 1, para cantidades y aceites recomendados. En la tabla 2, se encuentran las cargas radiales y axiales admitidas por el reductor.

**LUBRICATION 6A3 Oil** 0.40 Lt. 0.03 Lt.

**Quantity 0.40/0.03 Lt.**

<b>AGIP</b> Telium VSF 320	<b>SHELL</b> Omala S4 WE 320
----------------------------	------------------------------

For all details on lubrication and plugs check our website **tab. 1**  
Per maggiori dettagli su lubrificazione e tappi olio vedi il nostro sito web

### RADIAL AND AXIAL LOADS

**Output shaft**  
Albero di uscita

$n_2$ [min <sup>-1</sup> ]	FA [N]	FR [N]
25	700	3800
15	800	4000

**Input shaft**  
albero in entrata

$n_1$ [min <sup>-1</sup> ]	FA [N]	FR [N]
1400	20	100

\*Strong axial loads in the DX direction are not allowed.  
Non sono consentiti forti carichi assiali con direzione DX

**tab. 2**

3D dimensions on request

**P6A3FB...** Basic wormbox  
Riduttore base

M. flanges	Kit code	øF	A
56B5	K030.4.041	120	61.5
63B5	K030.4.042	140	62.5
56B14	K030.4.046	80	61.5
63B14	K030.4.045	90	62.5

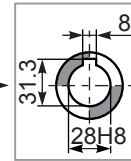
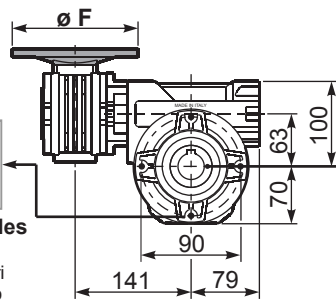
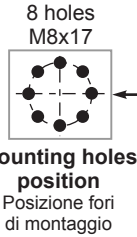
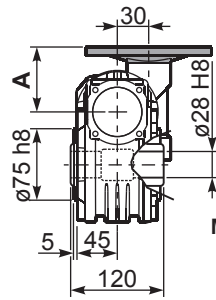

Standard  
Hollow shaft

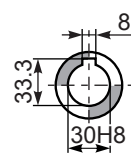

On request  
A richiesta

Gearbox weight  
peso riduttore **8.90 kg**

**P6A3PA...** Feet  
Piedini

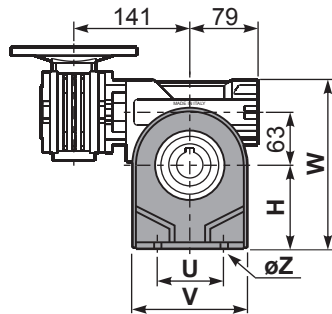
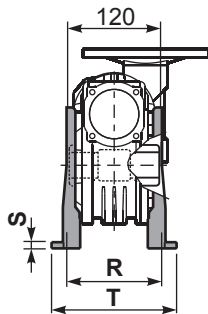

**P6A3PB...** Feet  
Piedini

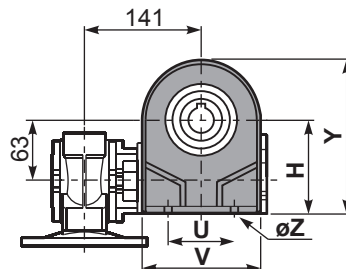

**P6A3PV...** Feet  
Piedini

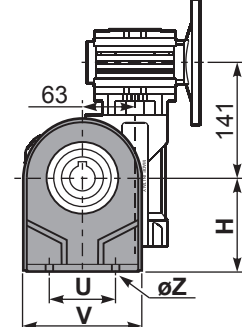

	H	R	S	T	U	V	Y	W	øZ	kit code
type B	115	115	12	142	120	156	185	215	ø11	K070.9.022
type S	-	-	-	-	-	-	-	-	-	-

**P6A3FC...** Output flange  
Flangia uscita

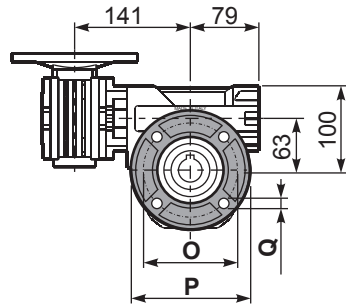
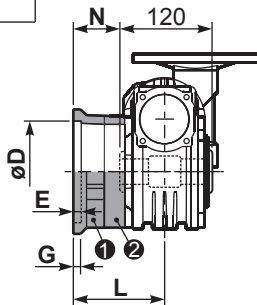

type B	øD	E	G	L	N	O	P	Q	kit code
FC	130 <sup>+0.20</sup> / <sub>+0.15</sub>	7	13	85	25	165	200	13	1 K070.9.010 2 -
FL	130 <sup>+0.20</sup> / <sub>+0.15</sub>	7	13	111	51	165	200	13	1 K070.9.010 2 K070.0.200
type S	øD	E	G	L	N	O	P	Q	kit code
F1	130 <sup>+0.20</sup> / <sub>+0.15</sub>	7	13	111	51	165	200	13	1 KS070.9.014 2 -
F2	115 <sup>+0.20</sup> / <sub>+0.15</sub>	7	13	116	56	150	175	11	1 KS063.9.013 2 -
F3	110 <sup>+0.035</sup> / <sub>0</sub>	5	13.5	84.5	24.5	130	160	11	1 KS070.9.011 2 -

**P6A3BR...** Reaction arm  
Braccio di reazione

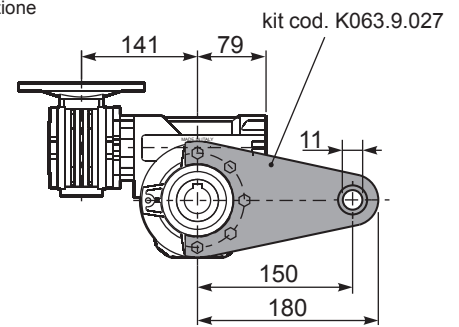
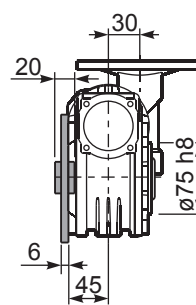

**P6A3....S...** Single Shaft  
Albero lento semplice

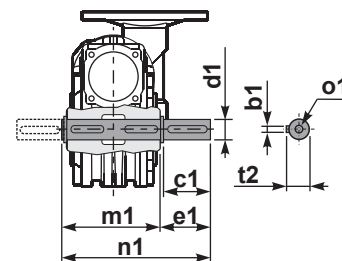

**P6A3....D...** Double Shaft  
Albero lento bisp.

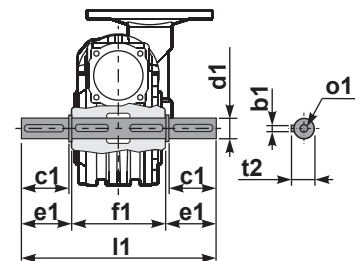

1 kit cod. K070.5.028 type B

2 kit cod. K070.5.029 type B

**R6A3FB...** Input shaft  
Albero in entrata

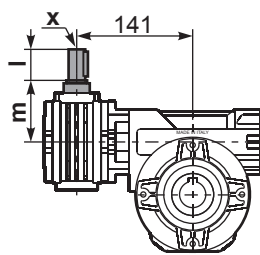
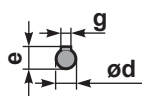

	ød	e	g	l	m	x	kit code
type B	9 h6	10.2	3	20	58	-	1 K030.5.006 PAM63 2 -
type S	-	-	-	-	-	-	1 - 2 -

	b1	c1	d1	e1	f1	l1	m1	n1	t2	o1
type B	8	60	28 <sup>-0.005</sup> / <sub>-0.020</sub>	63.5	120	247	127.5	191	31	M8x20
type S	-	-	-	-	-	-	-	-	-	-

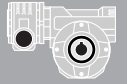

#### QUICK SELECTION / Selezione veloce

input speed ( $n_1$ ) = 1400 min<sup>-1</sup>

Output Speed $n_2$ [min <sup>-1</sup> ]	Ratio $i$	Motor power $P_{1M}$ [kW]	Output torque $M_{2M}$ [Nm]	Service factor f.s.	Nominal power $P_{1R}$ [kW]	Nominal torque $M_{2R}$ [Nm]	Available B5 motor flanges		Available B14 motor flanges			Dynamic efficiency <b>RD</b>	Tooth Module [mm]	Ratios code
							-B	-C	-O	-P	-Q			
							63	71	56	63	71			
5.6	<b>252</b>	0.25	198	1.5	<b>0.38</b>	<b>304</b>	<b>B</b>		B-C	B-C		46	2.7	01
3.9	<b>360</b>	0.25	258	1.2	<b>0.29</b>	<b>304</b>	<b>B</b>		B-C	B-C		42	2.7	02
2.8	<b>504</b>	0.18	241	1.3	<b>0.23</b>	<b>304</b>	<b>B</b>		B-C	B-C		39	2.7	03
1.9	<b>756</b>	0.12	204	1.5	<b>0.18</b>	<b>304</b>	<b>B</b>		B-C	B-C		33	2.7	04
1.4	<b>1008</b>	0.12	256	1.2	<b>0.14</b>	<b>304</b>	<b>B</b>		B-C	B-C		31	2.7	05
1.1	<b>1332</b>	0.12	327	0.9	<b>0.11</b>	<b>304</b>	<b>B</b>		B-C	B-C		30	2.7	06
0.8	<b>1656</b>	0.12*	304	<0.8	<b>0.10</b>	<b>304</b>	<b>B</b>		B-C	B-C		28	2.7	07
0.6	<b>2160</b>	0.12*	304	<0.8	<b>0.08</b>	<b>304</b>	<b>B</b>		B-C	B-C		26	2.7	08
0.6	<b>2520</b>	0.12*	304	<0.8	<b>0.07</b>	<b>304</b>	<b>B</b>		B-C	B-C		25	2.7	09

**A) Motor Flanges Available**  
Flange Motore Disponibili

**B) Supplied with Reduction Bushing**  
Fornito con Bussola di Riduzione

**B) Available on Request without reduction bushing**  
Disponibile a Richiesta senza Bussola di Riduzione

**C) Motor Flange Holes Position**  
Posizione Fori Flangia Motore

\* Power higher than the maximum one which can be supported by the gearbox. Select according to the torque  $M_{2R}$   
Potenza superiore a quella massima sopportabile dal riduttore. Selezionare in base al momento torcente  $M_{2R}$

**EN** Unit **6A4** is supplied with synthetic oil, providing "long life" lubrication. For mounting position V5-V6 please contact us. See table 1 for lubrication and recommended quantity. In table 2 please see possible radial loads and axial loads on the gearbox.

**I** Il riduttore tipo **6A4** viene fornito lubrificato a vita con olio sintetico. Per posizioni V5-V6 contattare il ns. servizio tecnico. Vedi tab.1 per oli e quantità consigliati. In tab.2 sono presenti i carichi radiali e assiali applicabili al riduttore.

**D** Für die Lebensdauerschmierung ist das Getriebe der Größe **6A4** mit synthetischem Öl befüllt. Bei Einbaulage V5 oder V6 bitten wir um Rücksprache. In Tabelle 1 ist die Schmiermenge und das empfohlene Schmiermittel angegeben. In Tabelle 2 sind die zulässigen Radial- und Axialbelastungen des Getriebes aufgeführt.

**F** Le réducteur de type **6A4** est fourni lubrifié à vie avec de l'huile synthétique. Concernant les positions V5.V6, contactez notre service d'assistance technique. Voir tableau 1 concernant les huiles et les quantités conseillées. Les charges radiales et axiales applicables au réducteur sont précisées dans le tableau 2.

**E** El reductor tamaño **6A4** se suministra, lubricado de por vida con aceite sintético. Para las posiciones V5 y V6 contactar con nuestro servicio técnico. Ver tabla 1, para cantidades y aceites recomendados. En la tabla 2, se encuentran las cargas radiales y axiales admitidas por el reductor.

**■ LUBRICATION 6A4 Oil** 0.40 Lt.

**Quantity 0.40/0.09 Lt.**  0.09 Lt.

<b>AGIP</b> Telium VSF 320	<b>SHELL</b> Omala S4 WE 320
----------------------------	------------------------------

For all details on lubrication and plugs check our website tab. 1  
Per maggiori dettagli su lubrificazione e tappi olio vedi il nostro sito web

### ■ RADIAL AND AXIAL LOADS

**Output shaft**  
Albero di uscita

$n_2$ [min <sup>-1</sup> ]	FA [N]	FR [N]
<b>25</b>	700	3800
<b>15</b>	800	4000

**Input shaft**  
albero in entrata

$n_1$ [min <sup>-1</sup> ]	FA [N]	FR [N]
<b>1400</b>	42	210

\*Strong axial loads in the DX direction are not allowed.  
Non sono consentiti forti carichi assiali con direzione DX

tab. 2

3D dimensions on request

**P6A4FB...** Basic wormbox  
Riduttore base

M. flanges	Kit code	øF	A
63B5	K050.4.041	138	74
71B5	K050.4.042	160	71.5
56B14	KC40.4.049	80	71.5
63B14	K050.4.047	90	74
71B14	K050.4.045	105	71.5

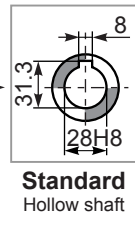
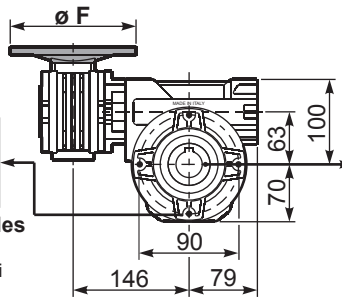
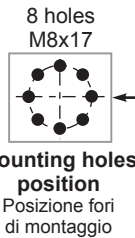
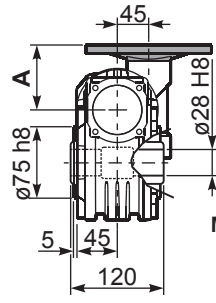

Gearbox weight  
peso riduttore **8.90 kg**

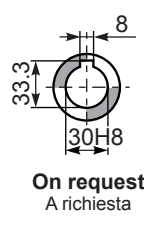

**Standard**  
Hollow shaft

**On request**  
A richiesta

**P6A4PA...** Feet  
Piedini

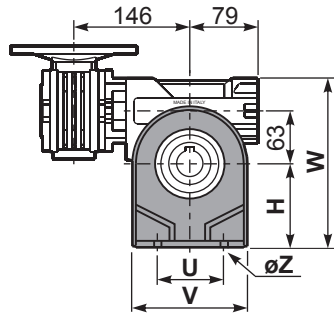
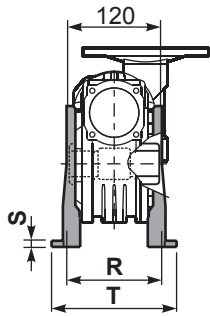

**P6A4PB...** Feet  
Piedini

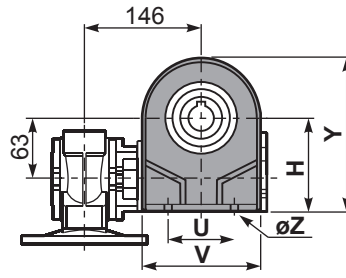

**P6A4PV...** Feet  
Piedini

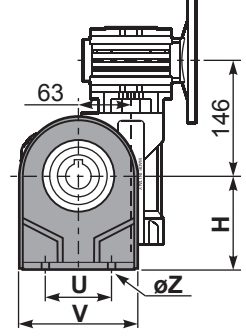

	H	R	S	T	U	V	Y	W	øZ	kit code
type B	115	115	12	142	120	156	185	215	ø11	K070.9.022
type S	-	-	-	-	-	-	-	-	-	-

**P6A4FC...** Output flange  
Flangia uscita

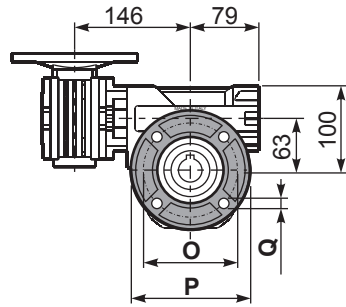
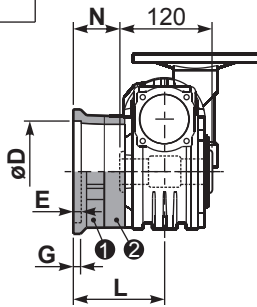

type B	øD	E	G	L	N	O	P	Q	kit code
FC	130 <sup>+0.20</sup> / <sub>+0.15</sub>	7	13	85	25	165	200	13	1 K070.9.010 2 -
FL	130 <sup>+0.20</sup> / <sub>+0.15</sub>	7	13	111	51	165	200	13	1 K070.9.010 2 K070.0.200
type S	øD	E	G	L	N	O	P	Q	kit code
F1	130 <sup>+0.20</sup> / <sub>+0.15</sub>	7	13	111	51	165	200	13	1 KS070.9.014 2 -
F2	115 <sup>+0.20</sup> / <sub>+0.15</sub>	7	13	116	56	150	175	11	1 KS063.9.013 2 -
F3	110 <sup>+0.035</sup> / <sub>0</sub>	5	13.5	84.5	24.5	130	160	11	1 KS070.9.011 2 -

**P6A4BR...** Reaction arm  
Braccio di reazione

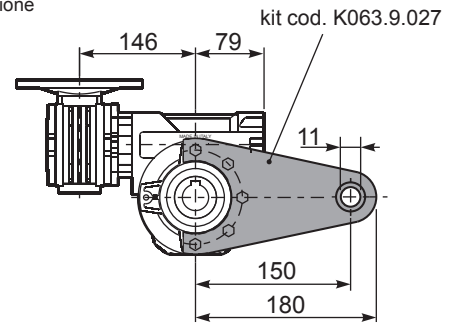
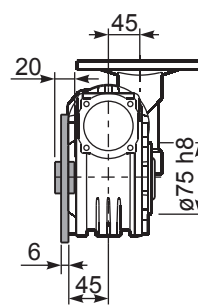

**P6A4....S...** Single Shaft  
Albero lento semplice

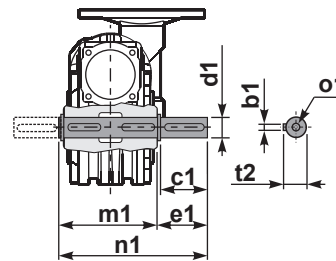

**P6A4....D...** Double Shaft  
Albero lento bisp.

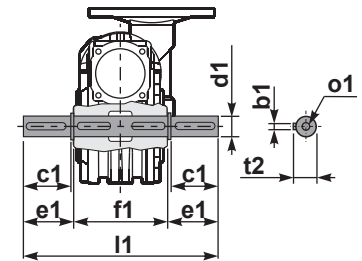

1 kit cod. K070.5.028 type B

2 kit cod. K070.5.029 type B

**R6A4FB...** Input shaft  
Albero in entrata

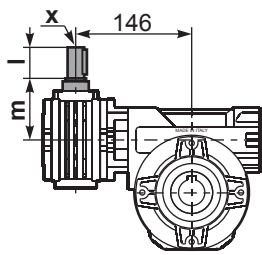
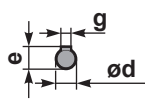

	ød	e	g	l	m	x	kit code
type B	11 h6	12.5	4	30	68	-	1 2 K045.5.006 PAM71
type S	-	-	-	-	-	-	1 2 -

	b1	c1	d1	e1	f1	l1	m1	n1	t2	o1
type B	8	60	28 <sup>-0.005</sup> / <sub>-0.020</sub>	63.5	120	247	127.5	191	31	M8x20
type S	-	-	-	-	-	-	-	-	-	-

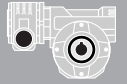

#### QUICK SELECTION / Selezione veloce

input speed ( $n_1$ ) = 1400 min<sup>-1</sup>

Output Speed $n_2$ [min <sup>-1</sup> ]	Ratio $i$	Motor power $P_{1M}$ [kW]	Output torque $M_{2M}$ [Nm]	Service factor f.s.	Nominal power $P_{1R}$ [kW]	Nominal torque $M_{2R}$ [Nm]	Available B5 motor flanges		Available B14 motor flanges			Dynamic efficiency <b>RD</b>	Tooth Module [mm]	Ratios code
							-B	-C	-O	-P	-Q			
							63	71	56	63	71			
10	<b>140</b>	0.37	205	1.8	<b>0.66</b>	<b>368</b>	<b>B</b>		B-C	B-C		58	4.5	01
7.1	<b>196</b>	0.37	257	1.4	<b>0.53</b>	<b>368</b>	<b>B</b>		B-C	B-C		52	4.7	02
5.0	<b>280</b>	0.37	332	1.6	<b>0.58</b>	<b>518</b>	<b>B</b>		B-C	B-C		47	4.7	03
3.6	<b>392</b>	0.37	435	1.2	<b>0.44</b>	<b>518</b>	<b>B</b>		B-C	B-C		44	4.7	04
2.4	<b>588</b>	0.25	371	1.4	<b>0.35</b>	<b>518</b>	<b>B</b>		B-C	B-C		37	4.7	05
1.8	<b>784</b>	0.25	455	1.1	<b>0.28</b>	<b>518</b>	<b>B</b>		B-C	B-C		34	4.7	06
1.4	<b>1036</b>	0.18	420	1.2	<b>0.22</b>	<b>518</b>	<b>B</b>		B-C	B-C		33	4.7	07
1.1	<b>1288</b>	0.18	474	1.1	<b>0.20</b>	<b>518</b>	<b>B</b>		B-C	B-C		30	4.7	08
0.7	<b>1960</b>	0.12	449	1.2	<b>0.14</b>	<b>518</b>	<b>B</b>		B-C	B-C		28	4.7	09
0.5	<b>2856</b>	0.12	584	0.9	<b>0.11</b>	<b>518</b>	<b>B</b>		B-C	B-C		25	4.7	10

**A** Motor Flanges Available  
Flange Motore Disponibili

**B** Supplied with Reduction Bushing  
Fornito con Bussola di Riduzione

**B** Available on Request without reduction bushing  
Disponibile a Richiesta senza Bussola di Riduzione

**C** Motor Flange Holes Position  
Posizione Fori Flangia Motore

**EN** Unit **854** is supplied with synthetic oil, providing "long life" lubrication. For mounting position V5-V6 please contact us. See table 1 for lubrication and recommended quantity. In table 2 please see possible radial loads and axial loads on the gearbox.

**I** Il riduttore tipo **854** viene fornito lubrificato a vita con olio sintetico. Per posizioni V5-V6 contattare il ns. servizio tecnico. Vedi tab.1 per oli e quantità consigliati. In tab.2 sono presenti i carichi radiali e assiali applicabili al riduttore.

**D** Für die Lebensdauerschmierung ist das Getriebe der Größe **854** mit synthetischem Öl befüllt. Bei Einbaulage V5 oder V6 bitten wir um Rücksprache. In Tabelle 1 ist die Schmiermenge und das empfohlene Schmiermittel angegeben. In Tabelle 2 sind die zulässigen Radial- und Axialbelastungen des Getriebes aufgeführt.

**F** Le réducteur de type **854** est fourni lubrifié à vie avec de l'huile synthétique. Concernant les positions V5.V6, contactez notre service d'assistance technique. Voir tableau 1 concernant les huiles et les quantités conseillées. Les charges radiales et axiales applicables au réducteur sont précisées dans le tableau 2.

**E** El reductor tamaño **854** se suministra, lubricado de por vida con aceite sintético. Para las posiciones V5 y V6 contactar con nuestro servicio técnico. Ver tabla 1, para cantidades y aceites recomendados. En la tabla 2, se encuentran las cargas radiales y axiales admitidas por el reductor.

**LUBRICATION 854 Oil** **1.2 Lt.**

**Quantity 1.2/0.09 Lt.**

**AGIP** Telium VSF 320

**SHELL** Omala S4 WE 320

For all details on lubrication and plugs check our website **tab. 1**  
Per maggiori dettagli su lubrificazione e tappi olio vedi il nostro sito web

#### RADIAL AND AXIAL LOADS

##### Output shaft

Albero di uscita

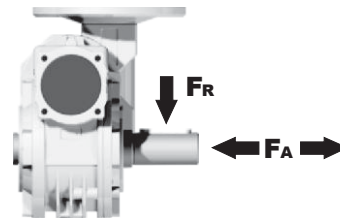

$n_2$ [min <sup>-1</sup> ]	FA [N]	FR [N]
<b>25</b>	1000	5000
<b>15</b>	1160	5800

##### Input shaft

albero in entrata

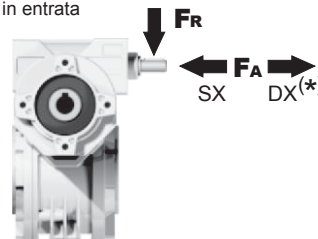

$n_1$ [min <sup>-1</sup> ]	FA [N]	FR [N]
<b>1400</b>	42	210

**\*Strong axial loads in the DX direction are not allowed.**  
Non sono consentiti forti carichi assiali con direzione DX

**tab. 2**



3D dimensions on request

**P854FB...** Basic wormbox  
Riduttore base

M. flanges	Kit code	øF	A
<b>63B5</b>	K050.4.041	138	74
<b>71B5</b>	K050.4.042	160	71.5
<b>56B14</b>	KC40.4.049	80	71.5
<b>63B14</b>	K050.4.047	90	74
<b>71B14</b>	K050.4.045	105	71.5

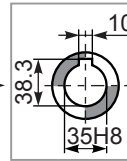
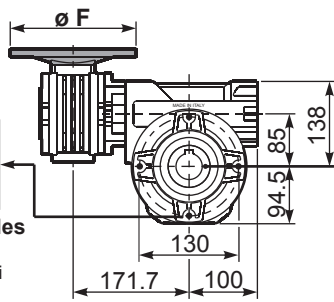
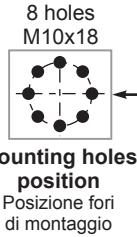
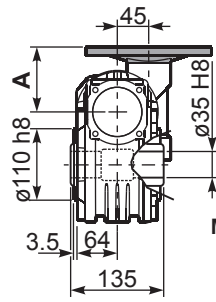

**Standard**  
Hollow shaft

Gearbox weight  
peso riduttore **19.50 kg**

**P854PA...** Feet  
Piedini

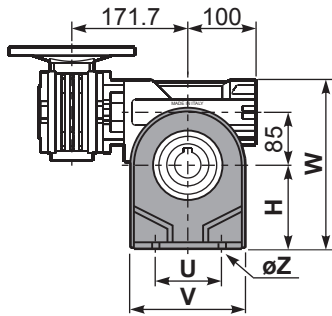
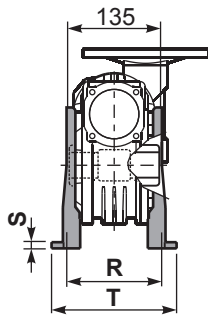

**P854PB...** Feet  
Piedini

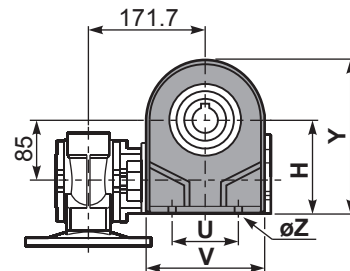

**P854PV...** Feet  
Piedini

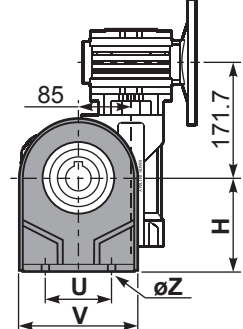

	H	R	S	T	U	V	Y	W	øZ	kit code
type B	142	145	5	182	140	180	236.5	280	ø10.5	K085.9.022
type S	-	-	-	-	-	-	-	-	-	-

**P854FC...** Output flange  
Flangia uscita

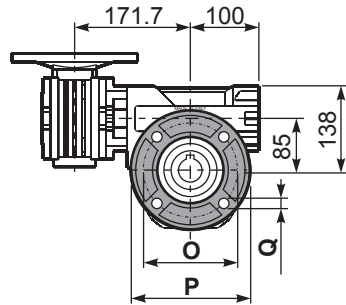
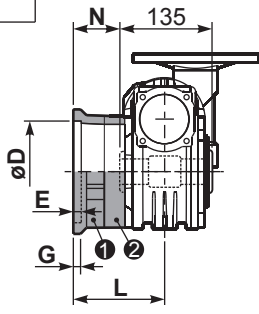

**P854BR...** Reaction arm  
Braccio di reazione

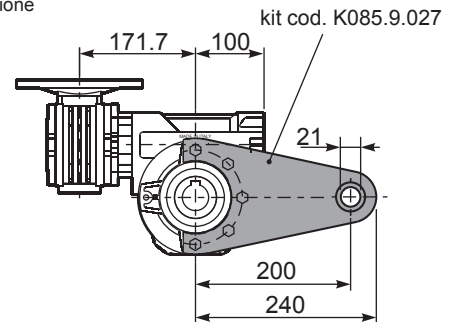
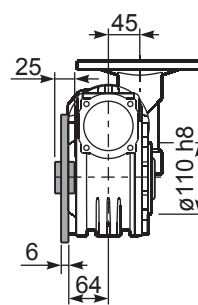

type B	øD	E	G	L	N	O	P	Q	kit code
<b>FC</b>	152 <sup>+0.06</sup> / <sub>+0.00</sub>	5	16	108	40.5	176	205	13	1, 2 K085.9.010
<b>FL</b>	152 <sup>+0.06</sup> / <sub>+0.00</sub>	5	16	148.5	81	176	205	13	1, 2 K085.9.010 2 K085.0.201
type S	øD	E	G	L	N	O	P	Q	kit code
<b>F1</b>	130 <sup>+0.040</sup> / <sub>0</sub>	5	13	117.5	50	165	200	11.5	1, 2 KS085.9.012
<b>F2</b>	152 <sup>+0.06</sup> / <sub>0</sub>	5	15	147.5	80	180	205	12.5	1, 2 KS085.9.013
<b>F4</b>	130 <sup>+0.040</sup> / <sub>0</sub>	5	13	106.5	39	165	200	13	1, 2 KS085.9.015

**P854.....S...** Single Shaft  
Albero lento semplice

**P854.....D...** Double Shaft  
Albero lento bisp.

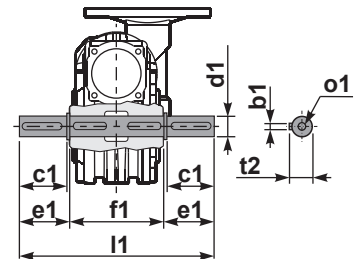
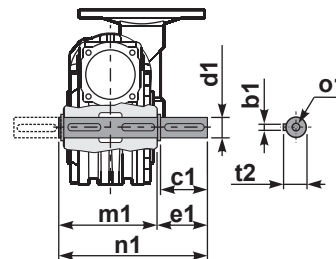

1 kit cod. K085.5.028 type B

2 kit cod. K085.5.029 type B

**R854FB...** Input shaft  
Albero in entrata

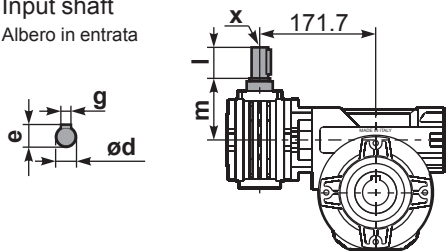

	ød	e	g	l	m	x	kit code
type B	11 h6	12.5	4	30	68	-	1, 2 K045.5.006 PAM71
type S	-	-	-	-	-	-	1, 2 -

	b1	c1	d1	e1	f1	l1	m1	n1	t2	o1
type B	10	60	35 <sup>-0.005</sup> / <sub>-0.020</sub>	73.5	135	282	141	214.5	38	M10x23
type S	-	-	-	-	-	-	-	-	-	-

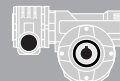

#### QUICK SELECTION / Selezione veloce

input speed ( $n_1$ ) = 1400 min<sup>-1</sup>

Output Speed $n_2$ [min <sup>-1</sup> ]	Ratio $i$	Motor power $P_{1M}$ [kW]	Output torque $M_{2M}$ [Nm]	Service factor f.s.	Nominal power $P_{1R}$ [kW]	Nominal torque $M_{2R}$ [Nm]	Available B5 motor flanges			Available B14 motor flanges				Dynamic efficiency <b>RD</b>	Tooth Module  [mm]	 Ratios code
							-B	-C	-D	-O	-P	-Q	-R			
							63	71	80	56	63	71	80			
6.7	<b>210</b>	0.75	591	1.5	<b>1.1</b>	<b>863</b>	B	B			B-C	B		55	5.6	01
4.7	<b>300</b>	0.75	752	1.3	<b>0.97</b>	<b>978</b>	B	B			B-C	B		49	5.6	02
3.3	<b>420</b>	0.55	741	1.3	<b>0.73</b>	<b>978</b>	B	B			B-C	B		47	5.6	03
2.6	<b>540</b>	0.55	851	1.1	<b>0.63</b>	<b>978</b>	B	B			B-C	B		42	5.6	04
1.8	<b>780</b>	0.37	748	1.3	<b>0.48</b>	<b>978</b>	B	B			B-C	B		38	5.6	05
1.3	<b>1080</b>	0.37	1009	1.0	<b>0.36</b>	<b>978</b>	B			B-C	B-C			37	5.6	06
1.1	<b>1290</b>	0.25	770	1.3	<b>0.32</b>	<b>978</b>	B			B-C	B-C			35	5.6	07
0.8	<b>1800</b>	0.25	921	1.1	<b>0.27</b>	<b>978</b>	B			B-C	B-C			30	5.6	08
0.7	<b>2040</b>	0.18	751	1.3	<b>0.23</b>	<b>978</b>	B			B-C	B-C			30	5.6	09
0.6	<b>2400</b>	0.18	825	1.2	<b>0.21</b>	<b>978</b>	B			B-C	B-C			28	5.6	10
0.5	<b>3000</b>	0.18	958	1.0	<b>0.18</b>	<b>978</b>	B			B-C	B-C			26	5.6	11

**Motor Flanges Available**  
Flange Motore Disponibili

**B) Supplied with Reduction Bushing**  
Fornito con Bussola di Riduzione

**B) Available on Request without reduction bushing**  
Disponibile a Richiesta senza Bussola di Riduzione

**C) Motor Flange Holes Position**  
Posizione Fori Flangia Motore

**EN** Unit 115 is supplied without lubricant and equipped with a breather, level and drain plugs. User can add mineral oil keeping existing plugs. Should the user wish to fill it with synthetic oil, it is recommended to replace the existing plugs with a type that are closed. Gearbox 050 is supplied lubricated for life. See tab.1 for oils and recommended quantity. In tab.2 there are radial loads and axial loads applicable to the gearbox.

**I** Il riduttore tipo 115 è fornito di lubrificazione con tappi di sfiato, livello e scarico olio. L'utente può immettere olio minerale mantenendo i tappi esistenti. Se immetterà olio sintetico, dovrà sostituire i tappi esistenti con altri tipo chiuso. Il riduttore 050 è fornito lubrificato a vita con olio sintetico. Tab.1 per oli e quantità consigliati. Tab.2 carichi radiali e assiali applicabili al riduttore.

**D** Das Getriebe der Baugröße 115 wird ohne Schmiermittel geliefert. Es ist jedoch mit Einfüllschraube, Überdruckventil und Ablassschraube ausgerüstet. Das benötigte mineralische Öl kann über die Einfüllschraube eingefüllt werden. Sollte synthetisches Öl bevorzugt werden, so ist sind das eingebaute Überdruckventil durch eine geschlossenen Schraube zu ersetzen. Das Getriebe der Baugröße 050 ist lebensdauer geschmiert. In Tabelle 1 ist die Schmiermenge und das empfohlene Schmiermittel angegeben. In Tabelle 2 sind die zulässigen Radial - und Axialbelastungen des Getriebes aufgeführt.

**F** Le réducteur de type 115 est fourni sans lubrification et avec un bouchon de remplissage, de niveau et d'évacuation de l'huile. L'utilisateur peut y verser de l'huile minérale en conservant les bouchons existants. S'il y versera de l'huile synthétique, il devra substituer les bouchons existants avec d'autres bouchons de type fermé. Le réducteur de type 050 est fourni lubrifié à vie avec de l'huile synthétique. Voir tableau 1 concernant les huiles et les quantités conseillées. Voir tableau 2 concernant les charges radiales et axiales applicables au réducteur.

**E** El reductor tamaño 115 se suministra sin lubricante, provisto de tapones de respiración, nivel y descarga de aceite. El usuario puede utilizar aceite mineral, manteniendo los tapones existentes. Si prefiere utilizar aceite sintético deberá sustituir los tapones existentes por tapones ciegos. El reductor 050 se suministra lubricado de por vida con aceite sintético. Ver tabla 1, para cantidades y aceites recomendados. En la tabla 2, se encuentran las cargas radiales y axiales admitidas por el reductor.

B3	B6	B7	B8	V5	V6
2.0/0.14 LT	1.35/0.14 LT	1.35/0.14 LT	2.0/0.14 LT	2.0/0.14 LT	2.0/0.14 LT

**AGIP Blasia 460**

For all details on lubrication and plugs check our website [Per maggiori dettagli su lubrificazione e tappi olio vedi il nostro sito web](#) **tab. 1**

#### RADIAL AND AXIAL LOADS

##### Output shaft

Albero di uscita

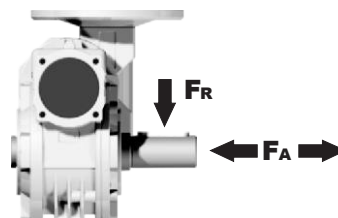

$n_2$ [min <sup>-1</sup> ]	FA [N]	FR [N]
25	1200	6000
15	1400	7000

##### Input shaft

albero in entrata

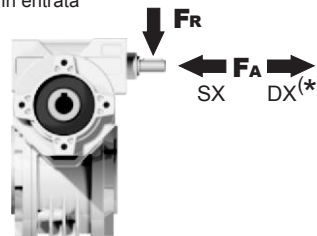

$n_1$ [min <sup>-1</sup> ]	FA [N]	FR [N]
1400	76	380

\*Strong axial loads in the DX direction are not allowed.  
Non sono consentiti forti carichi assiali con direzione DX

**tab. 2**

3D dimensions on request

**P115FB...** Basic wormbox  
Riduttore base

Gearbox weight  
peso riduttore **38.00 kg**

M. flanges	Kit code	øF	A
<b>63B5</b>	K050.4.041	138	78.5
<b>71B5</b>	K050.4.042	160	76
<b>80B5</b>	K050.4.043	200	76.5
<b>56B14</b>	KC40.4.049	80	76
<b>63B14</b>	K050.4.047	90	78.5
<b>71B14</b>	K050.4.045	105	76
<b>80B14</b>	K050.4.046	120	76.5

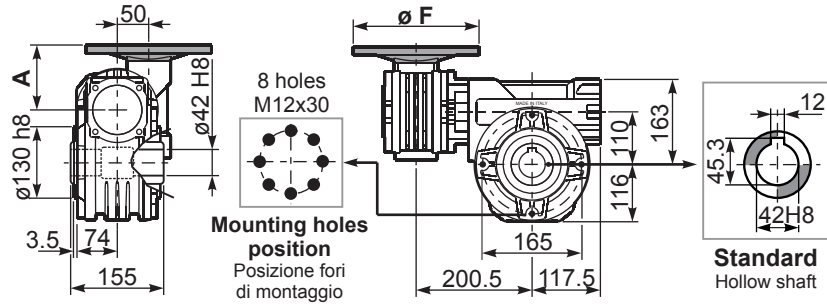

**P115PA...** Feet  
Piedini

**P115PB...** Feet  
Piedini

**P115PV...** Feet  
Piedini

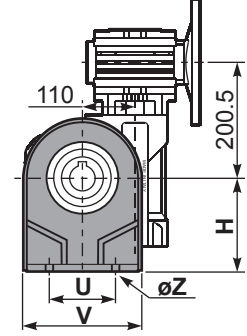
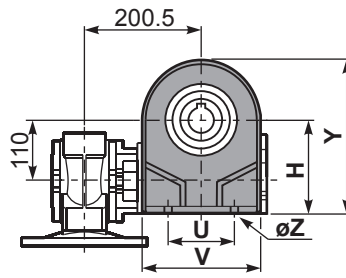
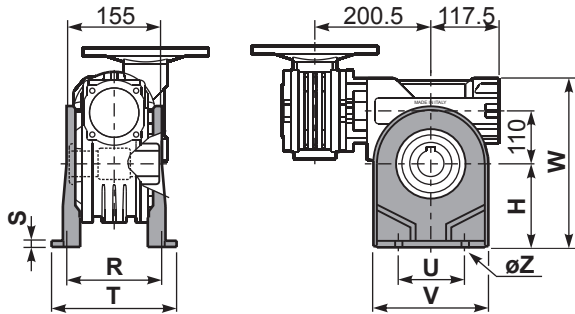

	H	R	S	T	U	V	Y	W	øZ	kit code
type B	170	180	22	224	200	240	286	333	ø13	K110.9.022
type S	172	160	8	204	200	240	288	335	ø14	KS110.9.023

**P115FC...** Output flange  
Flangia uscita

**P115BR...** Reaction arm  
Braccio di reazione

kit cod. K110.9.027

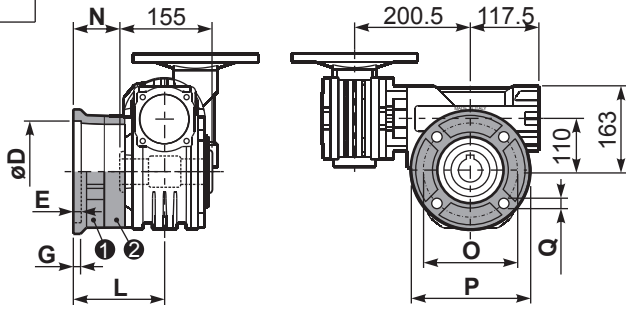

type B	øD	E	G	L	N	O	P	Q	kit code
<b>FC</b>	170 <sup>+0.083</sup> / <sub>+0.043</sub>	11	16.5	131.5	54	230	270	13	1 2 K110.9.010
<b>FL</b>	170 <sup>+0.083</sup> / <sub>+0.043</sub>	11	16.5	179.5	102	230	270	13	1 2 K110.9.011
type S	øD	E	G	L	N	O	P	Q	kit code
<b>F1</b>	180 <sup>+0.040</sup> / <sub>0</sub>	5	18	150	72.5	215	250	15	1 2 KS110.9.014
<b>F2</b>	170 <sup>+0.083</sup> / <sub>+0.043</sub>	9.5	15	178	100.5	230	270	13	1 2 KS110.9.012
<b>F3</b>	180 <sup>+0.040</sup> / <sub>0</sub>	5	18	130	52.5	215	250	15	1 2 KS110.9.013

**P115....S...** Single Shaft  
Albero lento semplice

**P115....D...** Double Shaft  
Albero lento bisp.

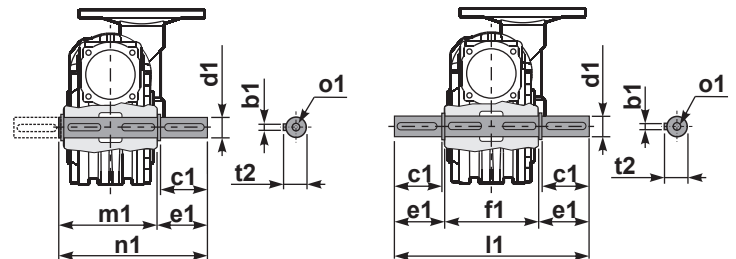

1 kit cod. K110.5.028 type B

2 kit cod. K110.5.029 type B

**R115FB...** Input shaft  
Albero in entrata

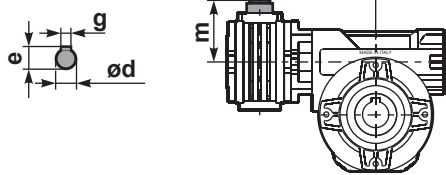

	ød	e	g	l	m	x	kit code
type B	16 h6	18	5	30	74.5	M6x16	1 K050.5.006 PAM71 2 K050.5.007 PAM80
type S	14 h6	16	5	30	74.5	M5x10	1 KS050.5.008 PAM71 2 KS050.5.009 PAM80

	b1	c1	d1	e1	f1	l1	m1	n1	t2	o1
type B	12	75	42 <sup>-0.005</sup> / <sub>-0.020</sub>	96.5	155	348	163.5	260	45	M12x32
type S	-	-	-	-	-	-	-	-	-	-



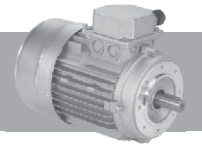

**Protection**

Standard IP55  
Please specify on purchase orders if you need a higher IP protection class.

**Grado di protezione**

IP55 Standard  
Specificare in sede di ordinazione per IP superiore.

**Schutzart**

IP55 Standard.  
Höheren IP Grad bitte im Auftrag angeben.

**Degré de protection**

IP55 standard.  
Au moment de la commande, spécifiez si vous souhaitez IP supérieur.

**Grado de protección**  
IP55 standard.  
Especificar en el pedido cuando necesiten protección IP superior.

**Insulation**

Standard CI.F  
To be specified upon placing the order if different insulation is required.

**Isolamento**

CI.F Standard  
Specificare in sede di ordinazione classe di isolamento diversa.

**Isolierung**

CI.F Standard.  
Davon abweichende Isolierungsklasse im Auftrag angeben.

**Isolement**

CI.F Standard.  
Au moment de la commande, spécifiez si vous souhaitez une classe d'isolement différente.

**Aislamiento**

CI.F standard.  
Especificar al efectuar el pedido la clase diferente de aislamiento.

Insulation / Isolamento Isolierung /Aislamiento		E	B	F	H
Max. temp.	C°	120°	130°	155°	175°
	F*	248°	266°	311°	347°

**Connections**

**Collegamenti**

**Verbindungselemente**

**Branchements**

**Conexiones**

Threephase asynchronous single polarity  
Asincrono trifase singola polarità  
Asynchronmotor 3-ph eine Drehzahl  
Moteur triphasé à une vitesse  
Asincrono trifasico de una velocidad

Threephase asynchronous double polarity  
Asincrono trifase doppia polarità  
Asynchronmotor 3-ph doppelte Drehzahl  
Moteur triphasé à deux vitesses  
Asincrono trifasico de dos velocidades

Single phase asynchronous  
Asincrono monofase  
Einphasen-Asynchronmotor  
Moteur monophasé  
Asincrono monofasico

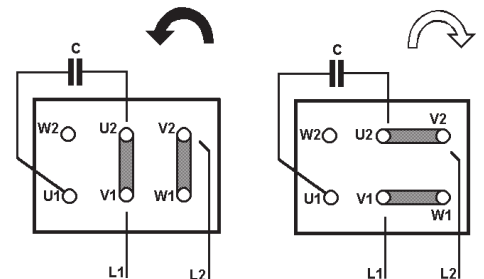
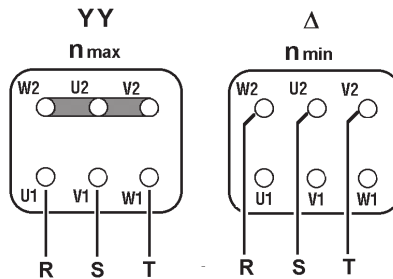
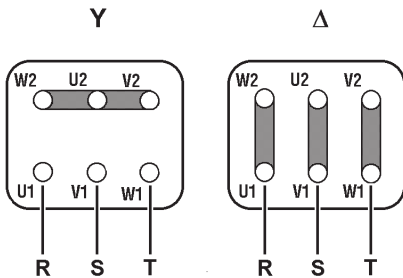



**Please Read Carefully**

The following WARNING and CAUTION information is supplied to you for your protection and to provide you with many years of trouble free and safe operation of your product.

Read ALL instructions prior to operating reducer. Injury to personnel or reducer failure may be caused by improper installation, maintenance or operation.

**WARNING:**

- Written authorization is required to operate or use reducers in man lift or people moving devices.
- Check to make sure that certain applications do not exceed the allowable load capacities published in the current catalog.
- Buyer shall be solely responsible for determining the adequacy of the product for any and all uses to which Buyer shall apply the product. The application by Buyer shall not be subject to any implied warranty of fitness for a particular purpose.
- For safety, Buyer or User should provide protective guards over all shaft extensions and any moving apparatus mounted thereon. The User is responsible for checking all applicable safety codes in his area and providing suitable guards. Failure to do so may result in bodily injury and/or damage to equipment.
- Gearboxes operating in high position should have a protective shield for any possible parts falling down for casual accidents where people are moving under them.
- Hot oil and reducers can cause severe burns. Use extreme care when removing lubrication plugs and vents.
- Make certain that the power supply is disconnected before attempting to service or remove any components. Lock out the power supply and tag it to prevent unexpected application power.
- Reducers are not to be considered fail safe or self-locking devices. If these features are required, a properly sized, independent holding device should be utilized. Reducers should not be used as a brake.
- Any brakes that are used in conjunction with a reducer must be sized or positioned in such a way so as to not subject the reducer to loads beyond the catalog rating.
- Lifting supports including eyebolts are to be used for vertically lifting the gearbox only and not other associated attachments or motors.
- Use of an oil with an EP additive on units with backstops may prevent proper operation of the backstop. Injury to personnel, damage to the reducer or other equipment may result.
- Overhung loads subject shaft bearings and shafts to stress which may cause premature bearing failure and or shaft breakage from bending fatigue, if not sized properly.

**SELLING CONDITIONS**

Warranty for manufacturing defects will expire one-year the invoicing date. Hydro-Mec will replace or repair defective parts but will not accept any further changes for direct or indirect damages of any kind. The warranty will become null and void if repairs or changes are carried out without our prior written authorization.

**Our company will not be responsible for any direct or indirect damages, caused by a wrong use of the products or for not observing the catalogue/web indication**

**Leggere attentamente**

Le seguenti raccomandazioni sono fondamentali per la vostra protezione e per garantirvi molti anni di sicuro funzionamento del vostro prodotto senza alcun problema.

Leggere attentamente tutte le istruzioni prima di azionare il riduttore. L'inappropriata installazione, manutenzione o funzionamento del riduttore può causare incidenti al personale addetto e danni al riduttore stesso.

**ATTENZIONE:**

- E' richiesta autorizzazione scritta per azionare riduttori in ascensori o dispositivi per il movimento delle persone.
- Controllare che alcune applicazioni non eccedano la massima capacità di carico ammessa pubblicata in questo catalogo.
- L'acquirente è l'unico responsabile per la determinazione dell'adeguatezza del prodotto per qualcuna o tutte le utilizzazioni che l'acquirente stesso farà del riduttore. L'applicazione dell'acquirente non potrà essere soggetta ad alcuna implicita garanzia di montaggio per uno scopo particolare.
- Per ragioni di sicurezza l'acquirente dovrà provvedere a porre protezioni adeguate su tutta la lunghezza dell'albero a tutti gli organi in movimento. L'utilizzatore è responsabile del controllo di tutti i codici di sicurezza e la predisposizione di protezioni adeguate. In assenza di tali precauzioni si possono verificare incidenti alle persone e danni agli apparati.
- Su riduttori installati in posizioni elevate utilizzare protezioni adeguate per qualsiasi distacco accidentale di parti nel caso di passaggio di persone al di sotto.
- Olio e riduttori bollenti possono causare gravi ustioni. Usare estrema cautela nella rimozione dei tappi e delle ventole.
- Assicurarsi che la corrente di alimentazione sia scollegata prima di riparare o rimuovere alcun componente. Chiudere l'alimentazione e contrassegnare tale operazione per evitare accensioni accidentali.
- I riduttori non devono essere considerati esenti da guasti o a bloccaggio automatico. Se sono indispensabili queste caratteristiche, deve essere utilizzato un dispositivo indipendente della dimensione adatta. I riduttori non devono essere utilizzati come freni.
- Qualsiasi freno sia utilizzato insieme al riduttore deve essere della giusta grandezza e posizionato in modo da non causare carichi eccessivi non previsti dai dati forniti nel catalogo.
- I dispositivi di sollevamento come le golfare devono essere usati solo per sollevare verticalmente il riduttore e non altri dispositivi associati o motori.
- L'utilizzo di un olio con un additivo EP su gruppi provvisti di dispositivo di arresto possono inficiare l'uso corretto del freno e provocare danni alle persone, alle cose ed al riduttore stesso nonché ad altri apparecchi.
- I Carichi sospesi assoggettano i cuscinetti della vite e la vite stessa a sollecitazioni che possono causare, se non adeguatamente dimensionati, l'usura prematura dei cuscinetti e/o la rottura della vite a causa della resistenza alla flessione.

**CONDIZIONI DI VENDITA**

La garanzia relativa a difetti di costruzione ha la durata di un anno dalla data di fatturazione della merce. Tale garanzia comporta per Hydro-mec l'onere della sostituzione o riparazione delle parti difettose ma non ammette ulteriori addebiti per eventuali danni diretti o indiretti di qualsiasi natura.

La garanzia decade nel caso in cui siano state eseguite riparazioni o apportate modifiche senza nostro consenso scritto.

**La nostra ditta non si ritiene responsabile per eventuali danni diretti o indiretti derivanti da un uso improprio dei prodotti e dalla mancata osservanza delle indicazioni riportate a catalogo o web..**

# New options available

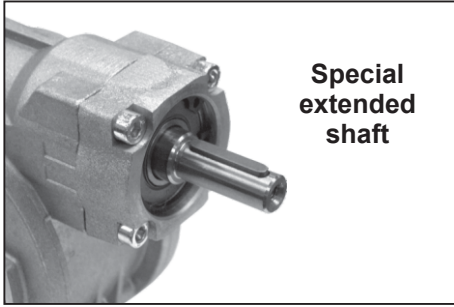

Special extended shaft

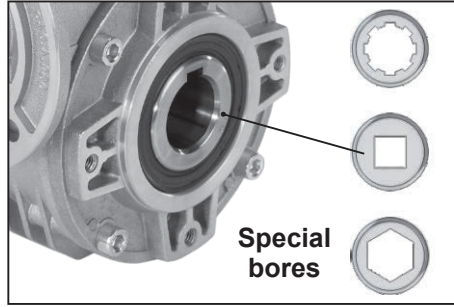

Special bores

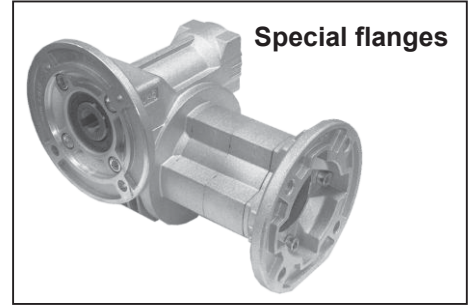

Special flanges

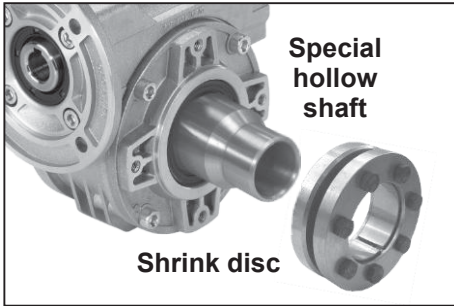

Special hollow shaft

Shrink disc

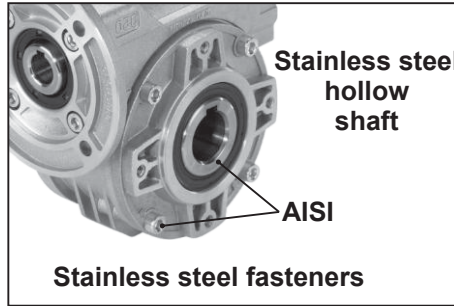

Stainless steel hollow shaft

AISI

Stainless steel fasteners

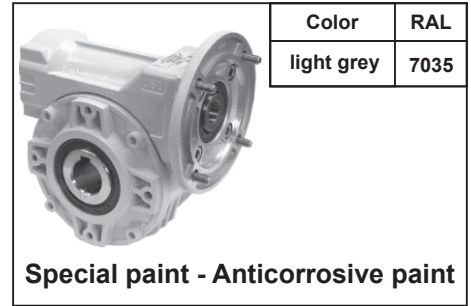

Color	RAL
light grey	7035

Special paint - Anticorrosive paint

## Others HYDRO-MEC products

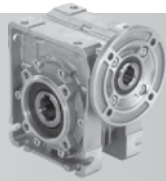

Square worm gearboxes  
Rid. a vite senza fine quadro



Stainless steel worm gearboxes  
Rid. a vite senza fine Inox

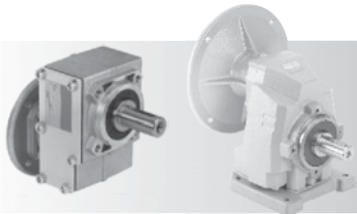

One step gearboxes  
Riduttori ad uno stadio

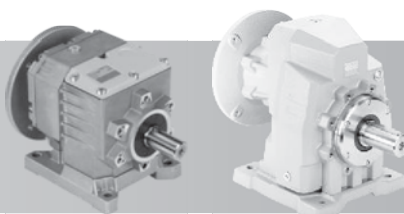

Coaxial gearboxes  
Riduttori coassiali

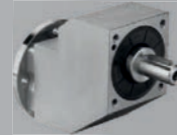

Stainless steel one step gearbox  
Riduttore uno stadio Inox

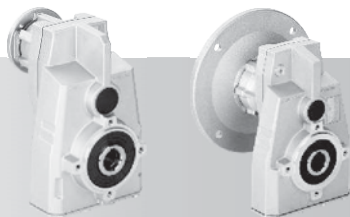

Shaft mounted gearboxes  
Riduttori pendolari

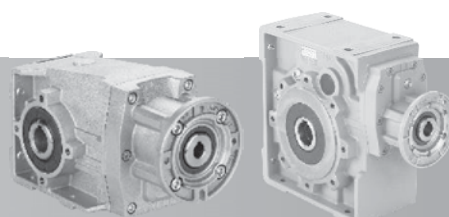

Helical bevel gearboxes  
Rid. a coppia conica

## Distributed From:

### HYDRO-MEC

Via della tecnica, 19  
36050 SOVIZZO (VI) ITALY  
Tel.: +39 0444 551911  
Fax: +39 0444 536139  
e-mail: [hydromec@hydromec.com](mailto:hydromec@hydromec.com)  
Website: [www.hydromec.com](http://www.hydromec.com)

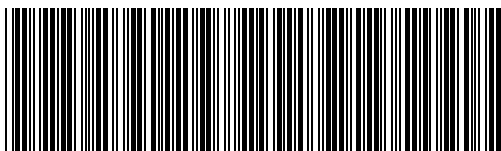

\* CT - VF M- BS - HM0 1 5